

TYPE  
TYPE  
TYPE

765  
766  
767

S  
E  
R  
I  
E  
S

OSCILLOSCOPE  
MANUAL

Serial No. \_\_\_\_\_

**FAIRCHILD**

INSTRUMENTATION  
50 Somerset Place, Clifton, New Jersey, U.S.A.

Portascope Model		Bench Model		Rack Model	
Type	Code	Type	Code	Type	Code
765	26	766	28	767	30
765H	27	766H	30	767H	31
765H/F	27	766H/F	30	767H/F	31
765M	26	766M	28	767M	30
765MH	27	766MH	30	767MH	31
765MH/F	27	766MH/F	30	767MH/F	31



1-3. PHOTOGRAPHS OF BENCH, RACK AND PORTABLE MODELS

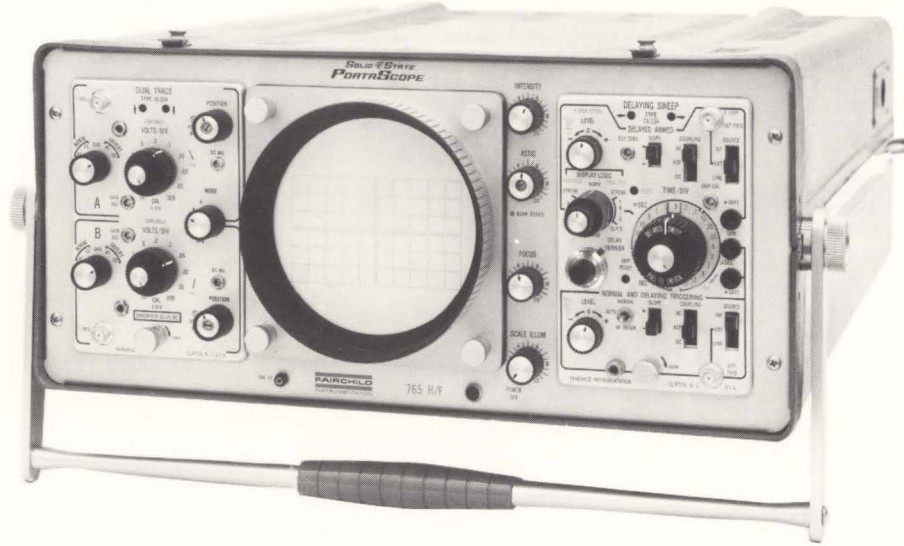

FIGURE 1-1. TYPE 765 PORTASCOPE

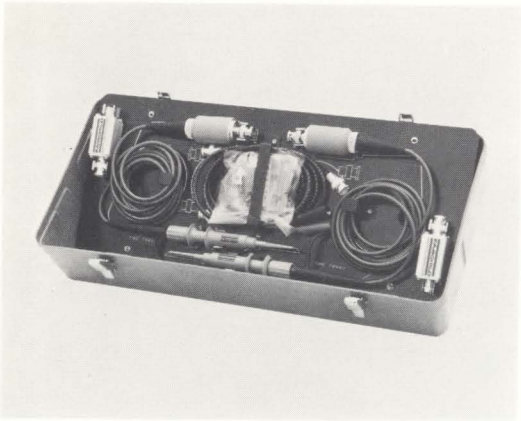

FIGURE 1-2. TYPE 765 COVER WITH ACCESSORY PANEL



FIGURE 1-3. TYPE 766 BENCH MODEL

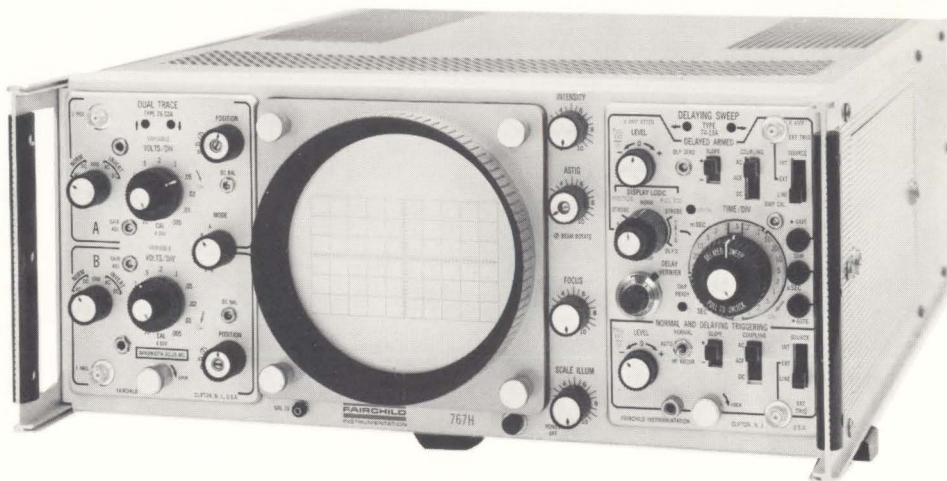

FIGURE 1-4. TYPE 767 RACK MODEL

# SECTION 1

## TECHNICAL SUMMARY

### 1.1 INTRODUCTION (Figures 1-1 to 1-4)

The Fairchild Types 765, 766, and 767 Family of Oscilloscopes are available in three basic form factors: bench, rack, and portable models. The Portable Models are identified by the Type 765 numerical Series; the Bench Models by the Type 766 numerical Series, and the Rack-mounted Models by the Type 767 numerical Series.

In addition, there are alphabetical suffixes appended to the numerical series to identify special electronic circuits. The suffix H denotes the high-voltage oscilloscope with an accelerating potential of 13 Kv. The low voltage option is 5 Kv and these series oscilloscopes are identified by the absence of the H alphabetical suffix.

The suffix H/F denotes the high-voltage, high-frequency model. These models are provided with the Type 7062 CRT Termination Network to enable them to accommodate the Type 79-02A DC to 100 Mc Plug-in Amplifier. The suffix M denotes the militarized model. Further details for all of the models are listed in the Specifications.

Since the electrical circuits are identical in all models except for minor differences, discussion will be confined to the Type 766H Series Oscilloscope. All references to the Type 766H Series will be equally applicable to the other models unless otherwise indicated.

To simplify discussion, the Type 766H Series Oscilloscope may be categorized into three basic Series: (1) Low-voltage, (2) High-voltage, and (3) High Frequency.

1. The following models comprise the low-voltage Series:

Type 765, 765M, 766, 766M, 767, and 767M

2. The following models comprise the high-voltage Series:

Type 765H, 765MH, 766H, 766MH, 767H, 767MH

3. The following models comprise the high-frequency Series:\*

Type 765H/F, 765MH/F, 766H/F, 766MH/F, 767H/F, & 767MH/F

\**Note:* These oscilloscopes are electrically identical to the high-voltage series except for the addition of the high-frequency CRT Termination Network.

Separate manuals are provided for each of the plug-in units. If desired, these manuals may be inserted into the same binder supplied with your Indicator unit.

### 1-2. FEATURES

The Fairchild Family of Oscilloscopes consists of an Indicator Unit and any two of a number of available plug-in modules. The Indicator Unit contains the power supplies, a cathode-ray tube with associated circuitry, and an internal amplitude calibrator.

The plug-in modules take the place of the vertical and horizontal deflection systems of a conventional oscilloscope, and their outputs are connected directly to the deflection plates of the cathode-ray tube.

All plug-ins in the Type 74-00 and 76-00 Series may be used universally in the oscilloscope. The plug-in modules may be selected to give a degree and type of performance demanded of them by the particular application for which they are to be used.

- 13 Kv accelerating potential (low-voltage option: 5 Kv)
- Quality display area of 6 cm by 10 cm
- Three basic Main Frames available: Portable (Type 765-), Bench (Type 766-) and Rack-mounted (Type 767-)
- Silicon solid state circuitry
- Dual Plug-in capability (DC to 100 Mc) with all High Frequency or H/F Models
- Z-axis input provided on all bench and rack-mounted models
- Illuminated internal graticule optionally available
- Silicon transistors and fully regulated electronic power supplies, assure maximum drift stability and long-term reliability

# section 1 — technical summary

## 1-3. LIST OF RECOMMENDED ACCESSORIES

Type or Part Number	Description
<b>ATTENUATOR PROBES</b>	
(10:1 terminated in BNC type connector)	
	4289B
4289B, MOD 101	4290B 10M, 10pf; 4-ft cable
4289B, MOD 102	4298B 10M, 14 pf; 8-ft cable
	4292B 4299B 10M, 12 pf; 6-ft cable
4309B	7994B* 10M, 7 pf; 4-ft cable
	7999B* 10M, 9 pf; 9-ft cable

\* For use with Type 79-02A Dual Trace DC to 100 Mc Amplifier.

### COLOR FILTERS

4800 5861	Amber for P7 screen
4800 5862	Blue for P11 or P7 screen
4800 5863	Green for P2 and P31 screen
4800 6101	Neutral, circularly polarized
4501 0452	Anti-parallax scale

### SCOPE TRAVELERS & RACK SLIDE

7020	Top Tray: 10 3/4 inches x 22 1/2 inches; 26 1/2 inches from floor
7030	Top Tray: 17 3/4 inches x 22 1/2 inches; 32 1/2 inches from floor
7085A	Slide drawer (for rack-mounted unit) See Figs. 1-6 to 1-8.

### TERMINAL ADAPTERS

7084	Male BNC type connector to Type C female adapter, UG-635/U
7080	Scope binding post to BNC adapter

### VIEWING ACCESSORIES

276C	Viewing Hood made of molded rubber
7035	Round light shield to reduce glare and reflection; does not have a molded eye-piece

### TERMINATING RESISTOR

4285A	50-ohm, 5-watt, Type C connector
-------	----------------------------------

### CAMERAS

450/450A, 453/453A	Oscilloscope-Record Cameras with suitable accessories
-----------------------	---

### CABLE ASSEMBLY

4294	Extension cable for remote operation of the plug-in from the oscilloscope
------	---

### OPERATIONAL ACCESSORY KIT

4296	Complete kit contains:
------	------------------------

Qty	Type	Description
1	276C	Viewing Hood
2	4285A	50-ohm Termination
1	4290	Probe

### OPERATIONAL ACCESSORY KIT (Cont)

Qty	Terminal Adapters	
	Type	Description
2	4287	Right angle; UG-306A/U
2	UG-636/U	C male to BNC female
2	UG-1090/U	BNC to plug tip (banana)

### CRT TERMINATION NETWORK

7062	CRT Termination Network Kit to transform the H models to H/F models. This network is standard equipment with the High-Frequency Main Frame Oscilloscopes (Types 765H/F, 765MH/F, 766MH/F, 766H/F, 767H/F and 767MH/F)
------	---

## 1-4. TECHNICAL SUMMARY (Specifications)

The electrical and physical characteristics of the Types 765, 766 and 767 Series Oscilloscopes are listed in the following Performance Specification. The technical characteristics of the Type 765 MH militarized version of the Type 765, are listed under a separate paragraph.

### CATHODE-RAY TUBE DATA

#### Type

#### Low-Voltage Series

(765, 765M, 766, 766M, 767 & 767M)

F7650-0-P31 single beam, electrostatic focus and deflection cathode-ray tube is normally supplied; 5000 volts accelerating potential

#### High-Voltage Series

(765H, 765MH, 766H, 766MH, 767H & 767MH)

F7660-0-P31 single beam, electrostatic focus and deflection cathode-ray tube is normally supplied; 13,000 volts accelerating potential

#### High-Frequency Series

765H/F, 765MH/F, 766H/F, 766MH/F, 767H/F, & 767MH/F)

F7670-0-P31 single beam, electrostatic focus and deflection cathode-ray tube is normally supplied; 13,000 volts accelerating potential

#### Optional Phosphors

P7 phosphor for long persistence low frequency or transient observation; P11 phosphor for photographic use; and P2 phosphor for combination visual and photographic use. All other phosphors available on special order

#### Aluminization

All tubes are aluminized for maximum light output and to prevent screen charge distortions

#### Bezel

Light-tight bezel provides firm mount for an oscilloscope camera and permits ready interchange of filters and scales

## SPECIFICATIONS

### Graticule

Engraved edge-lit graticule having 6 cm by 10 cm graduations and appropriate color filter over face of tube. Scale illumination control varies light level from zero to intensity adequate for photographic recording. CRT internal no-parallax graticule is optionally available; white scale may be edge lit for photographic recording

### CRT Direct Input

1. X Axis: 10 to 15 volts/cm (all CRT series)
- 2a. Y Axis: 5.2 to 7.2 volts/cm (F7650-0-P- and F7660-0-P- CRT only)
- 2b. Y Axis: 2½ to 3½ volts/cm (F7670-0-P- CRT only)

### Z Axis (Bench and Rack-mounted Models only)

Negative pulse to grid of CRT blanks trace. 25 volts are required into an impedance of approximately 1 megohm coupled via 0.01  $\mu$ f capacitor to dim trace

### CRT Beam Controls

INTENSITY, FOCUS, and ASTIG controls are provided on the Main Frame for controlling the CRT beam

### Beam Brightening

A switch labeled NORMAL/SINGLE is provided on the Type 766 High-Voltage and High-Frequency Series chassis. Beam brightening can be accomplished by beam gating (normal operation) or by cathode gating (for photographing single-shot high-speed transients)

## VOLTAGE CALIBRATOR

### Amplitude

Cal 1V, peak-to-peak square wave signal available at pin jack on front panel of Main Frame ( $\pm 2.5\%$  maximum,  $\pm 1\%$  nominal); fast rise and fall time permits adjustment of attenuator probe

### Accuracy

Nominally  $\pm 1\%$ , always within  $\pm 2.5\%$

### Frequency

Locked to power-line frequency. This waveform may be used to calibrate the time axis wherever the power-line frequency is controlled standard

### Access to Plug-Ins

The same 1-volt calibrator waveform is supplied to each plug-in. The amplifier plug-ins will be provided with a suitable arrangement for calibration of

all active circuitry. The calibrator waveform will normally be inserted into the input stage by means of the VOLTS/DIV switch

## POWER REQUIREMENTS

### Line Voltage

From 105 to 125 volts or from 210 to 250 volts at 60-cycle line

### Line Frequency

Operation from 48 through 1000 cycles; line voltage excursion is reduced at extremes of frequency range and where power line distortion exceeds 5%

### Power

From 150 to 230 watts depending on the plug-in used

### DC Power Supplies

All supplies are electronically regulated

## ENVIRONMENTAL SPECIFICATIONS\*

### Operating Temperature Range

From 0°C to 50°C. All models incorporate a thermal cutout switch to protect the unit when cooling is insufficient. Adequate ventilation and clearance around unit must be provided in rack-mounted installation to assure intake air below the specified ambient temperature

### Storage Temperature Range

From -40°C to +85°C

### Altitude Range

Sea level to 15,000 feet

### Humidity

Constant operation at 30°C and 80% relative humidity. Intermittent operation under all humidity and temperature specifications that prevent condensation

### Shock

10G shock for duration of 25 milliseconds

### Vibration

15-minute cycle from 10 to 33 cycles at 0.015 inches double amplitude; vibrates in 3 planes

\* Applicable for all models except militarized or "M" Models.

Data for "M" models is given elsewhere in this Specification.

## section 1 – technical summary

### PHYSICAL CHARACTERISTICS

	<i>Portable Models</i>	<i>Bench Models</i>	<i>Rack-Mounted Models</i>
	765-	766-	767-
Height	8 $\frac{1}{4}$ "	13 $\frac{3}{4}$ "	7"
Width	17 $\frac{3}{4}$ "	9 $\frac{3}{4}$ "	19"
Depth	23"	20 $\frac{5}{8}$ "	20"*
Weight	18 lbs	27 lbs	27 lbs
Carrying Case	9 lbs	—	—
Shipping Weight	37 lbs	37 lbs	37 lbs

Note: A minimum of 2" clearance must be maintained for the rack-mounted model to assure adequate cooling. Do not subject the unit to the hot exhaust air of adjacent equipment.

\* Behind panel. With mounting brackets reversed: 18 $\frac{3}{4}$  inches

### TYPE 7085 RACK INSTALLATION

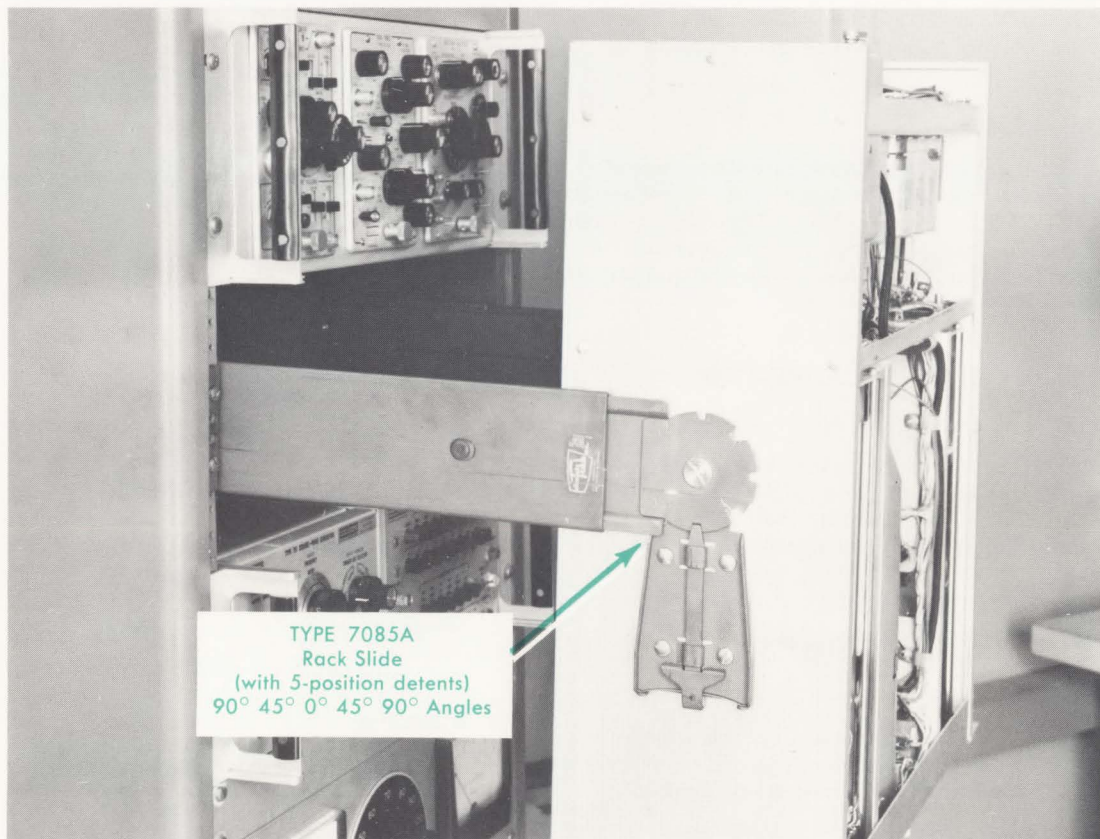

Figure 1-5. Type 7085A Rack Slide Set to 90° with Type 767H Oscilloscope Installed



# technical summary – section 1

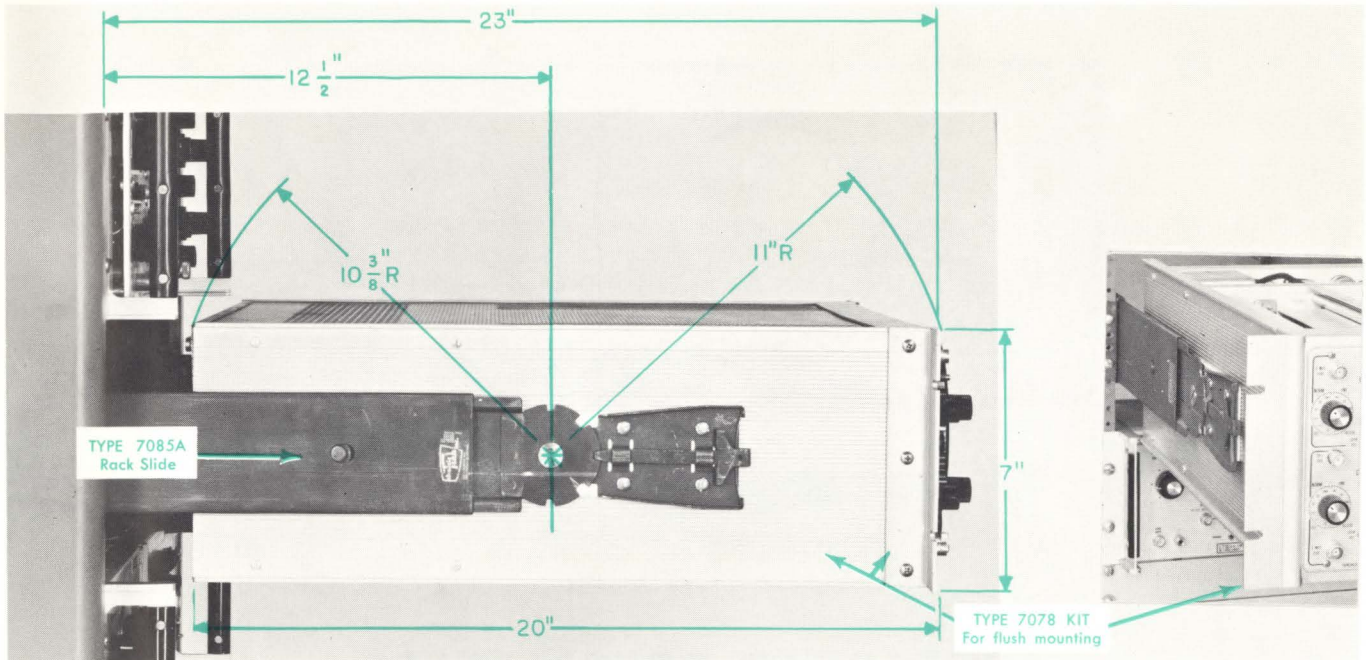

Figure 1-6. Type 767H Oscilloscope Showing Clearance Dimension for Installation of Type 7085A Rack Slides and Type 7078 Kit for Flush Mounting

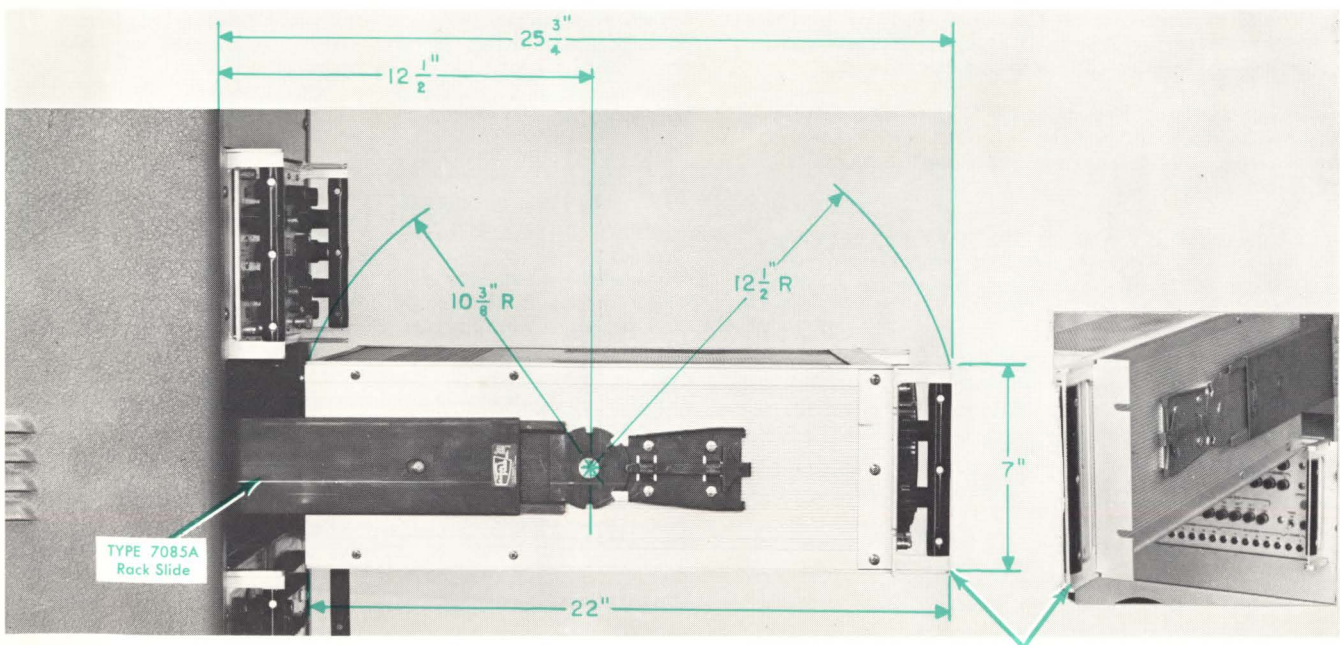

Figure 1-7. Type 767H Oscilloscope Showing Clearance Dimension for Installation of Type 7085A Rack Slides (Standard Installation)

## section 1 — technical summary

### 1-5. TYPE 765MH TECHNICAL DATA



Figure 1-8. Type 765MH

## MILITARIZED PORTASCOPE®

- Meets ruggedized military specifications
- Operation from line power frequencies of 48-1000 cycles
- Low power consumption
- Operation from  $-30^{\circ}$  to  $+60^{\circ}\text{C}$
- Semiconductor circuitry
- Light weight — extremely portable
- RFI shielding
- Federal Stock Number 6625-056-7115
- Each unit is vibration tested
- Certification of compliance supplied with each system

The 765MH is a militarized, rugged, portable oscilloscope. The unit is housed in a sturdy fiberglass case. A convenient carrying handle permits easy transport through narrow aisles, hatchways or any confined area. A fiberglass cover is provided with facilities for mounting accessories.

This basic indicator houses the CRT, power supplies, and has two cavities into which various X and Y plug-ins may be inserted. All electrical specifications are identical to the 765H Series.

**Heater Strips** — A 200-watt thermostatically controlled standby heater is incorporated for low temperature operation. 200 watts of additional standby power are required below  $0^{\circ}\text{C}$ .

**Weight** — The weight of this unit including plug-ins is less than 35 pounds. Main frame weight is under 27 pounds. Case and covers are constructed of rugged fiberglass material. An RFI metallic coating is sprayed inside the case.

#### Temperature Range (in all positions) —

Storage  $-40^{\circ}\text{C}$  to  $+85^{\circ}\text{C}$   
 Operating  $-30^{\circ}\text{C}$  to  $+50^{\circ}\text{C}$  (without fan)  
 $-30^{\circ}\text{C}$  to  $+60^{\circ}\text{C}$  (with fan)  
 (modification 103)

#### Operational Altitude —

Operational to 15,000 feet  
 Non-operating to 50,000 feet

**Humidity** — Constant operation at  $40^{\circ}\text{C}$  and 95% relative humidity. Intermittent operation under all humidity temperature specifications which prevents condensation. Meets MIL standard 202B method 106A except freezing. No condensation permitted when operating.

#### Shock —

20 G shock for duration of 5 ms  
 15 G shock for duration of 11 ms  
 10 G shock for duration of 25 ms  
 (4 shocks in each plane for a total of 12 shocks.)

**Vibration** — 15-minute cycle from 10 to 3000 cycles at 0.010 inches double amplitude (peak-to-peak). Vibrated in 3 planes, 15-minutes in each plane (**2 G limit**) with a 5-minute scan cycle. 15-minute cycle from 10 to 3000 cycles at 0.025 inches double amplitude (peak-to-peak). Vibrated in 3 planes, 15-minutes in each plane (**5 G limit**) with a 30-second scan cycle. Four web guides are provided for mounting the fiberglass case.

**Transit** — Unit will meet National Safe Transit Specifications when factory packaged. Vibration for one hour at 1.2 G 30-inch drops on corners, edges and flat surfaces.

**Height** —  $8\frac{1}{4}''$  20.9 cm

**Width** —  $17\frac{3}{4}''$  45.0 cm

**Depth** — (with cover)  $23''$  58.4 cm

**Weight** —  
 Net — 27 pounds Shipping — 37 pounds

# SECTION 2

## OPERATING INSTRUCTIONS

### 2-1. INTRODUCTION

This section of the Instruction Manual describes the operation of the Indicator Unit with the Plug-in modules inserted. Operation of the Indicator Unit with the plug-in modules inserted is the same as that of a conventional oscilloscope with corresponding vertical and horizontal deflection systems. Full operating instructions for each of the plug-in modules are contained in the manual which accompanies it.

### 2-2. PRELIMINARY INFORMATION

The Type 766H/F Oscilloscope is a general purpose, wide band laboratory instrument with dc to 100 Mc capabilities. The dual cavities of the instrument will accept any of the present Types 74-00, 76-00, and 79-00 Series Plug-ins, thus determining the oscilloscope's ultimate performance. The Type 766H/F Oscilloscope is in essence a Type 766H Series unit which has been provided with the Type 7062 CRT Termination Network to accommodate the Type 79-02A 100 Mc Dual Trace Amplifier Plug-in. For the militarized or "M" models, a 200-watt thermostatically-controlled standby heater is incorporated for low temperature operation.

The low-voltage power supply provides regulated and unregulated voltages for application throughout the instrument. The cathode-ray tube circuitry provides the necessary controls and adjustments for presenting a sharp display of the desired intensity for displaying the signals applied to the deflection plates by the plug-in modules.

The voltage calibrator yields a 1-volt, peak-to-peak fast rise and fall time square wave signal for use in normalizing the gain of the plug-in amplifier modules and for setting the timing of the time base plug-in module wherever the power-line frequency is a controlled standard.

### 2-3. POWER REQUIREMENTS

The line transformer in this oscilloscope can be set for either 115-volt or 230-volt operation; a plate on the rear of the instrument specifies the voltage for which your instrument is set. If the instrument is set for 115-volt operation, it will operate properly at any line voltage between 105 and 125 volts. If it is set for 230-volt operation, it will operate properly at any line voltage between 210 and 250 volts. Line voltages beyond the limit specified may cause the power supplies

to go out of regulation. Power-line voltage excursion will be more limited over the permissible power-line frequency range of 48 to 1000 cycles. Harmonic distortion should not exceed 5%.

If desired, this instrument can be converted from 115-volt operation to 230-volt operation, or vice versa, by merely setting the 115V/230V Selector switch to the desired voltage.

Although primarily designed to operate at a line frequency between 50 and 60 cycles, this instrument can be operated at any line frequency from 48 cycles to 1000 cycles. However, slightly higher line voltages are required at the higher frequencies.

### 2-4. OPERATING INSTRUCTIONS (Figures 2-1 and 2-2)

Any of the plug-in modules may be inserted in either of the cavities in the front of the instrument. The module on the right, controls the horizontal deflection of the beam, and the module on the left, controls the vertical deflection of the beam. Thus, it is possible to change from a horizontal time sweep to a vertical time sweep merely by changing the position of a time-base module. However, there is no provision for coupling an unblanking pulse from the left-hand module to the cathode-ray tube, so when a vertical sweep is used, the trace is not blanked between sweeps. X-Y operation is obtained by using amplifier modules in both oscilloscope cavities. (The right-hand cavity is often referred to in the plug-in manuals as the "X-Axis" cavity; the left-hand cavity is referred to as the "Y-Axis" cavity.) The procedure for making the adjustment on each plug-in is described in its individual manual.

The following illustrations are designed to aid the operator in becoming familiar with the oscilloscope.

Figure 2-1. Type 766H Solid State Oscilloscope, Front-Panel Facilities

Figure 2-2. Type 766H Calibrator Display

We know that you are anxious to get acquainted with your new instrument. To aid you in this endeavor, you may set up the instrument using the built-in calibrator signal to demonstrate the effects of the various controls on the display.

Intensity modulation of the CRT beam is possible through the Z INPUT connector at the rear of the oscilloscope.

## section 2 – operating instructions

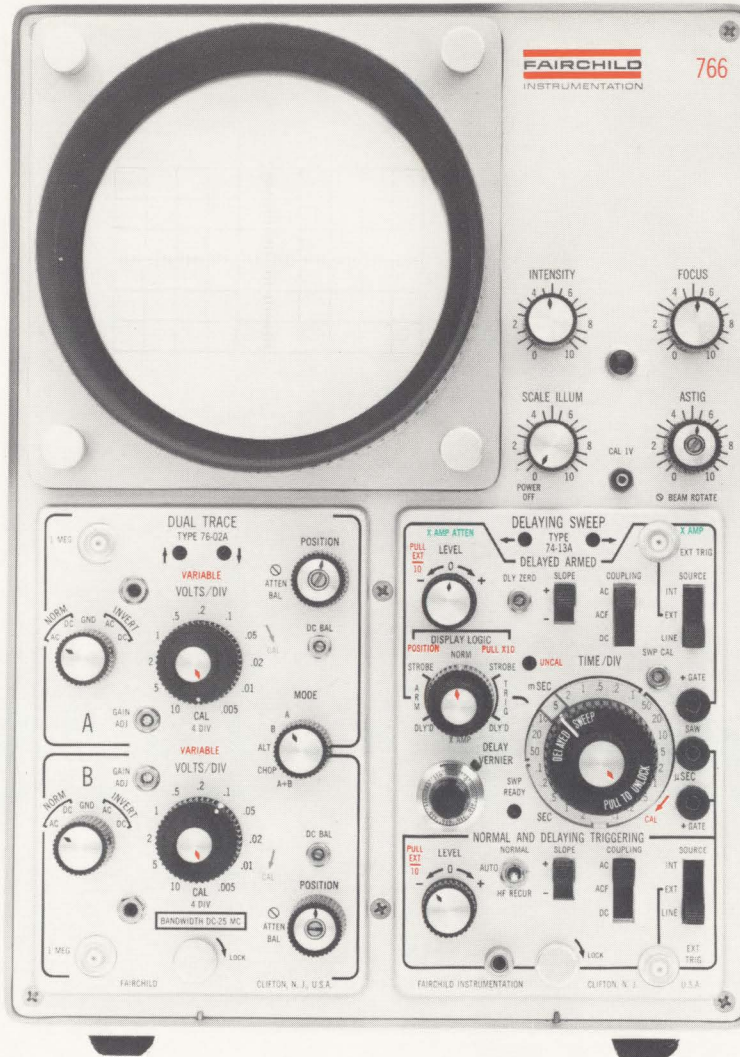

### INTENSITY

Control: varies trace brightness

### SCALE ILLUM

Control with switch: dimmer control varies scale illumination; attached switch turns power on or off

### FOCUS

Control: provides an adjustable voltage for cathode-ray tube focus grid to optimize spot size

### ASTIG

Control: provides an adjustable voltage for cathode-ray tube to optimize spot shape

### BEAM ROTATE

Concentric screwdriver control: varies the field strength which the CRT beam intercepts causing it to rotate, thus compensating for the earth's magnetic effect on trace alignment

Figure 2-1. Type 766 Solid State Oscilloscope, Front Panel Facilities

# operating instructions – section 2

To obtain the calibrator display, set the controls exactly as shown and perform the numbered steps in sequence.

Use the same procedure when difficulty is experienced when obtaining a display. This will eliminate "cockpit" troubles due to misalignment of controls.

**1** Rotate clockwise to turn on the oscilloscope

**2** Set both TIME/DIV "clutched knobs" to 5 mSEC

**3** Set VERNIER fully clockwise

**4** Set switches to: +, AC, & LINE

**5** Set to AUTO

**6** Set POSITION controls to center of range

**7** Set to NORM AC

**8** Set outer knob (VOLTS/DIV) to CAL

**9** Rotate inner knob (VARIABLE) fully clockwise

**10** Set to MODE A

Set outer knob (MODE) to CH 1

Readjust INTENSITY, FOCUS and ASTIG controls for a sharp pattern. Readjust 6 to center the display

Set ASTIG, FOCUS, & INTENSITY controls to center of range

Figure 2-2. Type 766 Calibrator Display

## section 2 – operating instructions

To remove a plug-in from the Main Frame, simply unscrew the knurled thumbscrew at center bottom of unit and pull it free of the Main Frame. The plug-in unit is provided with a power-line interlock jumper on its connector, hence all power is automatically disconnected whenever a plug-in is removed.

When you change a module from one cavity of the Indicator Unit to the other, you must adjust the gain of the plug-in unit to allow for the difference in vertical and horizontal sensitivity of the cathode-ray tube. This is accomplished by means of the GAIN ADJ or SWP CAL front-panel screwdriver controls on the plug-in modules and permits normalization of the plug-ins to any Main Frame.

The Type 76-00 Series plug-ins have a GAIN CAL range in the order of 3 to 1 so that in general they can be calibrated to the scale markings in either the Y or X cavity.

All Type 74-00 Series Amplifier plug-ins can be calibrated to the scale markings in either the Y or X cavity.

The Type 74-00 Series Sweep plug-ins have a calibration range of approximately  $\pm 25\%$  to adjust for variations in X sensitivity of individual Main Frames. When inserted in the Y cavity, these plug-ins can only be calibrated to twice their normal sweep rate.

### 2-5. BEAM BRIGHTENING FACILITY (Figure 2-3)

A back-of-panel slide switch labeled BEAM BRIGHTENING is provided on all of the high-voltage and the high-frequency Main Frame models so that both NORMAL (beam gate blanking) and FAST SINGLE SWEEP ONLY (grid-cathode blanking) are available. See Figure 5-6 for location of switch.

Beam brightening is normally accomplished by applying the unblanking pulse to the CRT beam gating

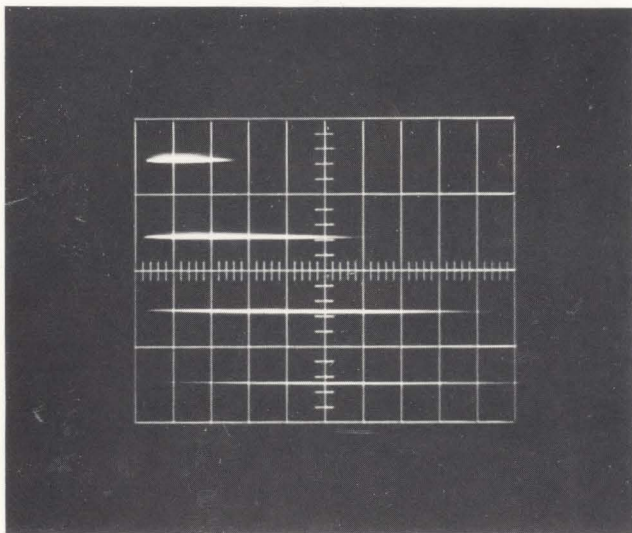

Figure 2-3. Single Sweep Unblanking vs Sweep Speed

plates. To record high-speed transients, it is necessary to unblank or brighten the CRT beam with an AC coupled negative gate applied to the cathode of the CRT. Cathode drive for beam brightening is desirable when high writing rates are required to assure maximum beam current with minimum spot size.

Basically, the beam brightening feature should not be used except on fast sweeps, because in the single shot mode, the brightening gate is ac coupled to the cathode of the CRT. This means that if slow sweep speeds are used, full scan unblanking may not be available since the brightening gate will be differentiated by the capacitive-resistive coupling network.

Figure 2-3 shows the effect of the AC coupled beam brightening pulse. The Time Base unit was set up for single sweep and for sweep rates of 50  $\mu\text{sec}$ , 20  $\mu\text{sec}$ , 10  $\mu\text{sec}$ , and 5  $\mu\text{sec}$  respectively. Judging from Figure 2-3, it may be seen that the beam brightening is only effective at very fast sweep speeds. This effect offers no real disadvantage since the purpose of the Single Shot mode is to photograph fast transients. By setting the BEAM BRIGHTENING switch to NORMAL, the unit may be operated as a standard oscilloscope.

### 2-6. OPERATOR'S MAINTENANCE INFORMATION

Frequently, many oscilloscope ailments may be discovered through an erroneous display on the screen or by the conspicuous absence of a display. The information in the paragraphs to follow will pin-point this information according to the symptoms presented to the operator.

#### a. A Naked Screen

If the operator is not able to obtain a trace or spot on the screen for either beam after substituting other plug-ins known to be operating properly, the trouble is confined to the Indicator or Main Frame Unit. Refer to Section 5 of this manual for diagnostic and remedial procedures.

#### b. Insufficient Deflection

If the horizontal or vertical deflection signal cannot be set to the proper value with the front-panel screwdriver controls GAIN ADJ or SWP CAL on the plug-ins, then check the output of the low-voltage regulated supplies at Test Points TP1001, TP1101, TP1201, and TP1301 located on the Main Frame. The high-voltage Test Point is TP2001 also located on the Main Frame chassis. If these voltages check out alright, the trouble may reside in one of the plug-ins. If there is insufficient vertical deflection, it is in the left-hand module; if there is insufficient horizontal deflection, it is in the right-hand module. Refer to the appropriate plug-in module Instruction Manual for further information.

### c. Improper Sweep Timing

A front-panel screwdriver control, SWP CAL, is provided on the Time Base Plug-in to permit normalization of this module to any main frame. If this control does not have sufficient range, then check the output of the regulated supplies at the Test Points previously mentioned. If these voltages are normal, then check out the Time Base Plug-in.

### d. Improper Triggering

If external and line triggering modes are satisfactory, but the internal triggering mode is not, then the trouble may reside in the trigger take-off circuit of the

Y Plug-in amplifier that the operator is using. However, if improper triggering cannot be obtained from any of the triggering sources, the trouble probably resides in the Time Base Plug-in itself. Refer to the Time Base Plug-in Instruction Manual for more information.

### e. Waveform Distortion

If the display under observation is distorted, but there is no other manifestation of trouble such as insufficient deflection, improper sweep rate etc., then the problem is confined to the plug-in which is amplifying the distorted signal. Check that the PATTERN POSITIONING control is properly adjusted.

## NOTES



# SECTION 3

## CIRCUIT DESCRIPTION

### 3-1. INTRODUCTION

This section of the Instruction Manual contains the circuit description of the Main Frame or Indicator Unit alone. The circuit description will be keyed to the Functional Block Diagrams, Figures 3-1 and 3-2. Emphasis is placed on the interrelation of circuits rather than on detail of operation. It is also recommended that the schematics at the rear of this manual be referred to in following the circuit description.

### 3-2. CIRCUIT DESCRIPTION FOR LOW VOLTAGE REGULATED SUPPLIES (Figures 3-1 and 3-2)

#### a. Power Transformer

Low voltage and heater power for this instrument is provided by power transformer T1001. The primary is wound with two equal 115-volt windings that can be switched either in parallel for 115-volt operation, or in series for 230-volt operation via the 115V/230V Selector switch S100. The secondaries contain four separate windings which provide power to the regulated supplies and two separate heater windings.

#### b. Regulated Supplies

Four regulated and two unregulated supplies are provided with output as shown in Figures 3-1 and 3-2, Functional Block Diagrams of the Power Supply. All of the regulated supplies are of the constant-output voltage series-passing type.

The basic reference for all of the regulated supplies is established by the fixed drop across zener diode CR1304. This constant drop or reference voltage is applied to the base of Q1302 which is one of the inputs to differential amplifier Q1301 and Q1302. The other input to the amplifier is connected across a divider consisting of R1302 through R1305 which samples a portion of the  $-50V$  regulated output.

A portion of this sample voltage is tapped by the  $-50V$  ADJ potentiometer R1303, and is applied to the base of Q1301. Potentiometer R1303 is adjusted so that the output is precisely  $-50$  volts. The minus 50-volt output is also the voltage reference source for the other low-voltage regulated supplies. Thus, voltage adjustments are always made in the sequence starting with the  $-50$ -volt supply and ending with the  $+200$ -volt supply.

Since the operation of the low-voltage regulated supplies is similar, only the  $+50$ -volt supply is described. CR1201 and CR1202 are connected in a conventional full-wave rectifier circuit. The rectified output is capacitively filtered by C1201 shunted by resistor R1202 and applied to the voltage regulator.

Operation of the regulator is as follows: assume the output voltage tends to decrease. This will lower the base voltage of the error detector dc amplifier Q1201, and raise the base voltage of emitter follower driver Q1202.

The increase in voltage at the emitter of Q1202 is applied to the base of the series-passing transistor Q1203. The resultant increase in voltage at the emitter of the pass transistor is such as to return the output voltage to its proper value.

#### c. Voltage Calibrator

The power-line frequency voltage from T1001 is applied to the base of the voltage calibrator Q1051 through limiting resistor R1051. Negative and positive voltage excursions will drive the transistor into and out of conduction at the line-frequency rate. The resulting square wave is applied to a voltage divider consisting of R1053 and R1054. The attenuated calibrator output of one volt peak-to-peak is coupled to the amplifier plug-in when the VOLTS/DIV switch is set to CAL. The plus 100-volt supply and the saturation voltage of the transistor will determine the peak-to-peak voltage excursion of the calibrator waveform.

### 3-3. CRT CIRCUIT

#### a. CRT Beam Control Circuits

The INTENSITY control R2016, part of the negative high-voltage divider is used to vary the cathode-ray tube grid voltage to adjust the beam current. The FOCUS control R2014 is provided to vary the voltage at the focusing anode to set the second cross-over point right at the screen of the cathode-ray tube. The ASTIGmatism control R2022F is provided to vary the voltage at the astigmatism anodes to focus the spot in both axes simultaneously. The PATTERN CORREction service adjustment is set to vary the field the cathode-ray beam encounters as it emerges from the deflection system to control the linearity at the extremes of deflection.

The BEAM ROTATE front-panel screwdriver control R2022 is provided to vary the current through coil L2001 around the neck of the CRT. The current varies the field strength which the CRT beam intercepts causing it to rotate. This function is used to compensate for the earth's magnetic effect on trace alignment.

#### b. High Voltage Power Supply

Accelerating voltages for the cathode-ray tube are obtained by rectifying a 30-Kc high voltage produced

## section 3 – circuit description

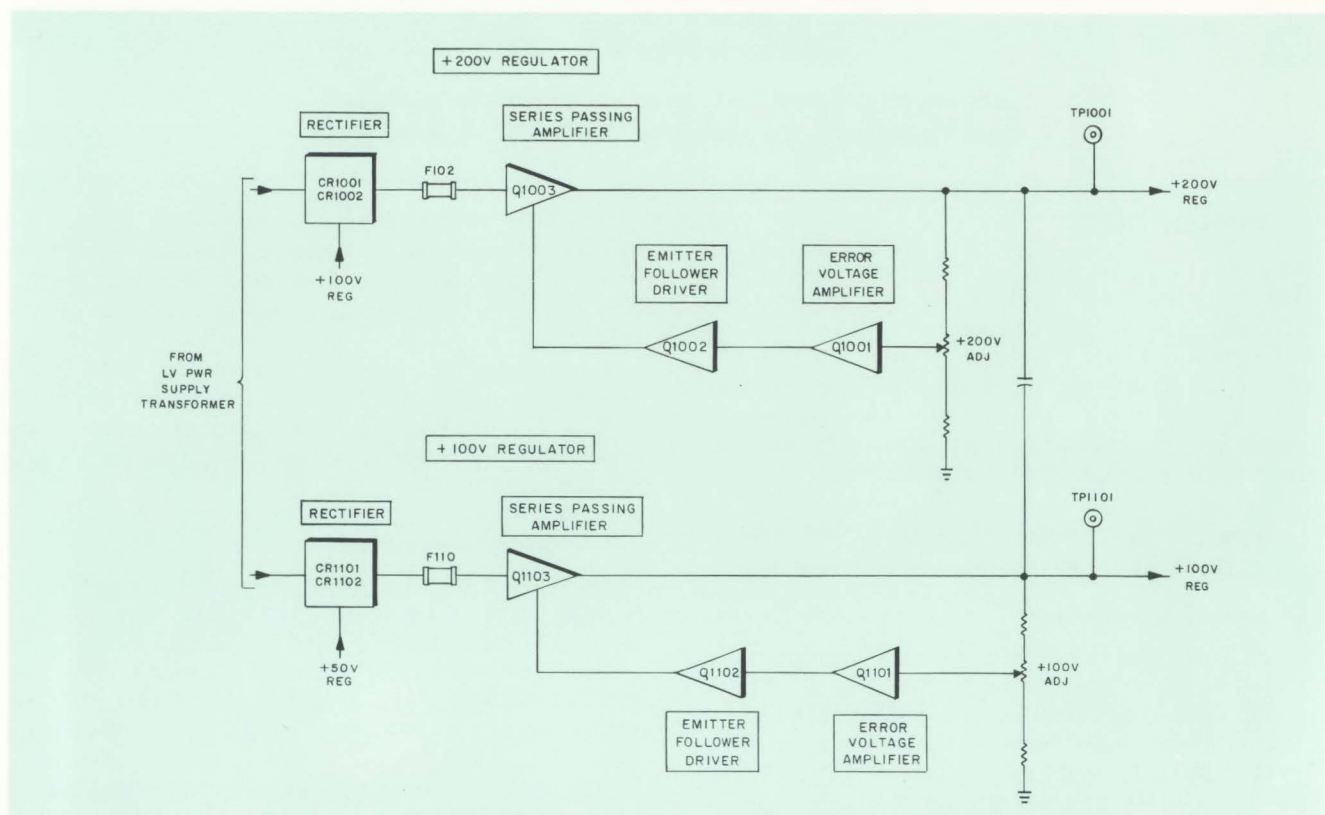

Figure 3-1. +200V and +100V Regulators, Functional Block Diagram

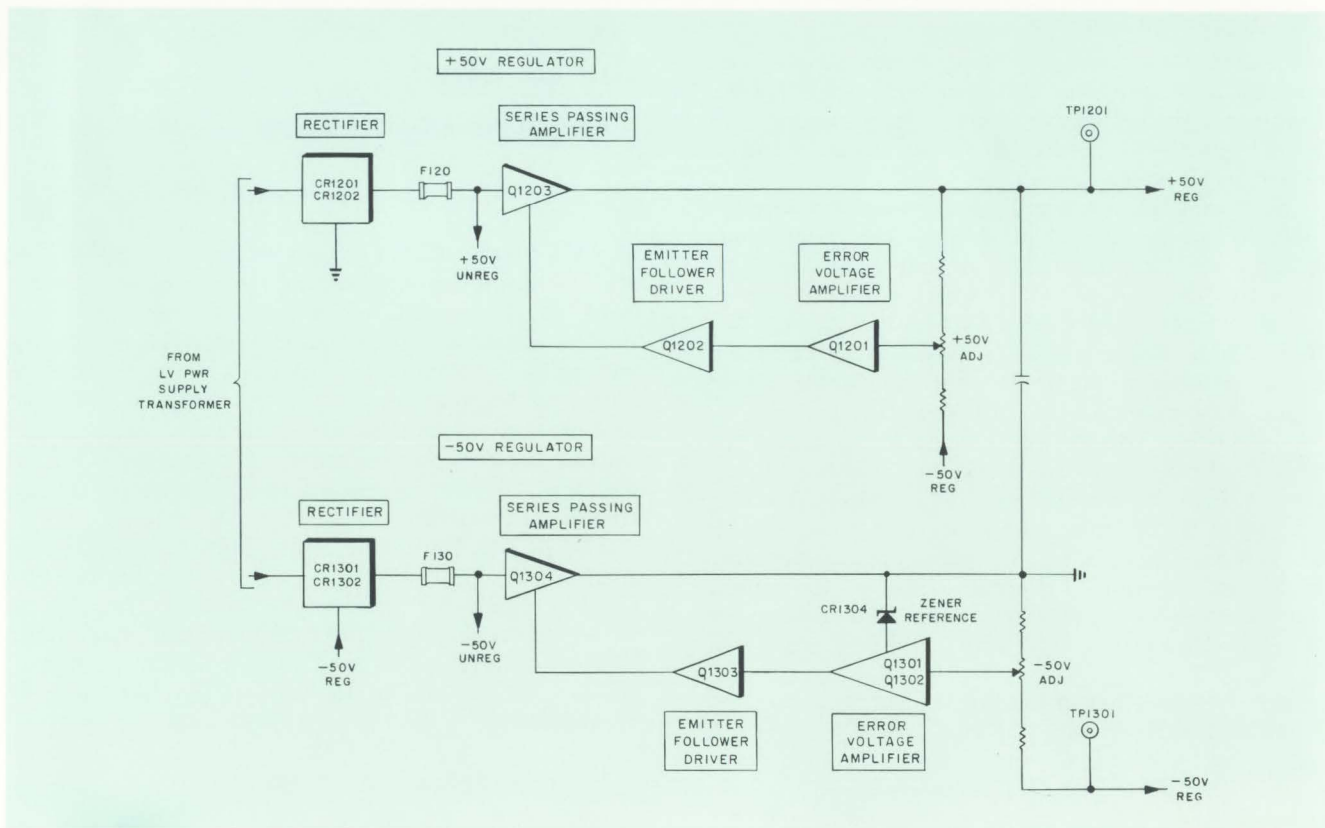

Figure 3-2. +50V and -50V Regulators, Functional Block Diagram

by transistor oscillator Q2002. This transistor is connected as a Class C oscillator with the primary of transformer T2001 tuned by the strayed capacitance and the reflected secondary impedance.

The output of the oscillator is stepped up by T2001 and applied via a conventional solid state tripler network consisting of CR2050 through CR2052 to the post-deflection accelerator of the cathode-ray tube.

The negative high-voltage supply is derived from a tap on the secondary winding of transformer T2001 which is connected to a half-wave rectifier CR2001. The rectified output of  $-1440$  volts is capacitively filtered by C2008, C2009, and C2011 and provides the necessary operating potentials for the proper intensity and focusing of the cathode-ray tube.

Regulation of the high voltage negative supply is accomplished by sampling a portion of the rectified output and applying a correction signal back through the HV regulator Q2000 to Q2002 to the base of the HV oscillator Q2003. This action changes the amplitude of oscillation of Q2003 and T2001 in such a manner as to restore the high voltage output to its preset level. Potentiometer R2009R, HV ADJ, is provided to preset the output of the high-voltage supply to its proper level.

### 3-4. NORMAL SWEEP UNBLANKING

The cathode-ray tube used in this oscilloscope has two additional beam deflection plates which cut off the electron beam independently of the control grid. In beam gate blanking, the electron beam is always turned on and passes through an aperture in the

center of a blanking shield. Behind this shield is a set of deflection plates, one of which is connected to a fixed  $+50$  volt source, while the second deflection plate is connected to the unblanking gate from the X Plug-in. When the time base is sweeping, both beam gate deflection plates are at the same potential and the electron beam passes through the aperture in the blanking shield. When the sweep ends and the unblanking gate voltage increases, the beam is deflected behind the blanking plate and the screen is dark.

Beam control pulses (trace brightening and retrace blanking pulses) can easily be dc coupled since these beam deflection plates are electrically close to ground. Hence, the display is visible only during the forward sweep interval and is blanked during the retrace and lockout interval.

### 3-5. FAST SINGLE SWEEP UNBLANKING

A back-of-panel slide switch is provided on the high-voltage and high-frequency Main Frame models so that both NORMAL (beam gate blanking) and SINGLE SHOT (grid-cathode blanking) are available. Cathode drive for beam brightening is desirable when high writing rates are required to assure maximum beam current with minimum spot size.

When it is desired to record high-speed, single-shot transients, the back-of-panel Beam Brightening switch is set to FAST SINGLE SWEEP ONLY. This technique completely turns off the electron beam eliminating the possibility of film fogging and loss of information when the lens is open for an extended period.

## NOTES

# SECTION 4

## PERFORMANCE ASSURANCE TEST

### 4-1. MAINTENANCE CHECK TO ASSURE PERFORMANCE

The tests described in the paragraphs to follow should be performed by Instrument Test Departments and Maintenance Laboratories to certify proper performance of this instrument. These tests are divided into sections for simplification and to assist those test groups where complete checking is not mandatory, or where all test equipment is not available. Refer to Section 5, paragraph 5-7, for list of test equipment required.

#### NOTE

If this oscilloscope is checked by a Receiving Inspection laboratory, the tests outlined below are recommended to certify performance. This instrument has been thoroughly tested and aged at the factory. Nevertheless, rough shipment, extreme environments, or long idle periods may necessitate minor adjustments of the controls. Hence, it is suggested that the certifying engineer try the recommended adjustments not only for recentering the controls, but also to ascertain their range and to familiarize himself with this precision instrument. If, after performing all the tests outlined in the paragraphs to follow, the instrument will not perform to specification, the assistance of the local Fairchild Field Engineering representative should be requested.

### 4-2. CHECKING THE POWER SUPPLY

1. Check the line fuse(s) F101 for proper value: 3 amperes; an additional line fuse is provided in the "M" models: F150, 2 amperes.

2. Check fuses of the regulated supplies for proper value:

Regulated Supply	Symbol	Fuse Rating
-50 volts	F130	1 ampere
+50 volts	F120	1.5 amperes
+100 volts	F110	1 ampere
+200 volts	F102	0.5 ampere
Line	F101	3A SLO BLD

3. Examine the instrument for charred or mechanically damaged components. Correct all defects.

4. Apply power to the instrument through a variable voltage source (Variac, or an equivalent). Set the line voltage to 115 volts. (Double this value for 230-volt operation.)

5. Set up the oscilloscope to obtain six cycles of the calibrator signal.

6. Allow 20 minutes for warmup before making any adjustments.

7. Lower the line voltage to 105 volts (210 volts for 230-volt operation). The display should remain stable and must not be erratic. If instability is noted before the lower limit of the line voltage is reached, check operation of the low-voltage regulated power supplies as outlined in Section 5 of this Instruction Manual.

*Note:* Always check the regulated voltages starting with the -50-volt supply and ending with the +200-volt supply.

8. Raise the line voltage to 125 volts (250 volts for 230-volt operation). The display should remain stable and must not be erratic. If instability is noted before this upper limit of line voltage is reached, check operation of the low-voltage power supplies.

9. Reset the line voltage to 115 volts (230 volts for 230-volt operation).

### 4-3. CHECK RIPPLE OF LOW-VOLTAGE SUPPLIES

1. Use a Type 704 Test Oscilloscope with a Type 4290 Probe.

2. Ground all chassis to power-line ground.

3. Set the oscilloscope for ac coupled input and set Y sensitivity to 5 mv/cm.

4. Use AUTO triggering with line sync and set SWEEP RATE switch to 5 mS/CM.

5. Measure the amount of 120-cycle ripple at the output of each power supply as listed below. (For line frequencies other than 60 cycles, the ripple will be twice the line frequency.)

Regulated Supply	Ripple Voltage	Test Point
-50 volts	10 millivolts p-p max	TP1301
+50 volts	20 millivolts p-p max	TP1201
+100 volts	30 millivolts p-p max	TP1101
+200 volts	65 millivolts p-p max	TP1001

### 4-4. CALIBRATOR CHECK

#### a. Waveshape Check

1. Adjust the Type 704 Oscilloscope for a sensitivity of 20 mv/cm and connect the Y INPUT to the CAL pin jack on the front panel of the Main Frame via the Type 4290 Attenuator Probe.

2. Observe a 1 volt (5 cm) peak-to-peak, 60-cycle square wave; rise time to be less than 20  $\mu$ sec. Tilt and ringing should be less than 5% (50 mv or 2.5 mm).

## section 4 — performance assurance test

### b. Amplitude Accuracy (Optional Test)

*Note:* This check is not required on every oscilloscope.

1. Precisely calibrate the Type 704 Oscilloscope with the Ballantine Model 420 Calibrator. The oscilloscope is set up with the Type 4290 Probe at a sensitivity of 20 mv/cm.

2. Set the Ballantine Calibrator for a frequency of 1 Kc at an output of 1 volt peak.

3. Adjust oscilloscope for 5-centimeter vertical bar.

4. Transfer the Probe from the Ballantine Calibrator to the 1 volt pin jack. Note Calibrator amplitude

to be 4.9 to 5.1 cm (1 volt  $\pm 2\%$ ). Avoid errors by using the anti-parallax scale.

### 4-5. CHECKING CRT GEOMETRY ADJUSTMENT

Set Y VOLTS/DIV switches to CAL and SWEEP RATE switches to 5 mS/DIV. Note the steady square wave patterns on the screen for each beam. The display should fall within a 6 cm x 10 cm and a 5.75 cm x 9.75 cm frame. Refer to the paragraph entitled "CRT Adjustments," in Section 5 of this Instruction Manual for further details.

# SECTION 5

## MAINTENANCE AND RECALIBRATION

### 5-1. INTRODUCTION (Figure 5-1)

This section of the Instruction Manual contains service information and procedures for internal adjustments. Refer to Figure 5-1 for an over-all functional block diagram of the Type 766H system.

#### WARNING

WHEN THE COVERS ARE REMOVED FROM THE INSTRUMENT FOR SERVICING, EXERCISE CAUTION WHILE THE POWER IS ON.

To gain access to the chassis for service, remove the side and rear covers. This will expose all of the transistors and service adjustments for normal maintenance.

### 5-2. REMOVAL AND REPLACEMENT OF PARTS

If it is necessary to order a replacement component from the factory, always give the Type Number and Serial Number of the instrument. Before ordering parts for in-warranty replacement or purchasing them for out-of-warranty replacement, be sure to consult the Parts List in this manual. The Parts List gives the values, tolerances, ratings, and the factory part number for all electrical components used in the instrument. This will help to expedite service.

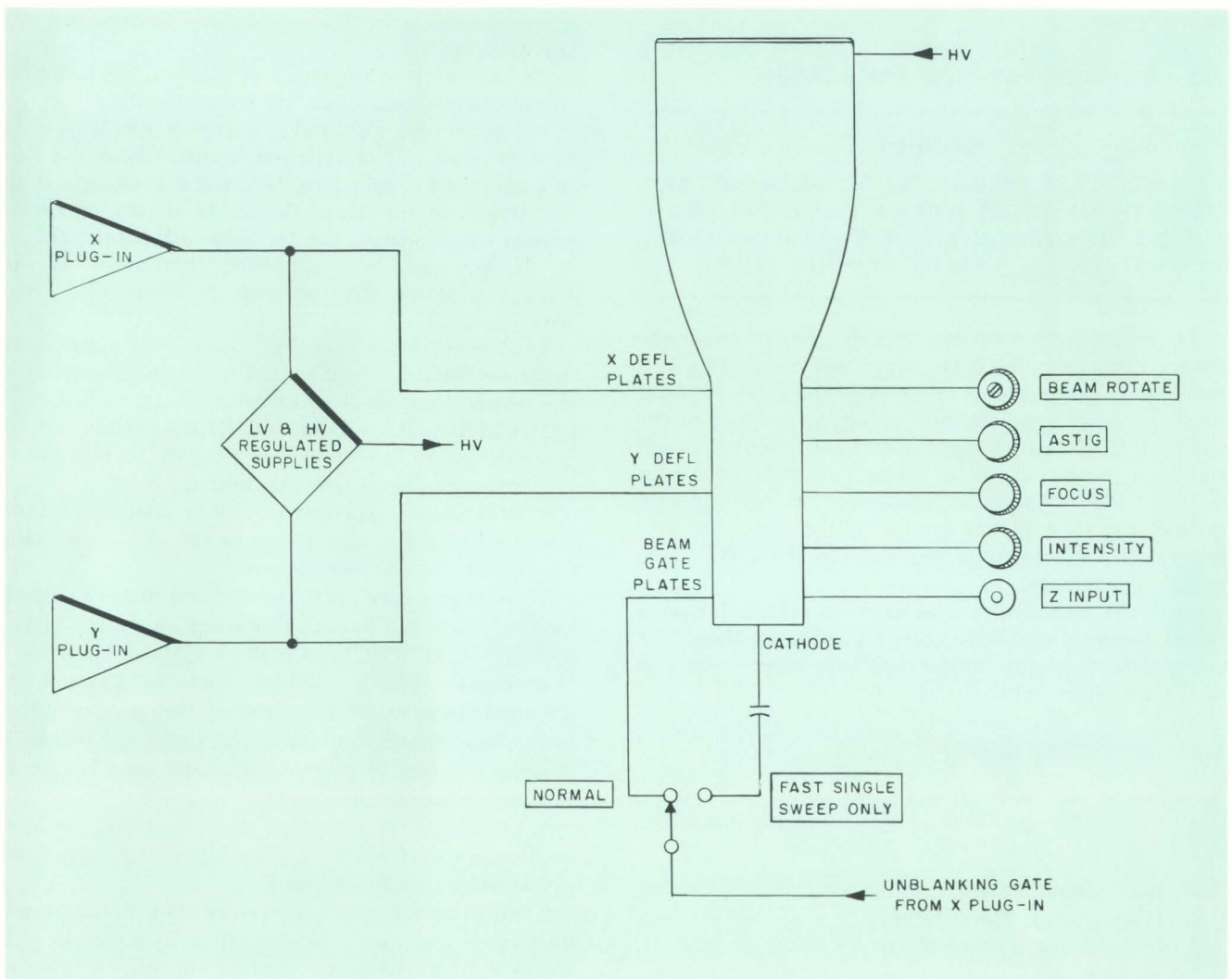

Figure 5-1. Over-all System Functional Block Diagram

## section 5 – maintenance and recalibration

Since your instrument left the factory, some of the parts may have been superseded by improved components. In such cases, the part numbers of these new components will not be listed in your Parts List. However, if you order a part from the factory and it has been superseded by an improved component, the new part will be shipped in place of the part ordered.

It is the aim of the Fairchild organization to make available the most reliable commercial oscilloscopes within the state of the art and to provide services which will help the user to rapidly restore any of our equipment to its specified performance. Your local Field representative maintains a limited number of spare parts. Also, the factory may be asked to airship replacement parts on a rush basis.

The procedure for replacing most parts in this instrument is obvious, therefore specific instructions for their removal are not required.

*Note:* Be sure and replace the beryllium oxide insulating washers (they serve as heat sinks) on the transistors that require them. Always grease these heat sinks with Dow Corning silicone grease for optimum heat transfer.

### 5-3. CATHODE-RAY TUBE REPLACEMENT

#### CAUTION

THE CATHODE-RAY TUBE SHOULD BE HANDLED WITH GREAT CARE TO PREVENT BREAKAGE AND/OR SERIOUS PERSONAL INJURY FROM FLYING GLASS.

To remove the cathode-ray tube, first remove the covers, disconnect the tube socket, HV anode cap, and the 4 leads connected at the neck of the tube. Remove the bezel and loosen the tube clamp at the base of the CRT. Pull the cathode-ray tube straight out through the front panel. Be careful not to break the neck pins on the CRT as the tube is removed. Install the new cathode-ray tube by the reverse of the foregoing procedure. Be sure to align the scale to the CRT trace and scan aperture.

After the cathode-ray tube has been replaced, it may be necessary to recalibrate. Special attention should be given to recalibration of the time base sweep rates and to the amplifier sensitivities.

### 5-4. SERVICING HINTS

Although this is a complex electronic instrument, trouble may be localized to the following basic circuits:

1. Low-voltage Power Supply
2. High-voltage Power Supply
3. Cathode-ray Tube Circuit
4. X Plug-in
5. Y Plug-in

Whenever trouble occurs in this instrument, first try to localize it to one of these basic circuits.

There is no simple way of locating troubles. An understanding of the functions of the circuits is the best help. With an understanding of the circuit operation, it will be possible to make a good guess at the general source of troubles from the symptoms. As an aid in trouble shooting this unit, refer to the system block diagram in this Section and also to the schematics.

To keep electronic units operating at top performance, it is desirable to check the equipment at regular intervals. The period between checks will depend on the installation and the conditions of operation. For these regular checks, clean all dust and dirt from the unit using a light air blast or soft brush. However, to insure the reliability of measurements, we suggest that you recalibrate this instrument after each 500 hours of operation or every six months if used intermittently. Also, the calibration of a unit should always be fully checked and adjusted after the repair or replacement of any component in the unit. The complete adjustment procedure for this unit is given in this Section of the Manual.

In the event of improper equipment performance, the following suggestions are recommended:

1. Remove the side and rear covers and inspect for broken wires and faulty components. Check the fuses in each power supply buss. Measure the voltages at the test points in the Main Frame. If all the above are within specifications, the problem will most likely be in the plug-ins. It is suggested that other plug-ins known to be operating properly be inserted on a substitution basis.

2. Whenever an apparent trouble is pin-pointed, make sure that it is not caused by improper setting of the panel controls. For instance, if the TRIGGER COUPLING, SLOPE, or SOURCE controls are improperly set on the Time Base Plug-in, then apparent triggering problems are manifested.

3. When using accessory probes or adapters, be sure the trouble is *not* originating in the accessory before suspecting the oscilloscope itself.

4. When it has been determined that a specific trouble exists and has been localized to a given circuit within a given unit, then make a visual inspection of that circuit. Many troubles, such as loose wires, scorched parts, may be exposed by this method. Obviously you should find and eliminate the cause of charred resistors or over-stressed capacitors before replacing damaged component.

5. Localizing the trouble is made easier by use of an oscilloscope to check waveforms. Use a high-impedance probe while trouble shooting.

6. Sometimes it may be necessary to move the plug-in unit from one cavity to the other in order to gain access to that particular part of the circuit that requires checking. A Type 4294 Extension Cable Acces-



sory is available and permits the plug-in unit to be operated while extended through the front of the oscilloscope.

7. If trouble is isolated to one of the plug-in units, refer to the appropriate module manuals for further information. If the trouble has been definitely isolated to the Main Frame or Indicator, then proceed as follows:

The first step in trouble shooting the Indicator Unit is to measure the power supply voltages at Test Points TP1301, TP1201, TP1101 and TP1001 located on the Main Frame. If all of the voltages are not as indicated, the trouble is in the low-voltage power supply or the power source. To check these, refer to the subsequent paragraph entitled "Trouble Shooting the Power Supply." If all these voltages are proper, the trouble resides in the cathode-ray tube circuit. In this instance, refer to the paragraph entitled "Trouble Shooting the Cathode-Ray Tube Circuit" in this Section of the manual.

### 5-5. TROUBLE SHOOTING THE POWER SUPPLY

#### WARNING

WHEN THE COVERS ARE REMOVED FROM THE INSTRUMENT FOR SERVICING, EXERCISE CAUTION WHILE THE POWER IS ON. The lower-voltage busses are potentially more dangerous than the cathode-ray tube potential because of the high-current capabilities and large filter capacitors employed in these supplies. When you reach into the instrument with one hand while it is turned on, do not grasp the metal frame with the other hand. If possible, stand on an insulated floor and use insulated tools. It is advisable to ground the third lead in the power cord whenever the instrument is in use.

As an aid in trouble shooting the power supply, refer to the functional block diagrams Figures 3-1 and 3-2, and to the low-voltage power supply schematic.

1. If the instrument fails to operate, including the pilot light, check the source of power and determine that the power cord is firmly in place. Then check fuses located at the rear of the instrument. (See Figure 5-2.)

*Note:* Disconnect the power cord when working on the transformer T1001 and associated circuits.

If the fuse is blown, replace it with one of the proper value and reconnect the line cord. If the new fuse blows, immediately check the power transformer for shorted primary or secondary windings. Shorted rectifiers in the secondary circuit will also blow the line fuse F101. Check for an open primary winding of T1001 if the line-fuse is good.

2. A thermal cutout switch is incorporated in this unit. If the instrument has been working but has just stopped, it may have overheated and tripped the thermal cutout switch. The thermal cutout switch will reset itself when the interior temperature of the instrument drops to a safe value. Possible causes of overheating are: restriction of air circulation and high ambient temperature.

3. If the line voltage is within specified limits, and one of the regulated power supply output voltages is not correct, check that particular regulator circuit. Each of the regulated supplies is fused separately. These fuses should be checked and replaced if necessary with a new fuse of the proper value.

*Note:* Always check the regulated voltages starting with the  $-50$ -volt supply and ending with the  $+200$ -volt supply.

When the circuit ailment has been confined to a particular regulator, then one may trouble-shoot within this circuit to locate the defective component(s). The description of the circuit involved may prove useful when diagnosing circuit ailments.

4. If none of the regulated voltages are correct, then the trouble probably resides in the  $-50$ -volt regulated supply since this voltage serves as a reference level for the other three regulated circuits.

One cause of insufficient output voltage is low unregulated dc voltage which might be caused by an open or shorted rectifier diode.

5. If there is excessive ripple on any of the unregulated supplies, replace the filter capacitor(s).

### 5-6. TROUBLE SHOOTING THE CRT CIRCUIT

The intensity, focus, geometry, and calibration of the cathode-ray tube display depend on proper operation of the high-voltage supply. To isolate this trouble, remove the rear cover from the Main Frame. Measure the voltage at Test Point TP2001 *using caution*. This voltage reading should be between  $-1350$  volts and  $-1440$  volts with respect to ground. If necessary, adjust the HV ADJ potentiometer R2009R for proper voltage. Remove power and measure the resistance of the primary and secondary windings of high-voltage transformer T2001. The resistance across the primary winding should measure around 5 ohms. Measure the resistance of the secondary winding from the anode of CR2052 to ground; it should measure around 175 ohms.

Also, measure the voltages at other points in the circuit for which typical values are given on the high-voltage power supply schematic. If all of these voltages check out correctly, then the trouble may reside with the cathode-ray tube itself which should be checked.

If the low-voltage power supply is operating normally, but no spot or trace is visible on the screen, then the trouble might be a defective cathode-ray tube, a defect in the CRT circuitry including the high-

## section 5 – maintenance and recalibration

voltage supply, an unbalanced condition in either of the plug-in modules, or a defective unblanking circuit.

*Note:* To obtain a spot or trace on the screen, the cathode-ray tube must be unblanked.

Refer to the appropriate plug-in module Instruction Manual for further information.

### 5-7. TEST EQUIPMENT REQUIRED FOR SERVICE ADJUSTMENTS

#### a. Introduction

The adjustments outlined in the following paragraphs are based on the test procedure followed at the factory. All adjustments should be made at mid-line voltage, 115V/230V,  $\pm 2\%$ . To set up the Indicator Unit for calibration, insert an amplifier plug-in and a time base plug-in into the Main Frame. These plug-in modules are signal sources for the Main Frame and must be fully tested and certified units. No testing will be performed on the plug-ins for calibration of the Indicator.

#### b. Test Equipment Required (Equivalent may be substituted)

Equipment	Description
Volt-ohmmeter	— Simpson Model 260 or Triplet Model 630 20,000 ohms/volt sensitivity
Square Wave Generator	— Fairchild Type 791
Oscilloscope	— Fairchild Type 704 with anti-parallax scale (scale #4501 2001)
4290B	— 10:1 Passive Attenuator Probe
High-Voltage Meter	— Sensitive Research Model DCH-1
Autotransformer	— Powerstat, Variac; capable of varying line voltage of the instrument being calibrated
Digital Voltmeter	— Fairchild Type 7100A
AC Voltmeter	— Weston Model 433
Standard Amplitude Calibrator	— Ballantine Type 420
LC Meter	— Tektronix Type 130
Pulse Generator	— Hewlett-Packard Type 8000A
Oscillator	— Hewlett-Packard Type 650A

### 5-8. ADJUSTING THE LOW-VOLTAGE POWER SUPPLIES

Connect the autotransformer to a suitable power source and connect the oscilloscope to the output of this transformer. Turn on the instrument and set the output for the nominal operating voltage of the oscilloscope (115V for 115-volt operation or 230V for

230-volt operation). Allow the instrument to warm up for about 10 minutes.

*Note:* Do not adjust the  $-50$ -volt supply unless one or more of the supplies is actually out of tolerance or unless a complete calibration of the instrument is desired.

Use a John Fluke Voltmeter and adjust or check the supplies in the sequence and at the Test Points listed.

Regulated Supply	Tolerance	Test Point	Service Adjustment
$-50$ V	$\pm 100$ mv	TP1301	R1303 $-50$ V ADJ
$+50$ V	$\pm 100$ mv	TP1201	R1213 $+50$ V ADJ
$+100$ V	$\pm 150$ mv	TP1101	R1112 $+100$ V ADJ
$+200$ V	$\pm 250$ mv	TP1001	R1012 $+200$ V ADJ

Vary the autotransformer output voltage between 105 volts and 125 volts and check to see that all regulated supplies stay within  $\pm 1\%$  except the  $+200$  volt supply which is  $\pm 1.5\%$ . For 230-volt operation, vary the autotransformer output between 210 volts and 250 volts and check to see that all voltages stay within the above tolerance.

### 5-9. HIGH-VOLTAGE ADJUSTMENT

Use Sensitive Research High Voltage Meter and Probe with caution.

Apply Probe to the  $-1350$ V Test Point TP2001, and adjust R2009R (HV ADJ) for  $-1350$ V  $\pm 15$  volts.

### 5-10. CRT ADJUSTMENTS

#### a. Graticule External to CRT

To align the trace to the graticule, proceed as follows:

1. Use recurrent sweep with no signal applied to vertical channel.
2. Set BEAM ROTATE control R2022 to mid-range.
3. Center trace and rotate CRT to match scale.
4. Tighten CRT clamp.

To align the graticule to the scan, proceed as follows:

1. Apply 60-cycle signal to the Y INPUT and adjust oscilloscope for full-screen deflection, one beam at a time.
2. Slow sweep rate to 50 ms/div. Note full raster display on screen.
3. Adjust eccentric cam to assure full 6-division coverage of scale and vertical CRT scan.

*Note:* This adjustment should only be necessary when the CRT has been removed or replaced. The BEAM ROTATE control should be used for any alignment discrepancies thereafter.

# maintenance and recalibration – section 5

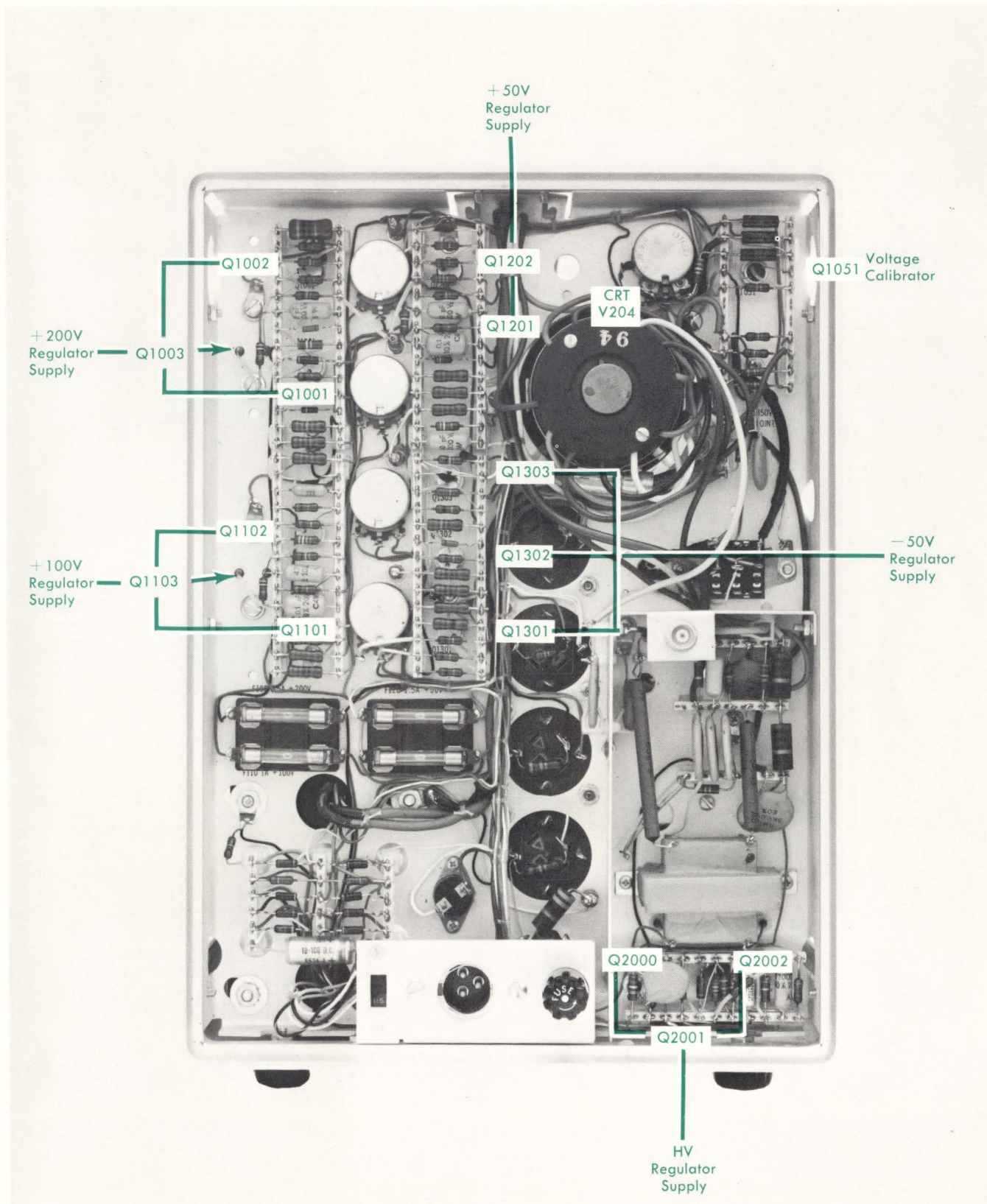

Figure 5-2. Type 766, Rear View Showing Transistors and CRT

## section 5 – maintenance and recalibration

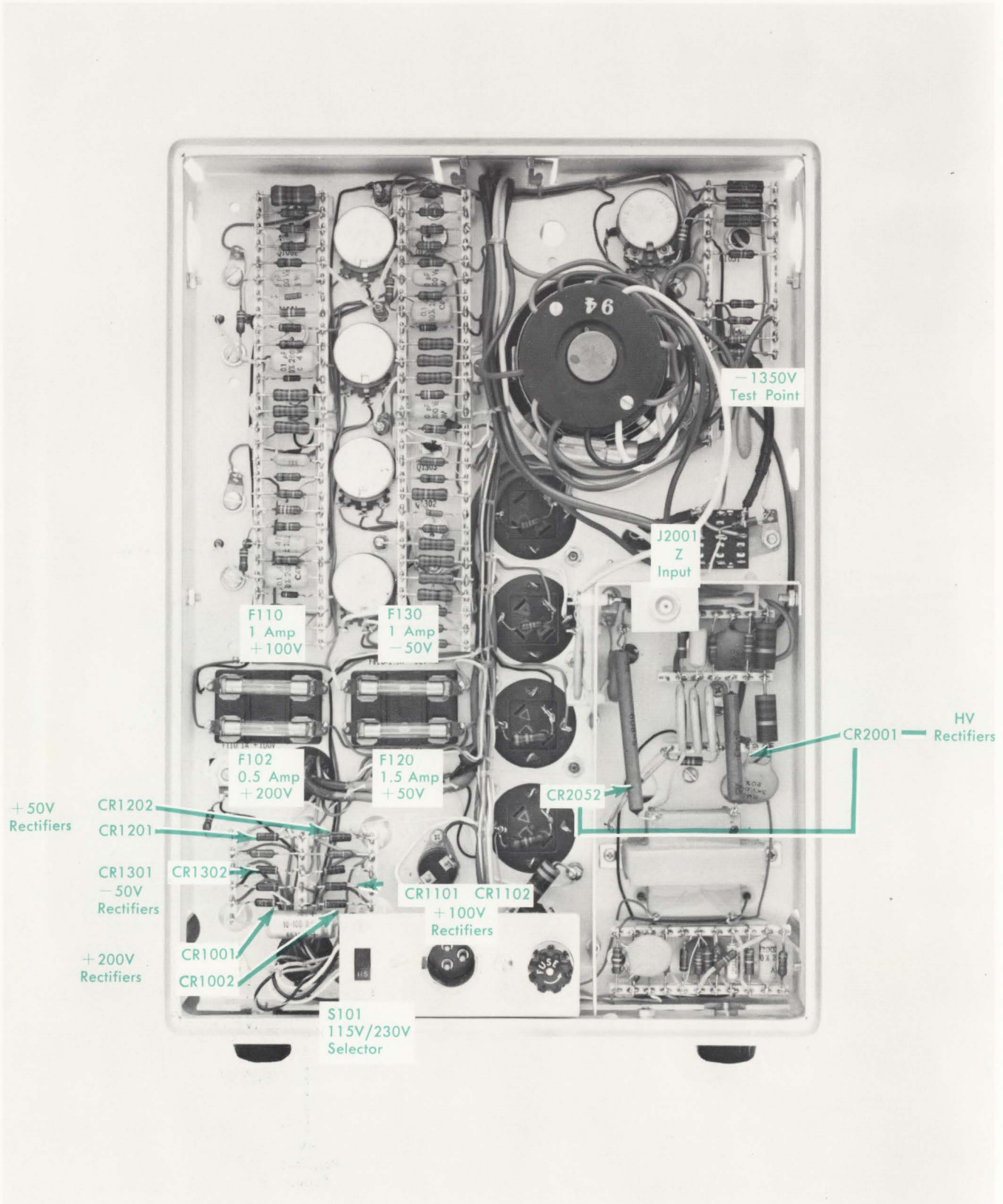

Figure 5-3. Type 766, Rear View Showing Fuses, Switch and Diodes

## maintenance and recalibration – section 5

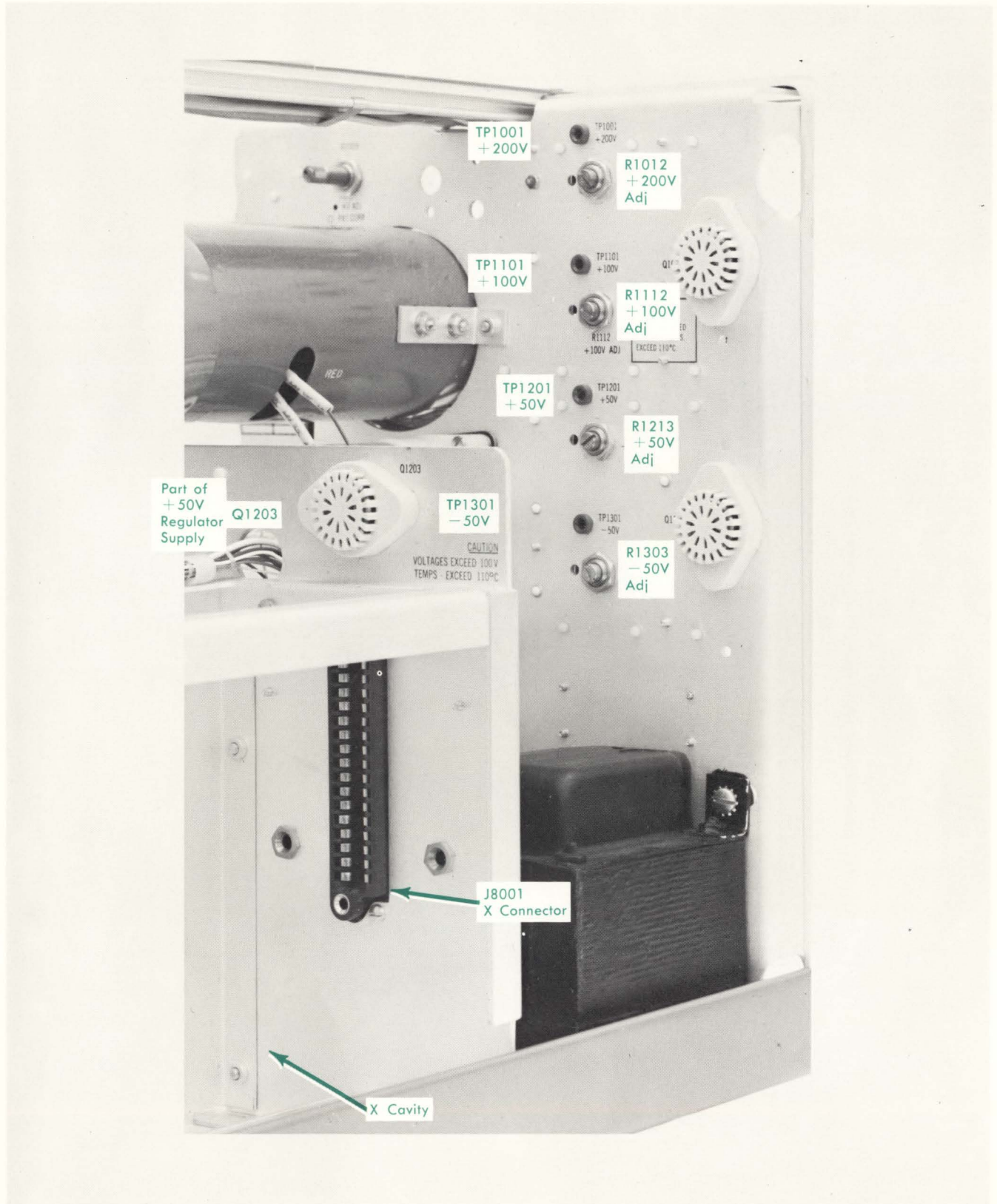
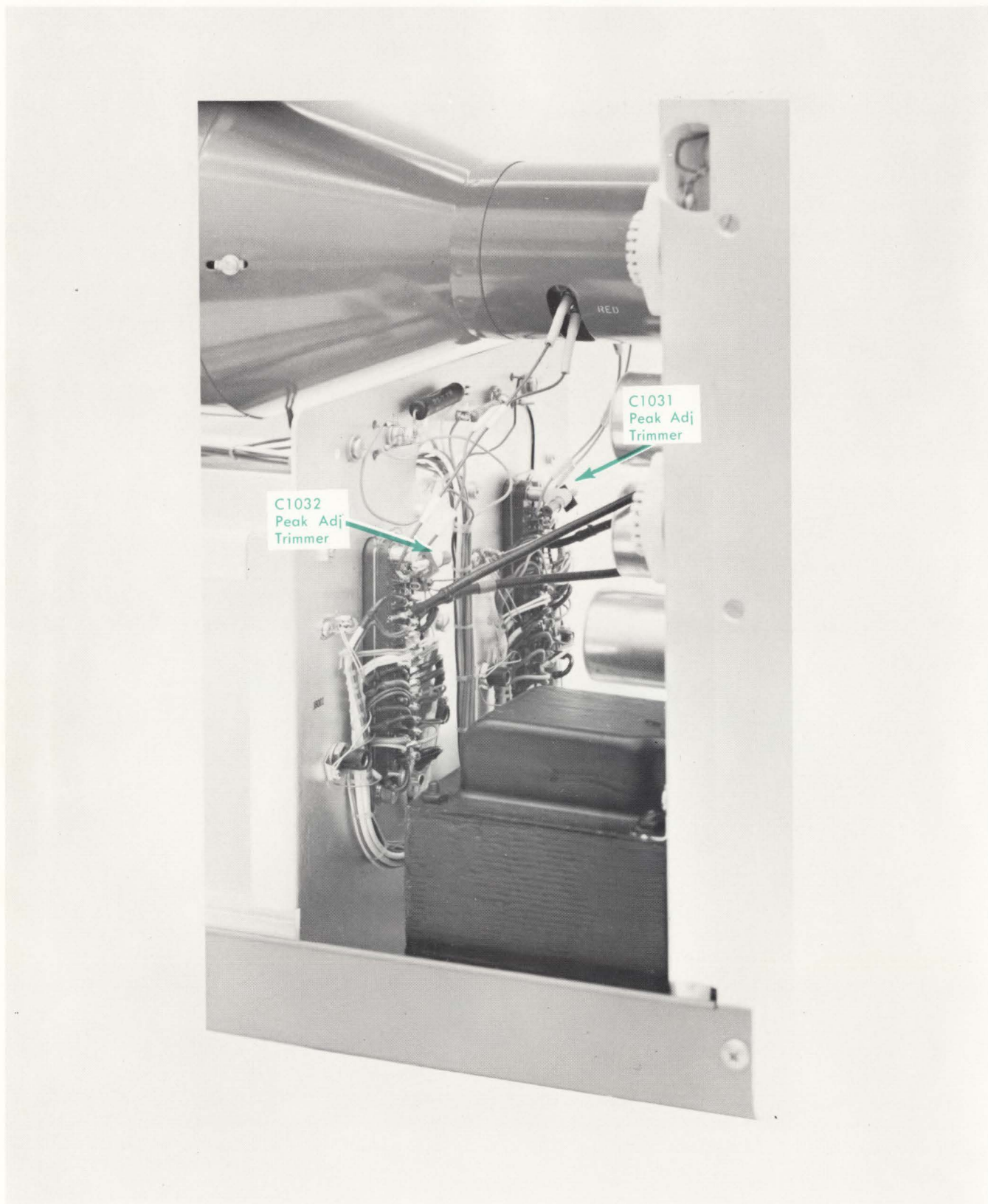

Figure 5-4. Type 766, Top View of Chassis Showing Test Points, Transistors and Adjustments

## section 5 – maintenance and recalibration



**Figure 5-5.** Type 766, Right Oblique View Showing X & Y Peaking Trimmers

# maintenance and recalibration – section 5

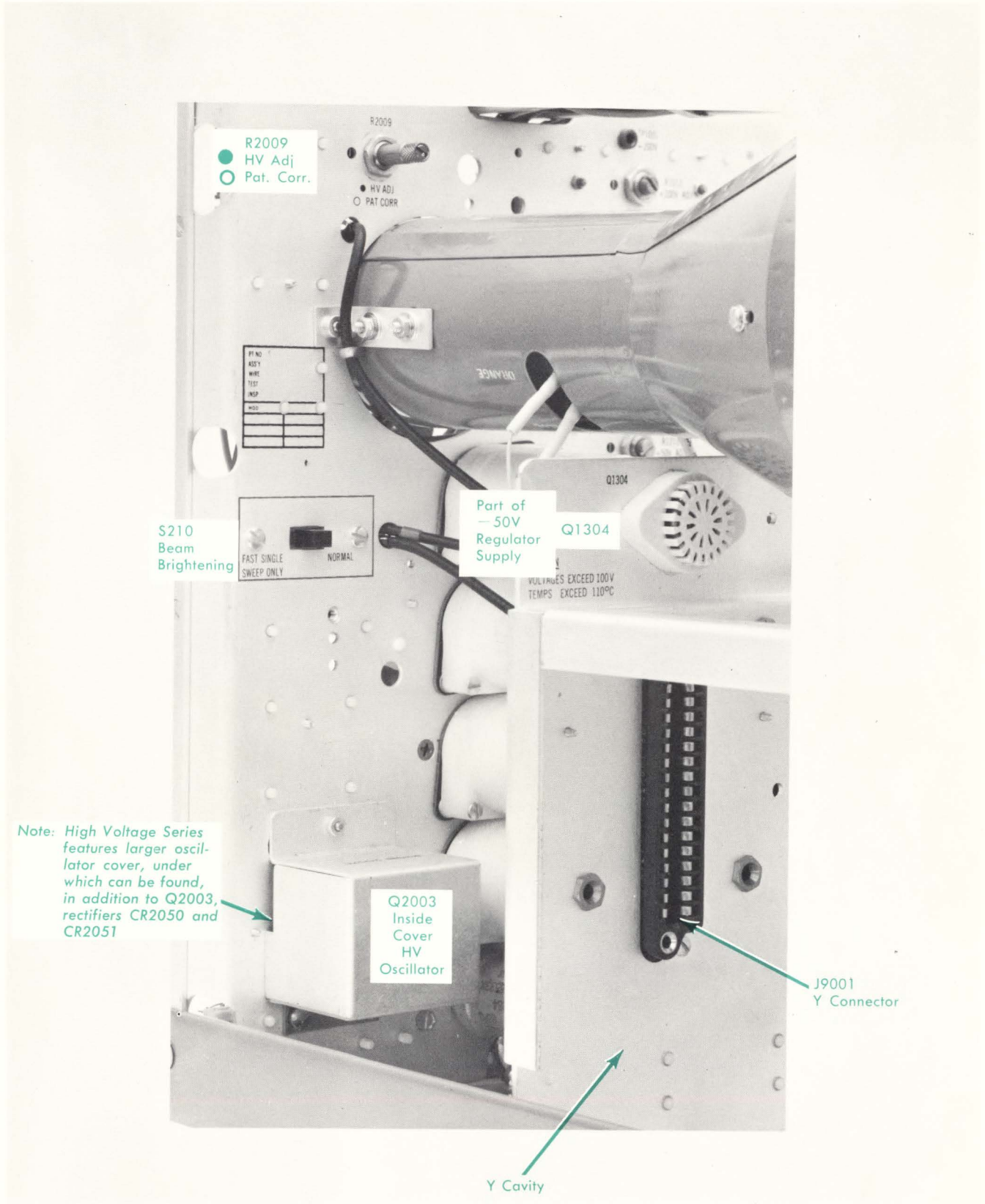

Figure 5-6. Type 766, Left Oblique View Showing Transistors, Switch and Adjustment

# section 5 – maintenance and recalibration

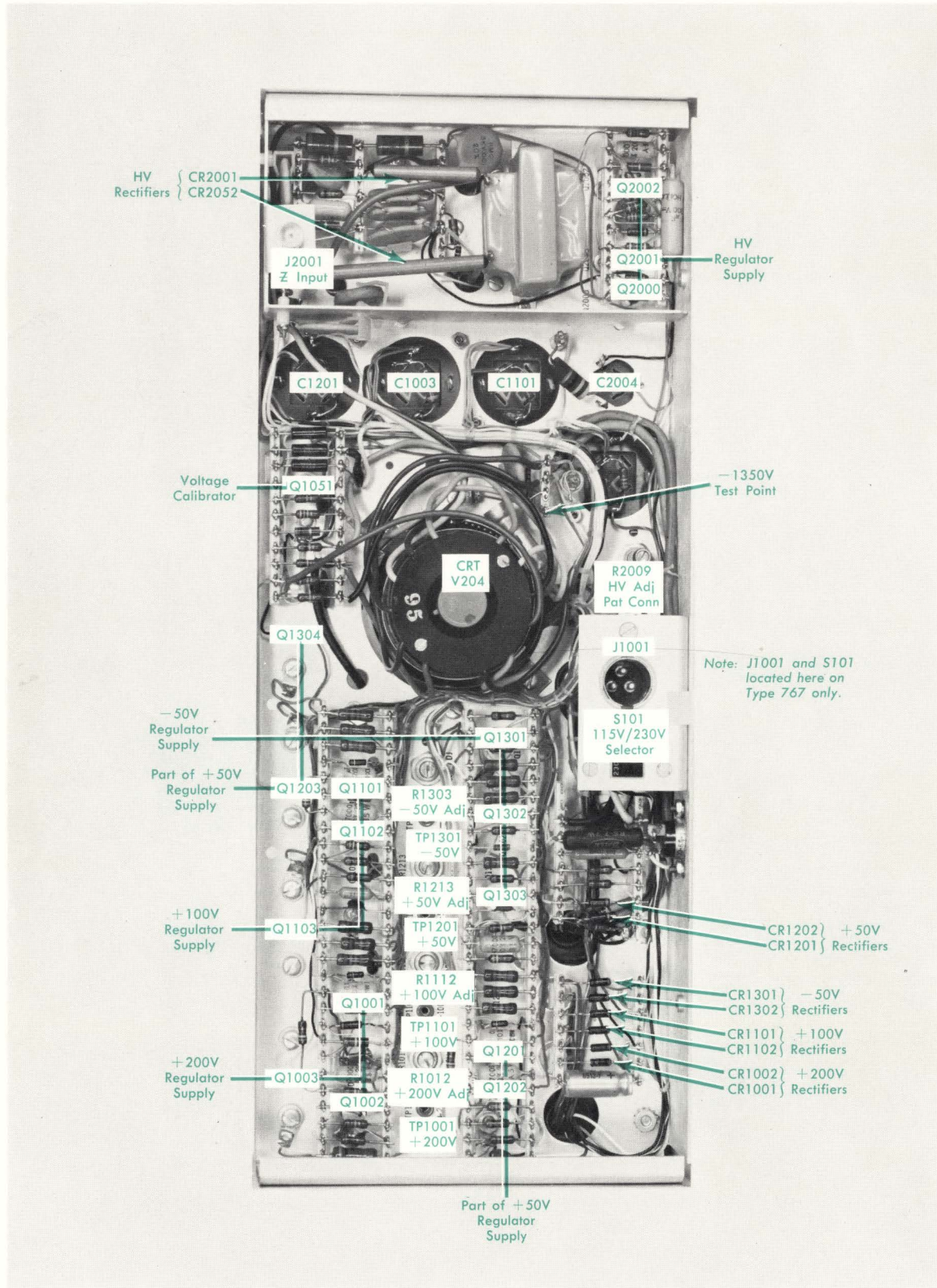

Figure 5-7. Type 765, 767 Component Location (Rear View)



# maintenance and recalibration – section 5

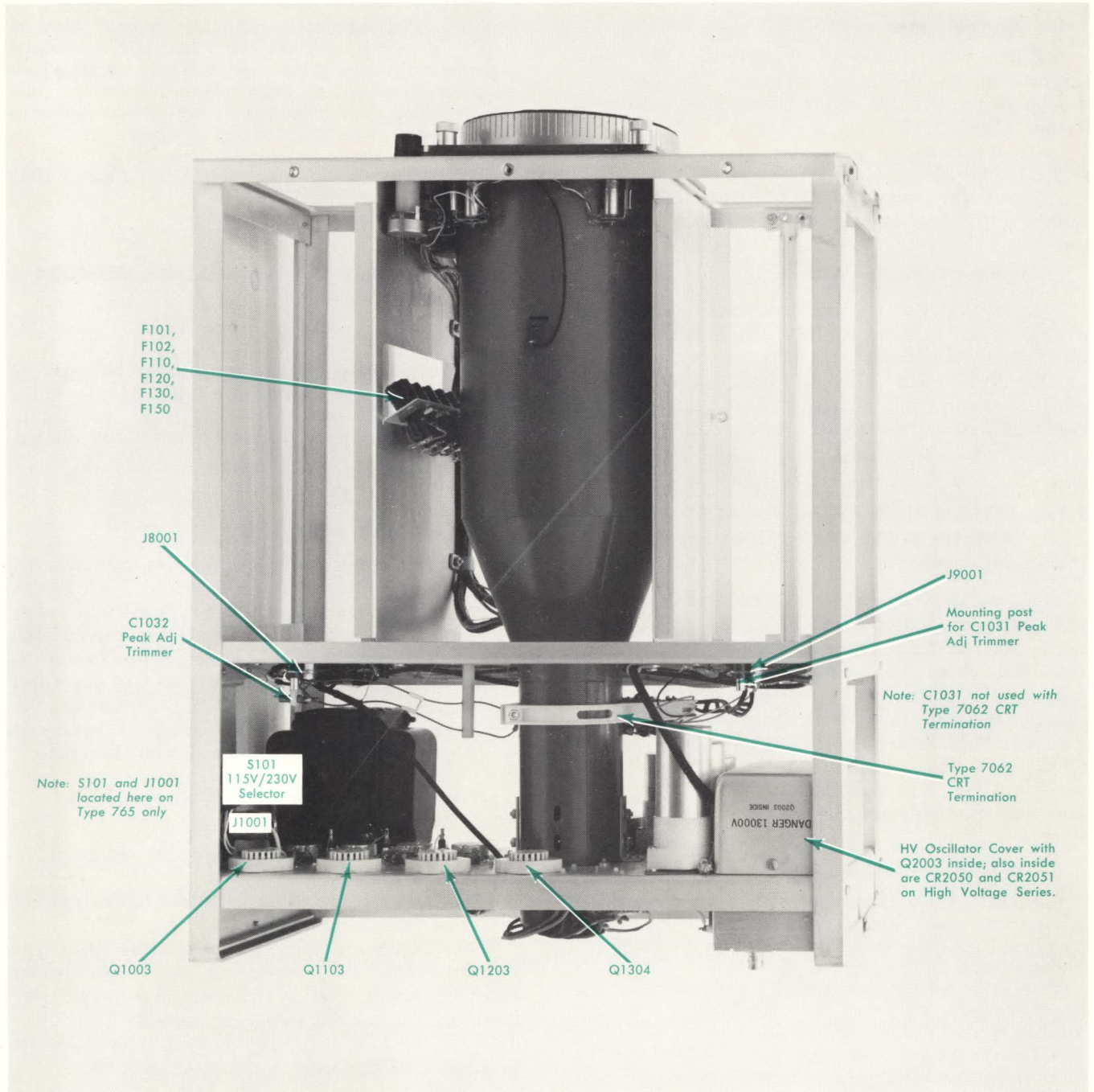

Figure 5-8. Type 765, 767 Component Location (Top View)

## section 5 – maintenance and recalibration

### b. Graticule Internal to CRT

1. Where the graticule is internal to the CRT, align the tube so that the horizontal center line is perpendicular to the left side of the frame, using a suitable fixture. Clamp CRT.

2. Use recurrent sweep with no signal applied to the vertical channel.

3. Center trace and adjust BEAM ROTATE control R2022 until trace is parallel to horizontal lines of scale.

### c. Pattern Correction ADJ

1. Set Y VOLTS/DIV switch to CAL and SWEEP RATE switch to 5 mSEC/DIV. Note steady square wave pattern on screen.

2. Set PATTERN CORRECTION control R2009F, until the vertical and horizontal lines at the 6 x 10 cm edges are optimally straight.

*Note:* The display should fall within a 6 x 10 cm and a 5.75 x 9.75 cm rectangular frame.

## 5-11. SETTING MAIN FRAME CAPACITY FOR LV AND HV SERIES ONLY (C1031 and C1032)

### a. Introduction

The Low and High Voltage Main Frames are provided with a small trimmer capacitor mounted between pin 1 and pin 17 on the rear of both X and Y axis blue ribbon connectors. The purpose of these capacitors is to standardize the CRT deflection plate capacity between Type 766H Series of Main Frames. The standardization of these capacitors (C1031 and C1032) will allow interchangeability of plug-ins from one Main Frame to another, with a minimum of the high-frequency adjustments on both the X and Y Plug-ins.

### b. Adjustment Procedure

1. Select a capacitance meter that can compensate for test lead capacitance of up to 30 pf by means of a zero balance adjustment. The Tektronix Type 130 LC Meter is such an instrument.

2. Remove both plug-in modules, and disconnect the Main Frame power cord. Place the Main Frame and the LC Meter on a non-conductive surface.

3. Fabricate a test cable using one foot of RG-59B/U, UHF connector UG-176/U, and a 32-pin blue-ribbon connector. Attach the UHF connector to one end of the cable, and connect the center conductor and shield at the other end of the cable to blue-ribbon connector pins 1 and 17, respectively.

*Note:* Any shielded cable can be used, providing its capacitance is low enough to be compensated by the zero adjustments on the LC meter. Do not use clip leads or other temporary connectors as they tend to introduce excessive stray capacitance.

4. Connect the test cable to the UNKNOWN jack on the LC Meter and zero the meter.

5. Plug the test cable blue-ribbon connector into J9001. The LC Meter should read 12.5 pf. If not, adjust C1031 to obtain this reading.

*Note:* The capacitance value given here (and in step 6) does not represent the actual dynamic input capacitance as seen by the plug-in. This is of little consequence, however, as these measurements are sufficiently repeatable from unit to unit to enable accurate adjustment of the trimmer capacitor.

6. Perform the same measurement at jack J8001. The LC Meter should read 9 pf. If not, adjust C1032 to obtain this reading.

## 5-12. TYPE 7062 CRT TERMINATION NETWORK (H/F Series Only)

### a. Introduction

The Type 7062 CRT Termination Network is "standard equipment" with the High-Frequency Main Frame Oscilloscopes (Types 765H/F, 765MH/F, 766H/F, 766MH/F, 767H/F and 767MH/F). It has been provided to accommodate the Type 79-02A 100 Mc Dual Trace Amplifier.

### b. Installation Instructions

The Type 7062 is available as a kit to transform the H models to H/F models. If a Fairchild Type 79-02A is acquired at a later date and the Type 766H Series Oscilloscope has not been modified, then the installation of the Type 7062 CRT Termination Network is mandatory. However, this installation will not affect the operation of any other Fairchild amplifier plug-ins.

See Figures 5-9 and 5-10 for Installation Instructions and Figure 5-11 for the Interconnecting Diagram.

### c. Peaking Adjustments (C2053 and R2065) Figure 5-12

1. Hook up Test Equipment as indicated in Figure 5-12.

2. Tack the free end of the twin lead to the input of the Type 7062 Termination.

*Note:* Do not use alligator clips or other bulky type connectors that will introduce a large capacitive or inductive lump. A small jack such as a tube socket terminal or amphenol connector would be suitable.

3. Set the H.P. Type 8000A Pulse Generator for positive, 0.4-volt pulses on the CRT display.

4. Set R2065 LF PEAKING ADJ to mid-range. A termination bump should appear approximately 25 nanoseconds from the start of the pulse.

5. Adjust HF peaking trimmer C2053 to produce a positive bump 0.2 division in amplitude.

6. Remove Type 79-02A Dual Trace Plug-in, the Type 4294 Extension Cable, and disconnect the long twin lead.

7. Install the Type 7062 with its normal 6¾" length of twin lead.

8. Install a Type 76-08 or other lower frequency amplifier plug-in in the Y cavity.

9. Adjust LF PEAKING ADJ R2065 for flat top.

## maintenance and recalibration – section 5

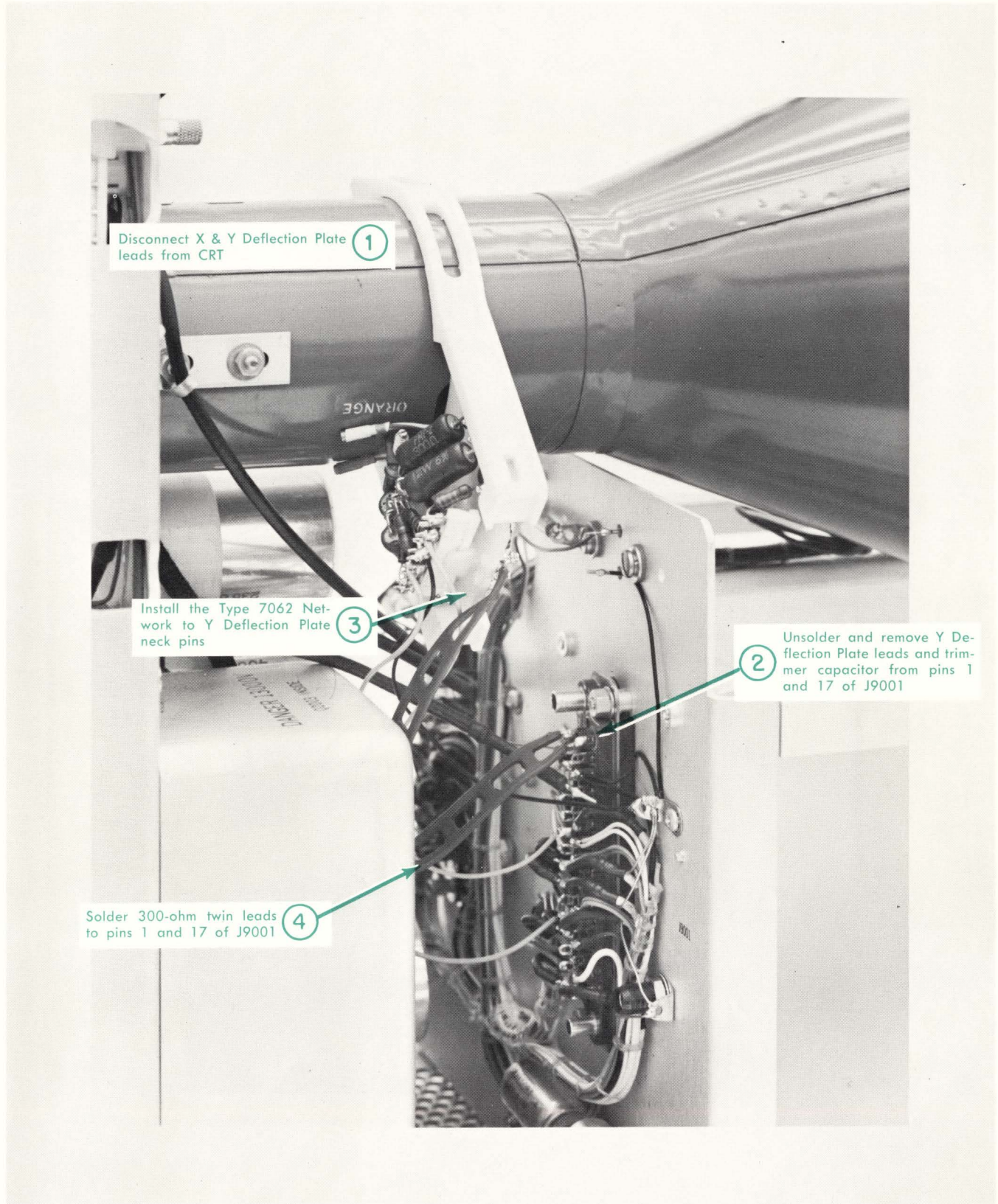

Figure 5-9. Type 7062 CRT Termination Installation Instructions

## section 5 – maintenance and recalibration

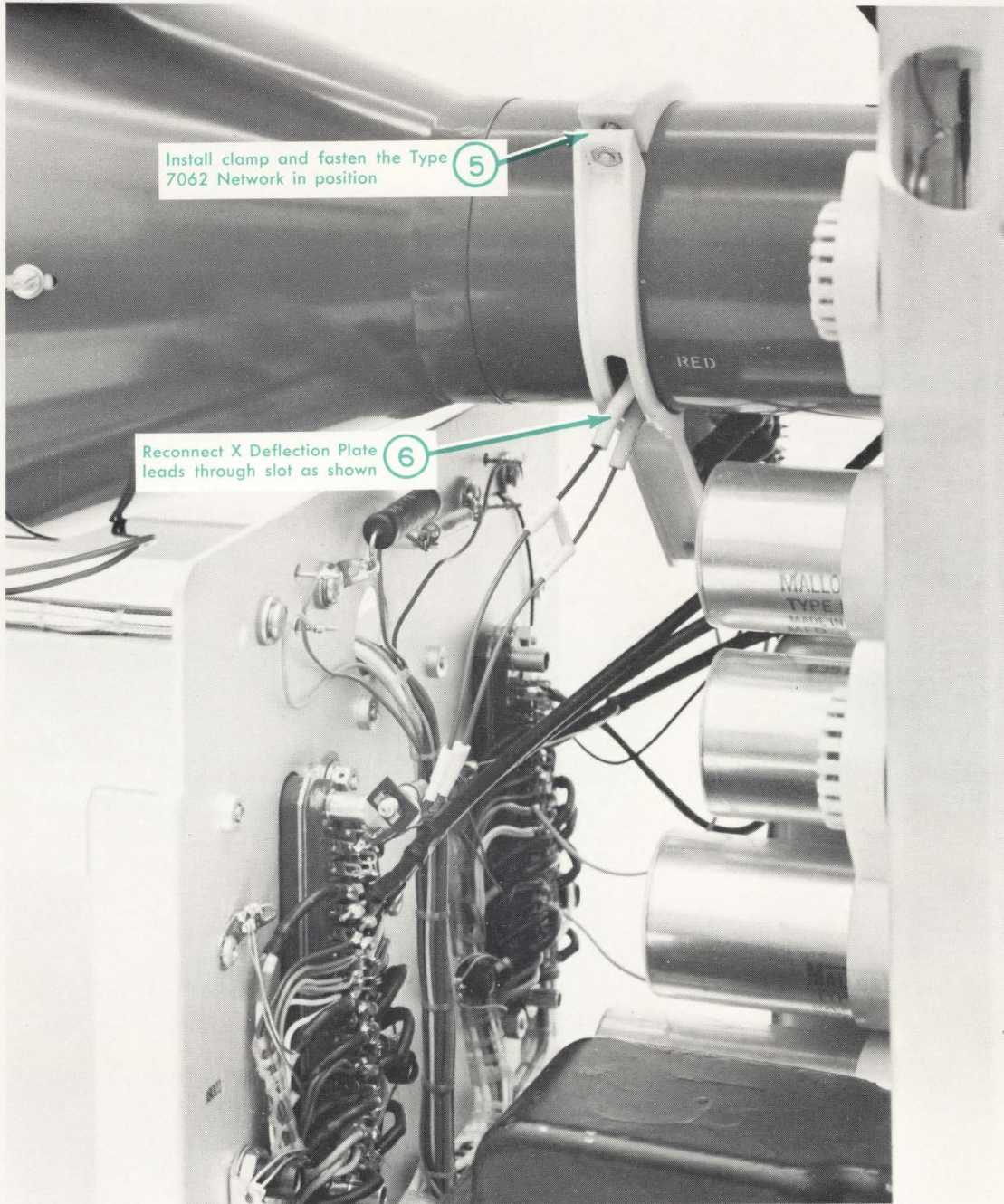
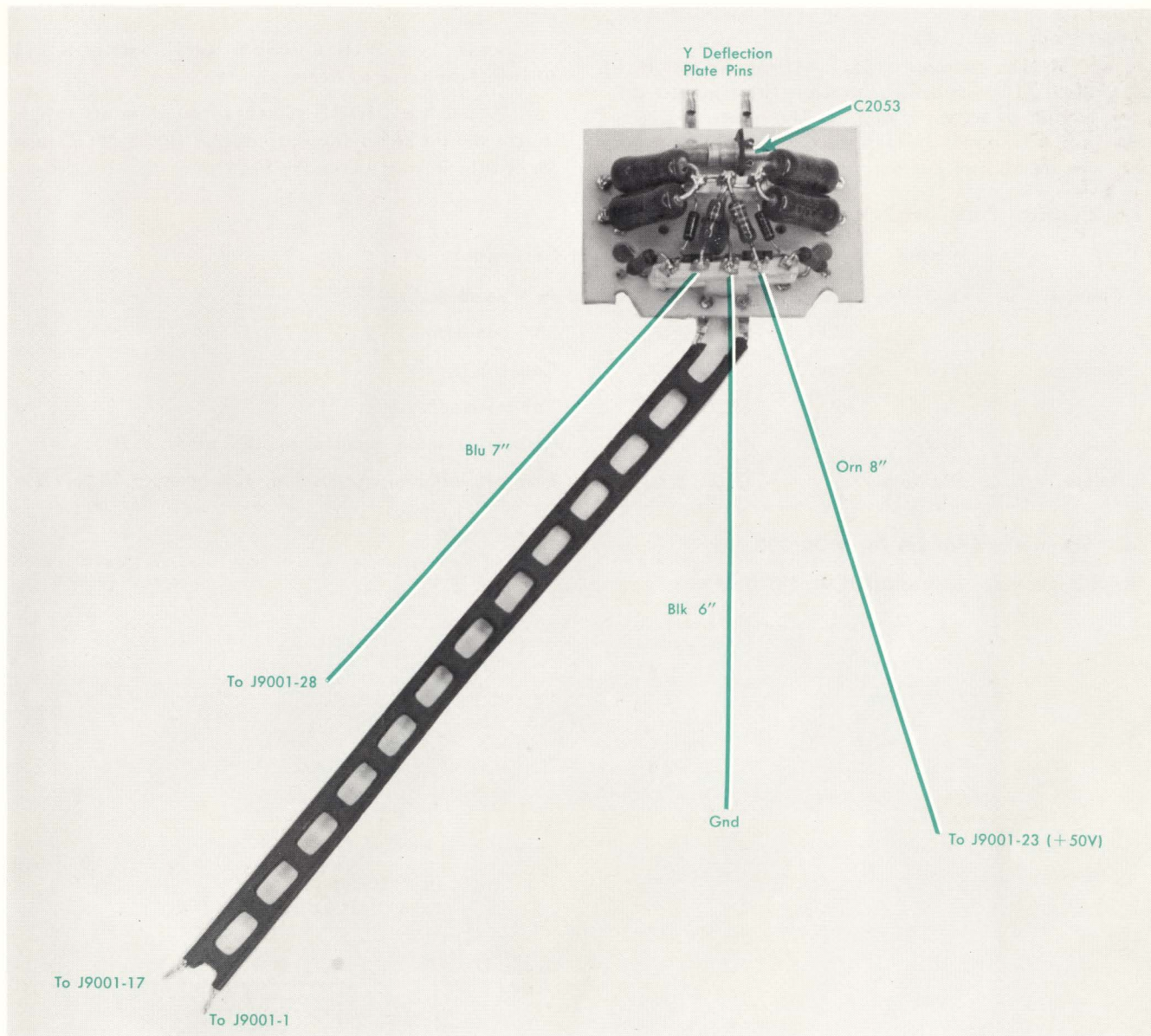

Figure 5-10. Type 7062 Installation Instructions



**Figure 5-11. Type 7062 Interconnecting Diagram**

## 5-13. SUPPLEMENT FOR TYPE 766H MOD 102 OSCILLOSCOPE

### a. Introduction

The Type 766H Mod 102 Main Frame is identical to the regular Type 766H except for the addition of the A  $\pm$  B DC OFFSET potentiometer R1071 and minor Parts List and Schematic revisions as indicated elsewhere in this paragraph.

### b. Adjustment of A $\pm$ B DC Offset POT R1071

When the A  $\pm$  B DC OFFSET potentiometer is properly adjusted, there will be no depositing of the trace when the MODE switch is set to the ADDED position. To properly adjust, proceed as follows:

1. Set up Time Base Plug-in for automatic triggering to obtain a reference trace on the screen.
2. Set MODE switch to CH 1 and position trace to screen center with CH 1 POSITION control.
3. Set MODE switch to CH 2 and position trace to screen center with CH 2 POSITION control.

## section 5 – maintenance and recalibration

4. Set MODE switch to ADDED. Measure the number of graticule divisions the trace has shifted or is offset from screen center.

5. Set MODE switch to ALT. Using Channels 1 and 2 POSITION controls, position the trace to the opposite side of screen center by the exact displacement that was noted in step 4. For example, if the trace was offset from screen center by  $1\frac{1}{2}$  divisions,

then position the trace  $1\frac{1}{2}$  divisions below screen center.

6. Set the A  $\pm$  B DC OFFSET potentiometer R1071 to bring the trace to screen center.

7. Rotate the MODE switch throughout its range. There should be no deposition of the trace. Repeat preceding steps if necessary to achieve this condition.

### c. Electrical Parts List Revision for MOD 102

	Symbol		Part Number	Description
Change	J1005	from	0904 4381	Jack tip, black
		to	0905 7610	BNC connector
Change	W1001	from	5030 1390	Cable Assembly
		to	5030 1890	Cable Assembly
Add	R1071		0109 1410	Resistor, variable, composition, 50K ohms, $\pm 20\%$
Delete	R1055 & R1056		0107 2631	Resistor, variable, composition, 30K ohms, $\pm 20\%$ , $\frac{1}{2}$ W

### d. Schematic Changes for MOD 102

Revise schematic as indicated in sketch below.

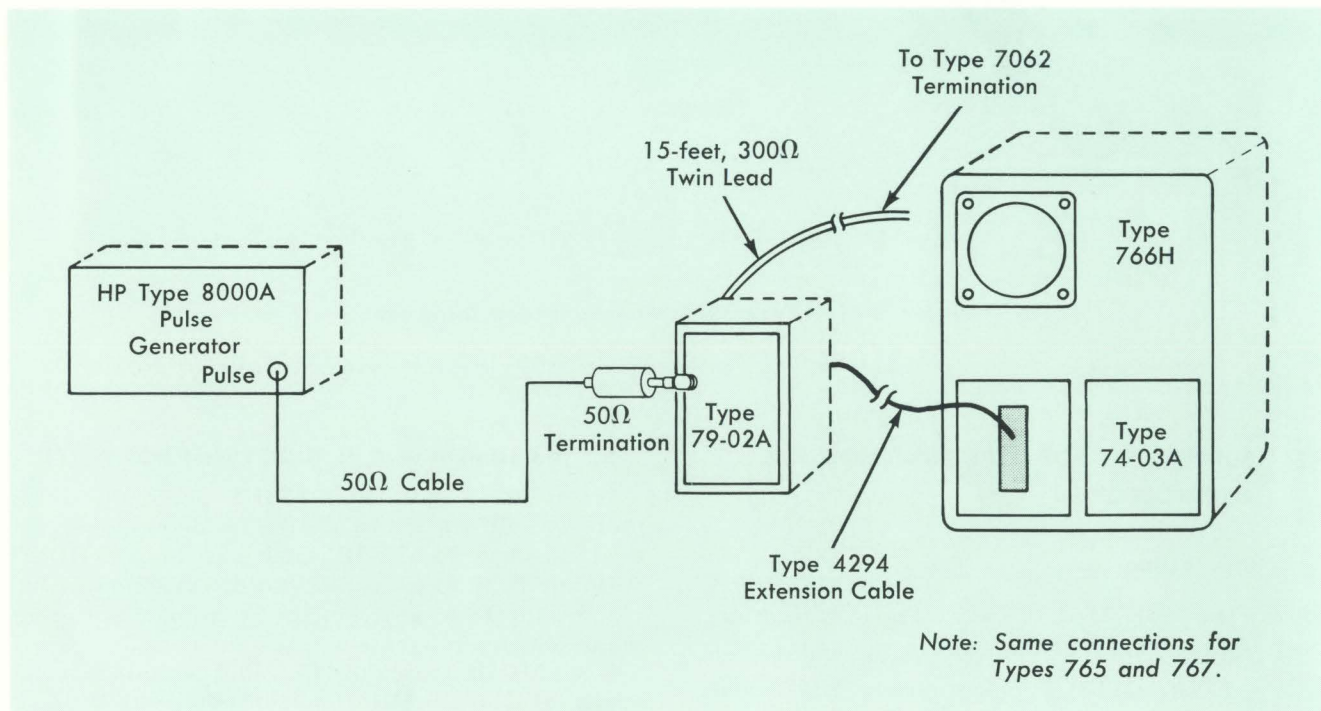
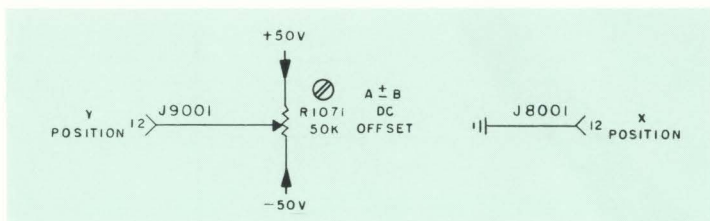

Figure 5-12. Peaking Adjustment Hook-up Diagram

# SECTION 6A

## ELECTRICAL PARTS LIST

### AND SCHEMATIC

#### INTRODUCTION

The Fairchild Types 765, 766, and 767 Family of Oscilloscopes are available in three basic form factors: bench, rack, and portable models. The Portable models are identified by the Type 765 numerical Series; the Bench models by the Type 766 numerical Series, and the Rack-mounted models by the Type 767 numerical Series.

In addition, there are alphabetical suffixes appended

to the numerical series to identify special electronic circuits. The suffix H denotes the high-voltage oscilloscope with an accelerating potential of 13 Kv. The low voltage option is 5 Kv and these series oscilloscopes are identified by the absence of the H alphabetical suffix. The suffix F denotes the high-voltage, high-frequency model; the suffix M denotes the militarized model.

The Type 766H Series Oscilloscope may be categorized into three basic Series as indicated in Table given below.

SERIES	TYPES
LOW VOLTAGE	765, 765M, 766, 766M, 767, 767M
HIGH VOLTAGE	765H, 765MH, 766H, 766MH, 767H, 767MH
HIGH FREQUENCY	765H/F, 765MH/F, 766H/F, 766MH/F, 767H/F, 767MH/F

Symbol	Part Number	Description	Recommended Vendor		Symbol	Part Number	Description	Recommended Vendor	
			Code	Type				Code	Type
<b>CAPACITORS</b>									
Notes: 1. All capacitors are fixed, ceramic, and 500V unless otherwise specified; pf ( $\mu\text{pf}$ ) denotes picofarads.									
2. GMV denotes Guaranteed Minimum Value.									
C1001 &					C1208	0327 1890	electrolytic, 25 $\mu\text{f}$ , +100		
C1002	0326 4620	5000 pf, GMV	ERC	801			-10%, 150V	MAL	TCW
C1003	0319 3880	electrolytic, 300 $\mu\text{f}$ , +100	MAL	FP	C1301	0319 3890	electrolytic, 400 $\mu\text{f}$ , +150	MAL	FP
		-10%, 250V					-10%, 150V		
C1004	0326 4520	1000 pf, GMV	ERC	831	C1302	0326 9550	electrolytic, 10 $\mu\text{f}$ , +100	SPG	30D208A1
C1006	0326 7840	plastic, 0.047 $\mu\text{f}$ , $\pm 10\%$ , 200V	AMX	C296AB			-10%, 100V	CRL	DDM
C1007	0326 7860	plastic, 0.1 $\mu\text{f}$ , $\pm 10\%$ , 200V	AMX	C296AB	C1303	0319 1060	0.01 $\mu\text{f}$ , +60 -40%, 150V		
C1008	0319 1050	0.02 $\mu\text{f}$ , +60, -40%, 150V	CRL	DDM	C1304	0326 7840	plastic, 0.047 $\mu\text{f}$ , $\pm 10\%$ , 200V	AMX	C296AB
C1009	0327 1890	electrolytic, 25 $\mu\text{f}$ , +100	MAL	TCW	C1306	0319 1050	0.02 $\mu\text{f}$ , +60 -40%, 150V	CRL	DDM
		-10%, 150V			C1307	0326 4520	1000 pf, GMV	ERC	831
C1031 (HV and LV Series only)	0319 1251	variable, 0.4-2.5 pf, 350V	ABD		C1308	0327 1890	electrolytic, 25 $\mu\text{f}$ , +100	MAL	TCW
C1032	0319 1251	variable, 0.4-2.5 pf, 350V	ABD				-10%, 150V	ERC	841
C1101	0319 3890	electrolytic, 400 $\mu\text{f}$ , +150			C2003	0326 4660	0.02 $\mu\text{f}$ , GMV		
		-10%, 150V	MAL	FP	C2004	0327 6940	electrolytic, 25 $\mu\text{f}$ , +100	MAL	FP
C1102	0326 7840	plastic, 0.047 $\mu\text{f}$ , $\pm 10\%$ , 200V	AMX	C296AB			-10%, 100V	AMX	C296AB
C1103	0326 4520	1000 pf, GMV	ERC	831	C2005	0326 7880	plastic, 0.22 $\mu\text{f}$ , $\pm 10\%$ , 200V		
C1104	0326 7860	plastic, 0.1 $\mu\text{f}$ , $\pm 10\%$ , 200V	AMX	C296AB					
C1106	0319 1050	0.02 $\mu\text{f}$ , +60 -40%, 150V	CRL	DDM	C2007 (HV and HF Series only)	0327 6890	electrolytic, 500 pf, +50	CDE	
C1107	0327 1890	electrolytic, 25 $\mu\text{f}$ , +100	MAL	TCW			-20%, 12KV		
		-10%, 150V			C2008 &				
C1201	0327 6930	electrolytic, 800 $\mu\text{f}$ , +100	MAL	FP	C2009	0316 4930	0.01 $\mu\text{f}$ , +100 -0%, 2000V	RMC	2KV
		-10%, 150V			C2010	0327 6890	500 pf, +50 -20%, 12KV	CDE	
C1203	0326 4520	1000 pf, GMV	ERC	831					
C1204	0326 7840	plastic, 0.047 $\mu\text{f}$ , $\pm 10\%$ , 200V	AMX	C296AB	C2011	0316 4930	0.01 $\mu\text{f}$ , +100 -0%, 2000V	RMC	2KV
C1206	0326 7860	plastic, 0.1 $\mu\text{f}$ , $\pm 10\%$ , 200V	AMX	C296AB	C2012	0326 7840	plastic, 0.047 $\mu\text{f}$ , $\pm 10\%$ , 200V	AMX	C296AB
C1207	0319 1050	0.02 $\mu\text{f}$ , +60 -40%, 150V	CRL	DDM	C2013	0316 9190	1000 pf, $\pm 20\%$ , 3000V	RMC	3KV
					C2014	0316 4930	0.01 $\mu\text{f}$ , +100 -0%, 2000V	RMC	2KV
					C2015	0327 7500	plastic, 0.15 $\mu\text{f}$ , $\pm 10\%$ , 400V	AMX	C296AC
					C2016	0316 4930	0.01 $\mu\text{f}$ , +100 -0%, 2000V	RMC	2KV
					C2017 (HV and HF Series only)	0326 4620	5000 pf, GMV	ERC	801

# section 6a — parts lists and schematic

Symbol	Part Number	Description	Recommended Vendor Code	Type
C2018 & C2019	0326 4620	5000 pf, GMV	ERC	801
C2020	0327 6910	0.0033 $\mu$ f, $\pm$ 20%, 5000V	CPC	DA045CB
C2021	0326 7820	plastic, 0.022 $\mu$ f, $\pm$ 10%, 200V	AMX	C296AB
C2022	0326 4640	0.01 $\mu$ f, GMV	ERC	811
C2023	0313 4580	0.02 $\mu$ f, +100 -0%	RMC	Plug-in B
C2024	0316 9190	0.001 $\mu$ f, 3KV	RMC	3KV

## SEMICONDUCTORS

CR1001 to CR1003	2600 9220	diode, silicon, 1N4384	GEN	FCI
CR1004	2600 6910	diode, FD841	FCI	EIA
CR1006	2600 9240	diode, 1N980A	EIA	
CR1101 & CR1102	2600 9220	diode, silicon, 1N4384	GEN	FCI
CR1104	2600 6910	diode, FD841	FCI	
CR1201 & CR1202	2600 9220	diode, silicon, 1N4384	GEN	FCI
CR1204	2600 6910	diode, FD841	FCI	
CR1301 & CR1302	2600 9220	diode, silicon, 1N4384	GEN	EIA
CR1304	2600 9230	diode, 1N823	EIA	
CR2000	2600 9220	diode, silicon, 1N4384	GEN	ABD
CR2001	2600 2711	rectifier, metallic	ABD	
CR2002	2600 9220	diode, silicon, 1N4384	GEN	FCI
CR2003	2600 8020	diode, FDG 3091	FCI	
CR2050 & CR2051 (HV and HF Series only)	2600 3031	rectifier, metallic	ABD	
CR2052	2600 3031	rectifier, metallic	ABD	

## LAMPS

DS1401	1201 1280	incandescent, 6.3V	GE	
E1401 & E1402	1200 1310	incandescent, bayonet, # 47	GE	
E2001	1200 3960	glow, NEV	GE	

## FUSES

F101	1100 5210	3 amperes, slo-blo	LFI	313003
F102	1100 0740	0.5 ampere	LFI	312.500
F110	1100 0760	1 ampere	LFI	312001
F120	1100 0770	1.5 amperes	LFI	31201.5
F130	1100 0760	1 ampere	LFI	312001
F150 ("M" Models only)	1100 5280	2 amperes, slo-blo	LFI	313002

## HEATER ELEMENTS

HR1501 to HR1506 ("M" Models only)	6900 2511	heater strip	ABD	
---------------------------------------	-----------	--------------	-----	--

## HYBRID COILS

HY1003 to HY1008 (Types 765 & 767 Series only)	2110 1590	bead, ferroxcube	FER	
HY1301 (Types 765 & 767 Series only)	2110 1560	bead, ferroxcube	FER	

Symbol	Part Number	Description	Recommended Vendor Code	Type
--------	-------------	-------------	-------------------------	------

## ELECTRICAL CONNECTORS

J1001 (Portable Models only)	0905 9320	receptacle, round, 3 contacts	GE	BRI-4
J1001 (Bench and Rack Models only)	0905 8440	receptacle, round, 3 contacts	GE	BRI-4
J1005	0904 4381	jack, tip, black (1V P-P)	ABD	
J2001 (Bench and Rack Models only)	0905 7610	receptacle, BNC, rf, female, 1 contact		UG 625-A/U
J8001 & J9001	0905 7360	receptacle, general purpose, female, 32 contacts	APH	26 190 32
P2001 (Bench and Rack Models only)	0905 9150	cover, electrical, BNC	DAG	

## LV SERIES

P2002 (Bench Model only)	0904 4211	HV connector assembly	ABD	
P2002 (Portable and Rack Models only)	0904 4212	HV connector assembly	ABD	

## HV AND LV SERIES

P2002 (Bench Model only)	0904 4311	HV connector assembly	ABD	
P2002 (Portable and Rack Models only)	0904 4312	HV connector assembly	ABD	

## COIL

L2001	2101 8441	Beam Rotate	ABD	
-------	-----------	-------------	-----	--

## TRANSISTORS

Q1001 & Q1002	2600 7280	DU # 6B alternate, 2N1893	FCI	
Q1003	2600 9170	DU # 51A alternate, 2N3442	SIL	
Q1051	2600 7210	DU # 5 alternate, 2N697	FCI	
Q1101 & Q1102	2600 7280	DU # 6B alternate, 2N1893	FCI	
Q1103	2600 9170	DU # 51A alternate, 2N3442	SIL	
Q1201 & Q1202	2600 7280	DU # 6B alternate, 2N1893	FCI	
Q1203	2600 9170	DU # 51A alternate, 2N3442	SIL	
Q1301 to Q1303	2600 7280	DU # 6B alternate, 2N1893	FCI	
Q1304	2600 9170	DU # 51A alternate, 2N3442	SIL	
Q2000 & Q2001	2600 9200	2N3390	GE	
Q2002	2600 7280	DU # 6B alternate, 2N1893	FCI	
Q2003	2600 9170	DU # 51A alternate, 2N3442	FCI	



# parts lists and schematics – section 6a

			Recommended Vendor					Recommended Vendor	
Symbol	Part Number	Description	Code	Type	Symbol	Part Number	Description	Code	Type
<b>RESISTORS</b>									
Note: All resistors are fixed, film, $\pm 5\%$ , and $\frac{1}{2}W$ unless otherwise specified, K = thousand, M = million.									
R1001	0234 9420	36K, 1W	CGW	C32	R2000	0203 2070	composition, 330K, $\pm 10\%$	ALB	EB
R1002	0234 8490	15K	CGW	C20	R2001	0234 8530	22K	CGW	C20
R1003	0234 8040	200	CGW	C20	R2002	0234 8610	47K	CGW	C20
R1004	0234 8110	390	CGW	C20	R2003	0234 8540	24K	CGW	C20
R1005	0237 9630	17.8K, $\pm 1\%$ , 1W	CGW	C6	R2004	0234 8580	36K	CGW	C20
R1006	0234 8040	200	CGW	C20	R2005	0203 1860	composition, 5.6K, $\pm 10\%$	ALB	EB
R1007	0234 8690	100K	CGW	C20	R2006	0234 8310	2.7K	CGW	C20
R1008	0234 8040	200	CGW	C20	R2007	0203 2700	composition, 3M, $\pm 10\%$	ALB	EB
R1009	0237 0460	30, 2W	CGW	C42S	R2008	0234 8520	20K	CGW	C20
R1011	0237 9470	12.1K, $\pm 1\%$ , 1W	CGW	C6	R2009 F/R	0109 1910	variable, composition, 500K/ 100K, $\pm 20\%$ (PATTERN CORR/HV ADJ)	CTS CGW	2-45 C20
R1012	0109 1760	variable, wire wound, 1K, $\pm 10\%$ (+200V ADJ)	CTS	AW	R2010	0234 8620	51K	ALB	EB
R1013	0237 9470	12.1K, $\pm 1\%$ , 1W	CGW	C6	R2011	0203 1160	composition, 680K	ALB	EB
R1014	0203 1180	composition, 820K	ALB	EB	R2012 &				
R1051	0234 8490	15K	CGW	C20	R2013	0203 7240	composition, 1.5M, 2W	CLS	37
R1052	0236 7380	59K, $\pm 1\%$	CGW	NS20	R2014	0108 0750	variable, composition, 2.5M, $\pm 20\%$ (FOCUS)	ALB	EB
R1053	0236 6810	15K, $\pm 1\%$	CGW	NS20	R2015	0203 1040	composition, 220K	CLS	53C
R1054	0236 5560	750, $\pm 1\%$	CGW	NS20	R2016	0109 2300	variable, composition, 500K, $\pm 20\%$ , 1W (INTENSITY)	ALB	EB
<b>R1055 &amp; R1056</b>									
(Types 766H and 766MH Series only)									
	0107 2631	variable, composition, 30K, $\pm 20\%$ (Position)	ABD		R2017	0203 0850	composition, 36K	ALB	EB
R1101	0234 8530	22K	CGW	C20	R2018	0235 5400	2M, $\frac{1}{4}W$	ALB	CB
R1102	0234 8590	39K	CGW	C20	R2019	0203 2150	composition, 1.5M, $\pm 10\%$	ALB	EB
R1103	0234 8040	200	CGW	C20	R2020	0203 1380	composition, 5.6M	ALB	EB
R1104	0234 8110	390	CGW	C20	R2021	0203 2170	composition, 2.2M, $\pm 10\%$	ALB	EB
R1105	0237 9470	12.1K, $\pm 1\%$ , 1W	CGW	C6	R2022	0107 2731	variable, 20K/20K/500K (BEAM ROTATE)	ABD	
R1106	0234 8040	200	CGW	C20	<b>R2023 (Bench and Rack Models only)</b>				
R1107	0234 8690	100K	CGW	C20	0203 2130	composition, 1M, $\pm 10\%$	ALB	EB	
R1108	0234 8040	200	CGW	C20	R2024	0235 5400	2M, $\frac{1}{4}W$	ALB	CB
R1109	0234 1340	5, 3W	WDL	3X	R2025	0237 5970	composition, 5.1	ALB	EB
R1111	0237 9110	5.11K, $\pm 1\%$ , 1W	CGW	C6	R2026	0203 6120	composition, 33, 2W	ALB	HB
R1112	0109 1760	variable, wire wound, 1K, $\pm 10\%$ (+100V ADJ)	CTS	AW	R2027 &				
R1113	0237 9110	5.11K, $\pm 1\%$ , 1W	CGW	C6	R2028	0234 8690	100K	CGW	C20
R1201	0234 8490	15K	CGW	C20	R2029	0234 8490	15K	CGW	C20
R1202	0234 9290	10K, 1W	CGW	C32	R2031	0234 8580	36K	CGW	C20
R1203	0234 8510	18K	CGW	C20	R2032	0234 8520	20K	CGW	C20
R1204	0234 8040	200	CGW	C20	<b>R2034 (HV and HF Series only)</b>				
R1205	0237 9470	12.1K, $\pm 1\%$ , 1W	CGW	C6	0236 3170	composition, 430K	CGW	C20	
R1206	0234 8110	390	CGW	C20	<b>R2035 (HV and HF Series only)</b>				
R1207	0234 7990	120	CGW	C20	0203 2130	composition, 1M, $\pm 10\%$	ALB	EB	
R1208	0234 8690	100K	CGW	C20	R2036	0203 3610	composition, 3.6K, 1W	ALB	
R1209	0234 8040	200	CGW	C20	<b>SWITCHES</b>				
R1211	0233 5400	wire wound, 5, 7W	DAL	R57	S101	0503 2480	slide, DPDT (115V/230V)	MUT	4633
R1212	0237 9110	5.11K, $\pm 1\%$ , 1W	CGW	C6	S102 (part of				
R1213	0109 1760	variable, wire wound, 1K, $\pm 10\%$ (+50V ADJ)	CTS	AW	R1403)	0107 2343	(POWER)		
R1214	0237 9110	5.11K, $\pm 1\%$ , 1W	CGW	C6	S103	2800 3050	thermostatic (THERMAL CUTOUT)	KXM	MC10-5
R1301	0234 8530	22K	CGW	C20	<b>S150 ("M" Models only)</b>				
R1302	0237 8190	562, $\pm 1\%$ , 1W	CGW	C6	0503 2400	thermostatic	ELM	2200-1	
R1303	0109 1760	variable, wire wound, 1K, $\pm 10\%$ (-50V ADJ)	CTS	AW	S210	0503 2460	slide, 3PDT (NORMAL/SINGLE)	COW	
R1304	0237 9110	5.11K, $\pm 1\%$ , 1W	CGW	C6	<b>TRANSFORMERS</b>				
R1305	0234 8210	1K	CGW	C20	T1001	2001 4851	power	ABD	
R1306 &					T2001	2001 4821	high-voltage	ABD	
R1307	0234 8040	200	CGW	C20	<b>TEST POINTS</b>				
R1308	0237 9110	5.11K, $\pm 1\%$ , 1W	CGW	C6	TP1001	0905 8450	jack, tip, red (+200V)	EFJ	Series 105
R1309	0234 8040	200	CGW	C20	TP1101	0905 8450	jack, tip, red (+100V)	EFJ	Series 105
R1311	0237 9110	5.11K, $\pm 1\%$ , 1W	CGW	C6	TP1201	0905 8450	jack, tip, red (+50V)	EFJ	Series 105
R1312	0237 9630	17.8K, $\pm 1\%$ , 1K	CGW	C6	TP1301	0905 8450	jack, tip, red (-50V)	EFJ	Series 105
R1313	0234 8110	390	CGW	C20					
R1314	0234 8040	200	CGW	C20					
R1316	0234 7990	120	CGW	C20					
R1317	0234 8690	100K	CGW	C20					
R1318	0222 4550	wire wound, 5, 5W	WDL	5X					
R1401 &									
R1402	0234 8010	150	CGW	C20					
R1403	0107 2343	variable, wire wound, 50, $\pm 10\%$ (SCALE ILLUM)	ABD						

# section 6a — parts lists and schematics

Symbol	Part Number	Description	Recommended Vendor	
			Code	Type

## CATHODE-RAY TUBES

### Low-Voltage Series

V204	2501 0551*	F7650-O-P1 (MET)	ABD
	2501 0552*	F7650-O-P2/G (MET)	ABD
	2501 0553*	F7650-O-P2/B (MET)	ABD
	2501 0554*	F7650-O-P7 (MET)	ABD
	2501 0555*	F7650-O-P11 (MET)	ABD
	2501 0556*	F7650-O-P31 (MET)	ABD

### High-Voltage Series

2501 0561*	F7660-O-P1 (MET)	ABD
2501 0562*	F7660-O-P2/G (MET)	ABD
2501 0563*	F7660-O-P2/B (MET)	ABD
2501 0564*	F7660-O-P7 (MET)	ABD
2501 0565*	F7660-O-P11 (MET)	ABD
2501 0566*	F7660-O-P31 (MET)	ABD

### High-Frequency Series

2501 0681*	F7670-O-P1 (MET)	ABD
2501 0682*	F7670-O-P2/G (MET)	ABD
2501 0683*	F7670-O-P2/B (MET)	ABD
2501 0684*	F7670-O-P7 (MET)	ABD
2501 0685*	F7670-O-P11 (MET)	ABD
2501 0686*	F7670-O-P31 (MET)	ABD

\* Depending on sales order

## CABLE & WIRES

W2051	5028 9061	300-ohm cable termination
—	5028 6900	6" # 24 stranded wire (black)
—	5028 6930	7" # 24 stranded wire (orange)
—	5028 6960	8" # 24 stranded wire (blue)

## CLAMP ASSEMBLY

—	3701 3241	clamp
—	6009 6180	screw, MSBH, 6-32 x 1/2
—	6200 3670	washer, flat, # 6
—	6210 0030	washer, lock, # 6

Symbol	Part Number	Description	Recommended Vendor	
			Code	Type

## CABLE

W1001	5030 2640	assembly	MIL
-------	-----------	----------	-----

## TYPE 7062 CRT TERMINATION NETWORK (High-Frequency Series Only)

Symbol	Part Number	Description
C2051 &		
C2052	0319 7450	Capacitor, fixed, ceramic, 15 pf, $\pm 1\%$ , 500V
C2053	0319 1253	Capacitor, variable, 0.65-3.2 pf, 350V
C2054 &		
C2056	0319 2420	Capacitor, fixed, composition, 1.5 pf, $\pm 5\%$ , 500V
C2057	0319 1050	Capacitor, fixed, ceramic, 0.02 $\mu$ f, +60 -40%, 150V
CR2051 to		
CR2056	2600 8670	Diode, 1N3062
L2051 &		
L2052	2101 9441	Coil, termination, 9 turns, # 27 wire
L2053 &		
L2054	2101 9451	Coil, inductance, 4 turns, # 27 wire
Q2050 &		
Q2051	2600 8410	Transistor, DU # 28A
	2600 8390	alternate transistor, 2N3013

## RESISTORS

Note: All resistors are fixed, film,  $\pm 5\%$ , and  $\frac{1}{2}W$  unless otherwise specified, K = thousand, M = million.

R2051	0237 5680	20.5K, $\pm 1\%$ , 1/8W
R2052 &		
R2053	0234 8340	3.6K
R2054	0237 5680	20.5K, $\pm 1\%$ , 1/8W
R2055	0235 6210	composition, 1M, $\pm 10\%$ , 1/4W
R2056	0237 5700	38.3K, $\pm 1\%$ , 1/8W
R2057 to		
R2059	0237 6420	300, 2W
R2061	0237 6420	300, 2W
R2062 &		
R2063	0234 7900	51
R2064	0234 8610	47K
R2065	0109 3580	variable, composition, 10K, 0.1W (PEAK ADJ)
R2066	0235 6210	composition, 1M, $\pm 10\%$ , 1/4W

# SECTION 6B

## SPARE PARTS LIST

### SPARE PARTS REQUIREMENTS

#### a. General

The Types 765, 766 & 767 Transistorized Oscilloscopes are extremely reliable and dependable instruments. Only components thoroughly tested and approved by the engineers of the Quality Assurance Department are used in this instrument. Continued performance tests, environmental and life testing of production units make certain your instrument will give many years of satisfactory service. These new Fairchild instruments are precision-engineered and require no selected parts.

Two lists of "running spares" are included to aid you in periodic maintenance. The running-spare parts lists include recommended quantities and reference symbol numbers. Section 6A of this Instruction Manual gives a complete listing of all components and their recommended vendors so that you may readily procure them from a local supply house or your own stores.

*Note:* The local Fairchild Field Engineering representative and his service organization can assist you in obtaining any additional components in the shortest possible time. To help expedite service, always give the Type Number and Serial Number of the instrument; always specify the part number and give a description of the component (see Section 6A of this manual).

#### b. 500-Hour Spares (6 months)

The recommended list for one through three units is given below.

#### FUSES

Symbol	Quantity
F101	1
F102	1
F110	1
F120	1
F150 ("M" Models only)	1

#### CATHODE-RAY TUBES

For Type 766 LV Series	F7650-O-P2/B
For Type 766 HV Series	F7660-O-P2/G
For Type 766 HF Series	F7670-O-P2/G

#### TRANSISTORS

Symbol	Quantity
Q1001 (DU # 6B)	3
Q1003 (DU # 51A)	2
Q1051 (DU # 5)	1
Q2000 (2N3390)	1
Q2002 (DU # 10)	1

#### DIODES

CR1001 (1N4384)	4
CR1004 (FD841)	1
CR1006 (1N980A)	1
CR1304 (1N823)	1
CR2001 (MET)	1
C2003 (FD63091)	1
CR2052 (MET)	1

#### LAMPS

DS1401	1
E1401	1
E2001	1

#### c. 2000-Hour Spares (2 years)

The recommended list for one through ten units is given below. Maintain spares indicated plus one for each oscilloscope in use; 2 of each set of the 500-hour spare list given in paragraph (b) plus the quantities listed as follows:

#### CAPACITORS

Symbol	Quantity	Symbol	Quantity
C1001	1	C1303	1
C1003	1	C2003	1
C1004	1	C2004	1
C1006	2	C2005	1
C1007	1	C2008	2
C1008	1	C2010	1
C1009	1	C2013	1
C1031	1	C2015	1
C1101	1	C2020	1
S1201	1	C2022	1
C1302	1	C2024	1

#### ELECTRICAL CONNECTORS

Symbol	Quantity
J1001 (Portable Models only)	1
J1001 (Bench and Rack Models only)	1
J1005	1
J2001 (Bench and Rack Models only)	1
J8001	1
P2001 (Bench and Rack Models only)	1
P2002 (Bench Model only)	1
P2002 (Portable and Rack Models only)	1

#### HEATER ELEMENTS

("M" Series Only)

Symbol	Quantity
HR1501	2

#### HYBRID COILS

(Types 765 & 767 Series Only)

HY1003	2
HY1301	2

## section 6b – spare parts list and schematics

### RESISTORS

Symbol	Quantity	Symbol	Quantity
R1001	1	R2002	1
R1002	1	R2004	1
R1003	4	R2005	1
R1004	1	R2006	1
R1005	1	R2007	1
R1007	2	R2008	1
R1009	1	R2009 F/R	1
R1011	1	R2011	1
R1012	1	R2012	1
R1014	1	R2014	1
R1052	1	R2015	1
R1053	1	R2016	1
R1054	1	R2017	1
R1055 (766H & 766MH Series only)	1	R2018	1
R1101	1	R2019	1
R1102	1	R2020	1
R1109	1	R2021	1
R1111	2	R2022	1
R1202	1	R2023 (Bench & Rack Models only)	1
R1203	1	R2024	1
R1207	1	R2025	1
R1211	1	R2026	1
R1302	1	R2031	1
R1305	1	R2034 (HV & HF Series only)	1
R1318	1	R2035 (HV & HF Series only)	1
R1401	1	R2036	1
R1403	1		
R2000	1		

### SWITCHES

Stock only one each of the following switches for each ten units being maintained:

S101, S102, S103, S150 ("M" Models only), and S210

### TRANSFORMERS AND COIL

Symbol	Quantity
L2001	1
T1001	1
T2001	1

### TEST POINT JACKS

TP1001	1
--------	---

#### d. Miscellaneous

The following items may be stocked in quantities of one for each ten units being maintained:

Name	Part Number
Adapter	0905 9000
Bezel, front	3506 2001
Bushing	4301 2100
Cushion, bezel, front	3801 8442
Fuseholder	1100 1890
Knob, small (Intensity, Focus and Scale Illum Controls)	4501 2022
Knob, small (Astig)	4501 2023
Lampholder	1200 5430
Nut, knurled	6103 4141
Pilot light (red)	1201 2010
Scale, illuminated	4501 0451
Transistor Cover	4202 3001

#### e. Summary

The quantities of spare parts given in the preceding paragraphs are intended for industrial and military duty under normal environment and heavy-use conditions. It is suggested that the maintenance engineer evaluate:

1. The conditions under which the instruments will be used.
2. The skill of the maintenance technicians.
3. Other similar items on hand.
4. The effect of procurement time of spares and effects of instrument down-time on your organization.

It is recommended that inventories of spare parts outlined above be adjusted accordingly to the requirements of your own laboratory or plant.

In the first analysis, the factory recommends the availability of spares or standby equipments since extensive life testing of your instrument has shown no higher failure rate for any specific component.

## LIST OF RECOMMENDED VENDORS

CODE	NAME	CODE	NAME
ABD	Du Mont Laboratories	HON	Honeywell
AER	Aerovox Corporation	HOP	Hopkins Engineering Company
AHH	Arrow-Hart & Hegeman Electric Company	HP	Hewlett-Packard Company
ALB	Allen-Bradley Company	IEC	International Electronics Corporation
ALC	Allied Control	IRC	International Resistance Company
ALCO	Alco Electronic Products	IRP	International Rectifier Corporation
ALD	Alden Products Company	ITT	ITT Components Division
AMA	Amaton Electronic Hardware	JEF	Jeffers Electronics, Inc.
AMP	Amp Inc.	JHN	E. F. Johnson Company
AMR	Amperite Company, Inc.	JWM	J. W. Miller Company
AMX	Amperex Electronics Products, Inc.	KUL	Kulka Electric Mfg. Co. Inc.
APC	American Phenolic Corporation	KXM	Klixon Metals and Control Corporation
APH	Amphenol Electronics Corporation	LED	Ledex Inc.
ARC	Arco Electronics Inc. (Elmenco)	LEE	Leecraft Mfg. Company
AST	Astron Corporation	LFI	Littlefuse, Inc.
AUT	Automatic Metal Products Corporation	LIN	Line Electric
BEL	Belfuse	MAL	P. R. Mallory & Company, Inc.
BNS	Bourns Inc.	MCR	Micro Switch (Division of Minneapolis-Honeywell Regulator Co.)
BUR	Burndy Engrg. Company	MIC	Micamold Electronics Mfg. Corporation
BUS	Bussmann Mfg. Company	MIL	Miller Electric Company
CAN	Cannon Electric Company	MOT	Motorola Semiconductor Products, Inc.
CBS	CBS-Hytron Division of CBS	MOY	M-O Valve Company Ltd.
CDE	Cornell-Dubilier Electric Corporation	MUC	Mucon Corporation
CGW	Corning Glass Works	MUT	The Muter Company
CH	Cutler-Hammer, Inc.	NYT	New York Transformer Company, Inc.
CHC	Chester Cable Corporation	OAK	Oak Mfg. Company
CHM	Chatham Electronics	PHC	Philco Corporation
CIN	Cinch Manufacturing Company	PHI	Philips Electronic Tube Division
CLS	Clarostat Mfg. Co., Inc.	PLS	Plastoid Corporation
COC	Continental Carbon	POT	Potter & Brumfield, Inc.
COM	Comar Electric	PRC	Precision Resistor Co., Inc.
COW	Continental-Wirt Electronics Corporation	PYR	Pyramid Electric Company
CPC	C. P. Clare & Company	RCA	Radio Corporation of America
CRL	Centralab, Division of Globe-Union, Inc.	RMC	Radio Materials Corporation
CST	Chicago Standard Transformer Corporation	ROY	Royal Electric Corporation, Inc.
CTC	Cambridge Thermionic Corporation	RTN	Rotron Mfg. Company
CTS	Chicago Telephone Supply Corporation	SIG	Signalite Inc.
DAG	Dage Electric Company, Inc.	SIL	Silicon Transistor Corporation
DAL	Dale Products, Inc.	SLT	Sealectro Corporation
DLC	Dialight Corporation	SOL	Solitron Devices, Inc.
DRK	Drake Mfg. Company	SPG	Sprague Electric Company
EBY	Hugh H. Eby, Inc.	STC	Stackpole Carbon Company
EDL	Edal Industries	STW	Standard Winding Company
EIA	Any manufacturer meeting EIA standards	SUM	Summit Coil Company
ELC	Electra Manufacturing Company	SWW	Stanwyck Winding Company
ELD	Eldema Corporation	SYL	Sylvania Electric Products, Inc.
EMC	Electro Motive Mfg. Company	SYN	Syntronic Instruments, Inc.
EMW	Elmwood Sensors, Inc.	TEC	Transistor Electronics Corporation
ERC	Erie Resistor Corporation	TEX	Texas Instruments, Inc.
ESX	Essex Electronics	THC	Thermal Control, Inc.
FAST	John E. Fast Company	TOR	Torrington Mfg., Company
FCI	Fairchild Camera and Instrument Corporation	TRS	Tresco, Inc.
FER	Ferroxcube Corporation of America	TRU	Tru-Ohm Products
GDE	Good-All Electric Mfg. Company	TUG	Tung-Sol Electric Inc.
GE	General Electric Company	UCN	Ucinite Company
GEN	General Instrument Corporation	UTC	United Transformer Company
GEP	General Products Corporation	VIC	The Victoreen Instrument Company
GLB	Globe Industries	WDE	Wood Electric Corporation
GRC	General Radio Company	WDL	Ward Leonard Electric Company
GRY	Grayhill, Inc.	WES	Weston Electrical Instrument Corporation
GUD	The Gudeman Company	WYN	Welwyn International Inc.
HAM	The Hammarlund Manufacturing Co., Inc.		

# INSTRUMENT WARRANTY AND SERVICE NOTICE

## WARRANTY

The Instrumentation Division warrants that each new Cathode-ray Oscilloscope, Automotive Test Equipment, and other Electronic or Electrical Test or Measuring Equipment (hereinafter referred to as "Instrument") manufactured or sold by it, is free from defects in material or workmanship under normal use and service for a period of one year from the date of its sale to the first purchaser for use. If, upon examination by Fairchild, the Instrument is determined to be defective in workmanship or material, Fairchild will, subject to the conditions set forth below, either repair the defective part or replace it with a new part. Fairchild shall not be liable for any delay or failure to furnish a replacement part resulting directly or indirectly from any governmental restriction, priority or allocation or any other governmental regulatory order or action, nor shall Fairchild be liable for damages by reason of the failure of the Instrument to perform properly or for any consequential damages. This warranty does not apply to any Instrument that has been subject to negligence, accident, misuse or improper installation or operation or that in any way has been tampered with, altered or repaired by any person other than an authorized Fairchild service organization or an employee thereof, or to any Instrument whose serial number has been altered, defaced or removed, or to any Instrument purchased within, and thereafter removed beyond, the continental limits of the United States.

This warranty shall, at Fairchild's option, become void unless registration thereof is promptly effected as provided below. This warranty is in lieu of all other warranties, expressed or implied, and no one is authorized to assume any liability on behalf of Fairchild or impose any obligation upon it in connection with the sale of any Instrument, other than as stated above.

## REGISTERING THE WARRANTY

To register this warranty, the enclosed warranty registration card must be properly filled out and mailed to the Instrument Service Department immediately upon receipt of the equipment. Complete information is necessary. **BOTH THE TYPE NUMBER AND THE SERIAL NUMBER OF THE INSTRUMENT MUST BE GIVEN ON THIS CARD.** Instruments must be examined immediately upon receipt, since claims for damage in transit will not be honored by the carrier unless prompt action is taken.

## CHANGES IN SPECIFICATIONS

The right is reserved to change the published specifications of equipment at any time and to furnish merchandise in accordance with current specifications without incurring any liability to modify equipment previously sold, or to supply new equipment in accordance with earlier specifications excepting under the classification of special apparatus.

## SERVICE

In order to insure service under our warranty, the enclosed warranty service card must be properly filled out and returned to the factory. In all cases where service or adjustment is requested, please first contact the factory or authorized depot, giving complete information concerning the nature of the failure and describing the manner in which the equipment was used when failure occurred. **THE TYPE NUMBER AND SERIAL NUMBER** of the equipment must also be given. In this way, much time can be saved and unnecessary inconvenience often avoided. When writing to the factory in this respect, address:

**Fairchild Camera and Instrument Corp.**

**Instrumentation Division**

**50 Somerset Place, Clifton, New Jersey**

The Instrument Service Department will then send to the customer the written procedure for disposition and shipping instructions. All equipment should be packed and shipped in accordance with this procedure; and identification tags should be attached to each tube or instrument.

## REPLACEMENT PARTS

If it is necessary to order a replacement component from the factory, always give the Type number and Serial number of the Instrument. Before ordering parts for in-warranty replacement or purchasing them for out-of-warranty replacement, be sure to consult the Parts List in the Instruction Manual. The Parts List gives the values, tolerances, ratings, and Fairchild part number for all electrical components used in the Instrument. This will help to expedite service.

## PATENT NOTICE

Manufactured under one or more U. S. Patents owned or controlled by Fairchild Camera and Instrument Corporation, 50 Somerset Place, Clifton, New Jersey, U.S.A. Patent Numbers supplied upon request.

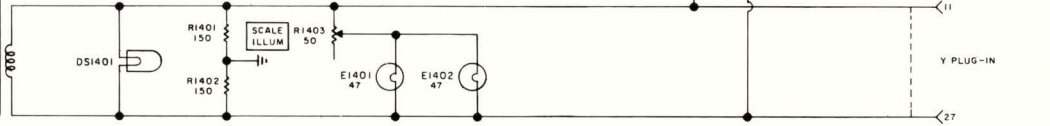
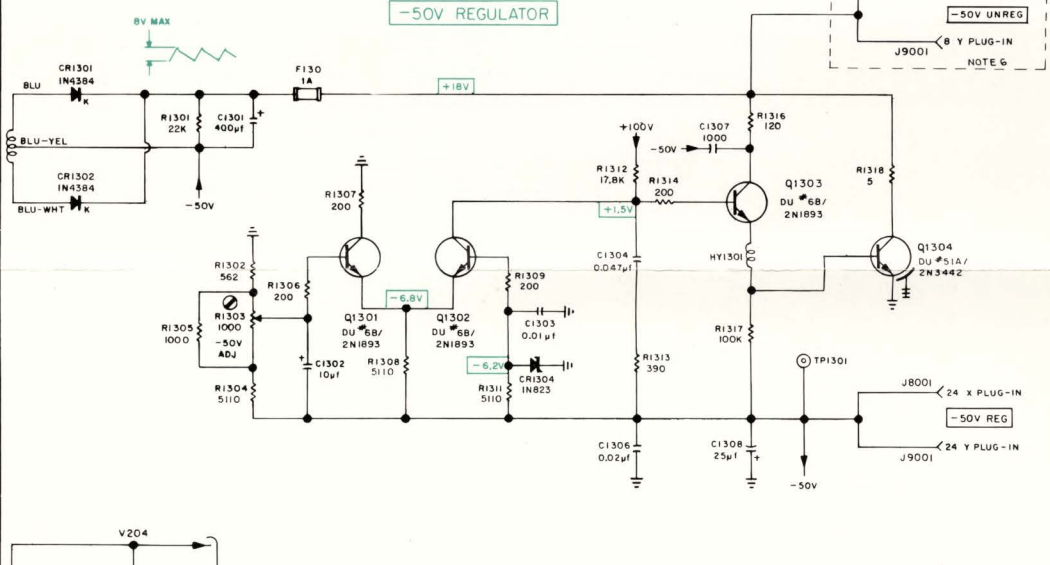
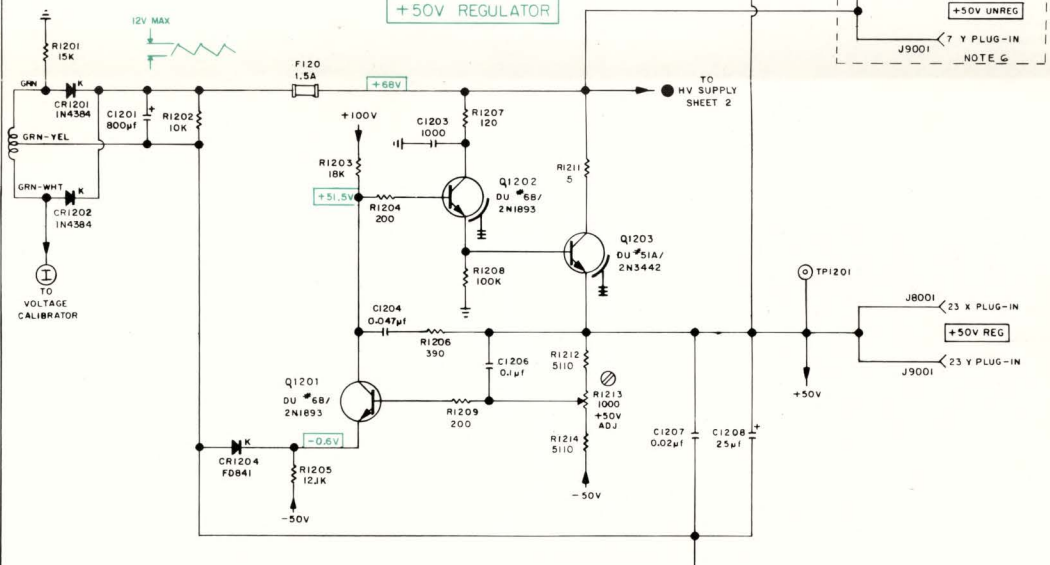
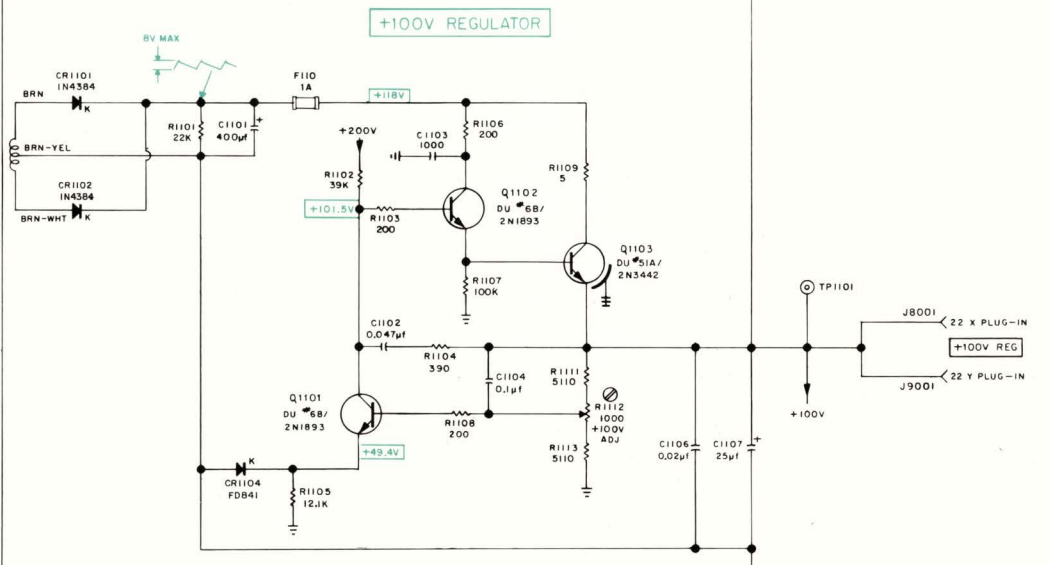
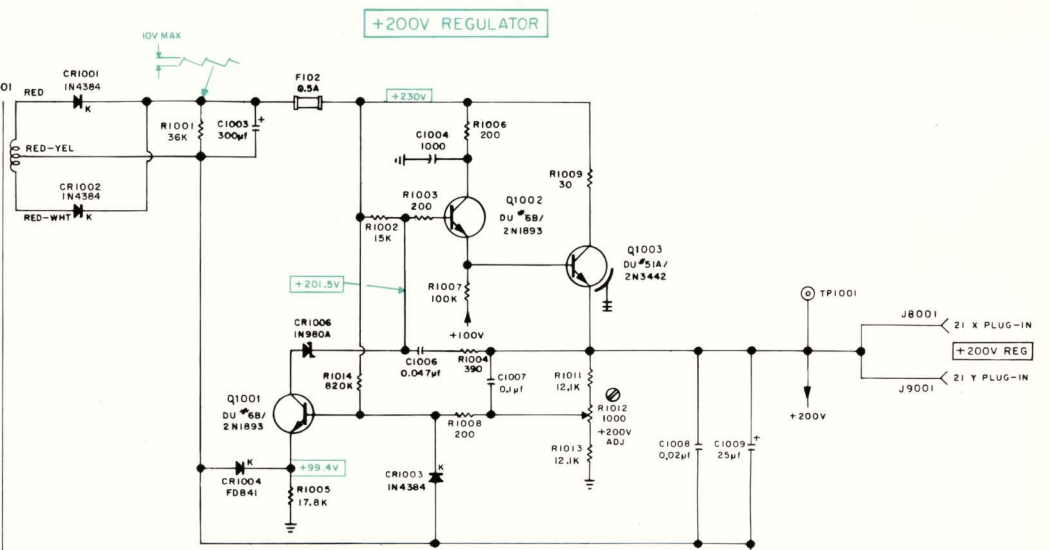
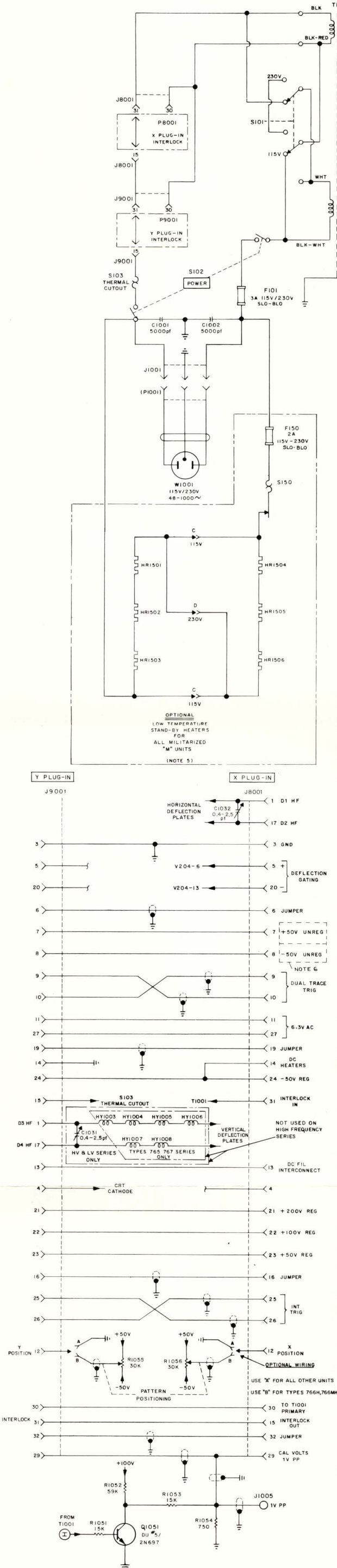

**NOTES:**

1. RESISTANCE VALUES ARE IN OHMS, K=THOUSAND, M=MILLION.
2. CAPACITANCE VALUES ARE IN  $\mu$ F UNLESS OTHERWISE SPECIFIED.
3. SERVICE ADJUSTMENT.
4. HEAT SINK.
5. WHEN THE 115V/230V SELECTOR SWITCH (S101) IS SET FOR 115V OPERATION, HEATER MUST BE WIRED PER OPTION "C", FOR 230V OPERATION, OPTION "D".
6. NOT REQUIRED IN LATER PRODUCTION UNITS.

**VOLTAGE DATA**  
Measurements taken at mid-line voltage with Types 74-13A and 74-02A Plug-ins

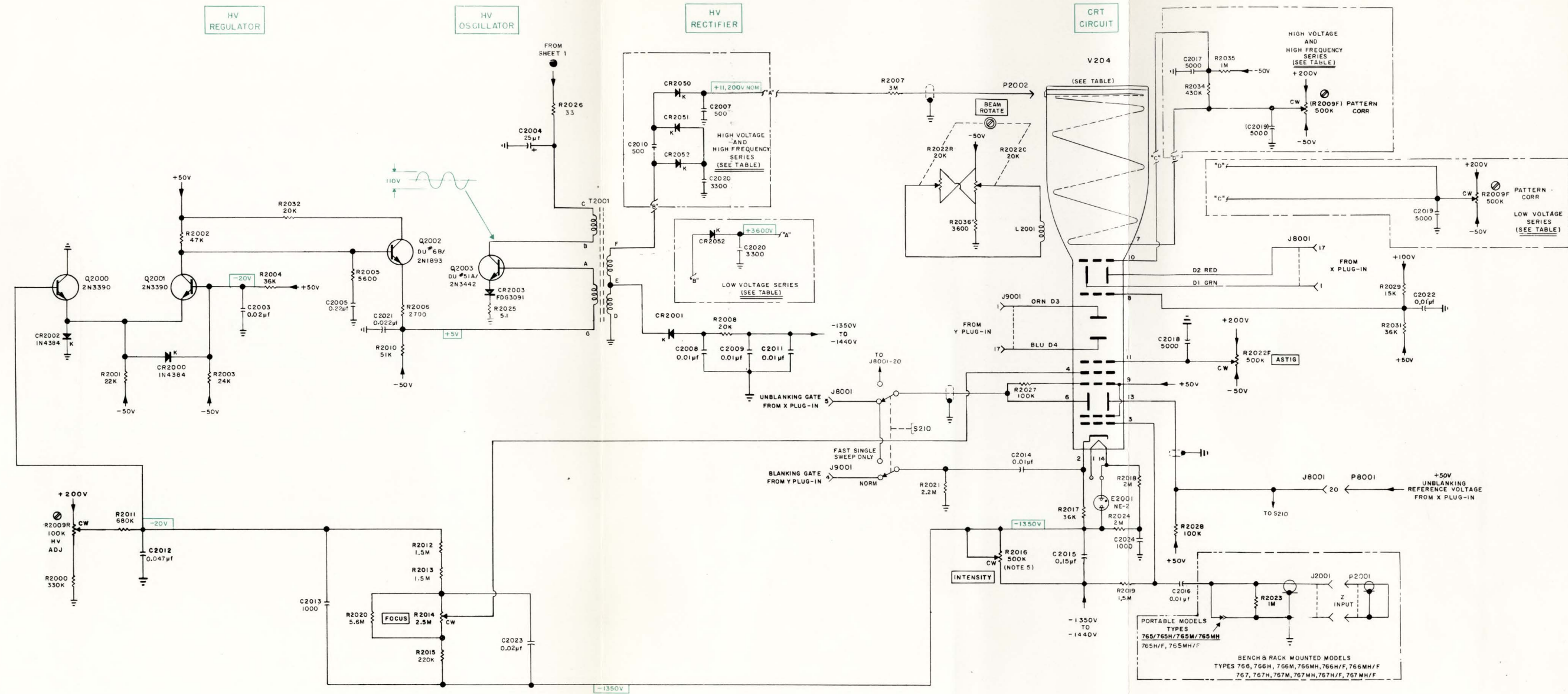

- NOTES
1. RESISTANCE VALUES ARE IN OHMS; K=THOUSAND, M=MILLION.
  2. CAPACITANCE VALUES ARE IN  $\mu$ F UNLESS OTHERWISE SPECIFIED.
  3. SERVICE ADJUSTMENT.
  4. FRONT PANEL SCREWDRIVER ADJUSTMENT.
  5. FOR OPTIMUM SINGLE SWEEP OPERATION, INTENSITY CONTROL, R2016 (500K) SHOULD BE CHANGED TO 1MEG.

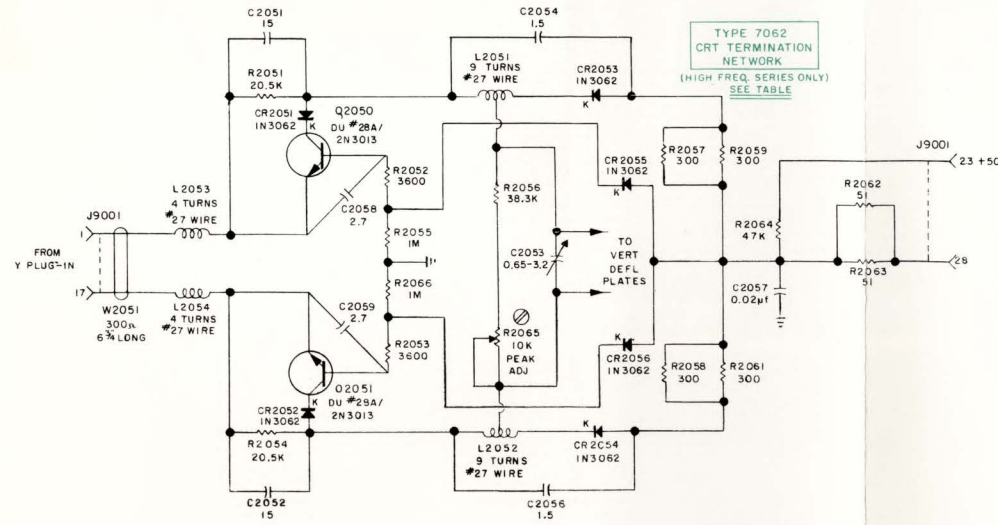

SERIES	TYPES	CRT
LOW VOLTAGE	765, 765M, 766, 766M, 767, 767M	F7650-O-P.
HIGH VOLTAGE	765H, 765MH, 766H, 766MH, 767H, 767MH	F7660-O-P.
HIGH FREQUENCY	765H/F, 765MH/F, 766H/F, 766MH/F, 767H/F, 767MH/F	F7670-O-P.

VOLTAGE DATA  
Measurements taken at mid-line voltage with Types 74-13A and 76-02A Plug-Ins



ADDENDUM  
TO  
TYPE 765-767 INSTRUCTION MANUAL  
Fairchild Part No. 6704 5894

A. INTRODUCTION

This addendum pertains to the equipments having the same or higher Code Numbers than those listed on the back of the title page in the instruction manual.

B. PURPOSE OF ENGINEERING CHANGE

To eliminate parallax errors in measuring the displayed waveform by incorporating into the equipment CRT's with internal graticules.

C. PARTS LIST REVISIONS

Revise the instruction manual Parts List as shown below.

<u>Symbol</u>	<u>Part Number</u>	<u>Description</u>	<u>Recommended Vendor Code</u>	<u>Vendor Type</u>
LOW-VOLTAGE SERIES				
**CHANGE: V204	2501 1031*	F7650-6-P1	FI	
	2501 1032*	F7650-6-P2		
	2501 1033*	F7650-6-P2B		
	2501 1034*	F7650-6-P7		
	2501 1035*	F7650-6-P11		
	2501 1036*	F7650-6-P31		
HIGH-VOLTAGE SERIES				
	2501 1021*	F7660-6-P1		
	2501 1022*	F7660-6-P2G		
	2501 1023*	F7660-6-P2B		
	2501 1024*	F7660-6-P4		
	2501 1025*	F7660-6-P7		
	2501 1026*	F7660-6-P11		
	2501 1027*	F7660-6-P15		
	2501 1028*	F7660-6-P16		
	2501 1029*	F7660-6-P31		
HIGH-FREQUENCY SERIES				
	2501 1041*	F7670-6-P1		
	2501 1042*	F7670-6-P2G		
	2501 1043*	F7670-6-P2B		
	2501 1044*	F7670-6-P7		
	2501 1045*	F7670-6-P11		
	2501 1046*	F7670-6-P31		

\*Depending on Sales Order

\*\*Symbol remains unchanged



6704 8311  
Sheet 1 of 2  
PCN's #32,490 and  
32,491

*SD*  
*2 July 67*

D. SCHEMATIC DIAGRAM REVISIONS

On Sheet 2 of the Schematic Diagram, change the table which describes the different types of CRT available as follows:

SERIES	TYPES	CRT
(No change)	(No change)	F7650-6-P_ F7660-6-P_ F7670-6-P_ _

ADDENDUM

FOR

TYPE 766H SERIES OSCILLOSCOPE

Reference Manual Part Number 6704 5893 and  
Supplement Part Number 6704 4633

A. INTRODUCTION

This addendum pertains to the following type oscilloscopes:

Type 757  
Type 766, 766M, 766H, 766H/F, 766MH, 766MH/F  
Type 767, 767M, 767H, 767H/F, 767MH, 767MH/F.

B. PURPOSE

The color of the power cable was changed to agree with the new color scheme of the equipment.

C. PARTS LIST REVISION

In the Parts List, change W1001 part number as follows:

FROM

<u>Symbol</u>	<u>Part Number</u>	<u>Description</u>	<u>Recommended Vendor</u>
W1001	5030 1390	Assembly	MIL

TO

W1001	5030 2640	Assembly	MIL
-------	-----------	----------	-----

The logo for Fairchild Instrumentation, featuring the word "FAIRCHILD" in a large, bold, sans-serif font, with "INSTRUMENTATION" below it in a smaller, bold, sans-serif font. Below the company name is the text "A DIVISION OF FAIRCHILD CAMERA AND INSTRUMENT CORPORATION". The logo is flanked by two horizontal bars with a diagonal hatched pattern.

6704 8211  
Sheet 1 of 1

PCN #32,458;  
32,459;  
32,539.