

APPLICATION		REVISIONS					
NEXT ASSY	USED ON	APPROVED	DATE	DESCRIPTION			REV
		<i>Lubeck</i>	11-3-81	RELEASE PER PCO 24174			A
<p>INSTALLATION GUIDE</p> <p>NS23M</p> <p>256K BYTE MEMORY</p>							
<p>This document, and all subject matter disclosed herein, are proprietary items to which National Semiconductor Corporation retains the exclusive rights of dissemination, reproduction, manufacture, and sale. This document is submitted in confidence for consideration by the designated recipient or intended using organization alone, unless permission for further disclosure is expressly granted in writing by National Semiconductor Corporation.</p>							
<p><small>"The following information is reprinted by permission of N.S.C. Copyright 1981".</small></p>							
REV							
SHEET							
REVISION STATUS OF SHEETS	REV	A	A	A	A	A	A
	SHEET	1	2	3	4	5	6
		BY <i>PAUL LUBECK</i> DATE <i>11-3-81</i>		TITLE <u>INSTALLATION GUIDE</u>			
		CHK		NS23M 256K BYTE MEMORY			
		APPD <i>Paul Lubeck</i> <i>11-3-81</i>					
		APPD					
National Semiconductor Corporation 2900 Semiconductor Drive, Santa Clara, Calif. 95051		SIZE	DWG NO <u>409103882-001</u>		REV		
		A			A		
SHEET <u>1</u> OF <u>10</u>							

4230008

APPENDIX D

NATIONAL SEMICONDUCTOR NS253M

INSTALLATION GUIDE

TABLE OF CONTENTS

TITLE/MODEL NO.	DRAWING NO.	REV.	PAGE NO.
NS23M 256K Byte Memory Installation Guide	409103882-001	A	D-1
NS23M Schematic	870103882-001	E	D-11

TABLE OF CONTENTS

Chapter	Page
1.1 INTRODUCTION	3
1.2 UNPACKING AND INSPECTION	5
1.3 ADDRESS RANGE SELECTION	5
1.4 BATTERY BACK-UP	9
1.5 INTERNAL/EXTERNAL REFRESH	9
1.6 INSTALLATION	10
2.0 MAINTENANCE	10

TABLES AND FIGURES

Table	Page
1.1 JUMPER DEFINITIONS	3-4
1.2 SWITCH DEFINITIONS	4-5
1.3 BUS TYPE SELECTION	5
1.4 STARTING ADDRESS SELECTION	7
1.5 ADDRESS RANGE SELECTION	8
1.6 I/O SPACE SELECTION	8
1.7 MEMORY SIZE SELECTION	9

Figure	Page
1.1 JUMPER AND SWITCH PLACEMENT	6
1.2 EXTERNAL REFRESH TIMING	10



National Semiconductor Corporation
2900 Semiconductor Drive, Santa Clara, Calif. 95051

SIZE
A

DWG. NO.
409103882-001

A

SCALE _____

SHEET 2 OF _____

**CHAPTER I
INSTALLATION AND MAINTENANCE**

1.1 INTRODUCTION

This section will provide the information necessary to install the NS23M, install or remove any of the options, and maintain the memory. Table 1.1 lists the configuration jumpers and a description of each, Table 1.2 lists the switches and their functions and Figure 1.1 shows the placement of the jumpers and switches.

W1*	I = 200 ns DRAM R = 150 ns DRAM
W2*	I = 150 ns DRAM R = 200 ns DRAM
W3*	I = Test Only R = Standard Configuration
W4*	I = Standard Configuration R = Test Only
W5*	I = 32K DRAM R = 16K or 64K DRAM
W6*	I = 64K DRAM R = 16K or 32K DRAM
W7*	I = 16K DRAM R = 32K or 64K DRAM
W8*	I = Test Only R = Standard Configuration
W9*	I = Standard Configuration R = Test Only
W10	I = Internal Refresh R = External Refresh
W11	I = External Refresh R = Internal Refresh
W12*	I = 16K or 64K DRAM R = 32K DRAM

Table 1.1
Jumper Definition



National Semiconductor Corporation
2900 Semiconductor Drive, Santa Clara, Calif. 95051

SIZE DWG. NO.

A

409103882-001

A

SCALE

SHEET 3 OF

4230007

Table 1.1 (Continued)

W13*	I = 32K DRAM - Upper R = 16K or 32K Lower or 64K DRAM
W14*	I = 32K DRAM - Lower R = 16K, 32K Upper or 64K DRAM
W15	I = 18 Bit Address Bus R = 22 Bit Address Bus
W16	I = External Refresh to MEMSEL R = External Refresh isolated from MEMSEL
W17*	I = 150 ns DRAM R = 200 ns DRAM
W18*	I = 200 ns DRAM R = 150 ns DRAM
W19	I = +5v Battery Back-up R = +5v Standard
W20	I = +5v Standard R = +5v Battery Back-up

* Factory Configuration - Do not Alter!

DIP SWITCH 1

S1-1	Starting Address Select LSB
S1-2	Starting Address Select
S1-3	
S1-4	
S1-5	
S1-6	
S1-7	
S1-8	
S1-9	Starting Address Select MSB
S1-10	2K/4K I/O Space

Table 1.2
Switch Definitions



National Semiconductor Corporation
2900 Semiconductor Drive, Santa Clara, Calif. 95051

SIZE A	DWG. NO. 409103882-001	A
SCALE	SHEET 4	OF

4230007

Table 1.2 (Continued)

DIP SWITCH 2

S2-1	Memory Size LSB
S2-2	Memory Size
S2-3	Memory Size
S2-4	Memory Size MSB

1.2 UNPACKING AND INSPECTION

Follow the steps listed below to unpack and inspect the NS23M memory module:

1. Remove all packing material from shipping container.
2. Remove memory board from its container.
3. Inspect the board for damage, checking for bent parts, damaged IC's, broken wires or connectors, broken switches, etc. If any damage is found, do not attempt to install the memory.

1.3 ADDRESS RANGE SELECTION

The address range is set by assigning a bus type, selecting the proper I/O space, assigning a starting address and memory size. Refer to Table 1.3 for bus type selection, Table 1.4 and 1.5 for starting address selection, Table 1.6 for I/O space selection, and Table 1.7 for memory size selection.

Bus Type	Install/ Remove
18 Bit Address Bus	Install Jumper W15
22 Bit Address Bus	Remove Jumper W15

Table 1.3 Bus Type Selection



National Semiconductor Corporation
2900 Semiconductor Drive, Santa Clara, Calif. 95051

SIZE

DWG. NO.

A

409103882-001

A

SCALE

SHEET 5 OF

4230007

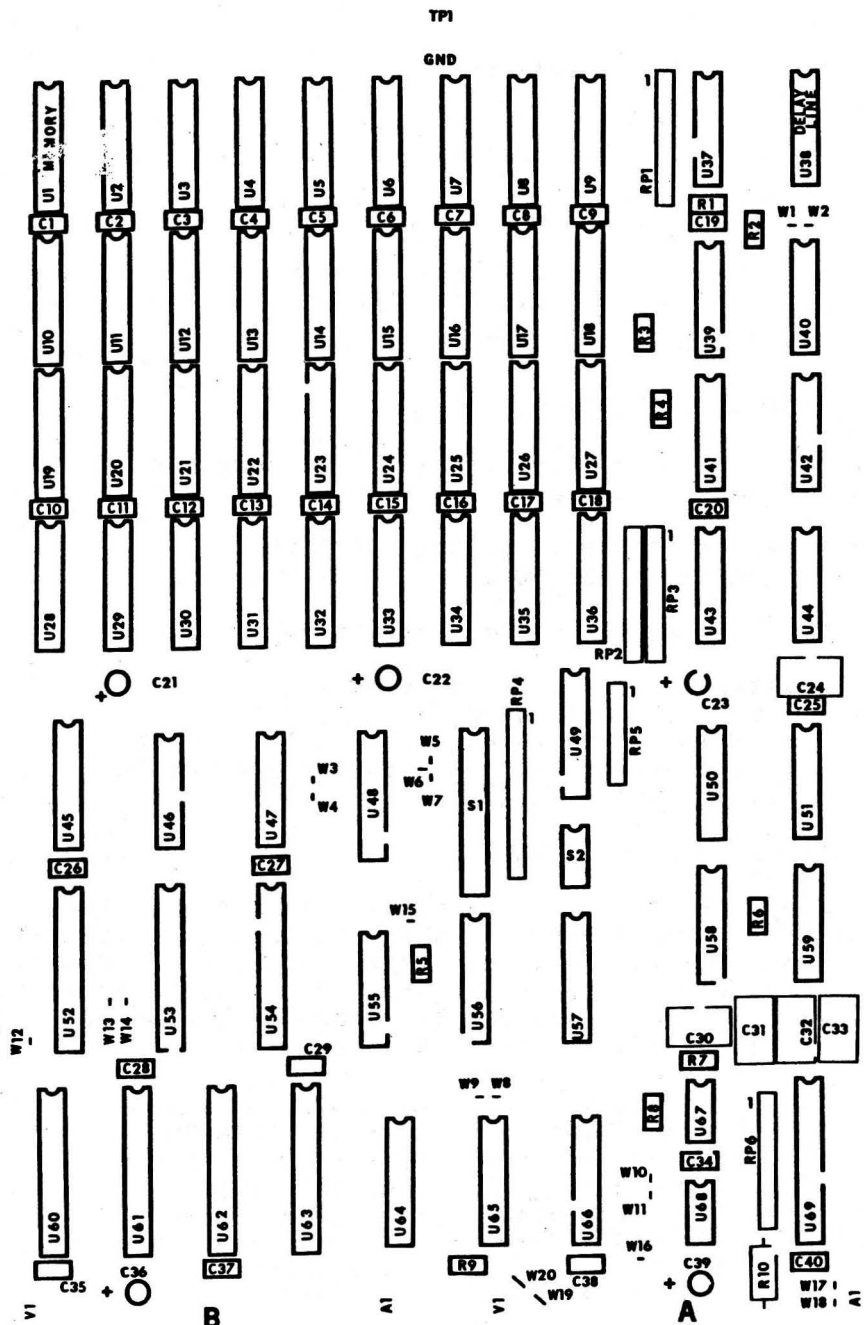

Figure 1.1 Jumper and Switch Placement



National Semiconductor Corporation
 2900 Semiconductor Drive, Santa Clara, Calif. 95051

SIZE
A

DWG. NO.
 409103882-001

A

SCALE

SHEET 6 OF

STARTING ADDRESS*	SWITCH SETTINGS**				
	S1-5	S1-4	S1-3	S1-2	S1-1
0K	0	0	0	0	0
4K	0	0	0	0	1
8K	0	0	0	1	0
12K	0	0	0	1	1
16K	0	0	1	0	0
20K	0	0	1	0	1
24K	0	0	1	1	0
28K	0	0	1	1	1
32K	0	1	0	0	0
36K	0	1	0	0	1
40K	0	1	0	1	0
44K	0	1	0	1	1
48K	0	1	1	0	0
52K	0	1	1	0	1
56K	0	1	1	1	0
60K	0	1	1	1	1
64K	1	0	0	0	0
68K	1	0	0	0	1
72K	1	0	0	1	0
76K	1	0	0	1	1
80K	1	0	1	0	0
84K	1	0	1	0	1
88K	1	0	1	1	0
92K	1	0	1	1	1
96K	1	1	0	0	0
100K	1	1	0	0	1
104K	1	1	0	1	0
108K	1	1	0	1	1
112K	1	1	1	0	0
116K	1	1	1	0	1
120K	1	1	1	1	0
124K	1	1	1	1	1

* In 4K word increments

** 0 = Open (OFF)
1 = CLOSED (ON)

Table 1.4 - STARTING ADDRESS SELECTION



National Semiconductor Corporation
2900 Semiconductor Drive, Santa Clara, Calif. 95051

SIZE
A

DWG. NO.
409103882-001

A

SCALE

SHEET 7 OF

4230007

ADDRESS RANGE	S1-9	S1-8	S1-7	S1-6
0K-128	0	0	0	0
128K-256K	0	0	0	1
256K-384K	0	0	1	0
384K-512K	0	0	1	1
512K-640K	0	1	0	0
640K-768K	0	1	0	1
768K-896K	0	1	1	0
896K-1024K	0	1	1	1
1024K-1152K	1	0	0	0
1152K-1280K	1	0	0	1
1280K-1408K	1	0	1	0
1408K-1536K	1	0	1	1
1536K-1664K	1	1	0	0
1664K-1792K	1	1	0	1
1792K-1920K	1	1	1	0
1920K-2048K	1	1	1	1

* To use addresses above 128K, 22 bit addressing must be used. In this case, the starting address will be the sum of the address in Table 1.5 and the lower limit of the range in Table 1.6.

** 0 = OPEN (OFF)
1 = CLOSED (ON)

Table 1.5. - ADDRESS RANGE SELECTION

I/O SPACE	S1-10
2K I/O	Close
4K I/O	Open

Table 1.6 I/O Space Selection



National Semiconductor Corporation
2900 Semiconductor Drive, Santa Clara, Calif. 95051

SIZE
A

DWG. NO.

409103882-001

A

SCALE

SHEET 8 OF

Memory Size*	Switch Settings			
	S2-4	S2-3	S2-2	S2-1
8K	0	0	0	0
16K	0	0	0	1
24K	0	0	1	0
32K	0	0	1	1
40K	0	1	0	0
48K	0	1	0	1
56K	0	1	1	0
64K	0	1	1	1
72K	1	0	0	0
80K	1	0	0	1
88K	1	0	1	0
96K	1	0	1	1
104K	1	1	0	0
112K	1	1	0	1
120K	1	1	1	0
128K	1	1	1	1

0 = open
1 = closed

* In K words, K = 1024

Table 1.7 Memory Size

1.4 BATTERY BACK-UP

The NS23M has a separated power plane so that battery back-up may be used if desired. The module requires +5 volts only and has the battery back-up input at pin AVI. To implement battery back-up remove jumper W20 and install W19. W20 may originally be in etch which means it must be cut. The battery back-up must be able to supply 1A at +5 volts d.c. to the memory module.

1.5 INTERNAL/EXTERNAL REFRESH

Refresh may be supplied from either an internal or external source. If supplied from an external source, a refresh cycle will be initiated on a low to high voltage transition and may be either synchronous or asynchronous. To maintain valid data, 256 refresh cycles must be completed every 4 ms. This can be accomplished by initiating one cycle every 15 +/- 1us. Figure 1.2 shows the suggested external refresh timing.



National Semiconductor Corporation
2900 Semiconductor Drive, Santa Clara, Calif. 95051

SIZE

A

DWG. NO.

409103882-001

A

SCALE

SHEET 9

OF

4230007

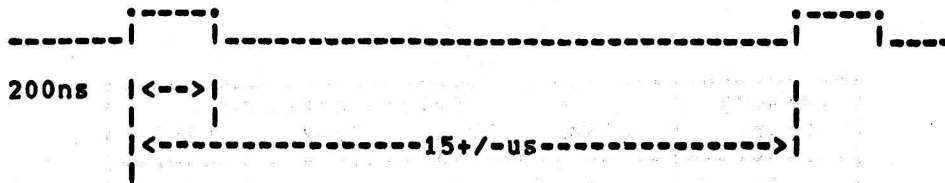

Figure 1.2 External Refresh Timing

1.6 INSTALLATION

The NS23M may be installed in any backplane wired for Q-Bus. Listed below are some guidelines:

A. Standard LSI-11 Backplanes

The NS23M Memory Card is designed to plug directly into Standard H9270 ("Quad") LSI-11 backplane/card guide assembly, and the DDV11-B ("Hex") expansion unit, the H9273-A Backplane and the H9281 backplane.

B. Precautions

In the H9270 backplane, slot one is reserved for the LSI-11 processor. The Memory Card may be inserted into any slot in this backplane with the exception of slot number one.

If the DDV11 expansion backplane is utilized, the memory card must be inserted into the A,B connectors or the C,D connectors of the backplane.

Install the card with components facing row 1, apply power and run system diagnostics. Never install or remove modules from the backplane while power is applied.

2.0 MAINTENANCE

No routine maintenance is required on the NS23M. If problems are encountered check the following:

- o Is the system configured properly? Is the bus priority daisy chain maintained?
- o Are all switches and jumpers configured properly?
- o Are the board edge contacts clean and is the board completely seated?
- o Is DC power present at the backplane?



National Semiconductor Corporation
2900 Semiconductor Drive, Santa Clara, Calif. 95051

SIZE
A

DWG. NO.

409103882-001

A

SCALE

SHEET 10 OF

4230007

REFERENCE DESIGNATION	
LAST USED	NOT USED
C40	
R12	
RP6	
S2	
TPI	
U69	
W20	

VOLTAGE CHART				
TYPE	+5V	+5VB	GND	REFERENCE DESIGNATION
74LS00		14	7	U40
74S00		14	7	U47, 59
74S08		14	7	U44, 55
74S22		14	7	U37
74S32		14	7	U43
74S37		14	7	U39, 41
74S74		14	7	U58
74S132		14	7	U51
74S135		16	8	U45
74S175		16	8	U48
74LS240		20	10	U69
74S260		14	7	U50
74S283		16	8	U49, 56, 57
74S373		20	10	U52, 53, 54
74S393		14	7	U46
75452B		8	4	U68
2908	20		5,16	U60, 61, 62, 63
8641	16		8	U64, 65, 66
LM555		8	1	U67
DELAY LINE, 200NS			1,14	U38
74LS74		14	7	U42

REVISIONS			
REV	DATE	ECO NO.	APPVD
A	10-11-81	PCO 24165	
B	11-11-81	PCO 24173	
C	11-11-81	PCO 24188	
D	12-7-81	PCO 24201	
E	6-3-82	PCO 24285	

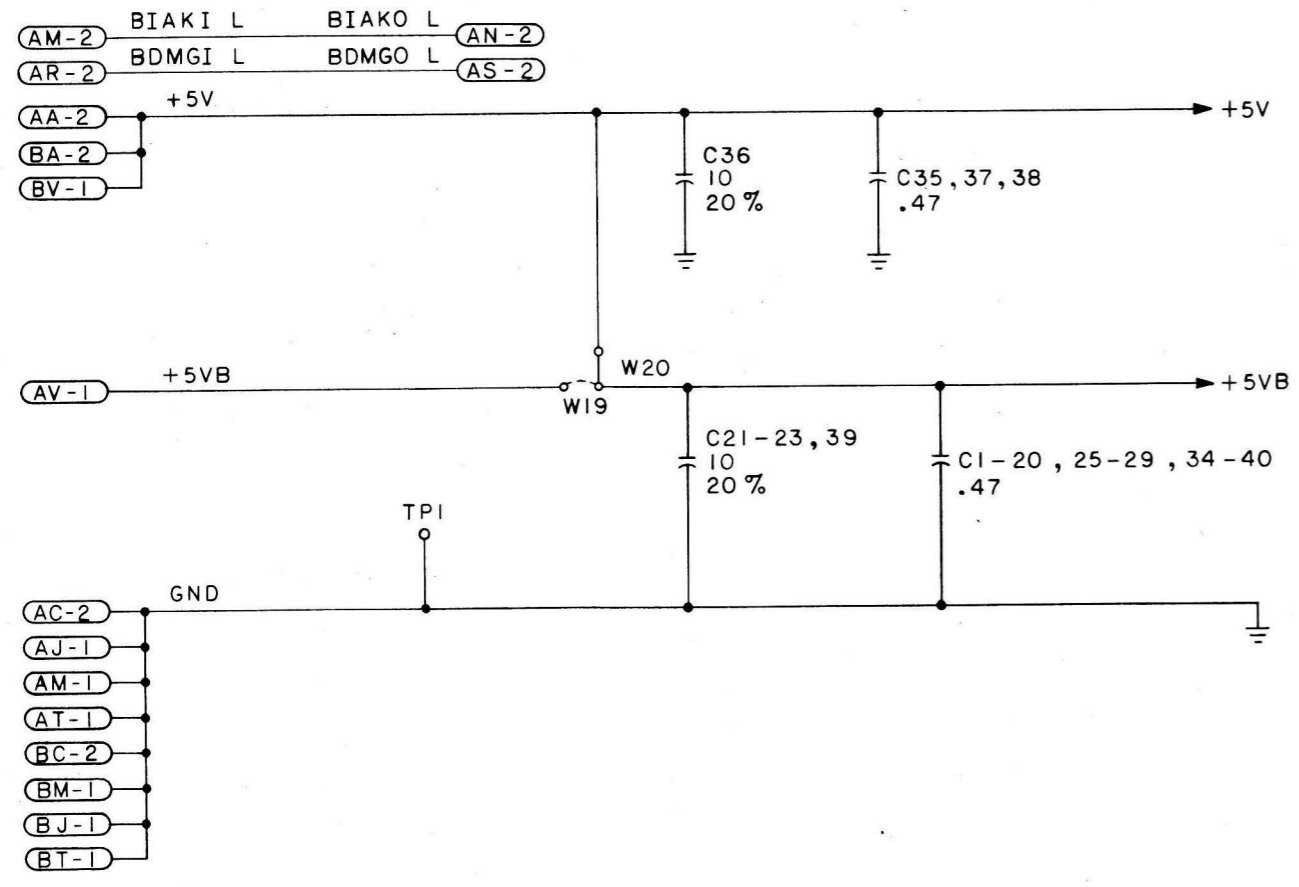
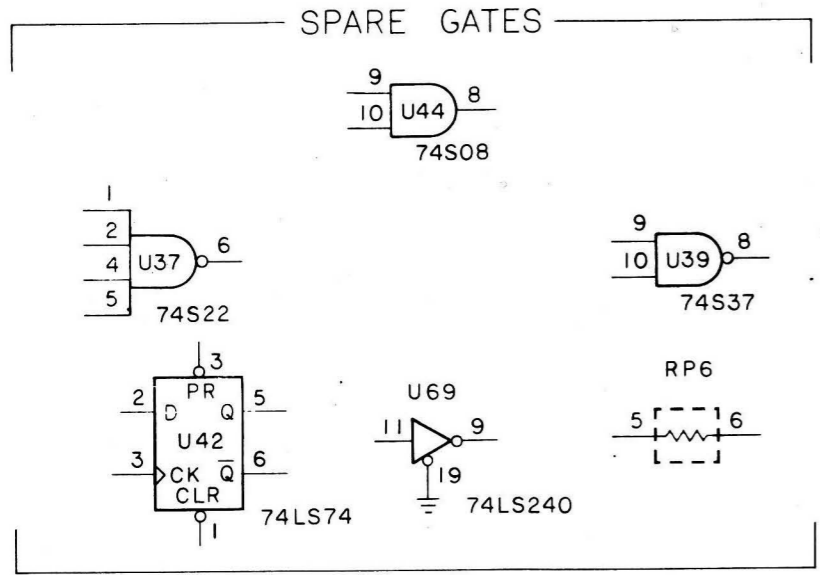

NOTES UNLESS OTHERWISE SPECIFIED:

1. RESISTANCE VALUES ARE IN OHMS, 1/8W, 5%.
2. CAPACITANCE VALUES ARE IN MICROFARADS, 25V, +80% -20%
3. □ INDICATES +5V ONLY.
4. ALL RESISTOR PACKS (RP) ARE 22 OHMS.

MATERIAL	DR BY <i>W. J. ...</i> 6-3-81	National Semiconductor Corporation 2900 Semiconductor Drive, Santa Clara, Calif 95051
FINISH	CHK BY <i>...</i>	
UNLESS OTHER SPECIFIED DIMENSIONS ARE IN INCHES AND INCLUDE CHEMICALLY APPLIED OR PLATED FINISHES REMOVE BURRS AND SHARP EDGES BREAK SHARP CORNERS 015 MAX		SCHEMATIC DIAGRAM NS23M
TOLERANCE ANG 2 PL 3 PL		SIZE DR NC D 870103882 001
NEXT ASSY	USED ON	SCALE NONE SHEET 1 OF 5

REVISIONS			
REV	DATE	ECO NO	APPVD
		SEE SHEET 1	

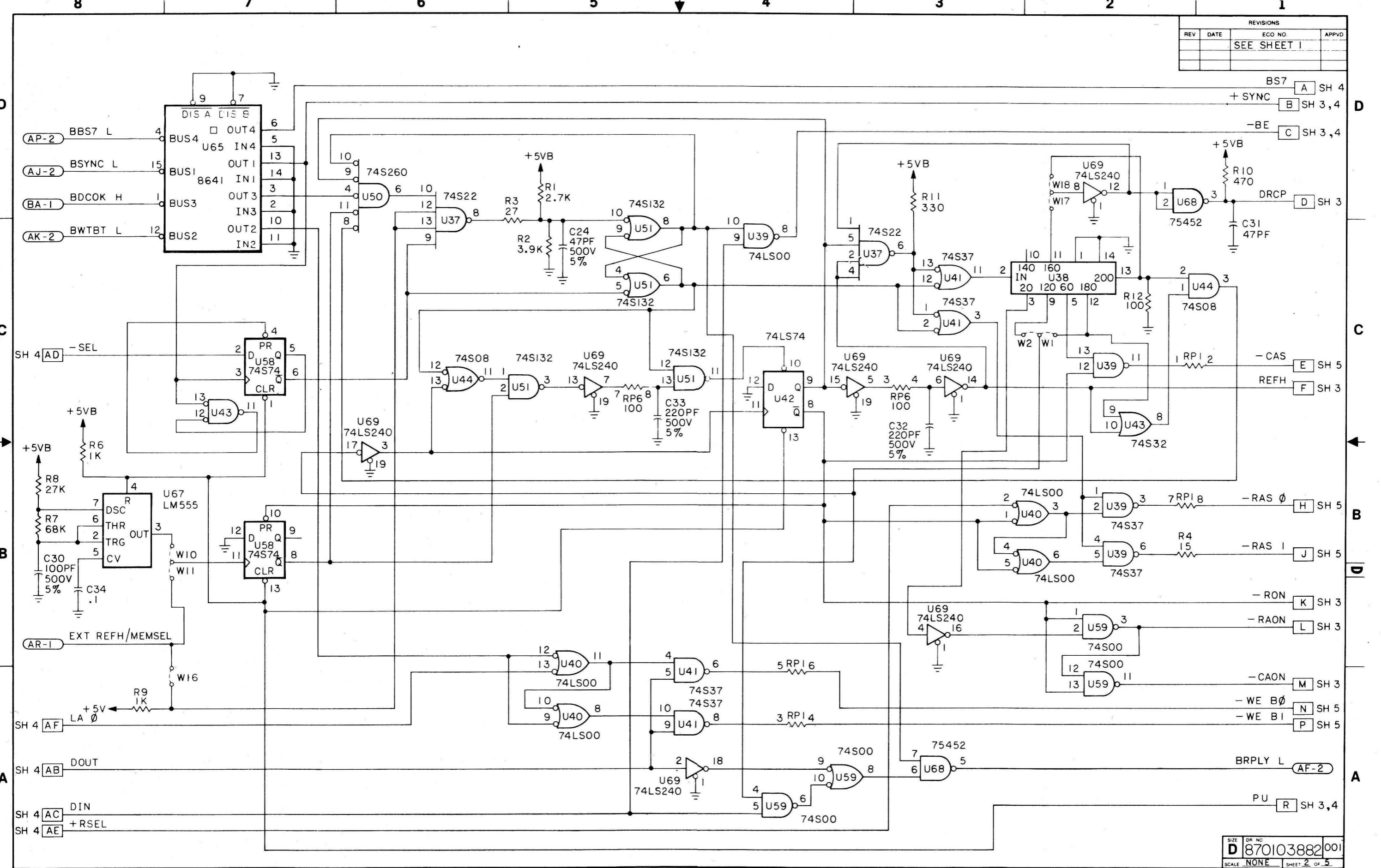

SIZE OR NO
D 870103882 001
 SCALE NONE SHEET 2 OF 5

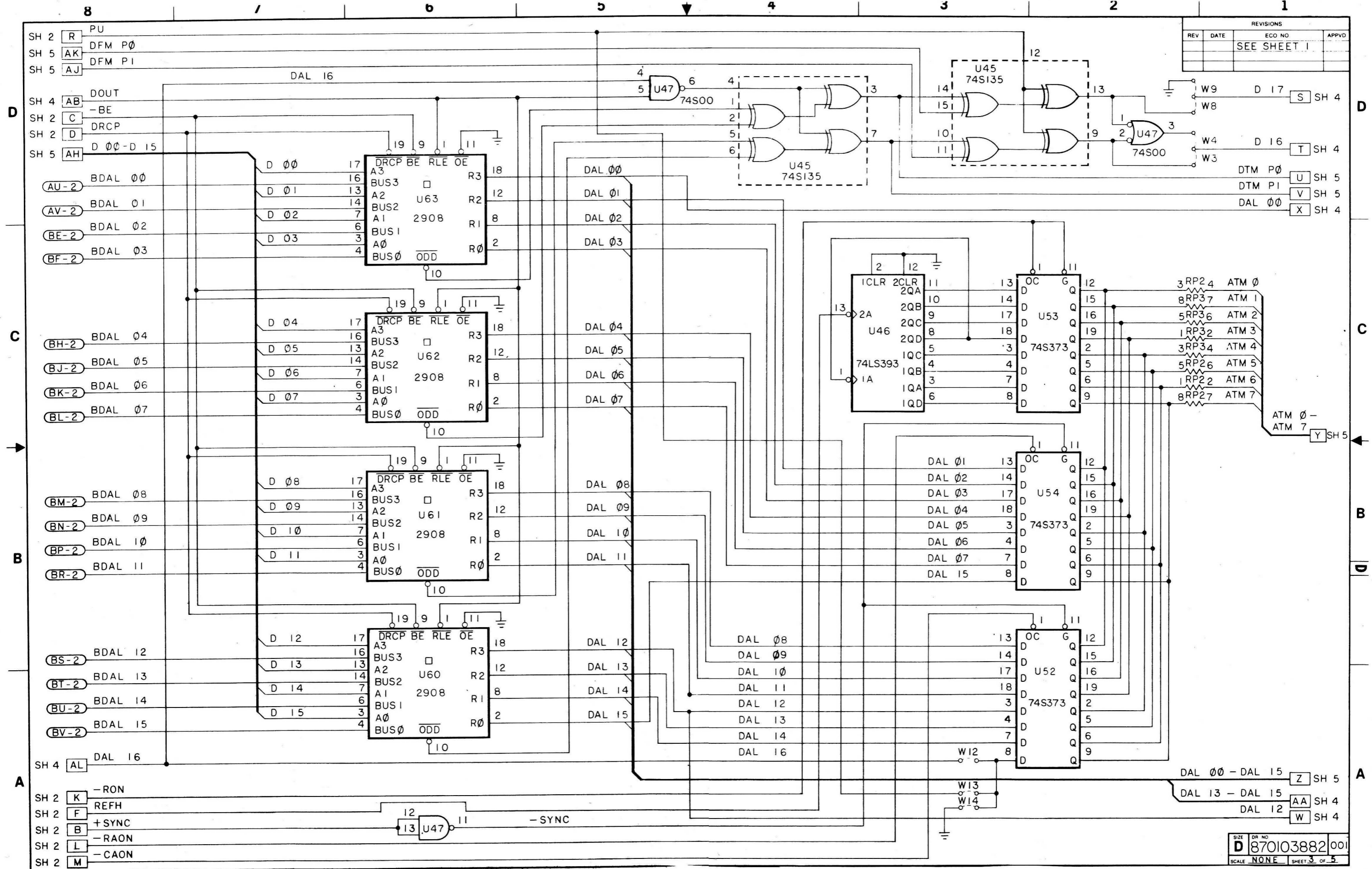

REVISIONS			
REV	DATE	ECO NO	APPVD
		SEE SHEET 1	

SIZE DR NO
D 870103882 001
 SCALE NONE SHEET 3 OF 5

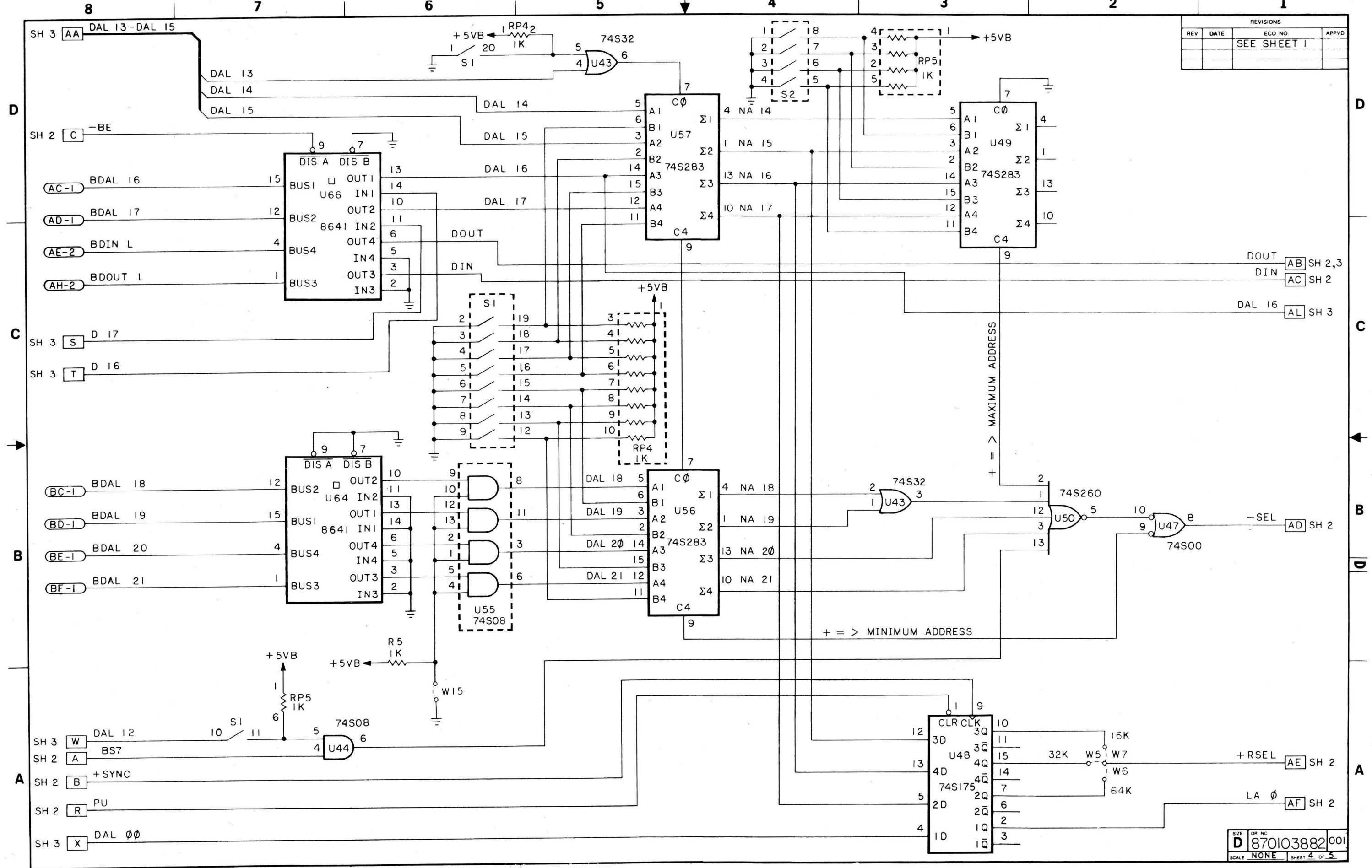

REVISIONS			
REV	DATE	ECO NO	APPVD
		SEE SHEET 1	

SIZE	DR NO	
D	870103882	001
SCALE	NONE	SHEET 4 OF 5

REVISIONS			
REV	DATE	ECO NO	APPVD
		SEE SHEET 1	

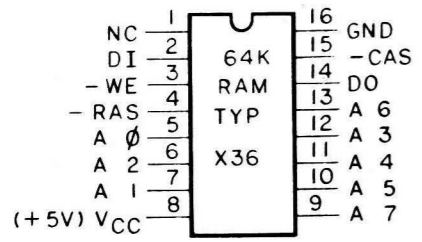
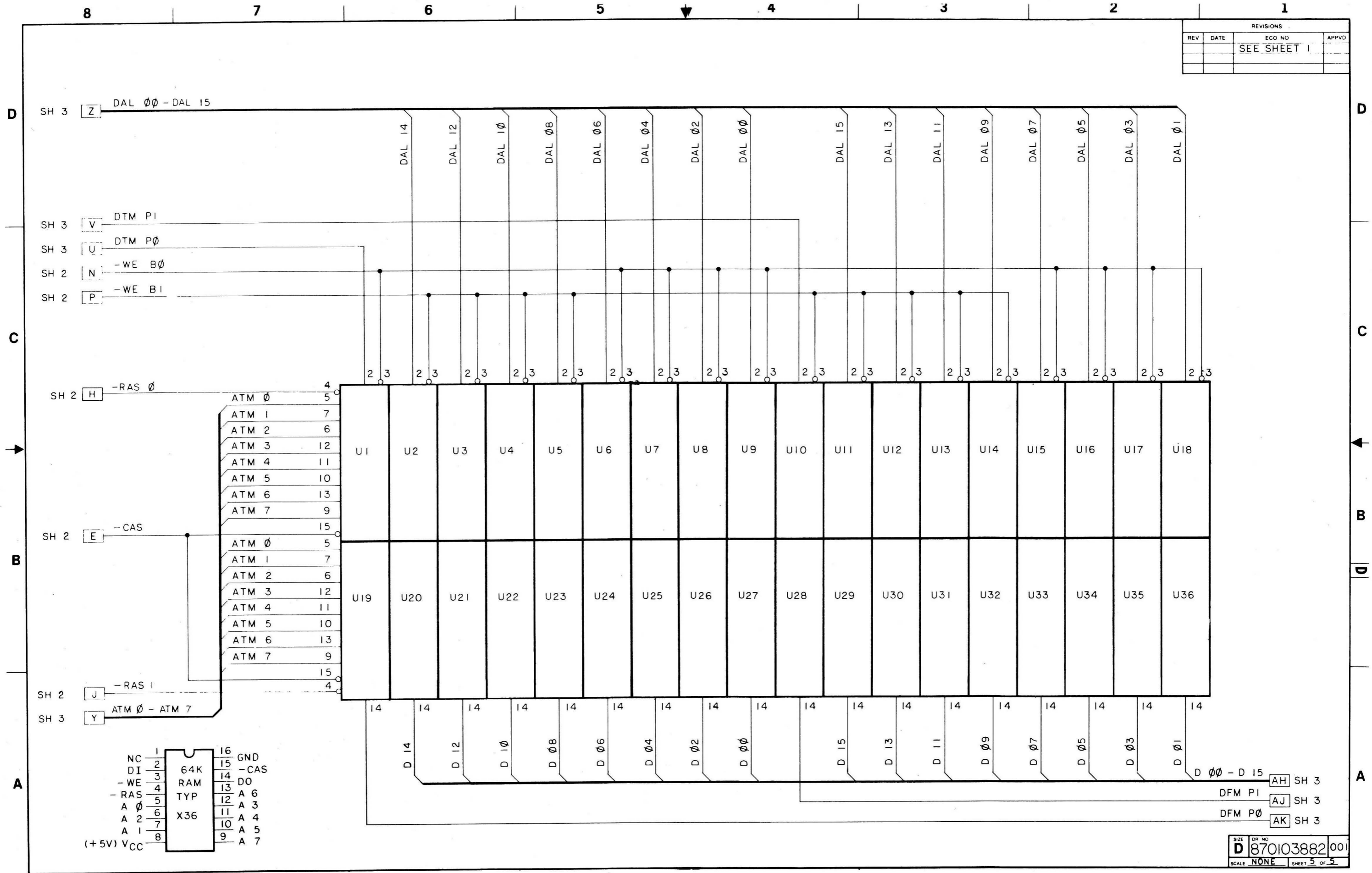

AH SH 3
 AJ SH 3
 AK SH 3

SIZE OR NO
D 870103882 001
 SCALE NONE SHEET 5 OF 5