

TECHNICAL MANUAL

MODEL BASF 6106/08

MINI DISK DRIVE

PART - NO. 80 347-047



BASF Aktiengesellschaft

Carl - Bosch - Straße

6700 Ludwigshafen

Tel. 0621 / 601 - TLX 464 695

REVISION	RECORD OF REVISION	REMARKS
01	VS II	Valid for SN 0000 -/- 0400
02	VS III	Valid for SN 0500 -/- 1300
03	VS IV	Valid for SN 2100 -/-
04	Corrections	
05	Add. Model 6108	Valid for Drives with PCB # 88366
06	Update	None

L I S T O F C O N T E N T S

SECTION	PAGE	SECTION	PAGE
1.	INTRODUCTION		1-1
1.1	General	2.2.8	Type of Heads 2-20
1.2	Related Documentation	2.2.8.1	Read/Write Head 2-20
1.3	Description	2.2.8.2	Side Select Logic 2-21
1.4	Specification Summary	2.2.9	Write Circuits 2-22
1.5	Options Summary	2.2.9.1	Write Initiate 2-22
1.5.1	Factory Installed Option	2.2.9.2	Write Logic 2-22
1.5.2	Jumper Options	2.2.9.3	Erase Delay Logic 2-24
1.6	Recording Media	2.2.10	Read Circuits 2-25
1.7	Recording Formats	2.2.10.1	Read Initiate and Read Block Diagram 2-25
1.7.1	FM Encoding	2.2.10.2	Read/Write Select 2-26
1.7.2	MFM Encoding	2.2.10.3	Read Amplifiers and Filter Network 2-26
1.8	Track Format	2.2.10.4	Active Differentiator and Comparator 2-27
1.8.1	Soft Sector Track Formats	2.2.10.5	Time Domain Filter and Crossover Detector 2-27
1.8.1.1	Soft Sector Track Format for Single Density with 16 Sectors/Track à 128 Bytes	2.2.10.6	Timing Diagram Read Circuits 2-28
1.8.1.2	Soft Sector Track Format for Single Density (9 Sectors per Track à 256 Bytes)	2.2.11	DC-Control and Power On Reset Logic 2-29
1.8.1.3	Soft Sector Track Format for Double Density (16 Sectors per Track à 256 Bytes)	2.2.11.1	DC-Control 2-29
		2.2.11.2	Power On Reset Logic 2-29
2.	THEORY OF OPERATION		
2.1	Functional Description		2-1
2.1.1	Drive Mechanism		2-2
2.1.2	Spindle and Front Door Mechanism		2-2
2.1.3	Positioning Mechanism		2-3
2.1.4	Head Load Mechanism		2-4
2.2	Logic Description		2-5
2.2.1	Interface Logic		2-5
2.2.1.1	Input Interface		2-6
2.2.1.2	Output Interface		2-6
2.2.1.3	Jumper Options		2-7
2.2.2	Stepper Motor Control		2-12
2.2.3	Drive Motor Control		2-14
2.2.4	Head Load Logic		2-15
2.2.5	Track Zero Detector		2-16
2.2.6	Write Protect Detector		2-17
2.2.7	Index/Sector- and Ready Detector		2-18
2.2.7.1	Index/Sector Detection		2-18
2.2.7.2	Ready Detection		2-19

LIST OF CONTENTS

SECTION	PAGE	SECTION	PAGE
3.	INSTALLATION AND OPERATION	3-1	
3.1	Installation	3-1	
3.1.1	General	3-1	
3.1.2	Unpacking and Inspection	3-1	
3.1.3	Connecting Cables	3-2	
3.1.4	Connectors	3-2	
3.1.4.1	DC-Connector	3-2	
3.1.4.2	Signal Connector	3-2	
3.1.4.3	Frame Connector	3-2	
3.1.4.4	Interconnecting Diagram	3-2	
3.1.5	Logic Levels and Termination	3-4	
3.1.6	Connecting Configuration	3-4	
3.1.6.1	Single Drive Configuration	3-4	
3.1.6.2	Multiple Drive Configuration	3-4	
3.1.7	Selection of the Desired Option	3-6	
3.1.7.1	Selection Options	3-6	
3.1.7.2	Head Load Options	3-6	
3.1.7.3	In Use / Disk Change Option	3-6	
3.1.7.4	Door Lock Options	3-6	
3.1.7.5	Activity LED Options	3-7	
3.1.7.6	Write Protect Option	3-7	
3.1.7.7	Stepper Motor Switching	3-7	
3.1.7.8	Jumper Matrix	3-8	
3.1.8	Drive Mounting	3-10	
3.1.8.1	Mounting Positions	3-10	
3.1.8.2	Mounting Dimensions	3-10	
3.2	Operation	3-11	
3.2.1	General	3-11	
3.2.2	Mini Disk Storage and Handling	3-11	
3.2.3	Write Protect	3-12	
3.2.3.1	Write Protect if notch open (optional)	3-12	
3.2.3.2	Write Protect if notch covered (ECMA)	3-12	
4.	MAINTENANCE	4-1	
4.1	General	4-1	
4.2	Tools and Test Equipment	4-1	
4.3	Checks, Adjustment and Replacements	4-2	
4.3.1	PCB Replacement	4-2	
4.3.2	Spindle Drive System	4-2	
4.3.2.1	Drive Motor and Drive Belt Checks	4-2	
4.3.2.2	Drive Belt Tension Check	4-2	
4.3.2.3	Drive Belt Replacement and Tension Adjustment	4-3	
4.3.2.4	Drive Motor Speed Check	4-3	
4.3.2.5	Drive Motor Speed Adjustment	4-3	
4.3.2.6	Drive Motor Speed Adjustment using a Frequency Counter	4-4	
4.3.2.7	Drive Motor Replacement	4-4	
4.3.3	Positioning System	4-5	
4.3.3.1	Track Adjustment Check	4-5	
4.3.3.2	Track Adjustment Procedure	4-6	
4.3.3.3	Adjustment Check for Optical Track Zero Switch	4-7	
4.3.3.5	Track Zero Switch Replacement	4-8	
4.3.3.6	Head Carriage Replacement	4-9	
4.3.3.7	Head Load Pad Replacement (6106)	4-9	
4.3.4	Head Load Mechanism	4-10	
4.3.4.1	Head Load Solenoid Replacement	4-10	
4.3.4.2	Head Load Actuator Check	4-10	
4.3.5	Read/Write Electronics	4-11	
4.3.5.1	Jitter Check and Adjustment	4-11	
4.3.5.2	Read Amplitude Check	4-11	
4.3.6	Photo Transistors and LED's	4-12	
4.3.6.1	Photo Transistor Replacement	4-12	
4.3.6.2	LED-Replacement	4-12	
4.3.6.3	Index Detector Adjustment Check	4-12	
4.3.6.4	Index Detector Adjustment	4-13	
4.4	Location of Testpoints, IC's, Potentiometers and Connectors	4-14	
5.	Spare Parts		
5.1	Attachment 1, Spare Parts for BASF 6106		
5.2	Attachment 2, Spare Parts for BASF 6103		

L I S T O F I L L U S T R A T I O N S

FIGURE	PAGE	FIGURE	PAGE
1 - 1	Model BASF 6106/6108 Mini-Disk-Drive	1-1	
1 - 2	Flexible Disk Construction and Dimensions	1-5	
1 - 3	FM-Encoding	1-5	
1 - 4	MFM-Encoding	1-5	
1 - 5	Address Mark Patterns	1-6	
1 - 6	Soft Sector Track Format with 16 Sectors per Track	1-7	
1 - 7	Simplified EDC Shift Register	1-8	
1 - 8	Soft Sector Track Format with 9 Sectors per Track	1-9	
1 - 9	Soft Sector Track Format for Double Density (MFM)	1-10	
2 - 1	Block Diagram BASF 6106/6108	2-1	
2 - 2	Drive Mechanism	2-2	
2 - 3	Spindle and Front Door Mechanism	2-2	
2 - 4 a	Positioning Mechanism 6106	2-3	
2 - 4 b	Positioning Mechanism 6108	2-3	
2 - 5 a	Head Load Mechanism 6106	2-4	
2 - 5 b	Head Load Mechanism 6108	2-4	
2 - 6	Interface Logic	2-5	
2 - 7	Auto Select Option	2-7	
2 - 8	Radial Select Option	2-7	
2 - 9	Auto Head Load Option	2-8	
2 - 10	Selected Head Load Option	2-8	
2 - 11	Radial Head Load Option	2-8	
2 - 12	Door Lock Latch Option	2-9	
2 - 13	Timing Diagram Door Lock Latch Option	2-9	
2 - 14	Disk Change Logic	2-11	
2 - 15	Timing Diagram Disk Change Logic	2-11	
2 - 16	Stepper Motor Control	2-13	
2 - 17	Stepper Motor Timing Diagram	2-13	
2 - 18	Drive Motor Control	2-14	
2 - 19	Head Load Circuit Door Lock Solenoid and Activity LED Driver	2-15	
2 - 20	Head Load Timing Diagram	2-15	
2 - 21	Track Zero Detector	2-16	
2 - 22	Track Zero Timing Diagram	2-16	
2 - 23	Write Protect Detector	2-17	
2 - 24	Index Detector	2-18	
2 - 25	Ready Detector	2-19	
2 - 26	Ready Timing	2-19	
2 - 27	Track Geometry	2-20	
2 - 28	Electrical Connection of the Read/Write Head	2-20	
2 - 29	Side Select Logic	2-21	
2 - 30	Write Initiate Timing	2-22	
2 - 31 a	Simplified Write Circuits 6106/6108	2-22	
2 - 31 b	Timing Diagram Write Operation (Simplified)	2-23	
2 - 32	Erase Delay Logic	2-23	
2 - 33	Erase Delay Timing	2-24	
2 - 34	Read Circuits 6106/6108 (Simplified)	2-24	
2 - 35	Read Initiate Timing	2-25	
2 - 36	Read/Write Select Logic	2-25	
2 - 37	Read Amplifiers and Filter Network	2-26	
2 - 38	Active Differentiator and Comparator	2-27	
2 - 39	Time Domain Filter and Crossover Detector	2-28	
2 - 40	Timing Diagram Read Circuits	2-28	
2 - 41	DC-Control Logic	2-29	
2 - 42	Power On Reset Logic	2-29	
2 - 43	Timing Diagram Power On Reset	2-29	
3 - 1	Shipping Configuration	3-1	
3 - 2	DC-Connector	3-2	
3 - 3	Interconnecting Diagram	3-3	
3 - 4	Interface Logic Levels	3-4	
3 - 5	Recommended Driver/Receiver Circuit	3-4	
3 - 6	Single Drive Configuration	3-4	
3 - 7	Radial Select Configuration	3-5	
3 - 8	Daisy Chain Select Configuration	3-5	
3 - 9	Part Locations (Principal)	3-9	
3 - 10	Mounting Specification	3-10	
3 - 11	Flexy Disk Loading	3-11	
3 - 12	Write Protect Feature (ECMA)	3-12	
3 - 13	Write Protect Feature (optional)	3-12	
5 - 1	Parts Breakdown 6106	5-2	
5 - 2	Parts Breakdown 6108	5-3	

L I S T O F T A B L E S

TABLE		PAGE
1 - 1	Specification Summary	1-2
1 - 2	Factory Installed Option	1-4
1 - 3	Jumper Selectable Options	1-4
2 - 1	Input Signals	2-6
2 - 2	Output Signals	2-6
2 - 3	Write Protect Jumpering	2-9
2 - 4	Sequence of the Stepper Motor Signals	2-12
3 - 1	DC-Power Requirements	3-2
3 - 2	Recommended J1 Mating Connectors	3-2
3 - 3	Select Options Jumpering	3-6
3 - 4	Head Load Option Jumpering	3-6
3 - 5	In Use Disk Change Option Jumpering	3-6
3 - 6	Door-Lock Options Jumpering	3-6
3 - 7	Activity LED-Option Jumpering	3-7
3 - 8	Write Protect Option Jumpering	3-7
3 - 9	Stepper Motor Switching Option Jumpering	3-7
3 - 10	Option Jumper Matrix	3-8
3 - 11	Flexy Disk Loading	3-11
3 - 12	Flexy Disk Unloading	3-11
4 - 1	Standard Tools and Test Equipment	4-1
4 - 2	Special Tools and Test Equipment	4-1
5 - 1	Spare Parts BASF 6106	5-4
5 - 2	Spare Parts BASF 6108	5-7
5 - 3	R/W PCB-88356	5-10
5 - 4	R/W PCB-88366	5-13

SECTION 1

INTRODUCTION

1.1 GENERAL

This manual contains descriptive material and procedures useful in installation, operation, maintenance and repair of the BASF Mini Disk Drive Models BASF 6106 and BASF 6108.

1.2 RELATED DOCUMENTATION

Product- and Interface Specification

BASF 6106/6108

30 307-046

1.3 DESCRIPTION

The models BASF 6106 and BASF 6108 are very compact random access data storage units, which utilize a 5.25" Flexy Disk as storage medium. The BASF 6106 stores data on one side of the Flexy Disk, the BASF 6108 on both sides.

The Flexy Disk is rotated at 300 RPM yielding a data transfer rate of 125,000 bits per second in single density. Up to 125 kbytes of raw data may be stored on a single recording surface in single density, and twice as much in double density.

Data capacity on all 40 tracks varies from 81.92 kbytes (BASF 6106, 16 sectors at 128 bytes) to 363.64 kbytes, so increasing capacity more than four times by using the BASF 6108 with 9 sectors of 512 bytes each.

The mini disk drives are equipped with a DC-controlled spindle drive motor, thus no AC-Power is needed. Ceramic read/write heads with tunnel erase are used within the BASF 6106/6108 to ensure reliable data recording.

The heads are positioned with a fourphase DC-stepper motor actuator, utilizing a spiral wheel which provides precise location of the read/write head or heads on the track.

Applications for both types of mini disk drives comprise word processing and text editing systems, program storage for mini and micro computers, "intelligent" desktop calculators and the hobby micro computer market.

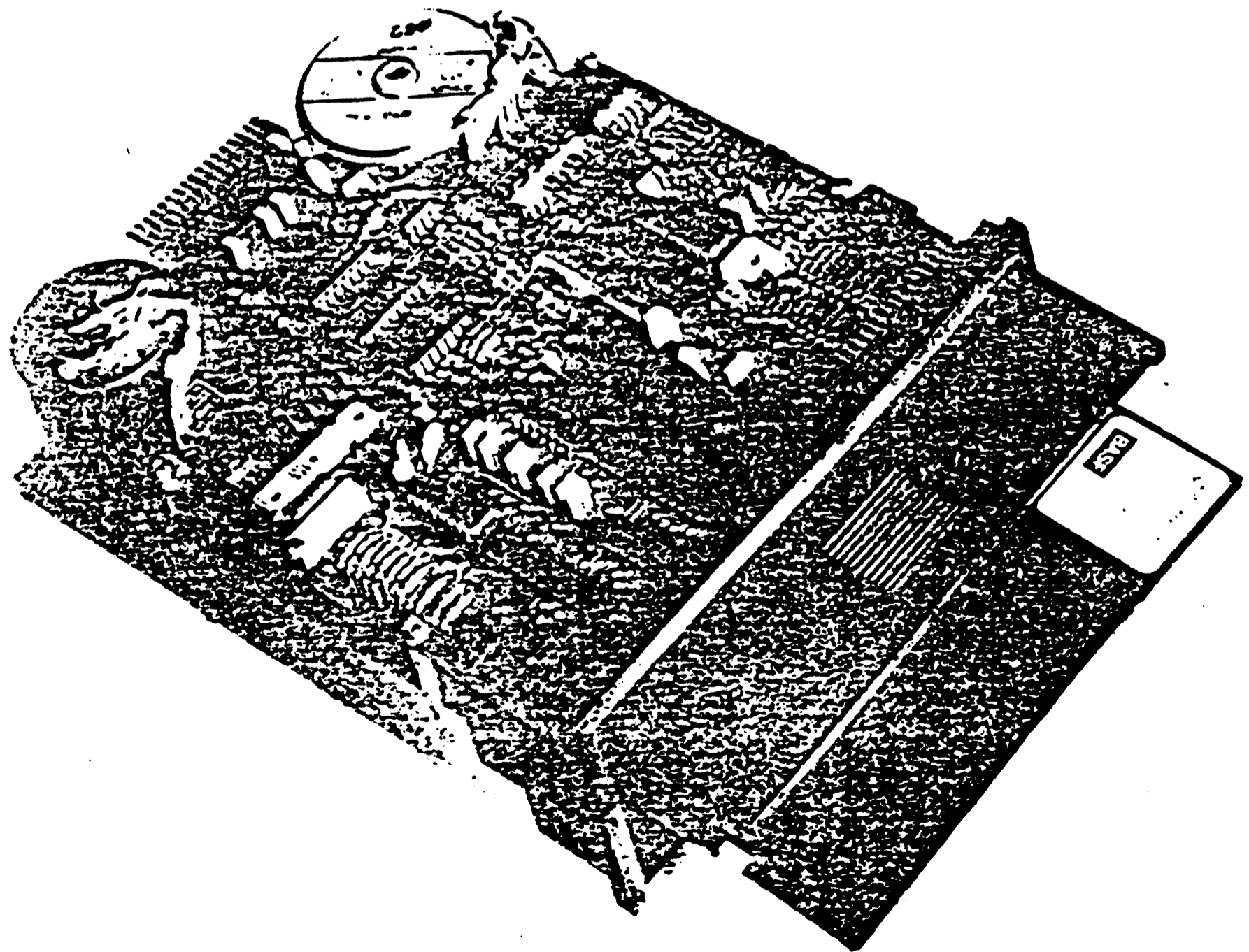

FIGURE 1 - 1 MODEL BASF 6106/6108 MINI DISK DRIVE

1.4 SPECIFICATION SUMMARY

A comprehensive list of principal specifications for model BASF 6106 and model BASF 6108 is provided in table 1 - 1.

P E R F O R M A N C E S P E C I F I C A T I O N S				
CAPACITY	BASF 6106 (single sided)		BASF 6108 (double sided)	
	Single Density	Double Density	Single Density	Double Density
Unformatted				
per Disk	125 kilobytes	250 kilobytes	250 kilobytes	500 kilobytes
per Surface	125 kilobytes	250 kilobytes	125 kilobytes	250 kilobytes
per Track	3.125 kilobytes	6.250 kilobytes	3.125 kilobytes	6.25 kilobytes
Formatted (16 Sectors/Track)				
per Disk	81.920 kbytes	163.840 kbytes	163.840 kbytes	327.680 kbytes
per Surface	81.920 kbytes	163.840 kbytes	81.920 kbytes	163.840 kbytes
per Track	2.048 kbytes	4.096 kbytes	2.048 kbytes	4.096 kbytes
per Sector	128 bytes	256 bytes	128 bytes	256 bytes
TRANSFER RATE	125 kilobits/s	250 kilobits/s	125 kilobits/s	250 kilobits/s
LATENCY				
Maximum	200 ms			
Average	100 ms			
ACCESS TIME				
Track to track positioning	12 ms			
Average	240 ms			
Settling Time	max. 48 ms			
Head Load Time	max. 35 ms			
Drive Motor Start Time	max. 650 ms			
F U N C T I O N A L S P E C I F I C A T I O N S				
	BASF 6106		BASF 6108	
	Single Density	Double Density	Single Density	Double Density
Rotational Speed	300 RPM \pm 2,5 %	300 RPM \pm 2,5 %	300 RPM \pm 2,5 %	300 RPM \pm 2,5 %
Recording Density (inside Track)	3979 BPRAD (2768 BPI)	7958 BPRAD (5536 BPI)	3979 BPRAD (2768 BPI)	7958 BPRAD (5536 BPI)
Flux Density	7958 FTPRAD (5536 FCI)	7958 FTPRAD (5536 FCI)	7958 FTPRAD (5536 FCI)	7958 FTPRAD (5536 FCI)
Track Density	48 TPI	48 TPI	48 TPI	48 TPI
Track Radius				
Track 00	57,15 mm	57,15 mm	55,03 mm ^{+))}	55,03 mm ^{+))}
Track 39	36.5125 mm	36.5125 mm	34.3958 mm ^{+))}	34.3953 mm ^{+))}
Encoding Method	FM	MFM	FM	MFM
Media Requirements	BASF Flexy Disk 5.25"-1	BASF Flexy Disk 5.25"-1D	BASF Flexy Disk 5.25"-2	BASF Flexy Disk 5.25"-2D

+) On Side 1, Side 0 see 6106
Track radius 1 is 2. 1167 mm
smaller then track radius 0.

TABLE 1 - 1 SPECIFICATION SUMMARY (continued)

PHYSICAL SPECIFICATIONS

Environmental limits

Ambient temperature on disk surface (operation)

10° to 50°C (50°F to 120°F)

Relative humidity

20 % to 80 %

Maximum wet bulb

29°C (84°F)

DC-voltage requirements

+ 12 VDC \pm 5 % 0,7 A⁺⁾
 max. 100 mVpp ripple
 + 5 VDC \pm 5 % 0,5 A
 max. 50 mVpp ripple

+) motor starting current
 max. 0.65 A for max. 50 msec
 head load start current
 0.7 A for 50 msec

Power dissipation

10.0 Watts operating
 4.0 Watts stand by (motor off)
 7.5 Watts motor on and deselected

Mechanical dimensions:

Width
 Height
 Depth
 Weight

146.1 mm (5.75 inch)
 53.5 mm (2.11 inch)
 190.0 mm (7.48 inch)
 1.4 kg

RELIABILITY SPECIFICATIONS

MTBF

10000 POH under typical usage⁺⁾

Unit life time

5 years

MTTR

30 minutes

Error rates:

Soft read errors
 Hard read errors
 Seek errors

1 per 10⁸ bits read
 1 per 10¹¹ bits read
 1 per 10⁶ seeks

+) Duty cycle of Spindle Drive Motor: 20% of POH

MEDIA SPECIFICATIONS

Jacket

133.3 mm (5.25 inch) square

Disk

130.2 mm (5.125 inch) diameter

Center hole

28.57 mm (1.125 inch) diameter

TABLE 1 - 1 SPECIFICATION SUMMARY

1.5 OPTIONS SUMMARY

The following tables list the options of the BASF 6106 and BASF 6108 Mini Disk Drives.

1.5.1 FACTORY INSTALLED OPTION

Option	Function
Door Lock Solenoid	Locks the front door under control of the users software.

TABLE 1 - 2 FACTORY INSTALLED OPTION

1.5.2 JUMPER OPTIONS

The following options are selectable by jumpers on the PCB. Refer to Table 3 - 10 for jumper option matrix.

Option	Function
RADIAL SELECT	Allows the connection of three mini disk drives to the host system. Each drive has its own address (0,1,2) selectable by jumper.
AUTO SELECT	The interface is always enabled (drive is always selected). The SELECT-lines are not used.
HEAD LOAD	<p>Loading of the head can be accomplished in three modes:</p> <ul style="list-style-type: none"> ● Selected Head Load (INT.SELECT + HEAD LOAD) ● Auto Head Load (INT. SELECT) ● Radial Head Load (HEAD LOAD) <p>The head will be loaded only if the inserted mini disk rotates.</p>
IN USE	Pin 34 of the interface is used as IN USE input signal and controls the door lock solenoid and the activity indicator. If this option is used the disk change option must be disabled.

TABLE 1 - 3 JUMPER SELECTABLE OPTIONS

Option	Function
DOOR LOCK LATCH	Allows locking of the door without maintaining the IN USE signal activated by storing the state of the IN USE-signal into the IN USE-flipflop. To use this option the IN USE-option must be jumpered.
DISK CHANGE	Notifies the host system that the mini disk has been changed. If this option is used, the IN USE-option must be disabled.
DOOR LOCK	<p>Locking of the door can be accomplished as follows:</p> <ol style="list-style-type: none"> 1. by the IN USE-signal 2. by the IN USE-FF (DOOR LOCK LATCH) 3. if the drive is selected (I/O ENA activ) 4. if the head will be loaded (HLOADENA activ) 5. if 1. or 3. is true 6. if 1. or 2. or 3. is true 7. if 1. or 4. is true 8. if 1. or 2. or 4. is true
ACTIVITY INDICATOR OPTIONS	<p>The lighting of the activity LED is selectable by jumper to one of the following conditions:</p> <ul style="list-style-type: none"> ● the head is loaded and the drive is ready ● the door is locked and the drive is ready
WRITE PROTECT OPTION	Allows protection of the mini disk against overwrite if the write protect notch is closed (ECMA, Shugart).
STEPPER MOTOR SWITCHING	The stepper motor is switched on and off together with the drive motor if a jumper is inserted. If the jumper is not inserted, the stepper motor will be enabled as long as power is supplied.

1.6 RECORDING MEDIA

The BASF mini disk drives use a removable 130 mm (5.25 inch) diameter flexible disk as storage media. Fig. 1-2 shows construction and dimensions of a typical 5.25" Flexy Disk.

The recommended recording media is:

for model BASF 6106 mini disk drives:

single density: 5.25"-1
double density: 5.25"-1 D

for model BASF 6108 mini disk drives:

single density: 5.25"-2
double density: 5.25"-2 D

The Flexy Disk is an oxide coated flexible disk enclosed in a protective plastic envelope. The protective envelope contains apertures for head contact, index detection, write protect detection and drive spindle loading.

The write protect notch is used to protect the written data on the Flexy Disk (see 2.2.6 Write Protect Detector).

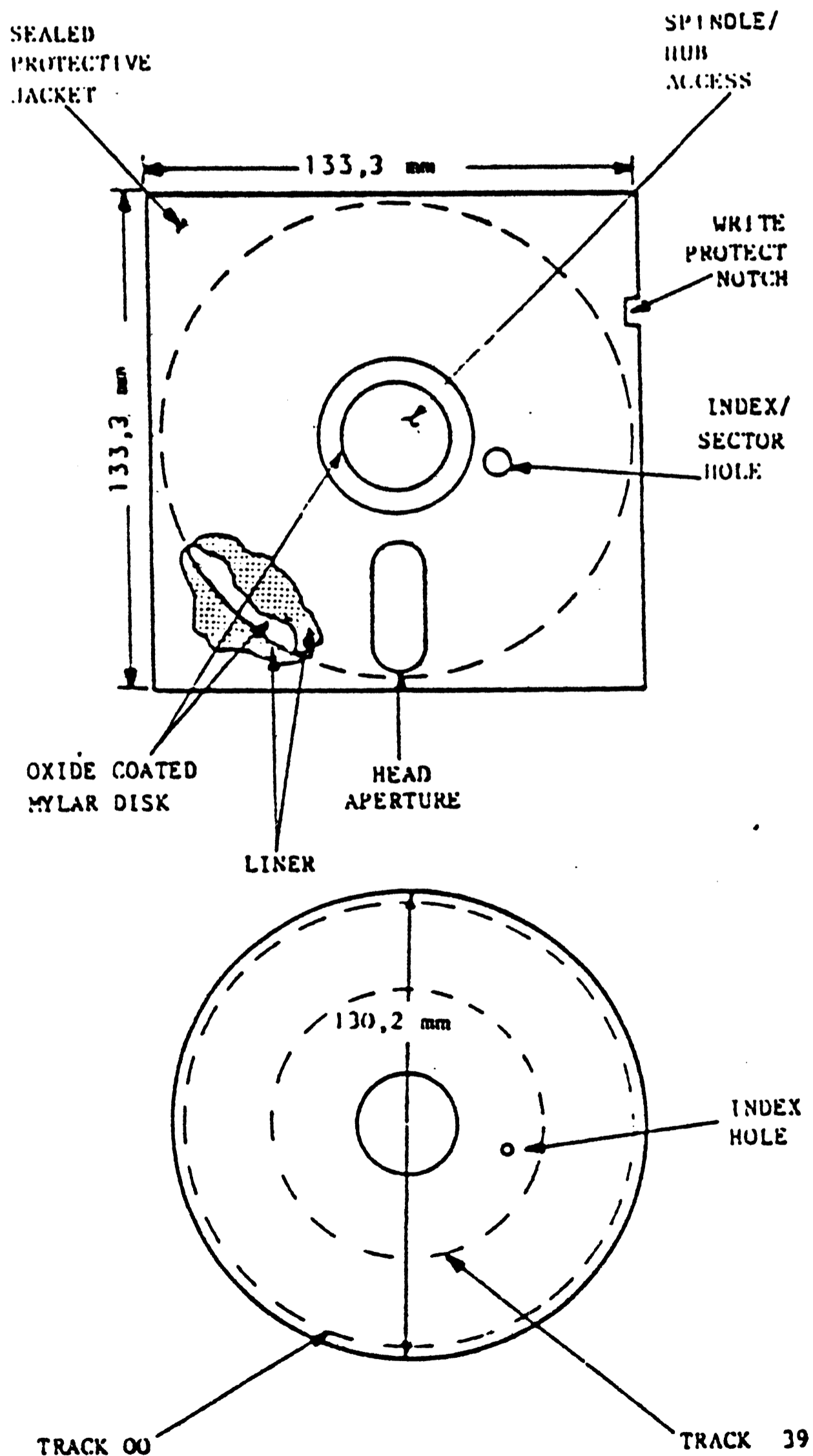

FIG. 1 - 2 FLEXIBLE DISK CONSTRUCTION AND DIMENSIONS

1.7 RECORDING FORMATS

The format of the data recorded on the diskette depends on the host system. There are two encoding schemes used:

- FM (Frequency Modulation) for single density
- MFM (Modified Frequency Modulation) for double density.

1.7.1 FM-ENCODING

This scheme utilizes clocks to define bit cell times. The presence of a flux reversal between clock pulses is defined as a "one" bit. The absence of a flux reversal between clocks is defined as a "zero" bit. On the write data and read data interface lines between disk drive and host system every pulse represents a flux reversal on the diskette.

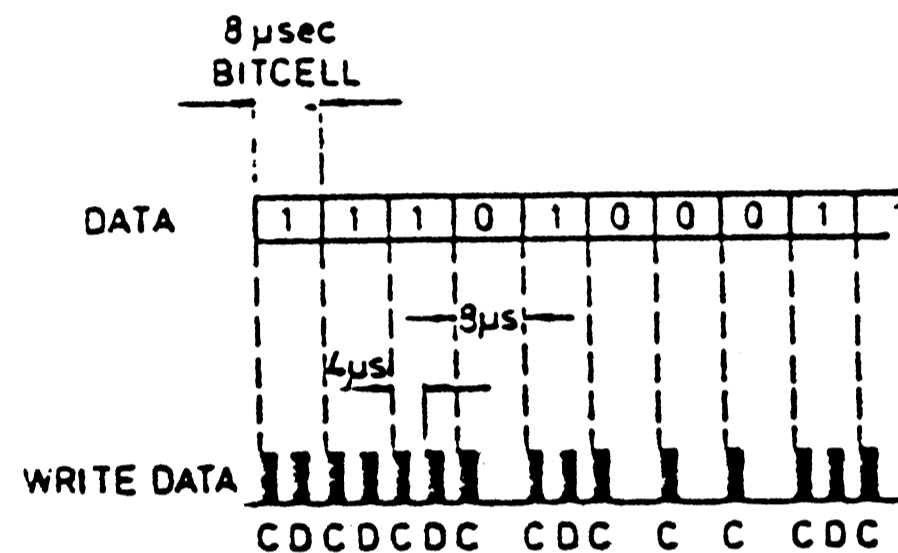

FIG. 1 - 3 FM-ENCODING

1.7.2 MFM-ENCODING

A flux transition is always recorded at the center of the bitcell for each "one" data bit. No flux transition is recorded for a "zero" bit unless it is not followed by another "zero" bit. In this case the flux transition is provided at the end of the first bit cell.

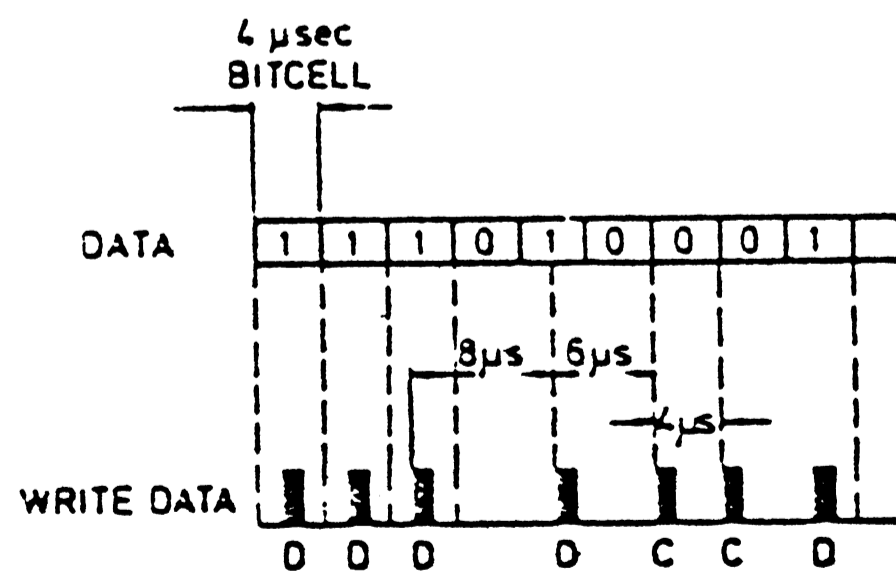

FIG. 1 - 4 MFM-ENCODING

1.8 TRACK FORMAT

The tracks of the Flexy Disk may be formatted in numerous ways, depending on the formatter of the host system used. The BASF mini disk drives write and read hard or soft sectored track formats.

1.8.1 SOFT SECTORED TRACK FORMATS

In a soft sectored track format the user may record one long record or several smaller records on a track. The most common soft sectored track formats are described in the following chapters.

(The designer should also consider national and international standards for data interchange).

1.8.1.1 SOFT SECTORED TRACK FORMAT FOR SINGLE DENSITY (16 sectors/track à 128 bytes)

This format is shown in Fig. 1-6. It is similar to the IBM-format.

The beginning of a track is indicated by a physical index pulse. Every record is preceded by a unique record identifier. Record identifiers and data fields are separated by gaps. The gaps are necessary to allow updating of a data field without disturbing adjacent fields.

INDEX GAP

This gap starts with the index pulse and is 16 bytes in length. It is not affected by any update write process.

IDENTIFIER GAP

This gap consists of 11 bytes FF and may vary slightly in length after the data field has been updated.

DATA GAP

This gap separates the data field from the following ID-field and is nominally 27 bytes in length. It will vary slightly in length after the data field has been updated.

TRACK GAP

The gap between the last data field and the index pulse is defined as Track Gap. It varies slightly in length, due to write frequency and disk speed tolerances. It is nominally 101 bytes in length.

ADDRESS MARK (AM)-BYTE

The soft sectored track format needs unique bit patterns to identify the beginning of ID and Data Fields for synchronizing the deserializer circuit in the host system. The unique bit pattern is called Address Mark (AM). AM-patterns do not contain clock bits in all bit cells (all other data bytes must have clock bits in every bit cell!).

There are three different AM-patterns used:

- ID-AM in front of an ID-Field
- DATA-AM in front of a Data Field
- DELETED DATA-AM in front of a Deleted Data Field

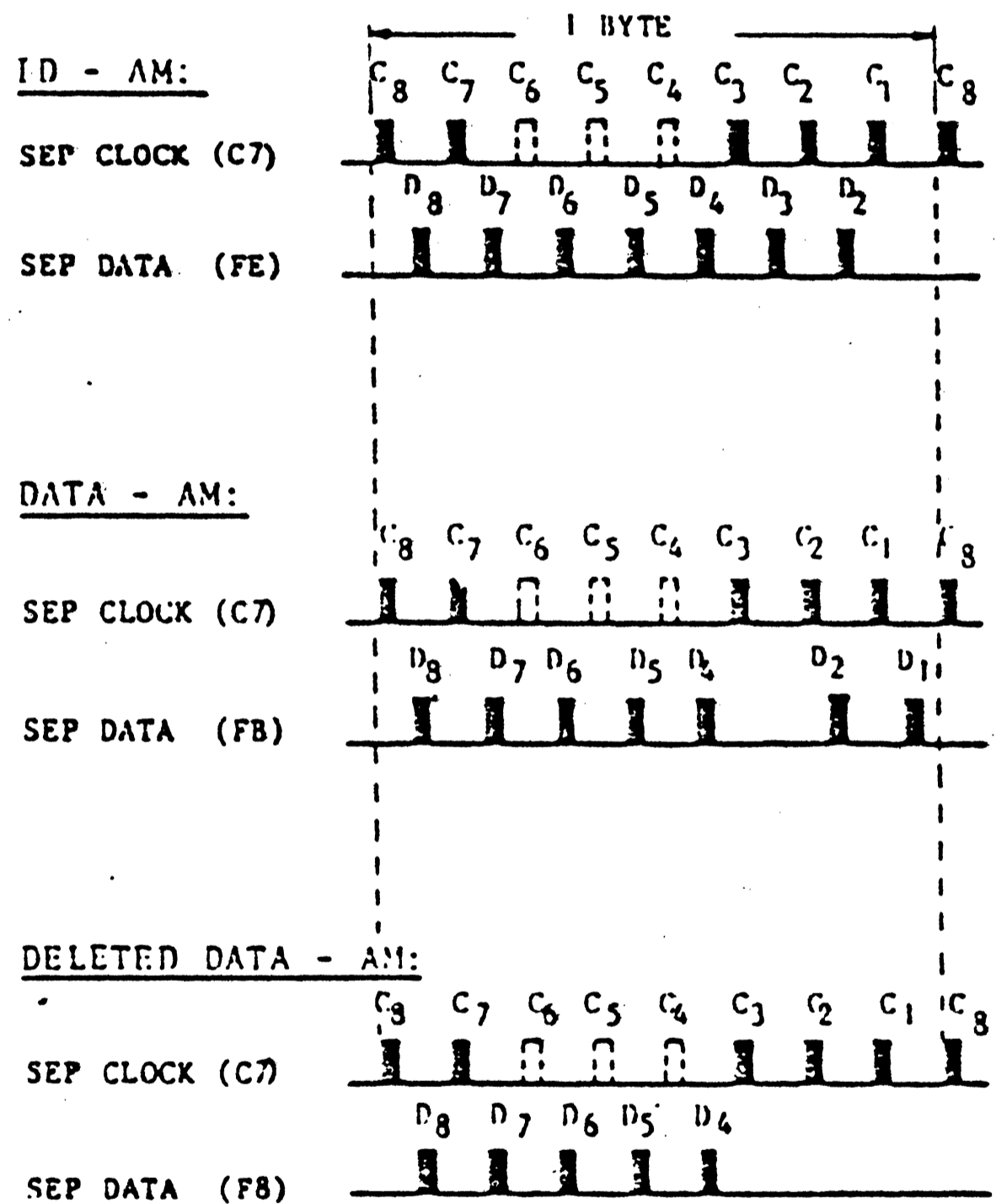

FIG. 1 - 5 ADDRESS MARK PATTERNS

SECTOR IDENTIFIER

The sector identifier consists of the identifier mark, the address identifier and the EDC pattern.

IDENTIFIER MARK

This field comprises 7 bytes (see Fig. 1-6). The 6 bytes of zeros in front of the address mark byte are for synchronisation of the data separator in the host system. The ID-AM-byte contains a data pattern of FE where the clock bits C6, C5 and C4 are missing as explained before.

ADDRESS IDENTIFIER

The address identifier comprises the following 6 bytes:

TRACK ADDRESS (TRK)

This byte represents in binary notation the track address from 00 for the outermost track to 39 for the innermost track.

SIDE ADDRESS (SID)

Represents in binary notation the side address (00 or 01) of the mini disk.

SECTOR ADDRESS (SEC)

Represents in binary notation the sector address from 01 for the 1st sector to 16 for the last sector of a track.

SECTOR LENGTH (LEN)

This byte identifies the length of the data field as follows:

- 00: 128 bytes
- 01: 256 bytes
- 02: 512 bytes
- 03: 1024 bytes

EDC-BYTES (EDC)

These two bytes are hardware generated from the host system by shifting serially the bits of the sector identifier starting with the ID-AM and ending with the 4th byte of the sector identifier through a 16-bit shift register described by the generator polynomial:

$$x^{16} + x^{12} + x^5 + 1.$$

(For more details read chapter EDC-implementation!)

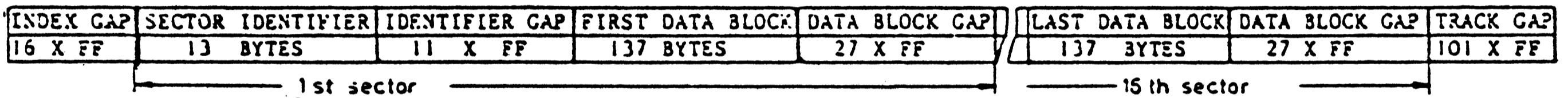

SECTOR IDENTIFIER:

IDENTIFIER MARK	ADDRESS IDENTIFIER				E D C	
6 X 00	FE 1)	TRK	SID	SEC	LEN	2 BYTES
	C7 2)					

ID-AM

DATA BLOCK:

DATA	MARK	DATA FIELD	E D C
6 X 00	FB 1)	128 BYTES	2 BYTES
	C7 2)		

DATA-AM

- 1) DATA PATTERN
- 2) CLOCK PATTERN
- DELETED AM : 78

ID - AM:

SEP CLOCK (C7)

SEP DATA (FE)

DATA - AM:

SEP CLOCK (C7)

SEP DATA (FB)

DELETED DATA - AM:

SEP CLOCK (C7)

SEP DATA (F8)

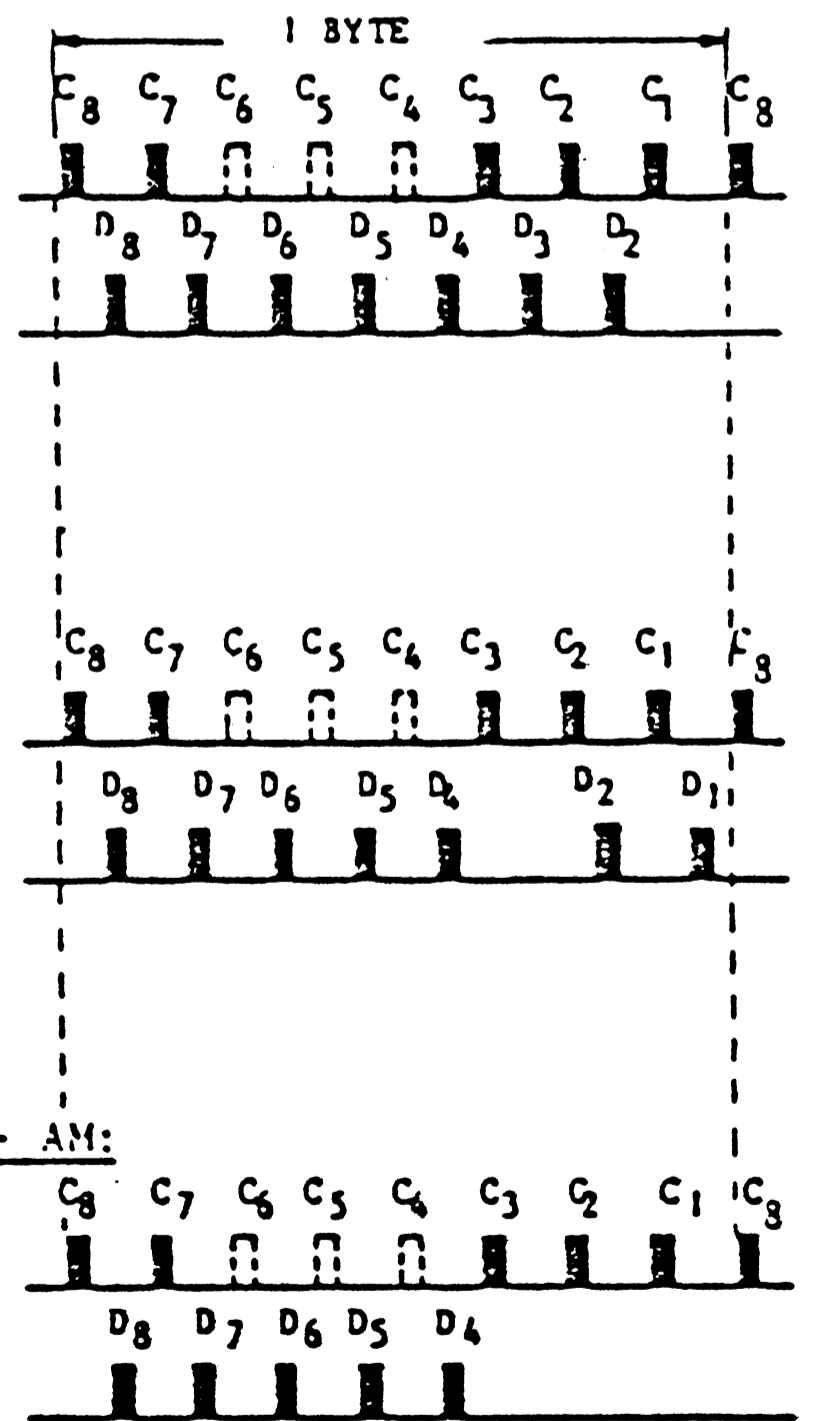

FIGURE 1 - 6 SOFT SECTORED TRACK FORMAT WITH 16 SECTORS/TRACK FOR SINGLE DENSITY (FM)

DATA BLOCK

The data block contains the data mark, the data field and the EDC-bytes.

DATA MARK

This field comprises 7 bytes (see Fig. 1-6). The 6 bytes of zeros in front of the data address mark are for synchronisation of the data separator circuit in the host system. The data address mark byte contains F8 in front of a normal data field. When a deleted data field follows, F8 must be written. The clock pattern of the data address mark is C7 (C6, C5 and C4 missing).

DATA FIELD

This field comprises 128 bytes. If it comprises less than 128 bytes, the remaining positions shall be filled with zeros.

EDC-BYTES

These two bytes are hardware generated by the host system by shifting serially the bits of the data block starting with the Data-AM and ending with the last byte of the data field

through a 16-bit shift register described by the following generator polynomial:

$$x^{16} + x^{12} + x^5 + 1$$

EDC-IMPLEMENTATION

Fig. 1-7 is a simplified logic of a shift register, which may be used to generate the EDC bytes.

Prior to the operation, all positions of the shift register are set to ONE. Input data are added (exclusive OR) to the contents of position C_{15} of the register to form a feedback. This feedback in turn is added (exclusive OR) to the contents of position C_4 and position C_{11} .

On shifting, the outputs of the exclusive OR gates are entered into positions C_0 , C_5 and C_{12} respectively. After the last data bit was added, the register is shifted once more as specified above.

The register then contains the EDC bytes. When further shifting is to take place during the writing of the EDC bytes, the control signal inhibits exclusive OR operations.

To check for errors when reading, the data bits are added into the shift register in exactly the same manner as they were during writing. After the data the EDC bytes are also entered into the shift register as if they were data. After the final shift, the register contents will be all ZERO if the record does not contain errors.

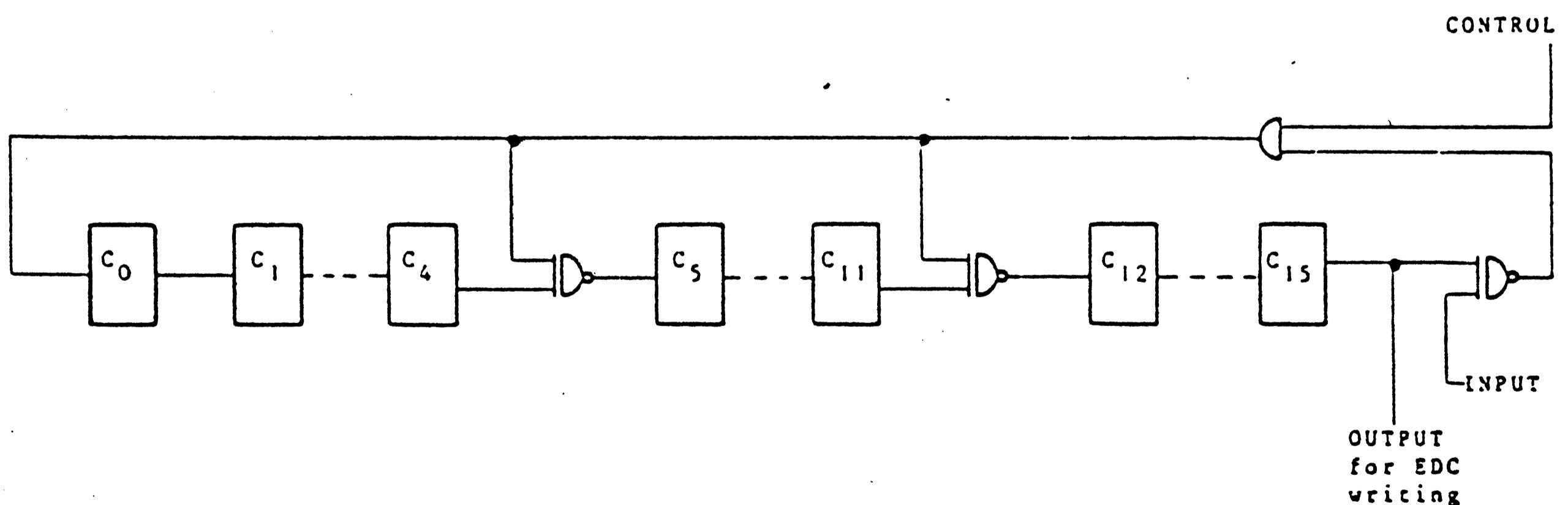

FIGURE 1 - 7 SIMPLIFIED EDC SHIFT REGISTER

1.8.1.2 SOFT SECTORED TRACK FORMAT FOR SINGLE DENSITY (9 SECTORS/TRACK @ 256 BYTES)

In this format, which is shown in Fig. 1-8, each sector contains 256 bytes.

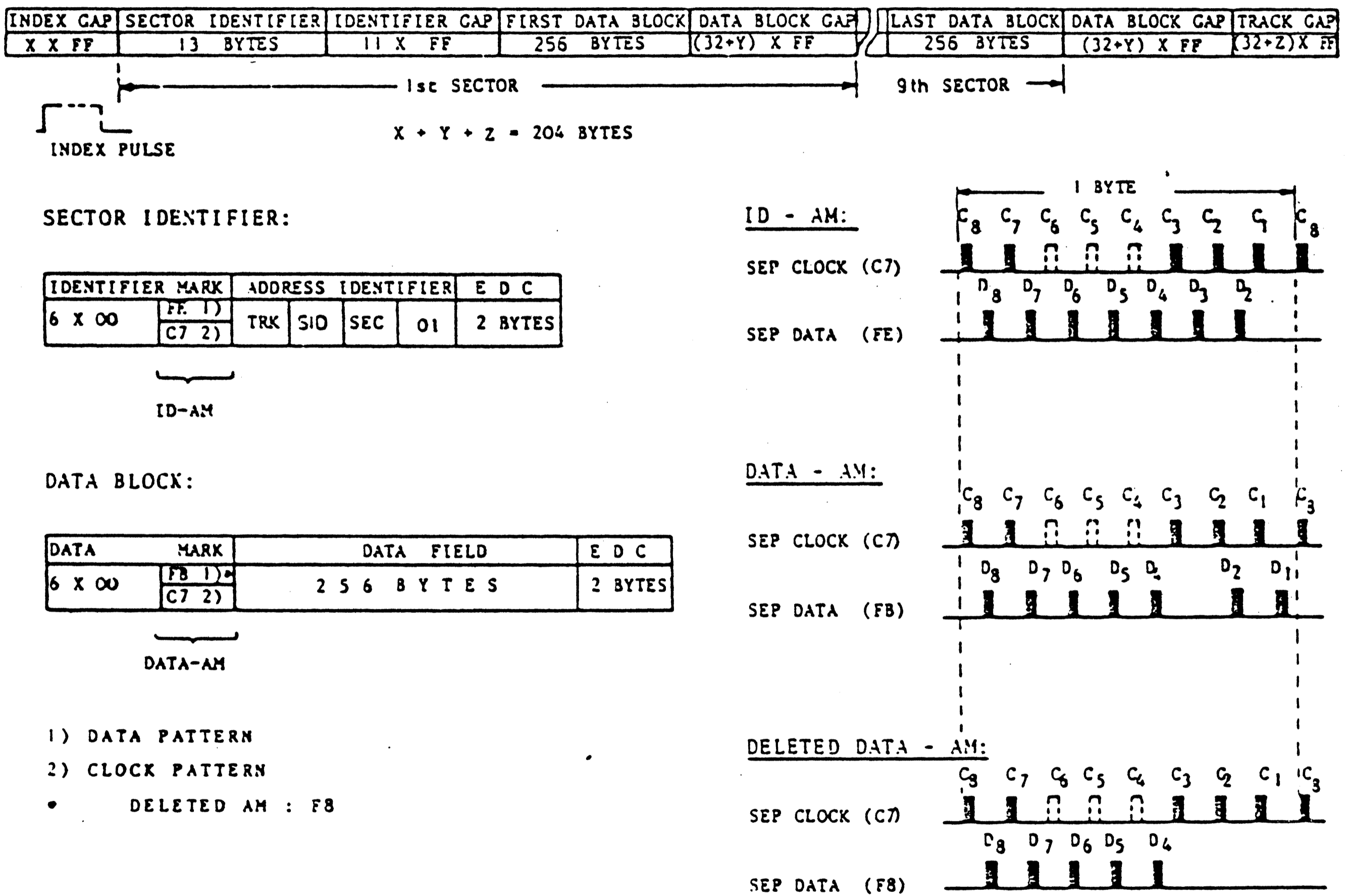

FIGURE 1 - 8 SOFT SECTORED TRACK FORMAT WITH 9 SECTORS/TRACK

1.8.1.3 SOFT SECTORED FORMAT FOR DOUBLE DENSITY
(16 Sectors à 256 bytes)

On double sided diskettes for double density track 0 on side 0 is recorded in FM. For this track only the previous described track format for single density is valid. All other tracks on the diskette are recorded in MFM. For these tracks the following track format will be valid (see Fig. 1-9).

The content of the data blocks is doubled to 256 bytes. In MFM recording the bit density is also doubled, the sector count will be the same as in single density format (1.8.1.1). The meaning of the different fields and the generation of the EDC-bytes are the same as in single density recording. Only the address mark pattern is changed as shown in Fig. 1-9.

INDEX GAP	SECTOR IDENTIFIER	IDENTIFIER GAP	FIRST DATA BLOCK	DATA BLOCK GAP	LAST DATA BLOCK	DATA BLOCK GAP	TRACK GAP
146 BYTES	22 BYTES	22 x 4E	274 BYTES	54 x 4E	262 BYTES	54 x 4E	192 x 4E

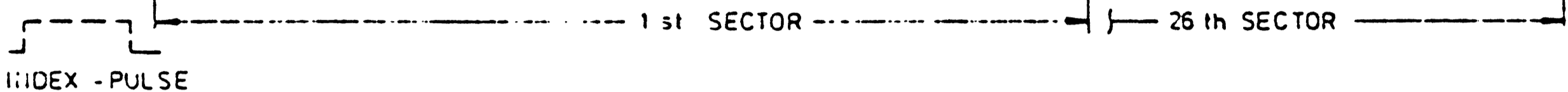

INDEX - PULSE

INDEX GAP

90 x 4E	12 x 00	3 x C2 1)	FC	50 x 4E
---------	---------	-----------	----	---------

1) MISSING CLOCK TRANSITIONS BETWEEN BITS 5 AND 4.

INDEX - AM

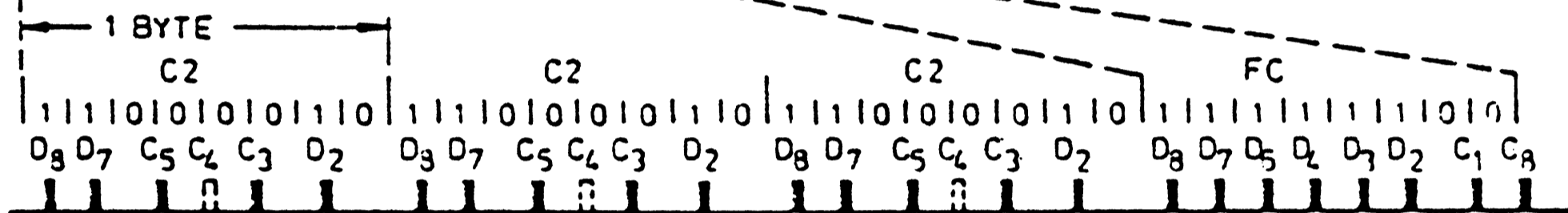

SECTOR IDENTIFIER

IDENTIFIER MARK	ADDRESS IDENTIFIER	EDC
12 x 00	3 x A1 2)	FE
	CYL	SID
	SEC	01
		7 BYTES

2) MISSING CLOCK TRANSITIONS BETWEEN BITS 4 AND 3.

ID - AM

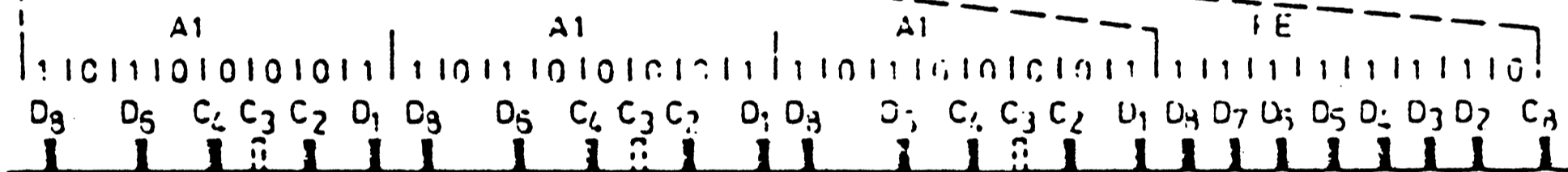

DATA BLOCK

DATA MARK	DATA FIELD	EDC
12 x 00	256 BYTES	2 BYTES
3 x A1 2)		FB 3)

2) MISSING CLOCK TRANSITIONS BETWEEN BITS 4 AND 3.

3) DELETED RECORD FB

DATA - AM

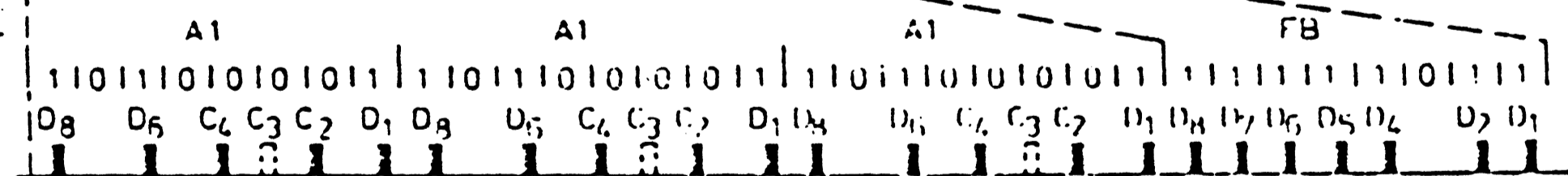

DELETED DATA - AM

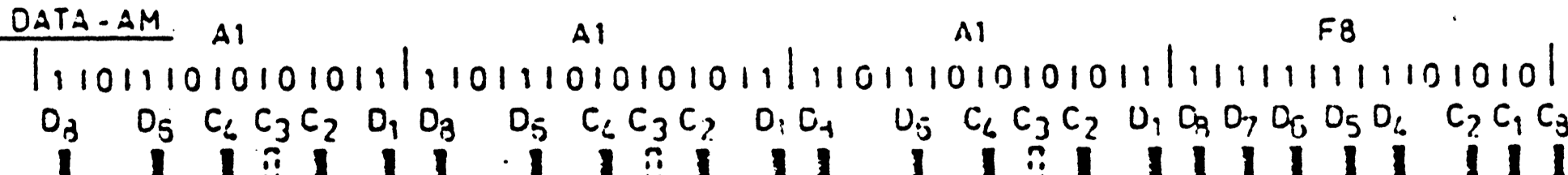

FIGURE 1 - 9 SOFT SECTORED TRACK FORMAT FOR DOUBLE DENSITY (MFM)

2.1 FUNCTIONAL DESCRIPTION

The models 6106 and 6108 comprise the following mechanisms and functional circuits (see Fig. 2 - 1).

Mechanisms:

- Drive Mechanism
- Spindle and Front Door Mechanism
- Positioning Mechanism
- Head Load Mechanism

Functional Circuits:

- Interface
- Drive Motor Control
- HEAD LOAD-, DOOR LOCK- and ACTIVITY LED- Driver
- Track Zero Detector
- Write Protect Detector
- Index / Ready Detector
- Read / Write Circuits
- DC- Control and Power On Reset LOGIC
- SIDE SELECT LOGIC

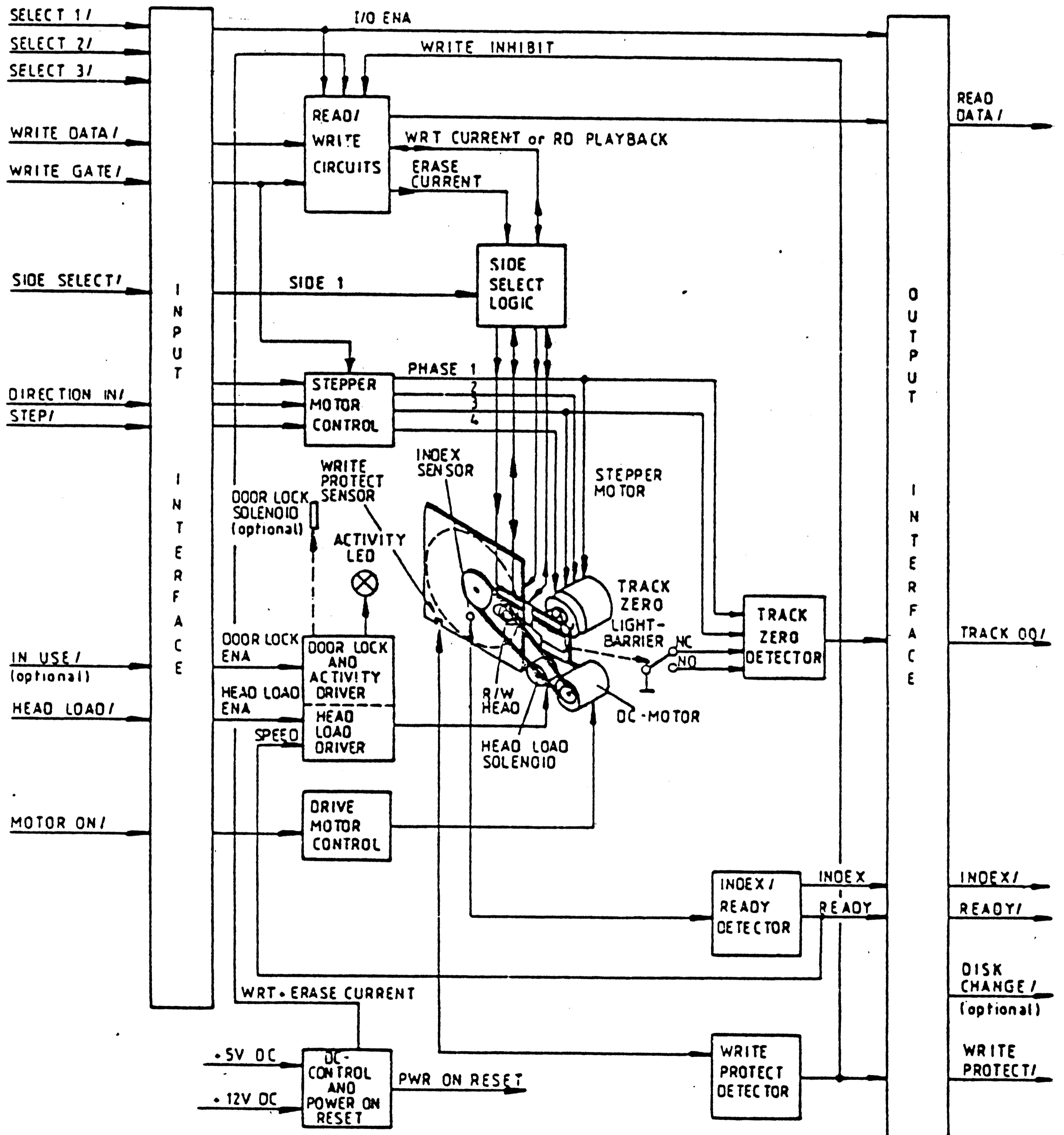

FIGURE 2 - 1 BLOCK DIAGRAM BASF 6106/6108

2.1.1 DRIVE MECHANISM

The spindle is rotated at 300 rpm by a DC drive motor. Rotation of the spindle is provided by a belt and pulley. The drive motor is started and stopped by the interface signal MOTOR ON. The ratio between motor and spindle speed is approximately 7:1. The drive mechanism is shown in Fig. 2 - 2.

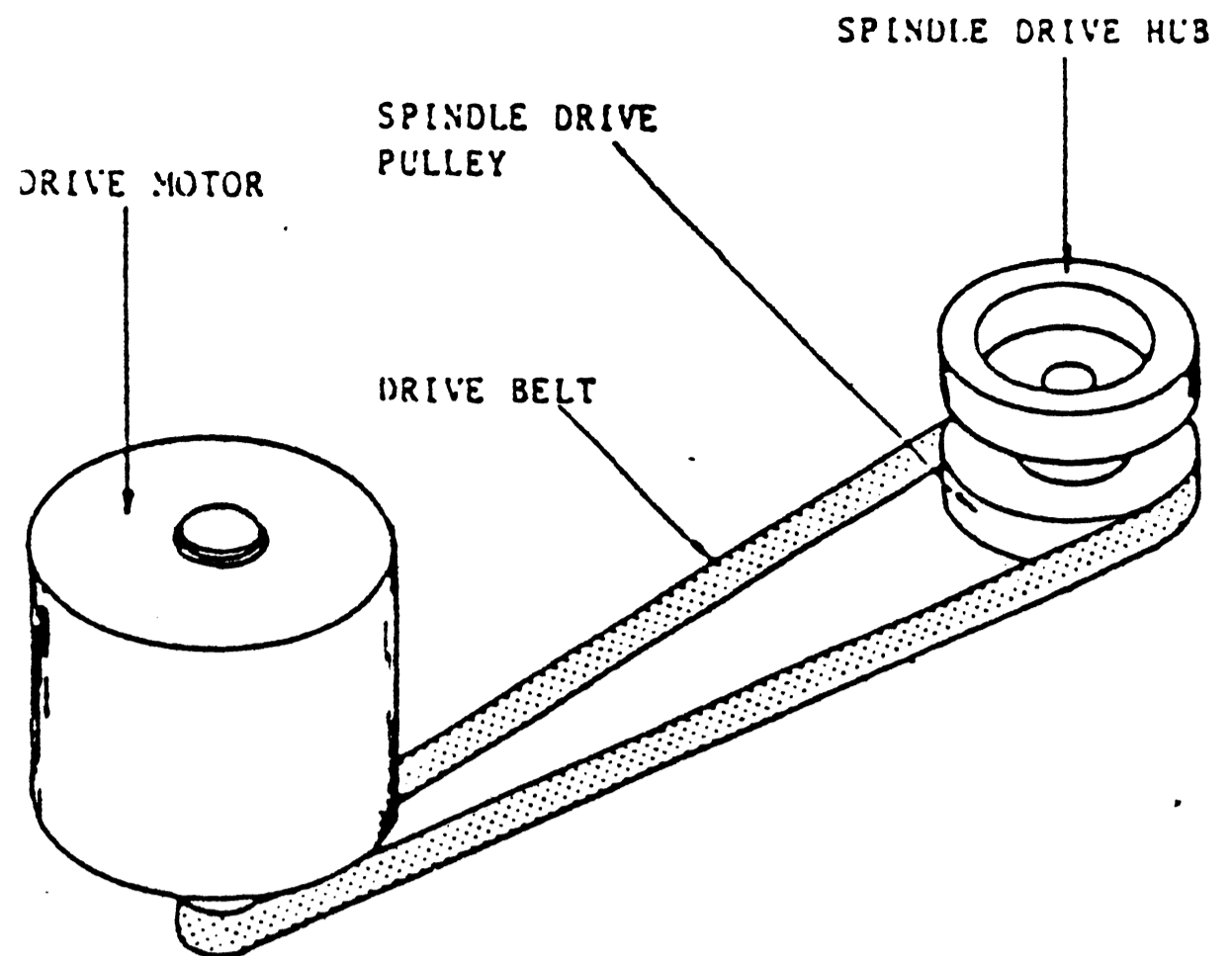
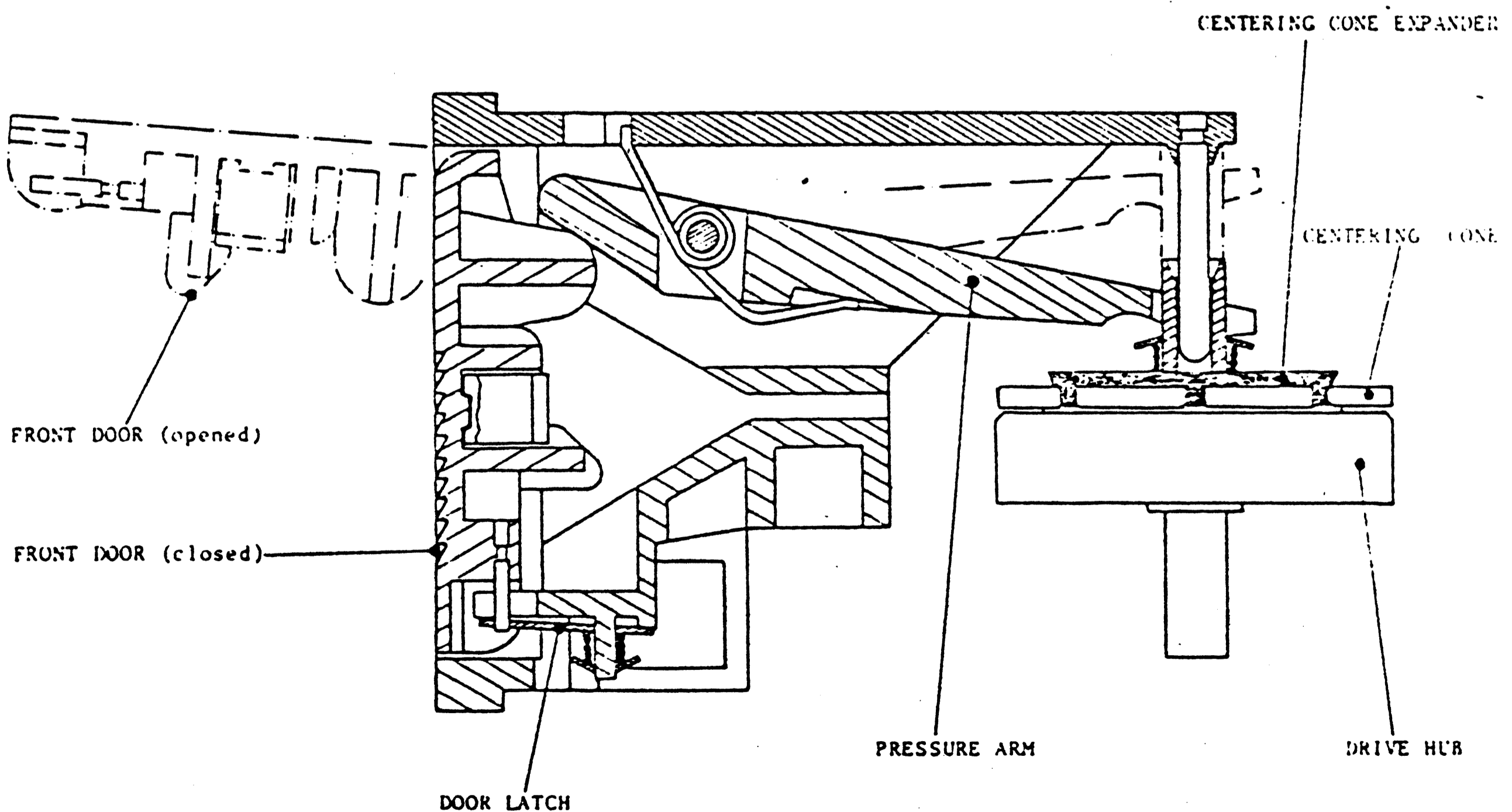

FIGURE 2 - 2 DRIVE MECHANISM

2.1.2 SPINDLE AND FRONT DOOR MECHANISM

The main parts of this mechanism are the drive hub, the centering cone, the centering cone expander and the front door with pressure arm and door latch (see Fig. 2 - 3). For loading, a diskette is inserted and the front door pressed. The pressure arm moves down, the centering cone enters the Flexy Disk. Just before the centering cone reaches the full down position, the centering cone expander is

activated and expands the centering cone which grips the inner diameter of the Flexy Disk to ensure correct alignment. The door latch is activated and holds the front door in a closed position. For unloading a disk, the front door must be pressed again. The door latch opens and the pressure arm is moved upwards by a spring. The centering cone and centering cone expander also move upwards and disengage the mini disk from the drive hub.



2.1.3 POSITIONING MECHANISM

The main parts of the positioning mechanism are (see Fig. 2 - 4):

- Stepper Motor
- Spiral Wheel
- Carriage Assembly

The stepper motor is a four phase motor and is rotated 15° by every step pulse. The spiral wheel directly connected to the shaft of the stepper motor converts the rotational motion of the stepper motor to a linear motion of the read write head assembly.

The BASF 6106 carriage assembly (Fig. 2 - 4a) consists of the read/write head, and the head load pressure arm. The read/write head is inserted in the carriage assembly, which rides on two guide bars. The Flexy Disk is pressed against the read/write head by the head load pressure arm. The head load pressure arm is released by the head load mechanism.

In the BASF 6108 carriage assembly (Fig. 2 - 4b) the head load pressure pad is replaced by the upper read/write head.

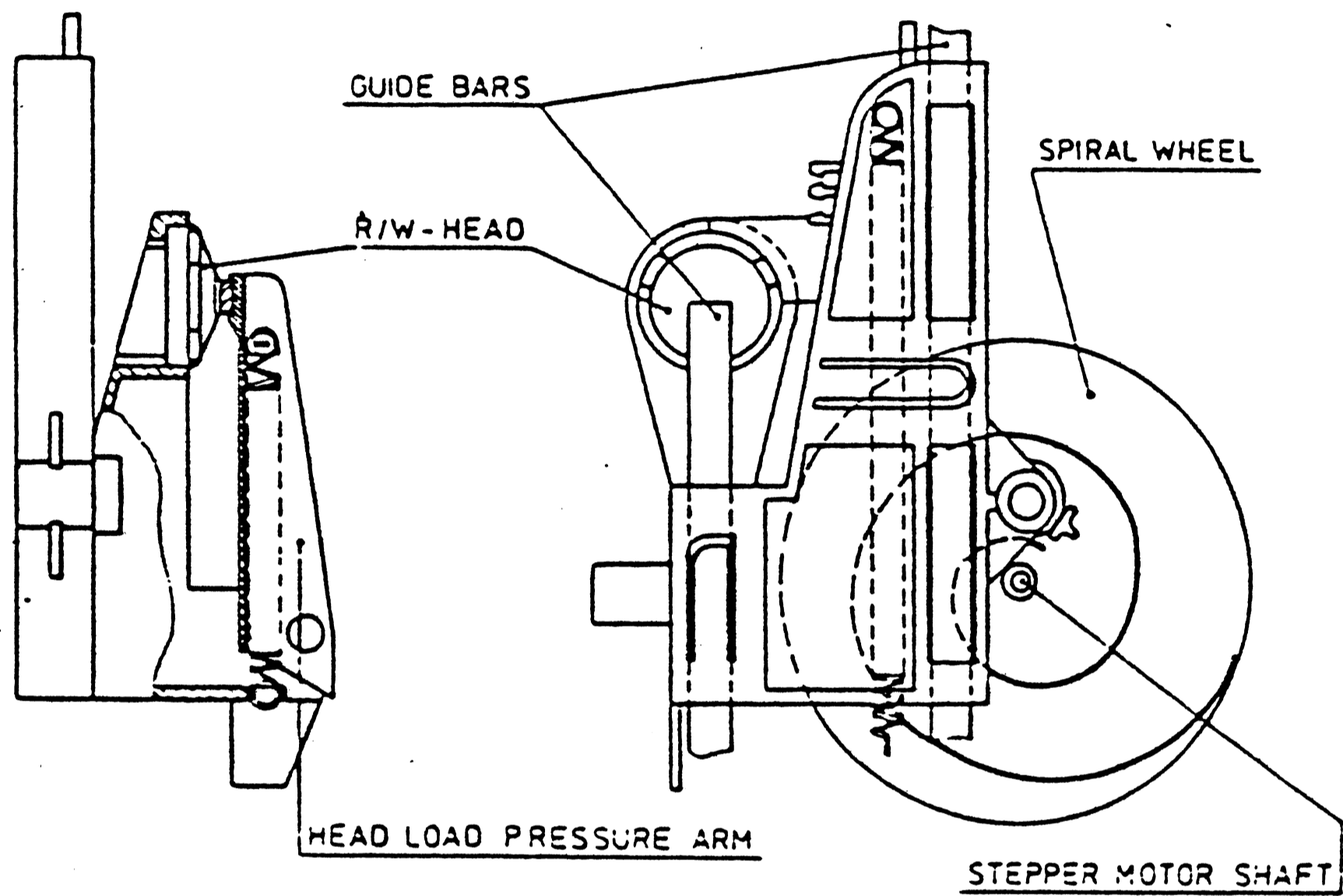

FIGURE 2 - 4 a) POSITIONING MECHANISM BASF 6106

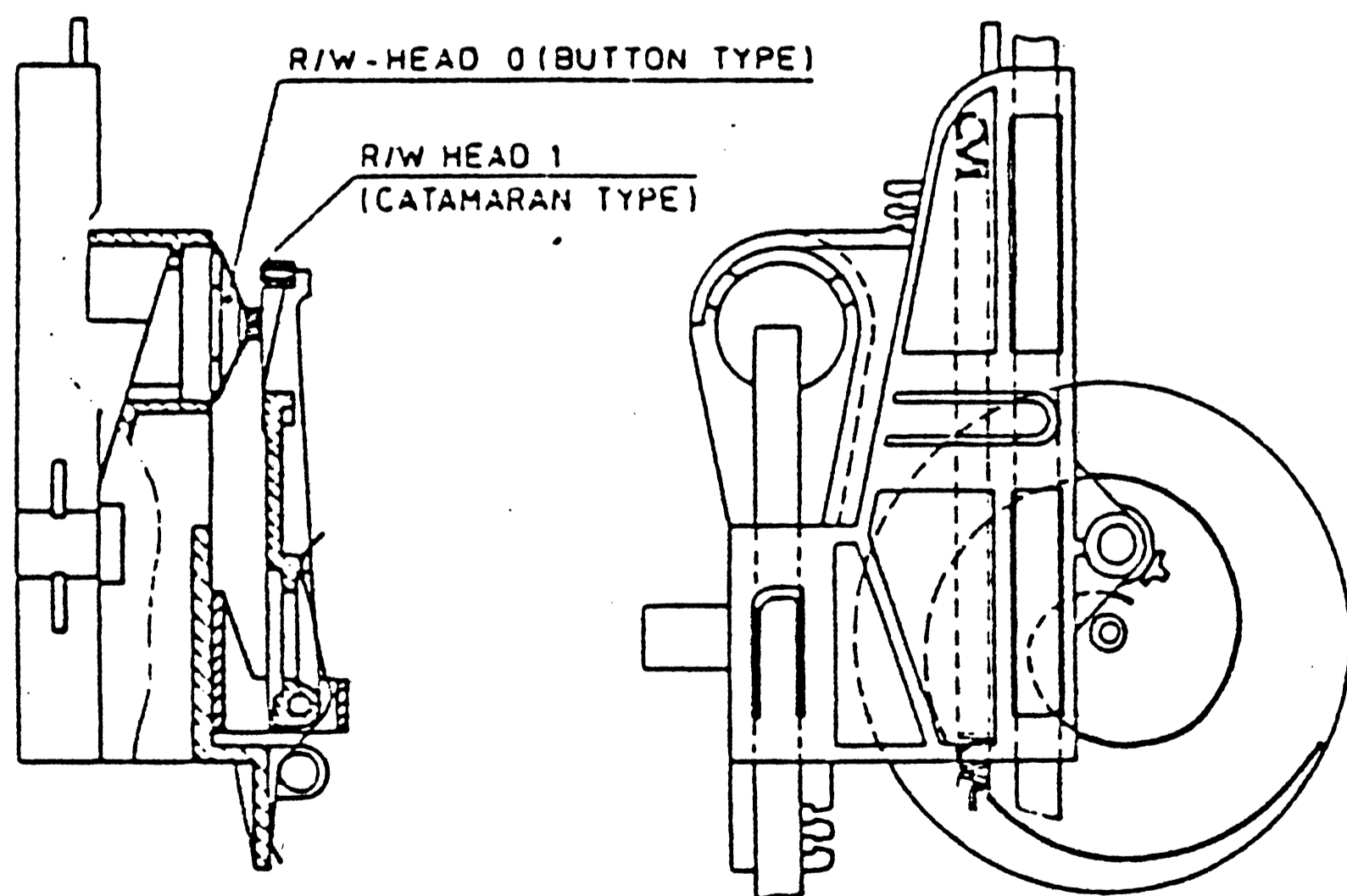

FIGURE 2 - 4b) POSITIONING MECHANISM BASF 6108

2.1.4 HEAD LOAD MECHANISM

The head load mechanism comprises (see Fig. 2 - 5):

- Head Load Solenoid
- Head Load Actuator

When the head load solenoid is energized, the head load actuator releases the head load pressure arm of the carriage assembly. On the single sided mini disk drive (BASF 6106) this causes the mini disk to be pressed against the read/write head by the head load pad. On the double sided mini disk drive (BASF 6108) the Flexy Disk is pressed against the bottom head (HEAD 0) by the upper head (HEAD 1) mounted in the pressure arm. The pressure foam on the head load actuator stabilizes the Flexy Disk. When the head load solenoid is deenergized, the head load actuator is lifted by a spring. The head load pressure arm is lifted also.

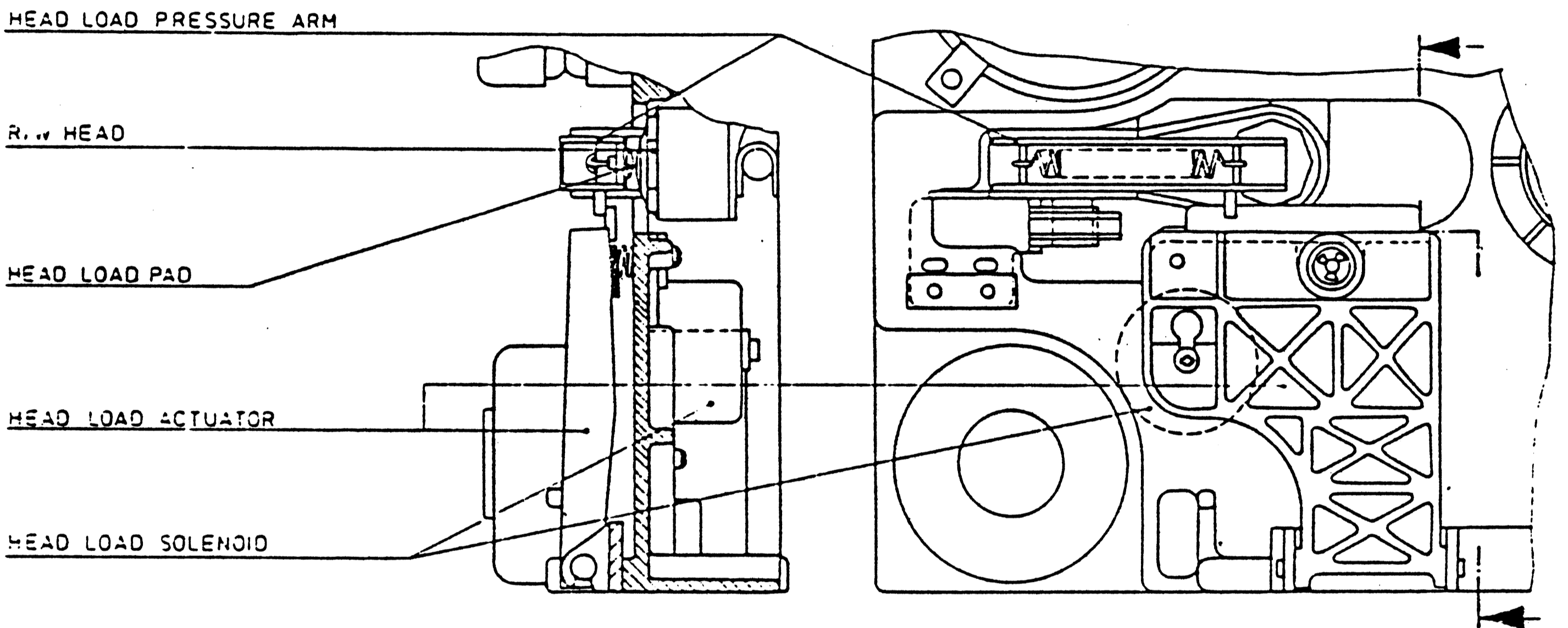

FIGURE 2 - 5a) HEAD LOAD MECHANISM BASF 6106

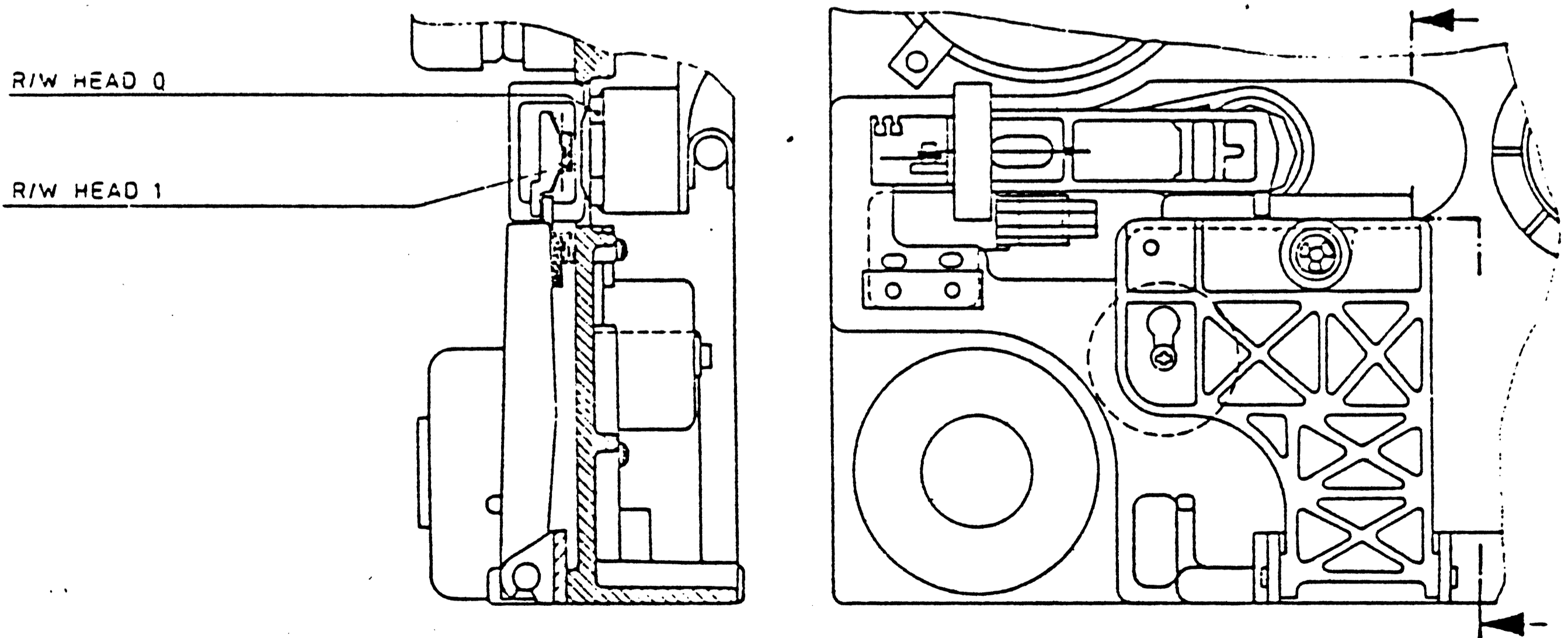

FIGURE 2 - 5b) HEAD LOAD MECHANISM BASF 6108

2.2 LOGIC DESCRIPTION

2.2.1 INTERFACE LOGIC

The interface logic consists of two parts
(see Fig. 2 - 6):

- the input interface
- the output interface

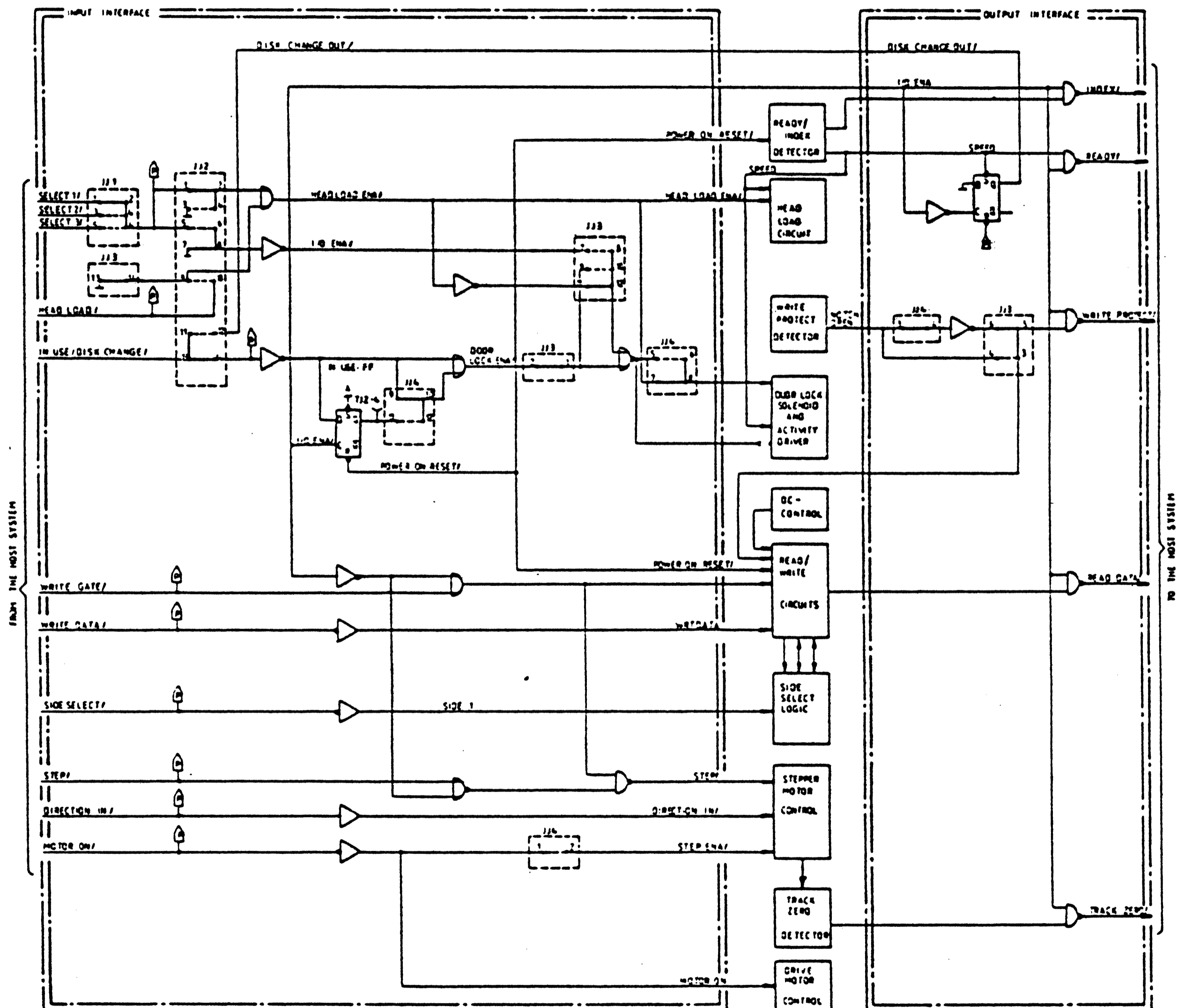

FIGURE 2 - 6 INTERFACE LOGIC

2.2.1.1 INPUT INTERFACE

The input interface receives the signals from the host system. Table 2-1 lists and defines the input signals.

The input lines are terminated by pull up resistors of 150 Ohm. In a serial configuration only the last drive will contain the pull up resistor network.

The receivers send the input signals to the different parts of the drive electronics.

SIGNAL NAME	DEFINITION
SELECT (1-3) /	Selects the desired mini disk drive. Enables all other interface lines except MOTOR ON, WRITE DATA, SIDE SELECT and DIRECTION IN.
WRITE DATA/	This line carries low active pulses representing data to be recorded on the mini disk. 
WRITE GATE/	Low input enables recording of WRITE DATA on disk. High input enables reading from the Flexy Disk.
MOTOR ON/	This line turns on the drive motor and the stepper motor and is not gated by SELECT. A recalibrate operation must be performed to obtain correct head positioning every time after the MOTOR ON signal goes active. Switching of the stepper motor may be disabled by removing a jumper. This avoids recalibrating after switching on the drive motor.
DIRECTION IN/	Defines motion of the read/write head LOW = in (towards Track 39) HIGH = out (towards Track 0) This line is not gated by SELECT.
STEP/	Used in conjunction with DIRECTION IN and causes the read/write head to be moved from track to track.
HEAD LOAD/	This line is used to press the mini disk against the read/write head if the mini disk drive is ready. To activate this line a jumper has to be changed.
IN USE/	This line controls the door lock solenoid. Also the activity LED can be switched on. If the IN USE/ signal is used, the disk change option must be disabled.
SIDE SELECT/	This line defines whether head 0 or head 1 of the mini disk drive is used. A high signal selects head 0, a low signal selects head 1. This line is not gated by SELECT. On BASF 6106 head 1 is not installed.

TABLE 2 - 1 INPUT SIGNALS

2.2.1.2 OUTPUT INTERFACE

The output interface sends the read data pulses and the status signals WRITE PROTECT, INDEX, READY, TRACK 00 and DISK CHANGE (optional) to the host system (see Table 2 - 2).

The output signals are gated by I/O- ENABLE and driven by the output drivers SN 7438.

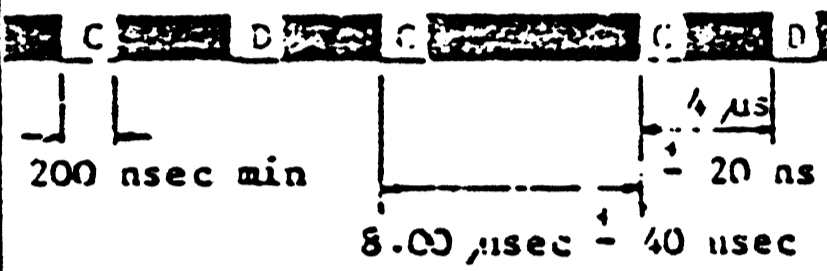
SIGNAL NAME	DEFINITION
READ DATA/	This line provides the "raw data" as detected by the read electronics. 
WRITE PROTECT	Low active status indicates that a write protected Flexy Disk is installed. The BASF 6106/08 will inhibit writing with a write protected Flexy Disk installed.
INDEX/	The leading edge of this signal indicates the beginning of a track when soft sector format is used.  <p>If a hard sectored disk is used this signal indicates the sensing of an index or sector hole. To indicate the beginning of a track one index pulse is sensed in the middle of sector 15.</p> 
TRACK 00/	This line indicates that the read/write head is positioned at track 00.
READY/	This line indicates that the inserted Flexy Disk has reached more than 60 % of full operation speed and three consecutive INDEX pulses have been sensed. For hard sectored Flexy Disks READY is activated as soon as the Flexy Disk starts turning and three consecutive SECTOR pulses have been sensed.
DISK CHANGE/ (OPTION)	An active (low) signal is provided when the SELECT line is activated if the drive while deselected has gone from a Ready to a Not Ready condition.

TABLE 2 - 2 OUTPUT SIGNALS

2.2.1.3 JUMPER OPTIONS

The following options can be selected by Jumpers:

- Select Options
- Head Load Options
- IN USE Options
- Door Lock Latch Option
- Door Lock Options
- Activity LED Option
- Write Protect Option
- Stepper Motor Switching

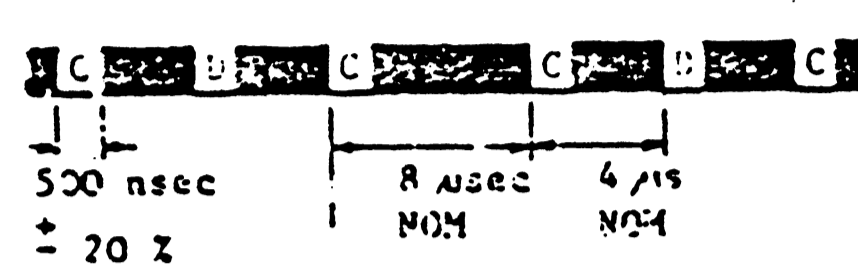
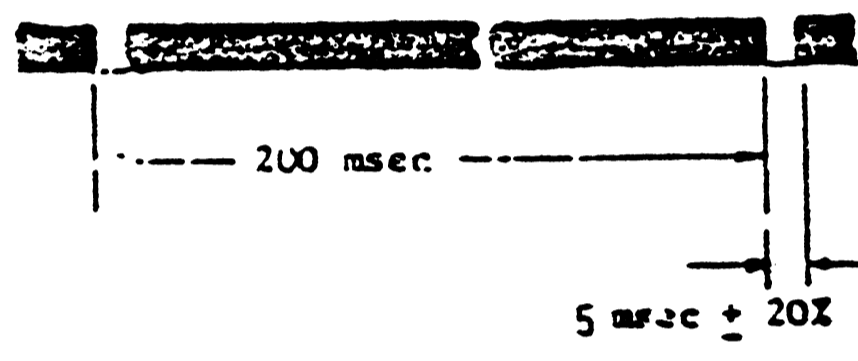
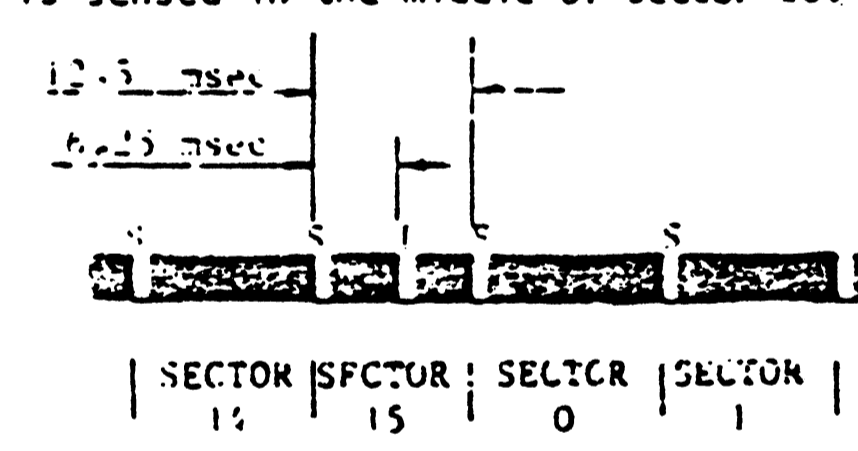
SELECT OPTIONS

There are two possibilities to select the mini disk drive.

- Auto Select
- Radial Select

AUTO SELECT

This option is used when no SELECT lines are used. The input and output interfaces are always enabled, because I/O ENA is forced to a high. To install the AUTO SELECT option, PIN 7 and 8 of JJ2 must be jumpered (see Fig. 2 - 7).

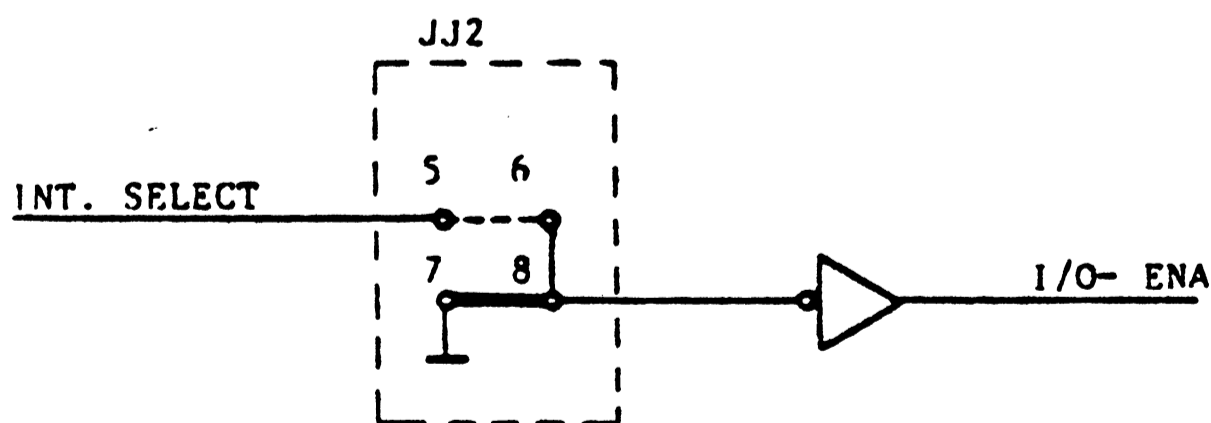

FIGURE 2-7 AUTO SELECT OPTION

RADIAL SELECT

If Radial Select is used a max. of 3 mini disk drives can be connected to the host system. The signal SELECT 1/ will select the mini disk drive jumpered between JJ1 1-2, SELECT 2/ will select the mini disk drive jumpered between JJ1 3-4 and SELECT 3/ will select the mini disk drive jumpered between JJ1 5-6. Only one select jumper is allowed in one drive. For enabling of the Radial Select Option JJ2 5-6 must be jumpered and the Auto Select Option must be disabled by removing jumper JJ2 7-8.

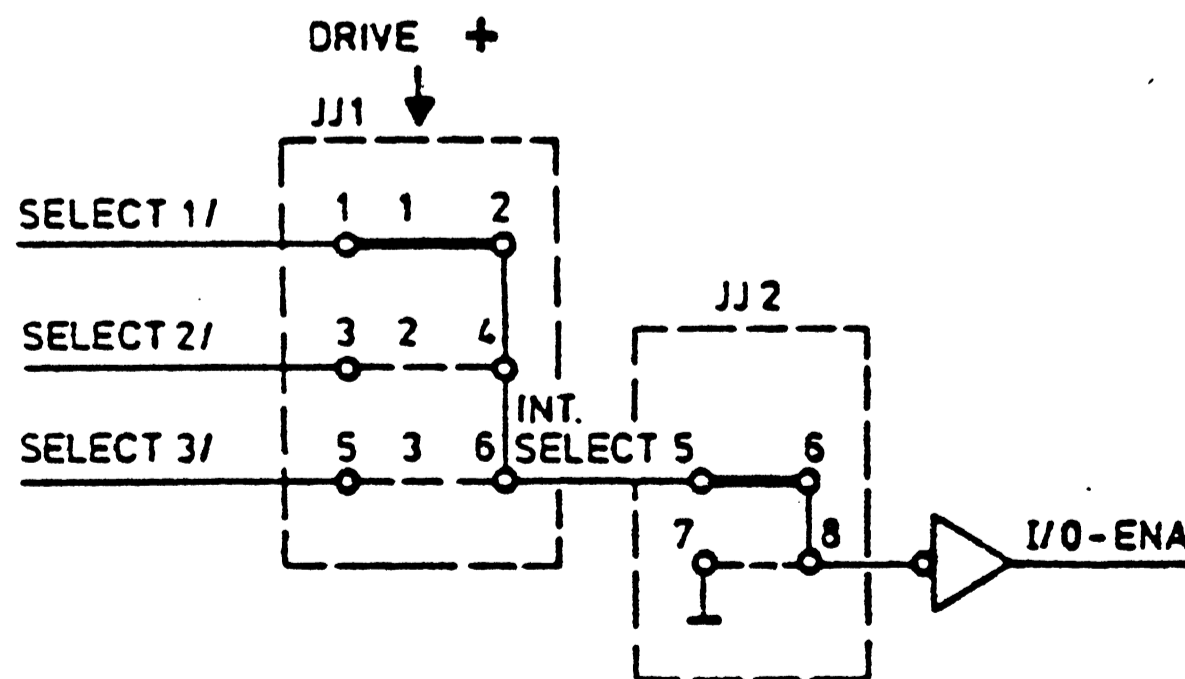

FIGURE 2-8 RADIAL SELECT OPTION

HEAD LOAD OPTIONS

There are three possibilities for the user to load the head:

- Auto Head Load
- Selected Head Load
- Radial Head Load

AUTO HEAD LOAD OPTION

This option allows the read/write head(s) to be loaded as soon as the mini disk drive is selected. If auto head load is desired the jumpers must be set as shown in Fig. 2-9.

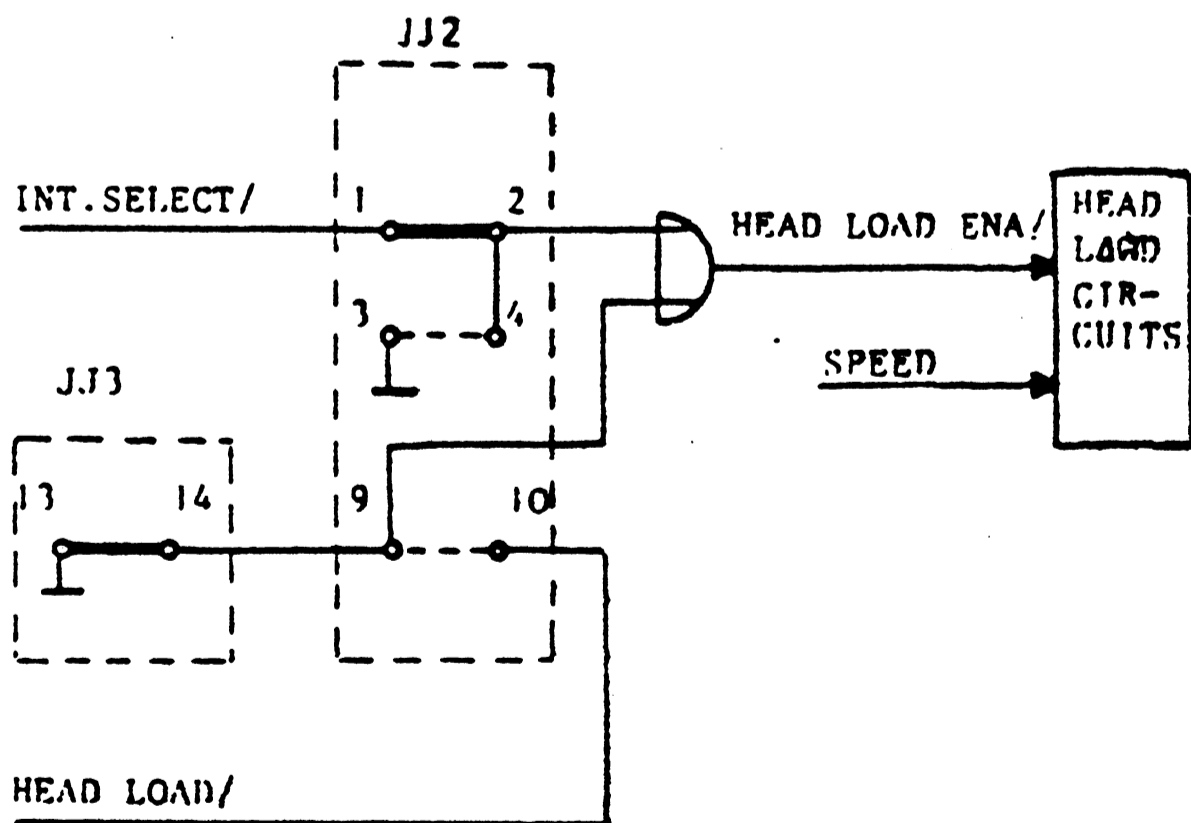

FIG. 2 - 9 AUTO HEAD LOAD OPTION

SELECTED HEAD LOAD OPTION

In this configuration the head is loaded when the mini disk drive is selected and the HEAD LOAD signal is activated (see Fig. 2-10).

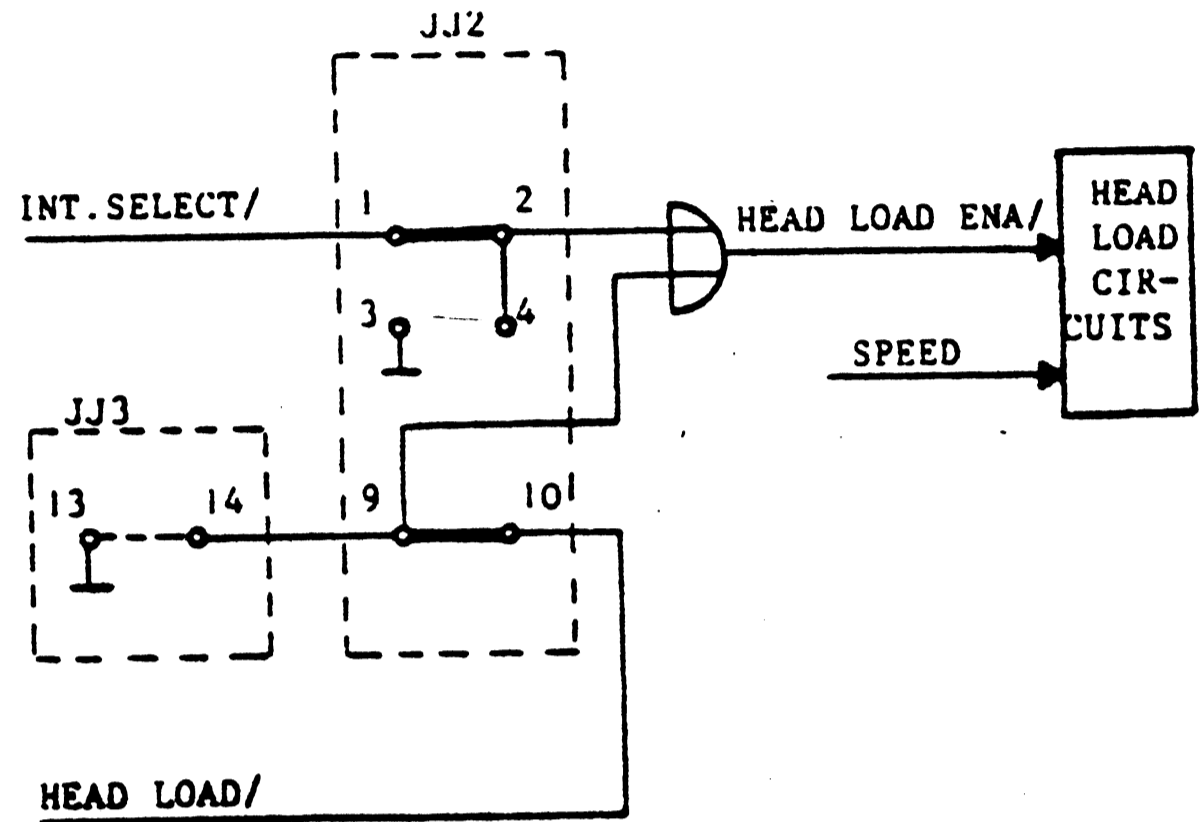

FIG. 2 - 10 SELECTED HEAD LOAD OPTION

RADIAL HEAD LOAD OPTION

This option allows the user to keep the head loaded without selection of the mini disk drive. The 48 msec head settling time is then eliminated. To install this option see Fig. 2-11.

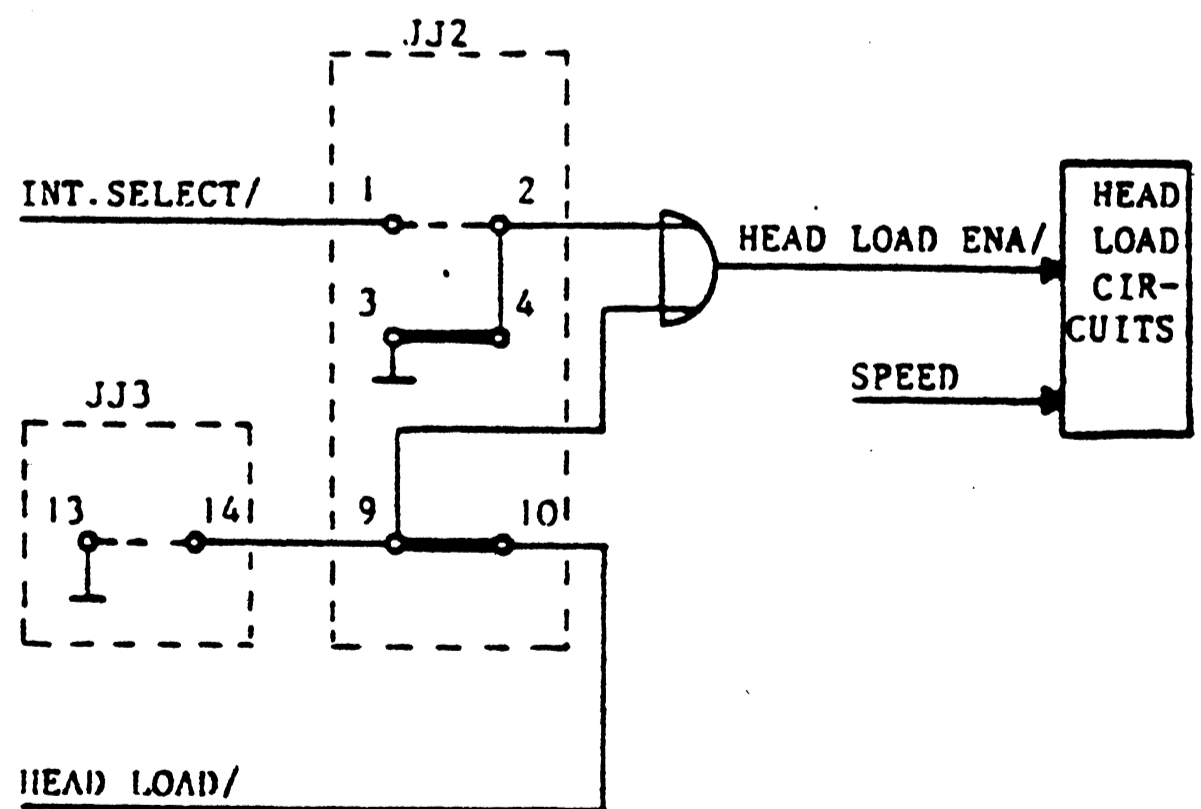

FIG. 2 - 11 RADIAL HEAD LOAD OPTION

DOOR LOCK LATCH OPTION (FIG. 2-12)

This option can be used if the IN USE-option is already installed. Then, the door lock latch option will allow the latching of the door lock solenoid under control of the SELECT and IN USE signals without keeping the IN USE signal active. The IN USE-FF stores the state of the IN USE-signal when the drive is selected (see Fig. 2-13). The door lock solenoid remains activated even if the mini disk drive is deselected and the IN USE-signal is deactivated. To unlock the door, the mini disk drive must be selected again with IN USE inactive (low). To enable the Door Lock Latch Option, a jumper must be installed on JJ2 between Pins 11 and 12.

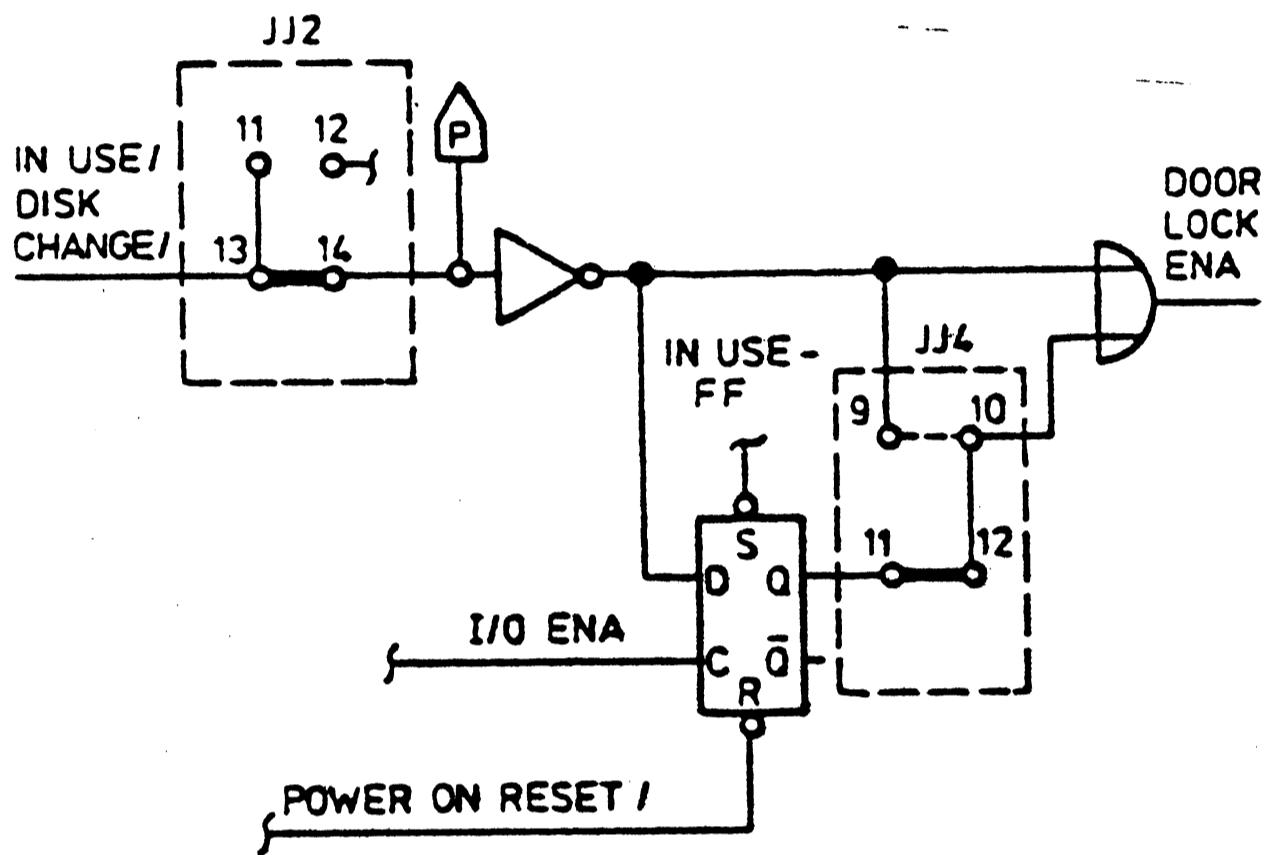

FIG. 2 - 13 DOOR LOCK OPTION

IN USE OPTION

Pin 34 of the interface can be used for the IN USE option if JJ2 is jumpered from Pins 13 to 14. The IN USE-signal is used to turn on the door lock solenoid, also the IN USE-signal can be used to turn on the activity LED. If the IN USE option is used the DISK CHANGE option must be disabled by removing the jumper on JJ2 between Pins 11 and 12.

WRITE PROTECT OPTION

This option allows the user to decide in which fashion the mini disk is protected against overwriting by setting of jumpers. The user can protect the mini disk if the notch is open, or if the notch is covered, as shown on the following table.

JUMPER	NOTCH OPEN	NOTCH COVERED	REMARKS
JJ4:3-4 JJ3:5-6	unprotected	protected	ECMA Standard
JJ3:3-4	protected	unprotected	optional

TABLE 2 - 3 WRITE PROTECT JUMPERING

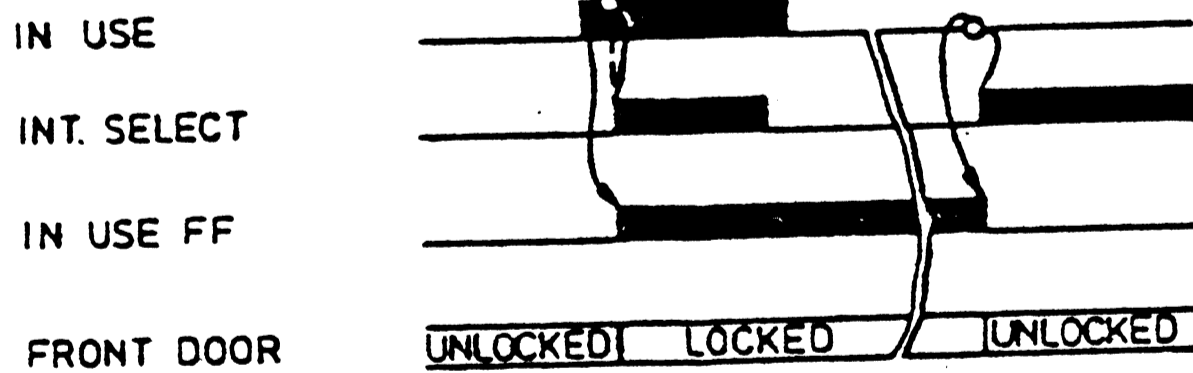

FIG. 2 - 13 TIMING DIAGRAM DOOR LOCK LATCH OPTION

STEPPER MOTOR SWITCHING

The stepper motor can be switched on and off by the MOTOR ON-signal, if there is a jumper installed between JJ4 Pins 1 and 2. If this jumper is installed, the mini disk drive must be repositioned by a recalibrate operation every time the drive and stepper motors are turned on.

DOOR LOCK OPTIONS

There are several possibilities to lock the front door:

1. Locking by the IN USE-signal
2. Locking by the Door Lock Latch Option
3. Locking while the drive is selected
4. Locking while the head is loaded

Also the circuit allows combinations of the possibilities written above:

5. If 1. or 3. is true
6. If 1. or 2. or 3. is true
7. If 1. or 4. is true
8. If 1. or 2. or 4. is true

LOCKING BY THE IN USE SIGNAL

The front door is locked as long as the IN USE-signal is activated. For this option the following jumpers must be installed:

JJ2	JJ3	JJ4
13-14	1 - 2 9 -10	9-10

LOCKING BY THE DOOR LATCH OPTION

The front door stays locked as long as the IN USE-FF is set. The following jumpers must be installed:

JJ2	JJ3	JJ4
13-14	1 - 2 9 -10	11-12

LOCKING WHILE THE DRIVE IS SELECTED

The front door is locked as long as the drive is selected. The jumpers must be set as follows:

Install:	JJ2	JJ3	Remove:	JJ3
	5 - 6	7 - 8 9 -10		1 - 2

LOCKING WHILE THE HEAD IS LOADED

The front door is locked as long as the read/write head is loaded. To allow this option, the following jumpers must be installed:

Install:	JJ3	Remove:	JJ3
	11-12 9-10		1 - 2

COMBINATIONS OF THE PREVIOUS DESCRIBED POSSIBILITIES

Combinations of the above described door lock options are also possible. In this case, the jumper JJ3:9-10 must be removed. The following combinations are feasible.

- DOOR LOCK = DOOR LOCK ENA + HEAD LOAD ENA
- DOOR LOCK = DOOR LOCK ENA + I / O ENA
- DOOR LOCK = DOOR LOCK ENA = IN USE + IN USE FF

To install this combinations all jumpers of the wanted combination must be installed except JJ3:9-10 (see also Installation and Operation).

ACTIVITY INDICATOR OPTIONS

The activity indicator is switched on when the drive is up to speed (SPEED-FF is set) and the read/write head is loaded (Jumper JJ4:7-8) or the door is locked (Jumper JJ4:5-6).

DISK CHANGE OPTION (FIG. 2-14)

Pin 34 of the interface can be used for the Disk Change Option when the IN USE option is not used. The DISK CHANGE-signal notifies the host system that the Flexy Disk has been changed even if the drive was deselected. As soon as the Flexy Disk is unloaded, the speed detector will deactivate the SPEED-signal and the DISK CHANGE-FF is set. The DISK CHANGE-signal is sent to the host system when the

drive is selected. The DISK CHANGE-FF will stay set when the new Flexy Disk is loaded. To deactivate the DISK CHANGE-signal, the host system must de-select the drive again. The DISK CHANGE-FF is then reset (see timing diagram Fig. 2-15). To enable the DISK CHANGE option, a jumper is installed at JJ2 Pins 11 and 12.

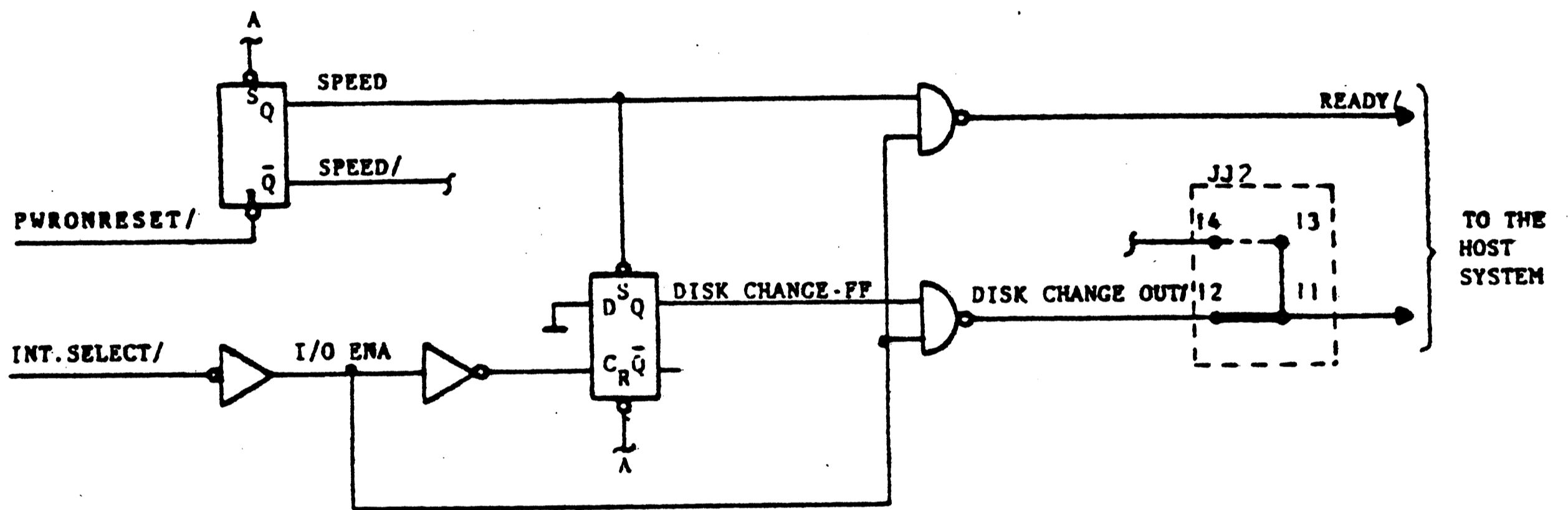

FIGURE 2- 14 DISK CHANGE LOGIC

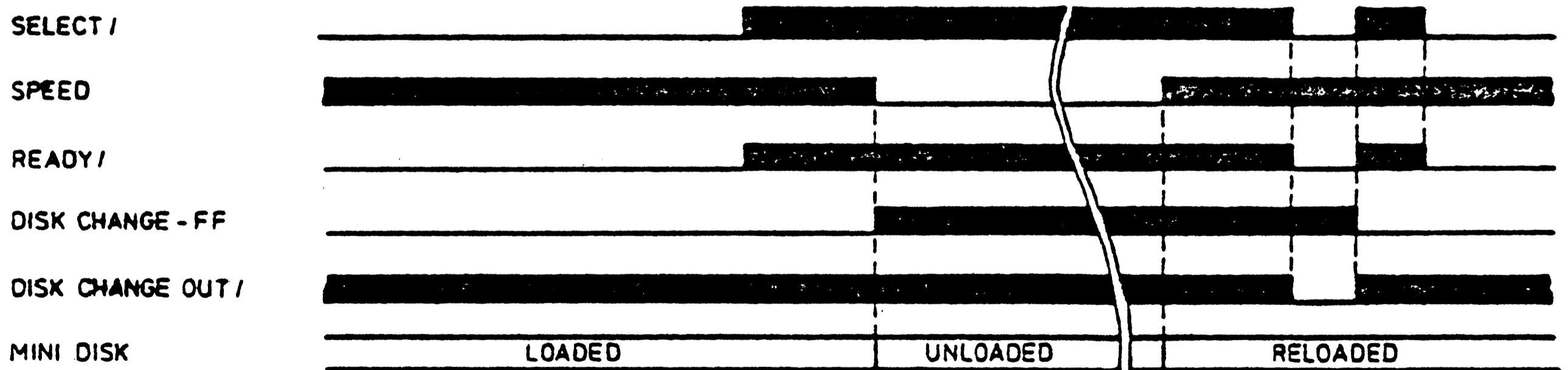

FIGURE 2 - 15 TIMING DIAGRAM DISK CHANGE LOGIC

2.2.2 STEPPER MOTOR CONTROL

The stepper motor is a four phase DC-motor and is controlled by the integrated circuit SAA 1027. This IC comprises the stepper motor drivers, a synchron counter and control circuits (see Fig. 2-16). Each STEP pulse from the host system rotates the stepper motor for one step. Each step corresponds to a rotation angle of 15°. The rotation of the stepper motor is converted to a linear motion of the R/W-head(s) by the spiral wheel. The direction of the motion of the R/W-head(s) depends on the input signal DIRECTION IN/. If this signal is active (low) the R/W-head(s) will be moved towards track 39 (in). The R/W-head(s) move out by each STEP pulse when DIRECTION IN/ is in a high state. Multiple track positioning is attained by the host system issuing a series

of STEP pulses at 12 msec intervals. Table 2-4 shows the output signals for "in" and "out" motion of the R/W-head(s). The DIRECTION IN-signal must be at the desired level 1 μsec before the trailing edge of the STEP pulse. Stepping is initiated by the trailing edge of the STEP pulse. The time between two consecutive STEP pulses must be 12 msec minimum (see Fig. 2-17). As long as WRITE GATE or WRITE INHIBIT is active during a write operation the STEP pulse interface line is inhibited by the input interface logic. In Fig. 2-16 a Zener diode is used in addition to the internal free wheeling diodes. This undamps the magnetic response at switch off time, causes armature to oscillate across target position. This reduces the influence of friction upon target positioning, decreases hysteresis error, resulting in precise settling on target position.

I N					O U T						
STEP	PHASE	A/	B/	C/	D/	STEP	PHASE	A/	B/	C/	D/
-		L	H	L	H	-		L	H	L	H
1		H	L	L	H	1		L	H	H	L
2		H	L	H	L	2		H	L	H	L
3		L	H	H	L	3		H	L	L	H
4		L	H	L	H	4		L	H	L	H

TABLE 2 - 4 SEQUENCE OF THE STEPPER MOTOR SIGNALS

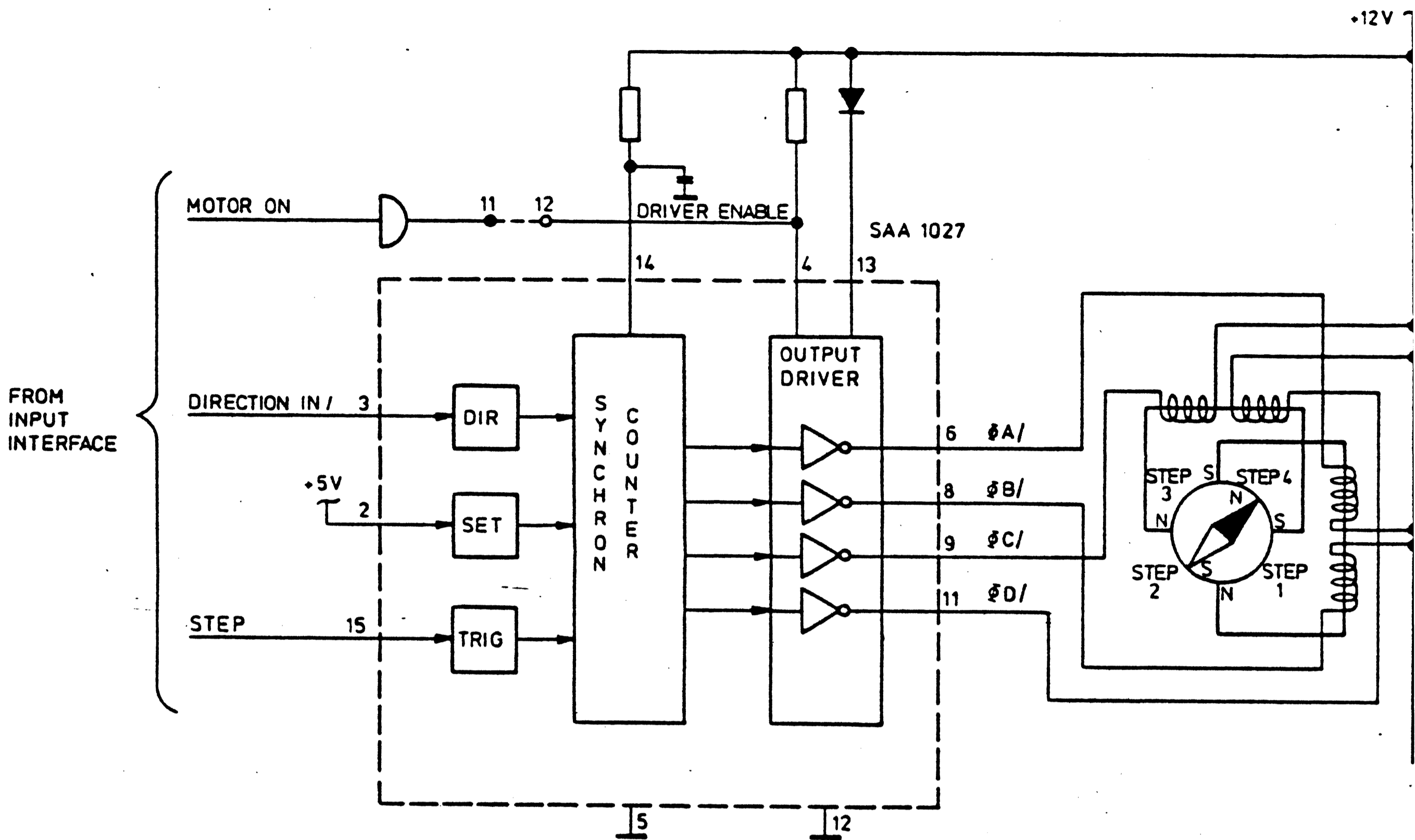
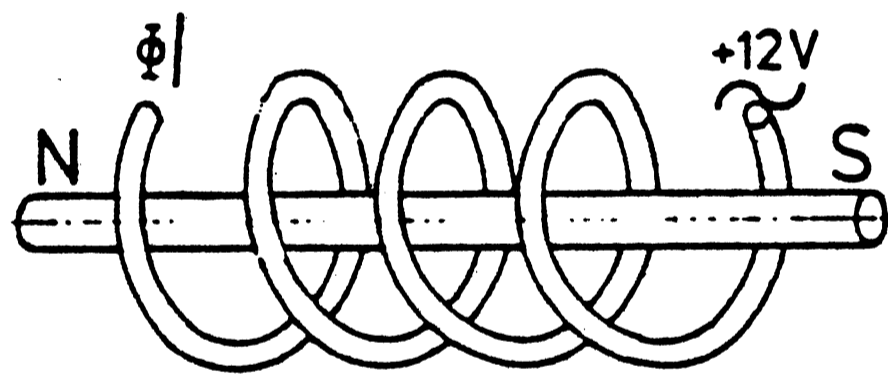

FIGURE 2 - 16 STEPPER MOTOR CONTROL



MAGNETIC POLARITY

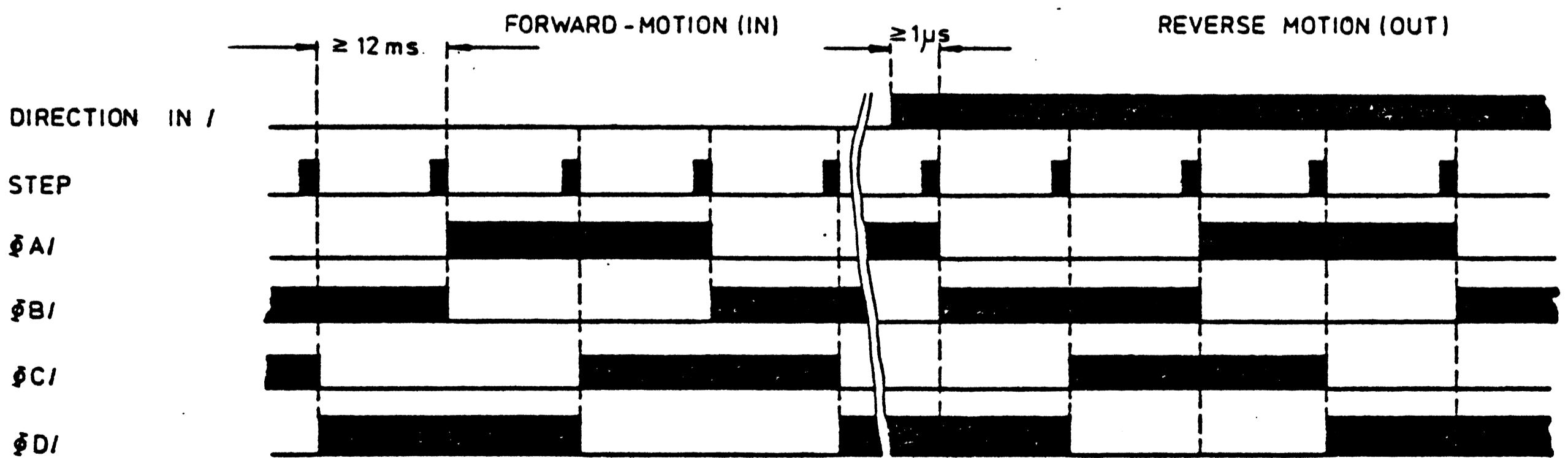

FIGURE 2 - 17 STEPPER MOTOR - TIMING DIAGRAM

2.2.3 DRIVE MOTOR CONTROL (FIG. 2-18)

The drive motor used in the BASF 6106 and 6108 is a DC-motor. Start and stop of the motor is controlled from the host system by the interface signal MOTOR ON. After the drive motor is started, a delay of 0.5 sec is needed to allow proper motor speed, before reading or writing. The speed of the drive motor is controlled by the integrated circuit ESM 227. It holds the EMF of the drive DC-motor to a constant value. Because the speed of the drive motor is proportional to its EMF, the speed

will be also constant. With the potentiometer R47 the drive motor must be adjusted to a disk speed of 300 RPM. The output voltage of the ESM 227 is controlled by the MOTOR ON-signal at Pin 12 of the chip. If MOTOR ON is inactive (low) T1 will be closed and holds T2 open. The drive motor stops. An active MOTOR ON-signal opens T1 and T2 is enabled. The drive motor is running and regulated, so that the Flexy Disk is rotating at 300 RPM.

T1o limits the drive motor start current to 0.7 A.

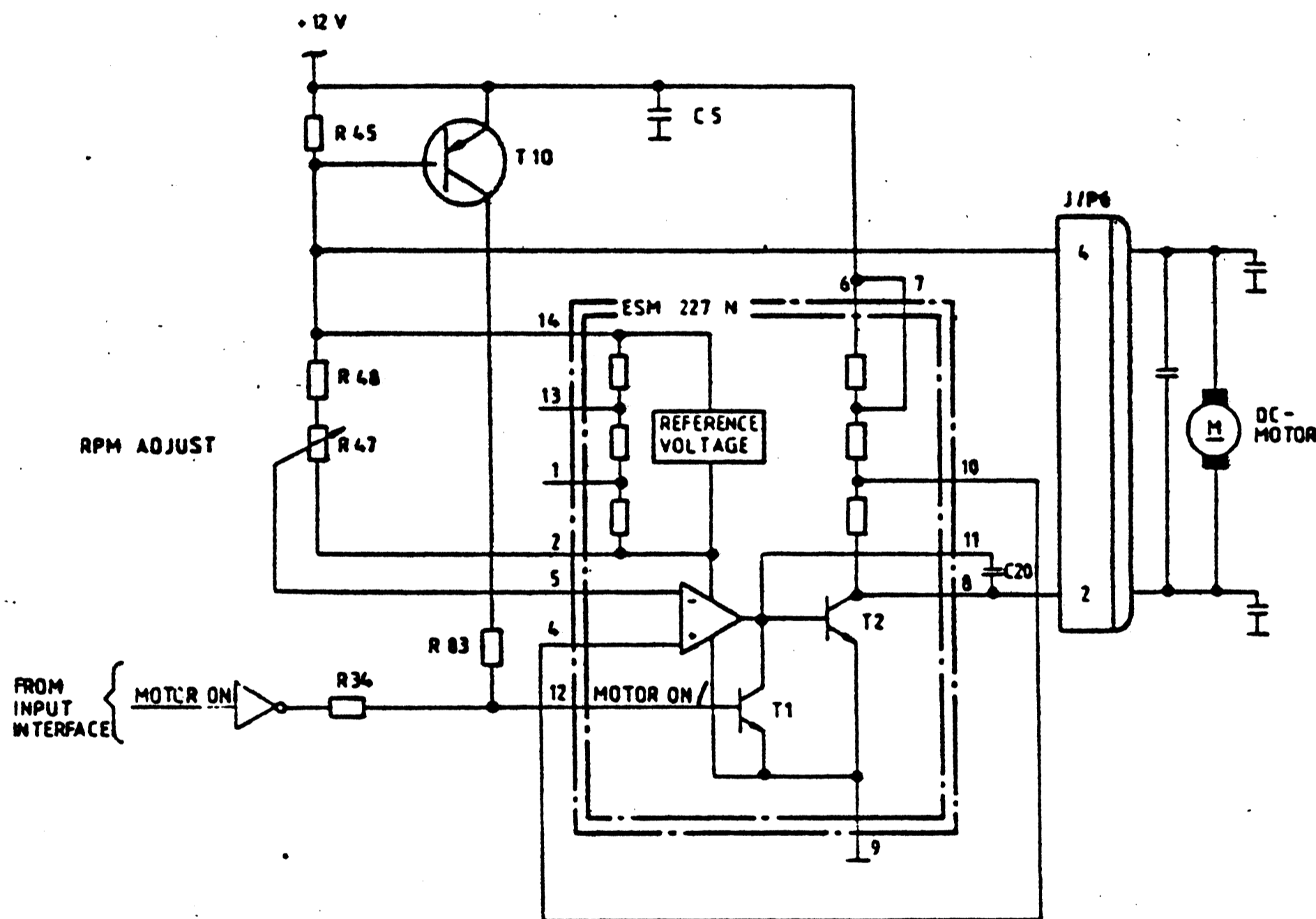

FIGURE 2 - 18 DRIVE MOTOR CONTROL

2.2.4 HEAD LOAD LOGIC (FIG. 2-19)

The head load mechanism is activated by the head load solenoid. This solenoid is energized when HEAD LOAD ENA is active and the mini disk is up to speed (SPEED is high). SPEED is activated by the speed detection logic. As the head load solenoid is activated, transistor T1 is closed for 20 ms by the 20 ms one shot and applies +12 V to the head load solenoid to supply sufficient starting current (see Fig. 2-20). When the 20 msec one shot times out, transistor T1 turns off, but transistor T13 will still remain on. +5 V is not applied to the head load solenoid by Resistor R99 and

the forward biased Diode D21 and the head load solenoid remains activated.

The head load solenoid will be deactivated when the HEAD LOAD ENA-signal goes high or the front door is opened (SPEED is low).

For the door lock solenoid and the activity LED two SN 75453 drivers are used. Both are enabled by SPEED of the ready detector circuit. The activity LED can be turned on if the head is loaded (HEAD LOAD ENA active) or if the door lock solenoid is activated (see Fig. 2-20). The door lock solenoid is activated if HEAD LOAD ENA or I/O ENA or DOOR LOCK ENA is active (see Fig. 2-20).

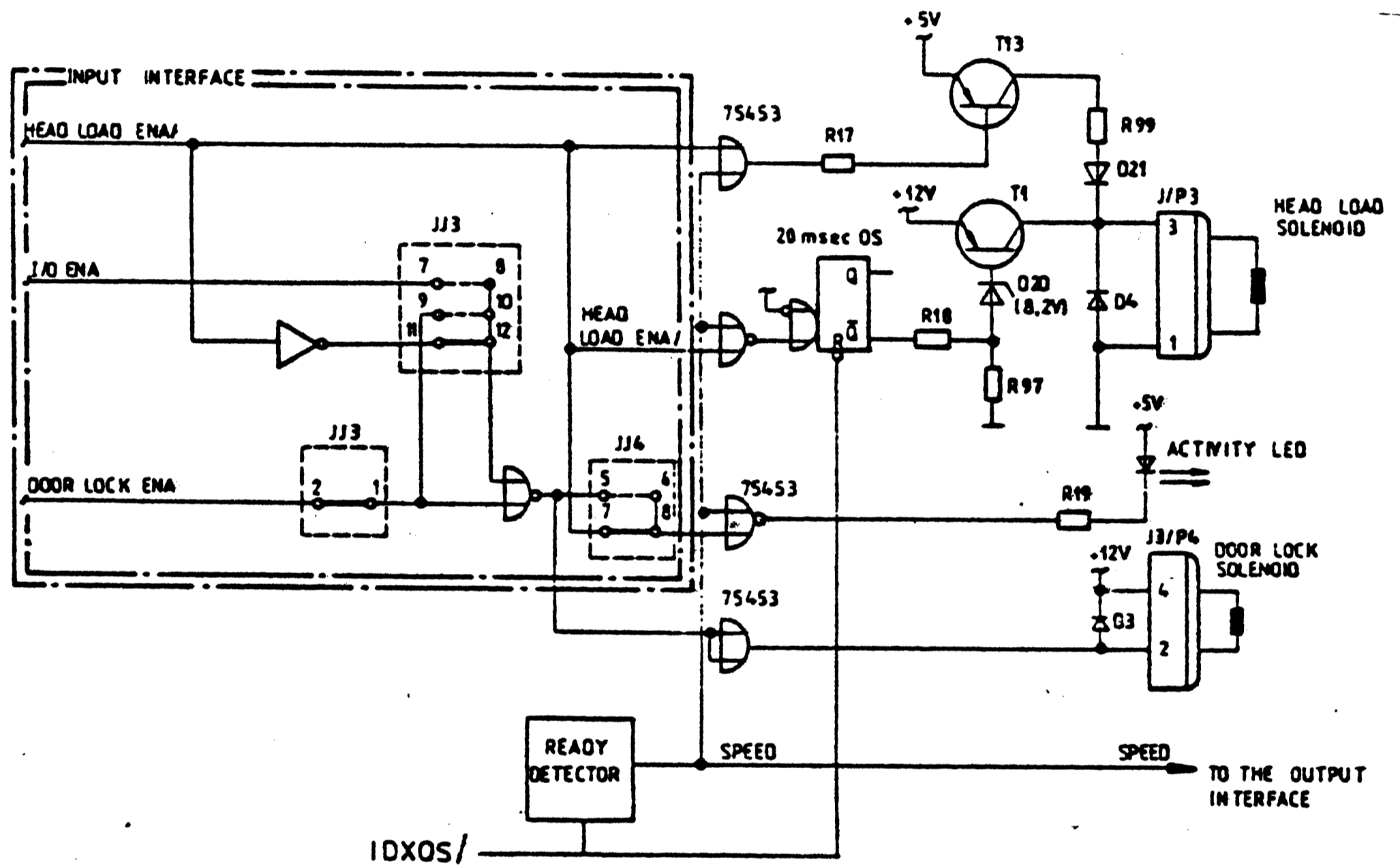

FIGURE 2 - 19 HEAD LOAD CIRCUIT DOOR LOCK SOLENOID AND ACTIVITY LED DRIVER

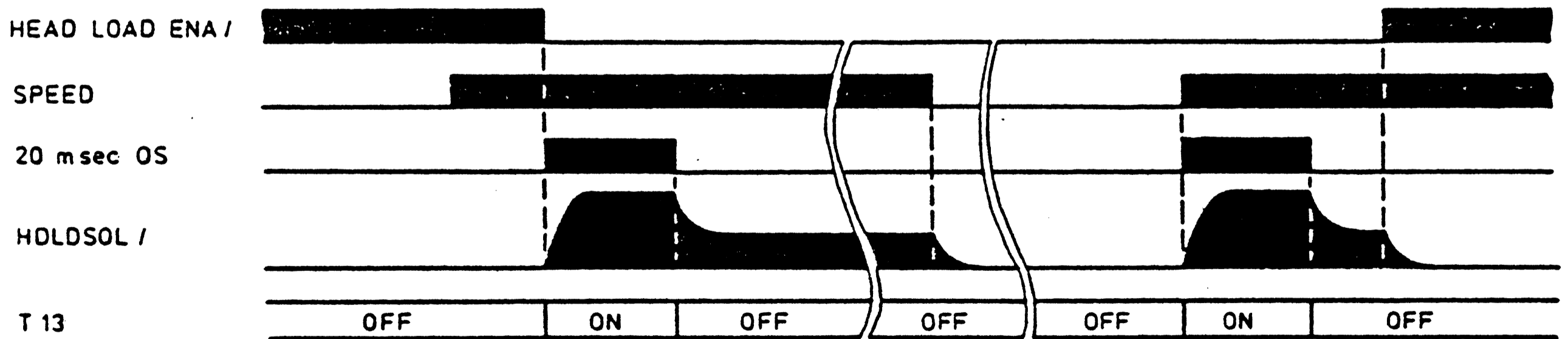

FIGURE 2 - 20 HEAD LOAD - TIMING DIAGRAM

2.2.5 TRACK ZERO DETECTOR

This logic generates the TRACK 00-signal when the read/write head is positioned at track zero. The host system uses this signal to recalibrate the positioning system. When the position of the read/write-head is unknown the host system sends step out pulses until TRACK 00 goes low.

The track zero detector is comprised of the track zero switch, a comparator circuit and a phase detector circuit, which detects the correct phase of the stepper motor. The track zero switch mounted on the deck assembly is activated by the head carriage. The logic circuit supports mechanical and optical track zero switches (see Fig. 2-21).

When the head carriage moves out, the track zero switch must be open before the read/write head reaches track four. When the head carriage moves

towards the track zero position the track zero switch must close after track four and before track zero. The TRACK ZERO-signal will be active when the track zero switch is closed and phase A and phase C of the stepper motor are activated. OUTENABLE (O ENA) must be high.

Fig. 2 - 22 shows the timing diagram when the host system attempts to step the head carriage beyond track zero. The mechanical stop on the spiral wheel prevents the read/write head from moving out further and holds it near track zero. But the TRACK 00-signal will be deactivated, because the stepper motor is in a wrong phase ($\emptyset B/$, $\emptyset C/$). If the host system sends three more step out pulses, the phasing of the stepper motor is correct again, the TRACK 00-signal is activated and the read/write head is positioned at track zero.

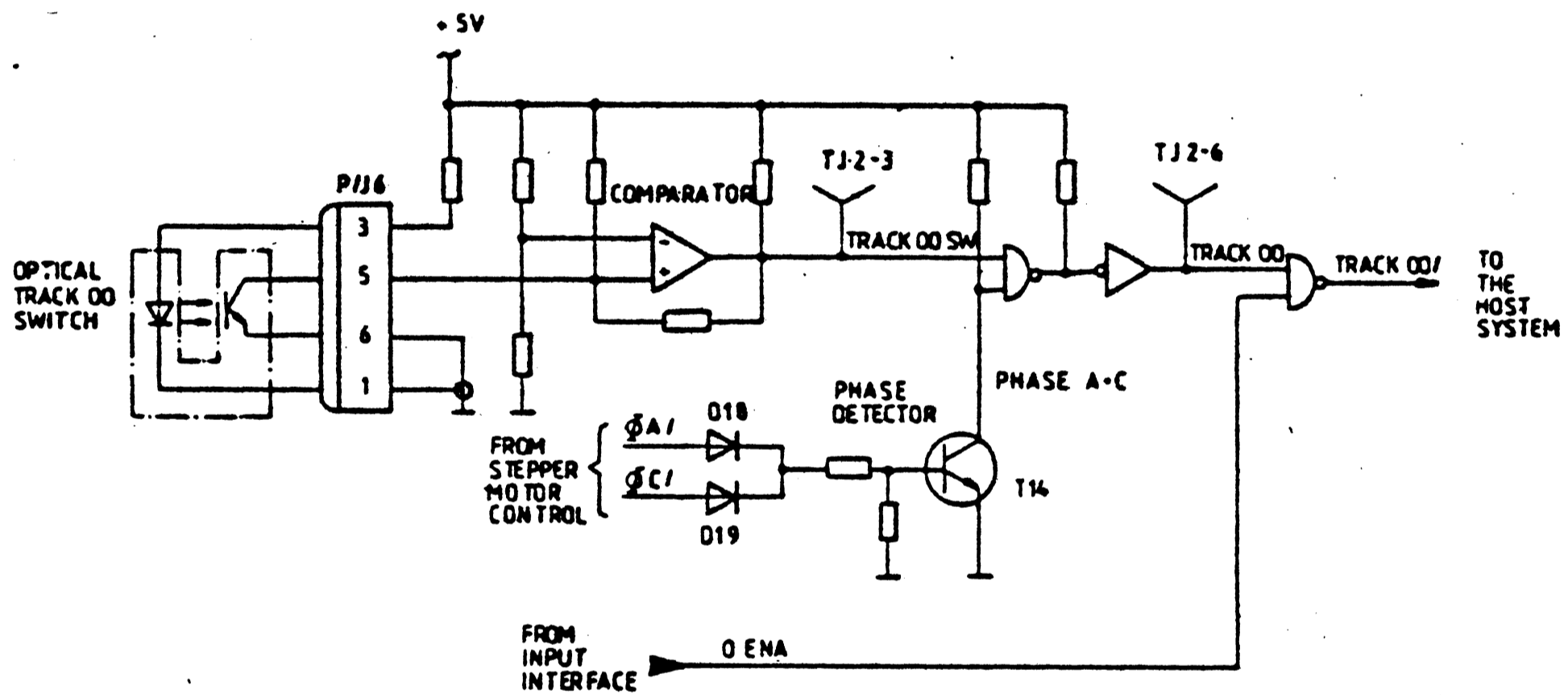

FIGURE 2 - 21 TRACK ZERO DETECTOR

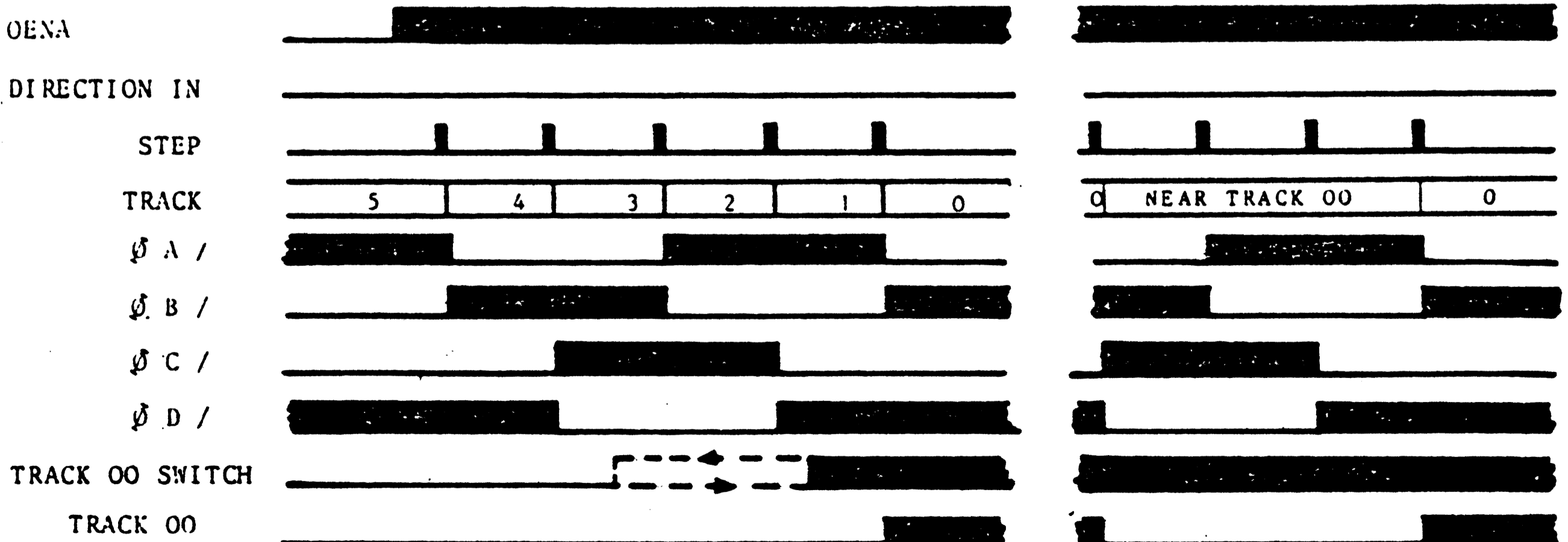

FIGURE 2 - 22 TRACK ZERO - TIMING DIAGRAM

2.2.6 WRITE PROTECT DETECTOR

The write protect detector (Fig. 2-23) is implemented like the index detector. A LED and a photo transistor are used with a comparator circuit to detect the write protect notch in the Flexy Disk. When a Flexy Disk with an open notch is inserted, the photo transistor will sense the light of the LED causing the negative input of the comparator to go low and the output of the comparator "NOTCH OPEN" will be high. The setting of the write protect jumpers decides, whether writing is allowed or not (see the following table).

If WRITE INHIBIT is high, the WRITE ENABLE-signal is disabled. The mini disk drive is now unable to write, even if the host system will activate the WRTGATE/ interface line. The WRITE PROTECT/ - signal is sent to the host system when OUTENABLE is high. The WRITE PROTECT-line informs the host system, that a write protected Flexy Disk is inserted. If an unprotected Flexy Disk is inserted, WRITE PROTECT/ will be inactive and write operations are allowed.

JUMPER	NOTCH COVERED	NOTCH OPEN	REMARKS
JJ3:3-4	unprotected	protected	optional
JJ3:5-6 JJ4:3-4	protected	unprotected	ECMA

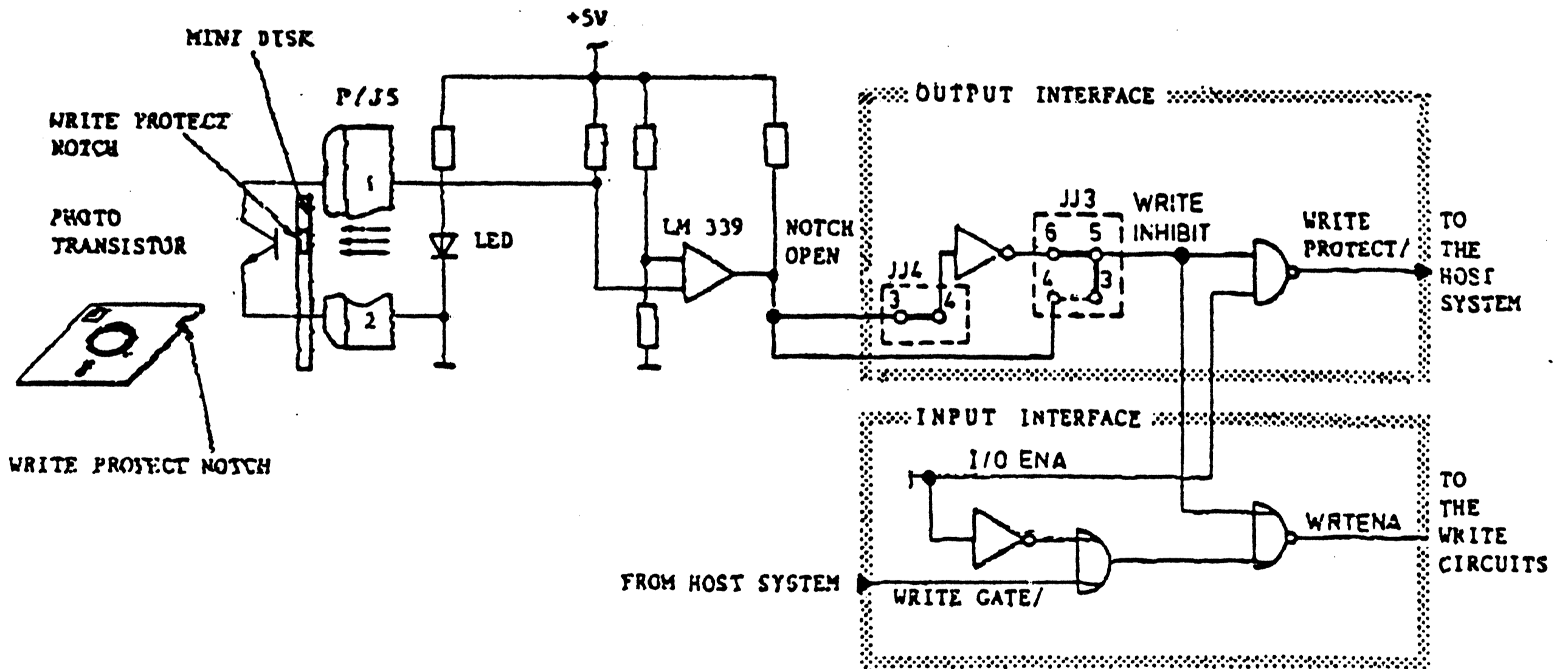

FIGURE 2 - 23 WRITE PROTECT DETECTOR

2.2.7 INDEX/SECTOR- AND READY DETECTOR

2.2.7.1 INDEX/SECTOR DETECTION

The index/sector detector comprises a phototransistor mounted on the deck assembly, a light emitting diode (LED) on the PCB and a comparator (see Fig. 2-24). As the index hole or sector (optional) hole passes between LED and phototransistor, light from the LED is passed to the phototransistor. This

results in a negative pulse of about 1.5 msec at the inverting input of the comparator. The output pulse of the comparator is sent to the host system by the output interface when I/O ENA is active. Also the INDEX-pulse is used as input signal for the ready detector logic.

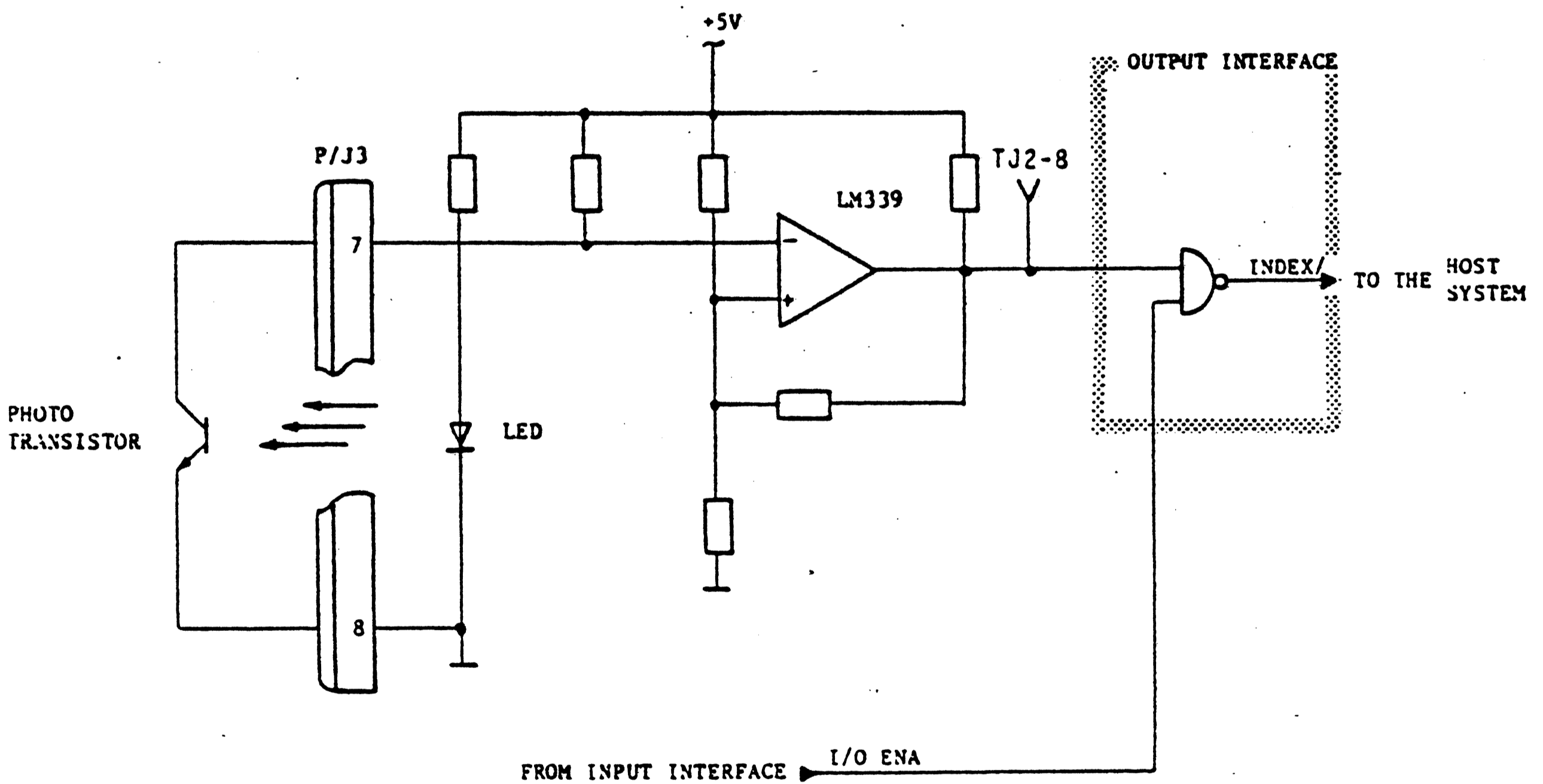

FIGURE 2 - 24 INDEX DETECTOR

2.2.7.2 READY DETECTION

The ready detector (Fig. 2-25) is used to monitor the INDEX pulses for the rotational speed of the disk. The INDEX pulses are input to the 300 msec hold-over-one shot. When the time between two consecutive INDEX pulses is greater than 300 msec, the index counter is held reset. If the time is less than

300 msec, the hold-over-one shot is held fired and enables the index counter. When three consecutive INDEX pulses have clocked the index counter, SPEED is high and the READY/ signal is sent to the host system (see Timing Diagram Fig. 2-26).

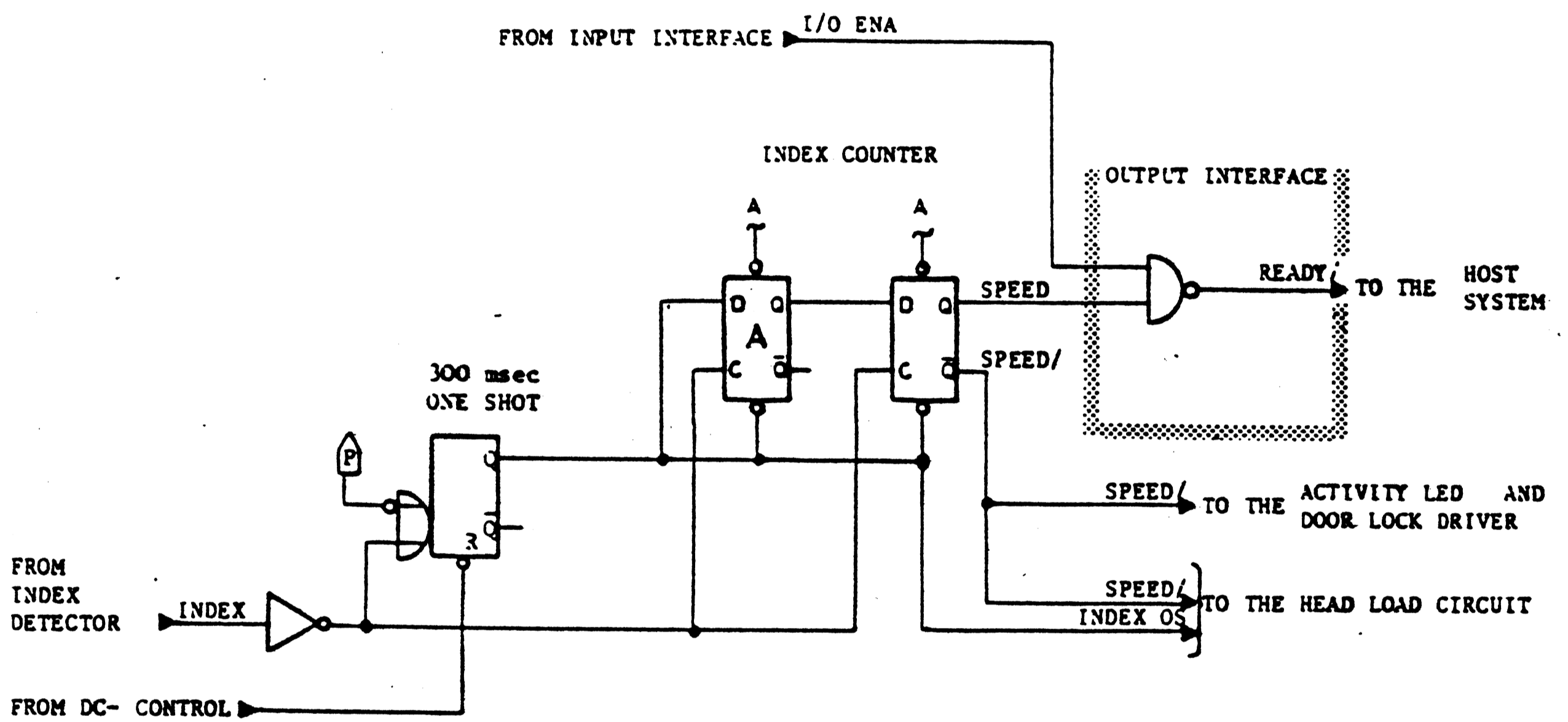

FIGURE 2 - 25 READY DETECTOR

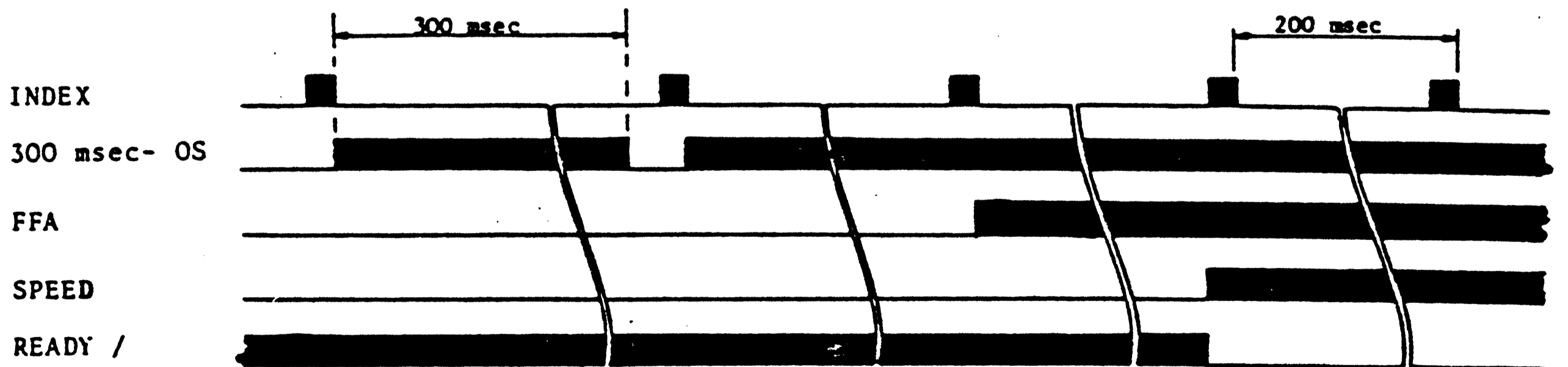

FIGURE 2 - 26 READY TIMING

2.2.8 TYPE OF HEADS

2.2.8.1 READ/WRITE HEAD

The read/write heads used in the BASF 6106/6108 disk drives are tunnel erase type heads. Data is recorded at a flux density of 3536 to 5536 flux changes per inch (fci).

The nominal frequencies on the read/write head are 62.5 kHz and 125 kHz when FM recording technique and 62.5 kHz, 125 kHz and 83.3 kHz when MFM recording technique is used. In FM mode the nominal distance between flux reversals is 4 μ s or 8 μ s. In MFM 6 μ s flux reversal spacings are also encountered.

The radial density is 48 tracks per inch (tpi). This gives 0.0208 inch nominal track to track spacing. The tunnel erase gaps trim the track width from 0.014 inch after write to 0.013 inch after erase (see Fig. 2-27).

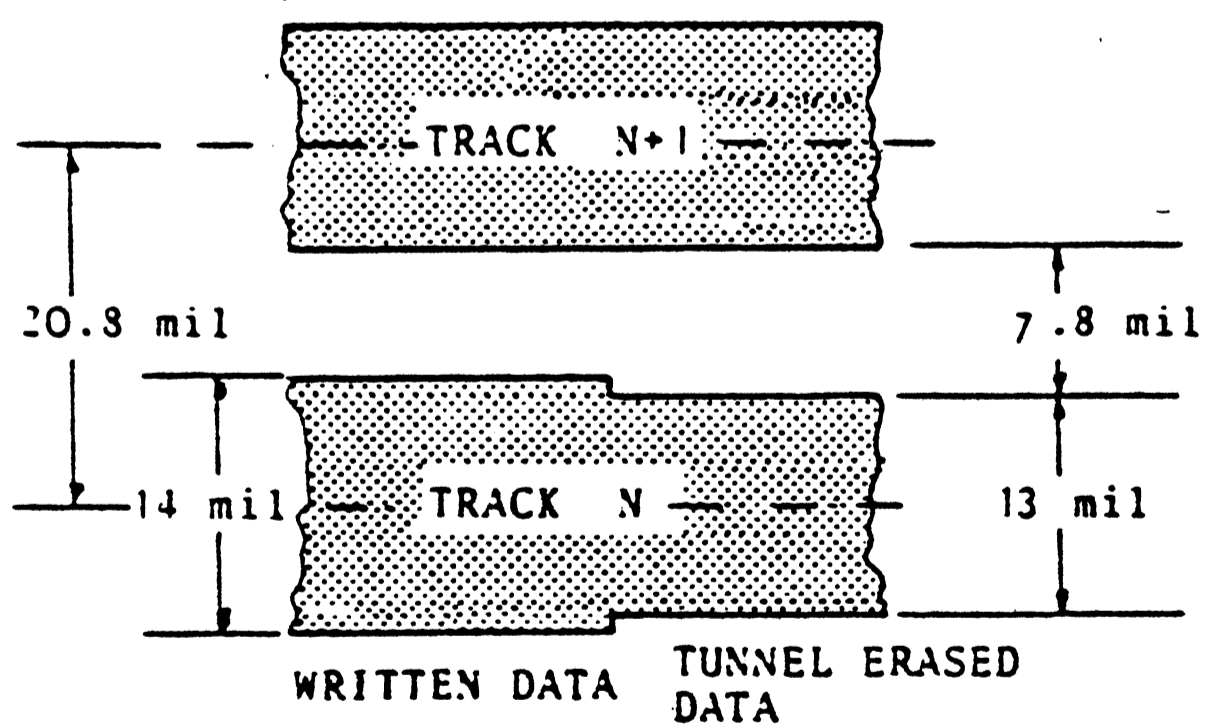

FIG. 2 - 27 TRACK GEOMETRY

The read/write head contains three coils: two read/write coils and the erase coil (see Fig. 2-28). The erase coil is energized during every write operation and limits the track width and provides low noise guard bands on each side of the recorded track. The two read/write coils are wound on a single core and are center tapped. The electrical connections of the read/write head are shown in Fig. 2-28. During a write operation the write current will be directed alternately to one of the two read/write coils by a flipflop. This causes a flux change every bit to be written. The old data on the track will be overwritten by the new data stream.

On a read operation an output voltage is induced in the read/write head by every flux change that passes the gap of the read/write head. This voltage is used by the read circuits to recover the written data.

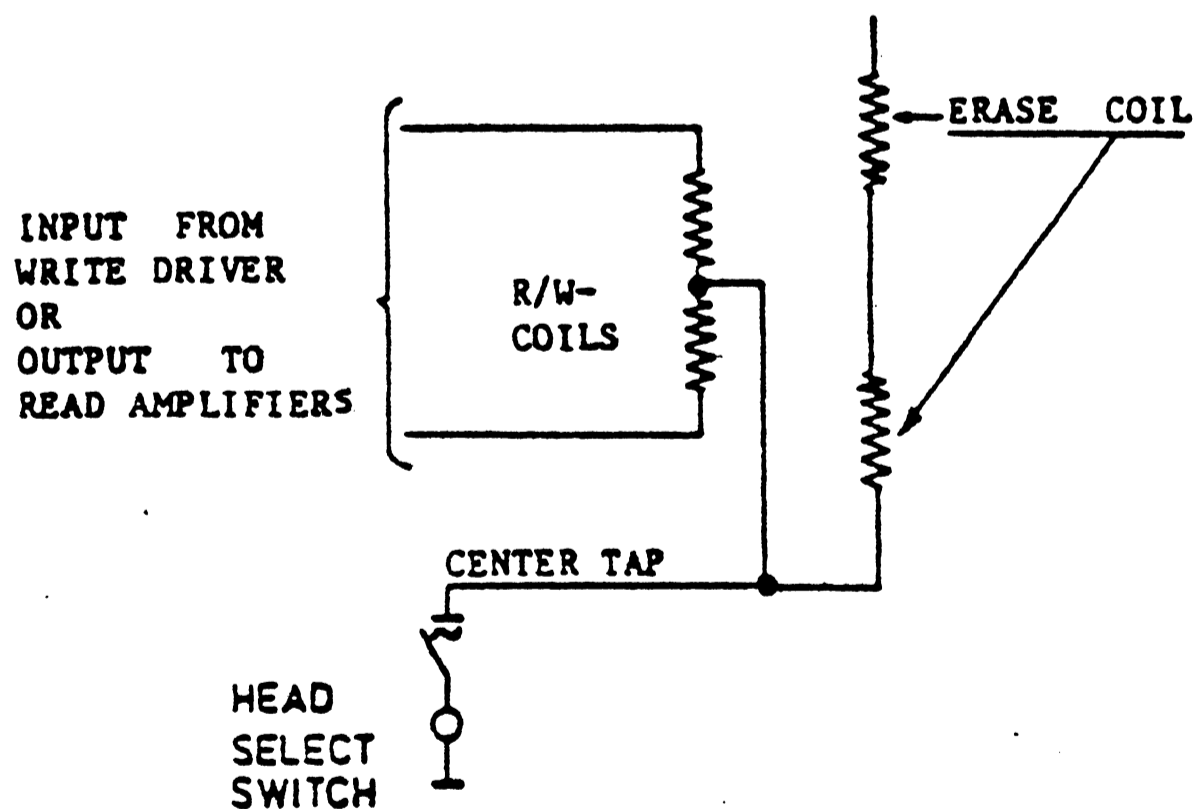

FIG. 2 - 28 ELECTRICAL CONNECTION OF THE READ/WRITE HEAD

2.2.8.2 SIDE SELECT LOGIC

The side select logic is used by the double sided mini disk drive (BASF 6108) and selects either head 0 or head 1, depending whether the SIDE 1-signal from the input interface is high or low. The side select logic in Fig. 2-29 consists of two head select switches (T 11, T 12 and associated circuits) and a diode matrix (D 1, 2, 11, 12, 16, 17). If the SIDE 1-signal is low, transistor T 11 is on and head 0 is selected. The signal COM0/ is at ground and generates a forward bias to the diodes D 11, D 12 and D 16. If the SIDE 1-signal is high, transistor T 12 is on and head 1 is selected. The signal COM1/ is at ground and generates a forward bias to the diodes D 1, D 2 and D 17.

In a read operation the read signal induced in the read/write coils of head 0 is transferred through the diodes D 11, D 12 to the read circuits. In a write operation the write current generated in the write circuits flows through these diodes into the read/write coils. The erase current is fed to the erase coil by the diode D 16. At the same time the diodes D 1, D 2 and D 17 are blocked, because transistor T 12 is off. Transistor T 12 will be on when SIDE 1 is high and head 1 is activated.

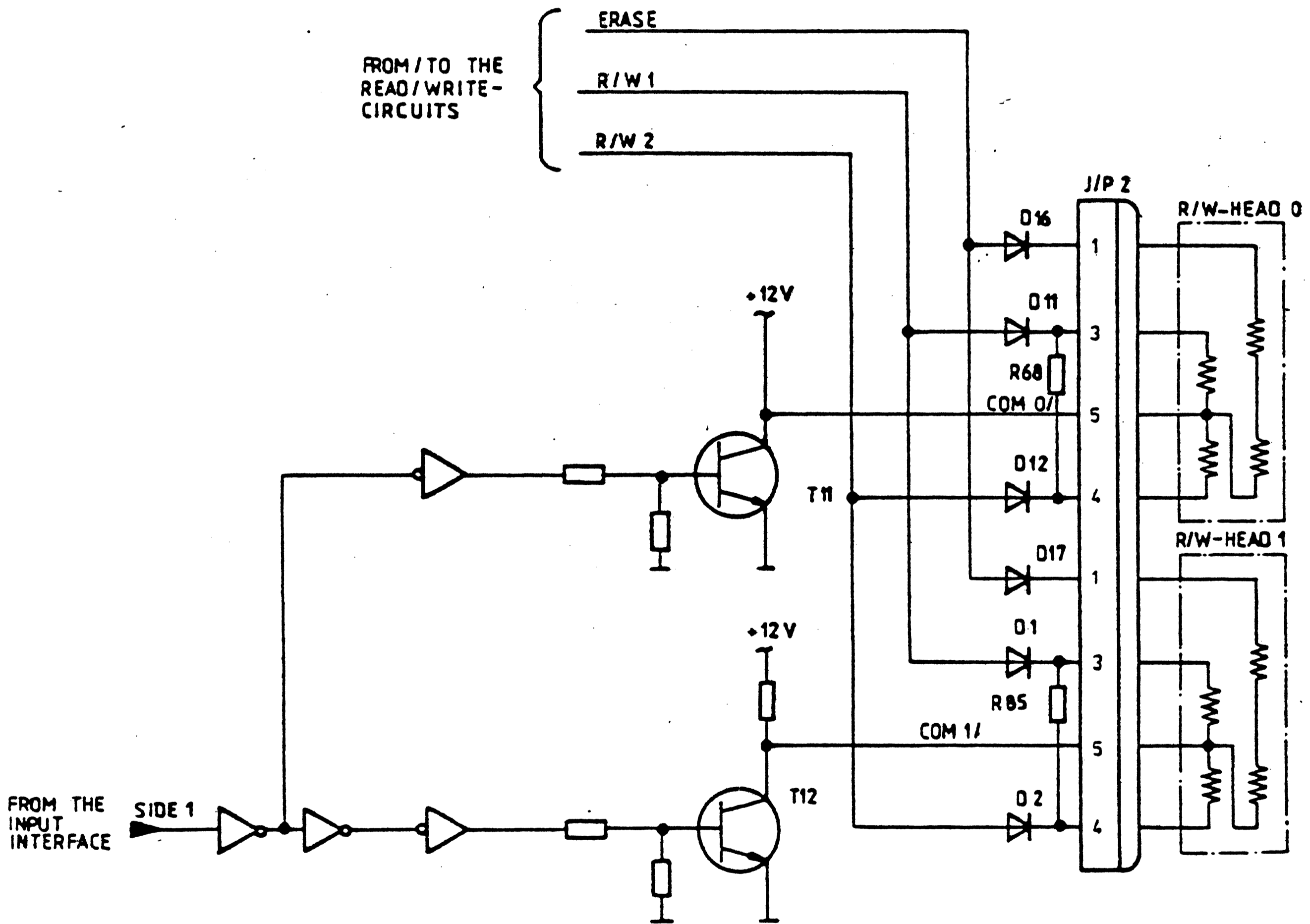

FIGURE 2 - 29 SIDE SELECT LOGIC

2.2.9.1 WRITE INITIATE

The write circuits encode serial data from the host system to magnetic flux patterns recorded on the Flexy Disk. A write operation is initiated by the host system activating the following input lines (see Fig. 2-30).

- SELECT/ selects the drive and loads the head if no head load option is installed.
- MOTOR ON/ rotates the mini disk.
- WRITE GATE/ turns on the write circuits.
- WRITE DATA/ encoded write data.
- HEAD LOAD/ loads the head if head load option is used.

A simplified logic of the write circuit is shown on Fig. 2-31 a. The write circuits are activated by WRTENA/which is active when the host system sends WRITE GATE. The drive must be selected and the disk not write protected. The data stream from the host system is divided by the write flipflop. It alternately turns on transistors T3 and T4 (see Fig. 2-31 b). The write currents I_w and I_w' which are determined by the resistor R 35 flow then alternately through the windings W_1 and W_2 . The write current and erase current can be blocked by the DC-control logic, if a power failure has been detected. The erase current I_E is turned on by transistor T5 when ERASENA/ is low.

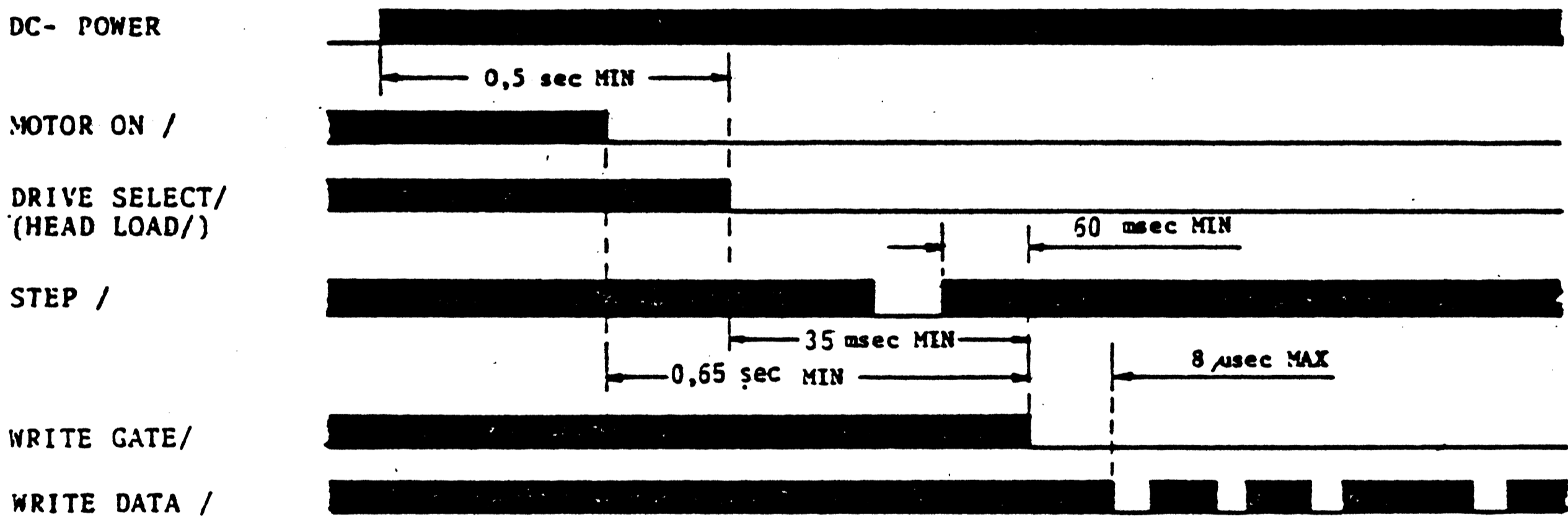

FIGURE 2 - 30 WRITE INITIATE TIMING

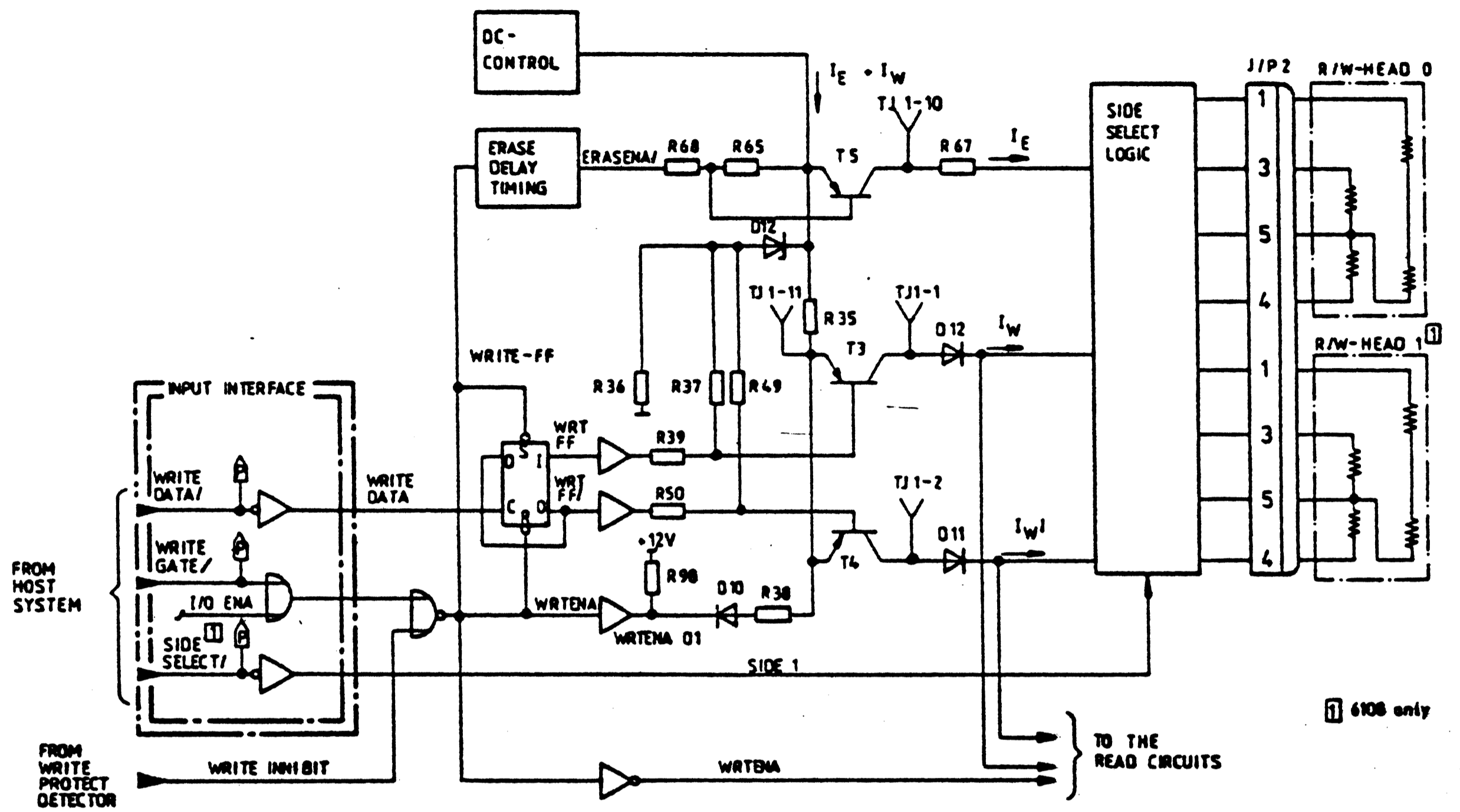

FIGURE 2 - 31 a. SIMPLIFIED WRITE CIRCUITS BASF 6106/6108

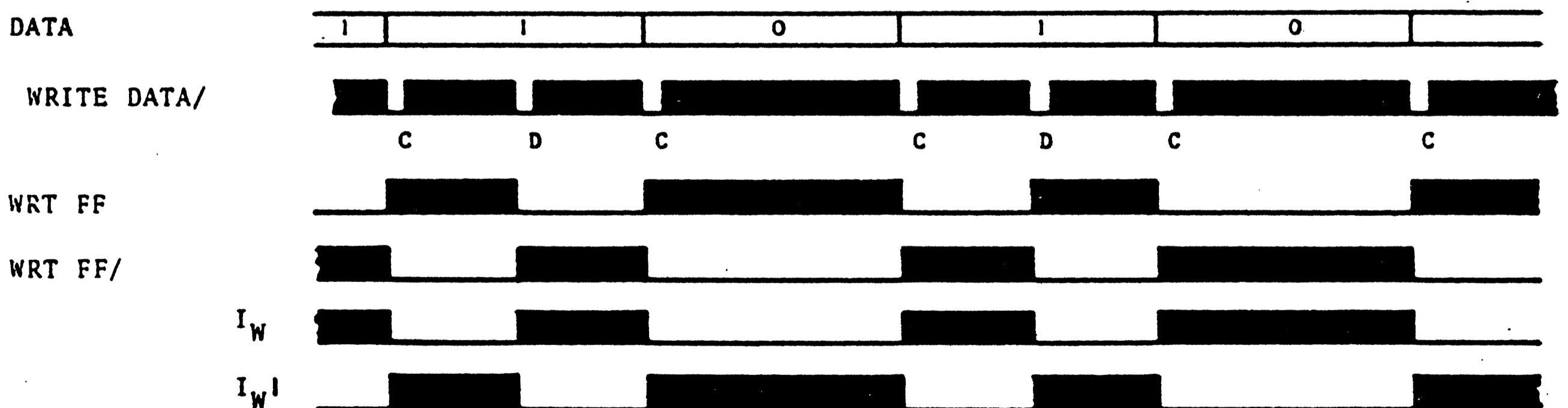

FIGURE 2 - 31 b TIMING DIAGRAM - WRITE OPERATION FM (SIMPLIFIED)

2.2.9.3 ERASE DELAY LOGIC

ERASENA/ is always switched a certain delay time after WRITE GATE/. The value of the erase current is determined by the value of the resistor R67. The delay of the erase current is necessary, because the tunnel erase gaps are physically located behind the read/write gap. This causes the erase gap to reach the same place on the track later than the read/write gap. Fig. 2-32 shows the erase delay logic. Fig. 2-33 is a timing diagram for the erase delay logic.

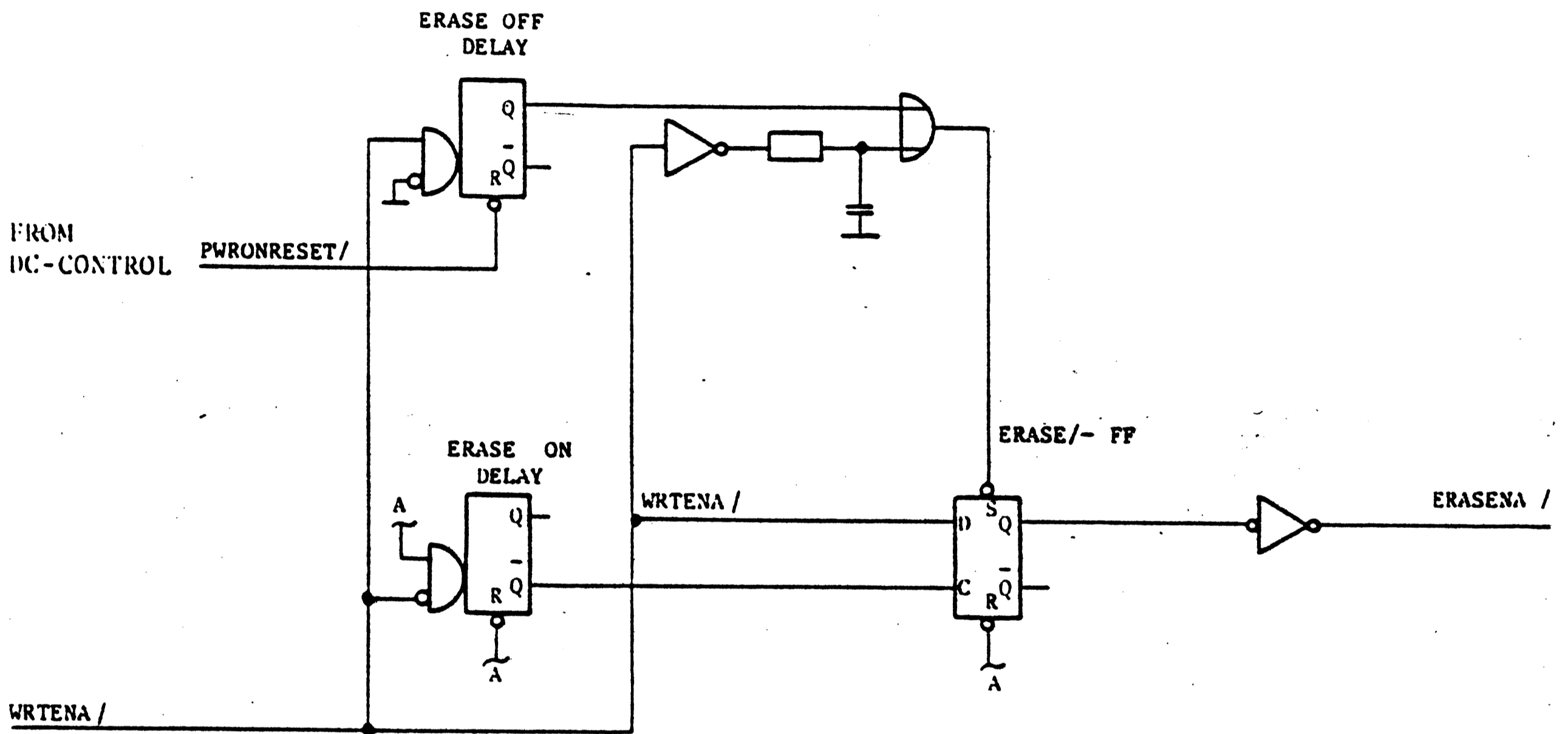

FIGURE 2 - 32 ERASE DELAY LOGIC

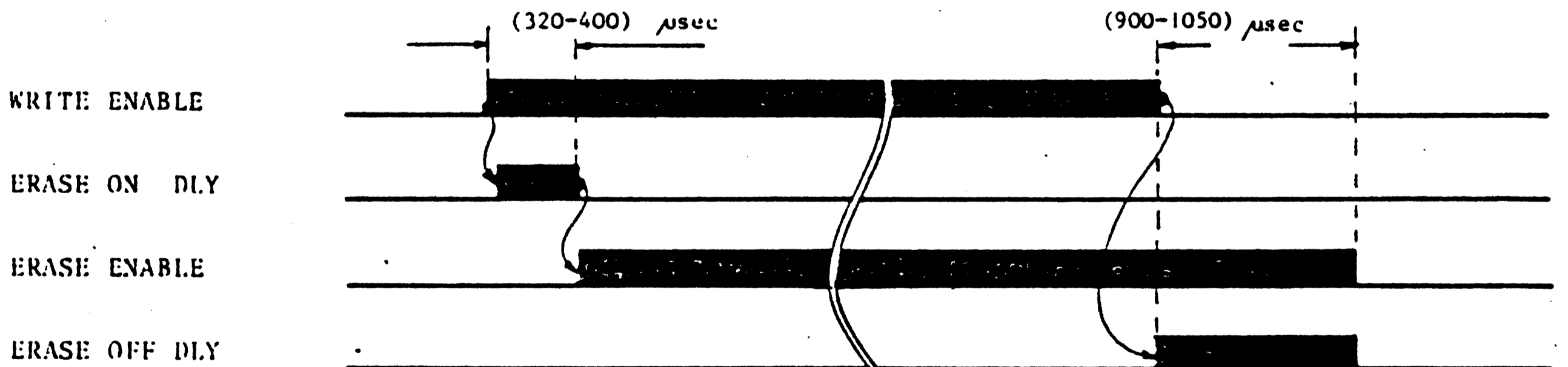

FIGURE 2 - 33 ERASE DELAY TIMING

2.2.10 READ CIRCUITS

● HEAD LOAD/

loads the head if head load option is used.

2.2.10.1 READ INITIATE AND READ BLOCK DIAGRAM

The read circuits recover data recorded on the Flexy Disk by a write operation. A read operation is initiated from the host system by activating the following lines:

- SELECT/ selects the drive and loads the head if Auto Head Load option is used.
- MOTOR ON/ rotates the Flexy Disk.

● SIDE SELECT/

selects head 0 or 1

The signal WRITE GATE/ must be inactive to enable the read circuits. Fig. 2-35 shows the read initiate timing. The read circuits shown on Fig. 2-34 comprise an integrated read amplifier system and the necessary external components.

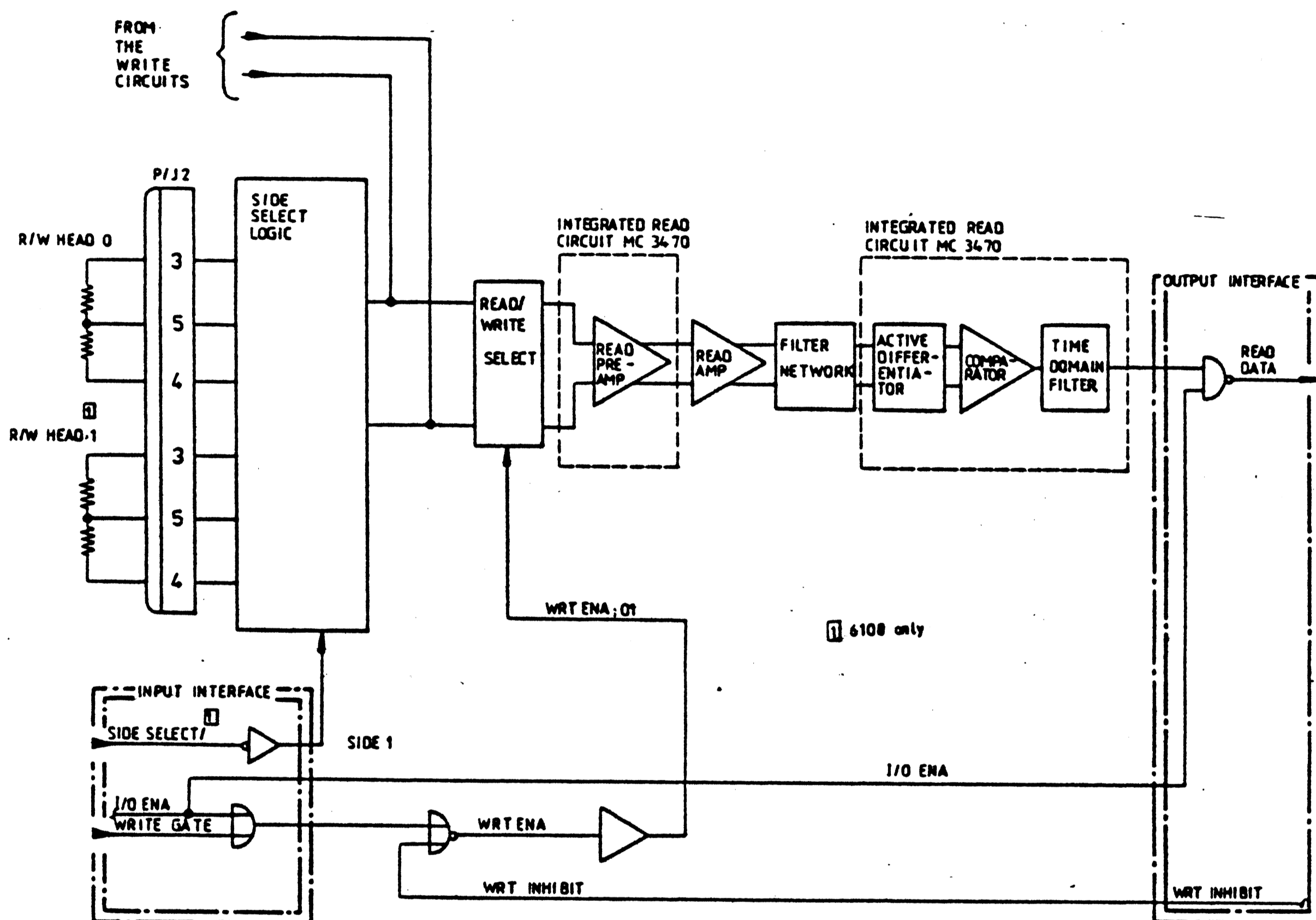

FIGURE 2 - 34 READ CIRCUITS BASF 6106/6108 (SIMPLIFIED)

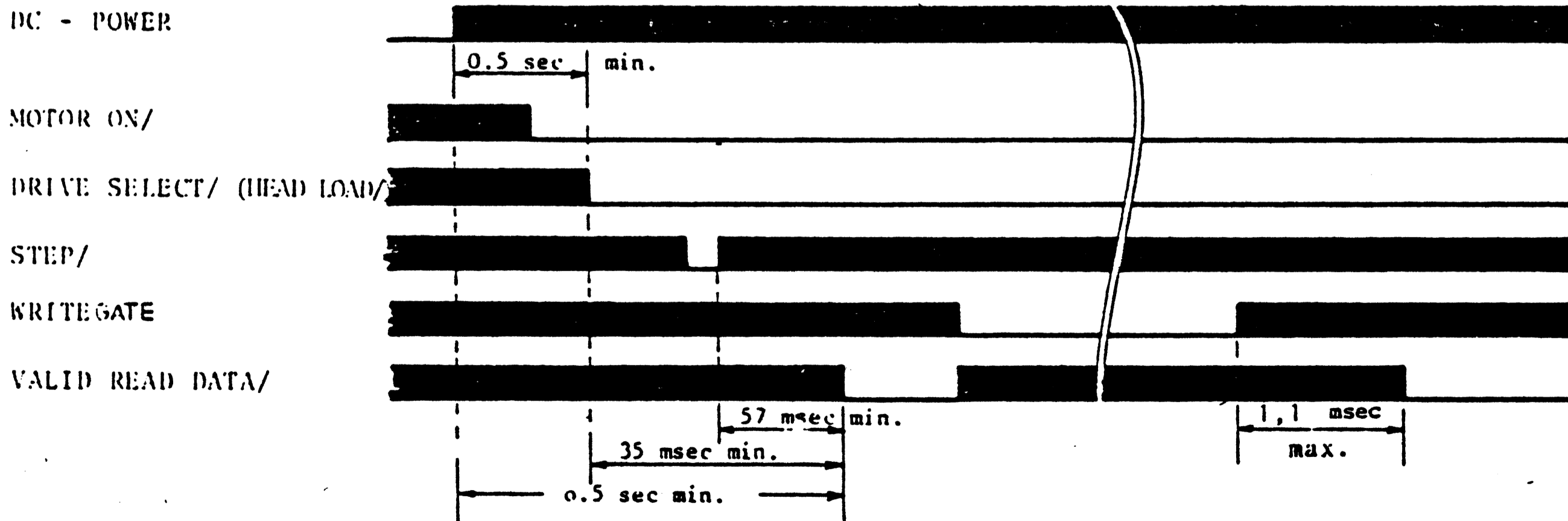

FIGURE 2 - 35 READ INITIATE TIMING

2.2.10.2 READ/WRITE SELECT

The read/write select circuit consists of two MOS-FET switches. The inputs of the switches are connected to the read/write coils of the selected read/write head. The outputs of the switches are connected to the read preamplifier (see Fig. 2-36).

When the disk drive is operating in the WRITE-mode, WRTENA ; 01 is high and T6 and T7 are open. The read/write coils are disconnected from the read preamplifier. In the READ-mode (WRTENA ; 01 is low) the output signal of the selected read write head is switched to the read preamplifier.

2.2.10.3 READ AMPLIFIERS AND FILTER NETWORK
(FIG. 2 - 37)

For amplification of the read signal a high gain linear amplifier of the read LSI and an external transistor stage are used. Both circuits increase the read signal amplitude by a gain of ~ 260. This amplified signal feeds into a filter network. The filter network is a low pass filter with a bandwidth of ~ 270 kHz.

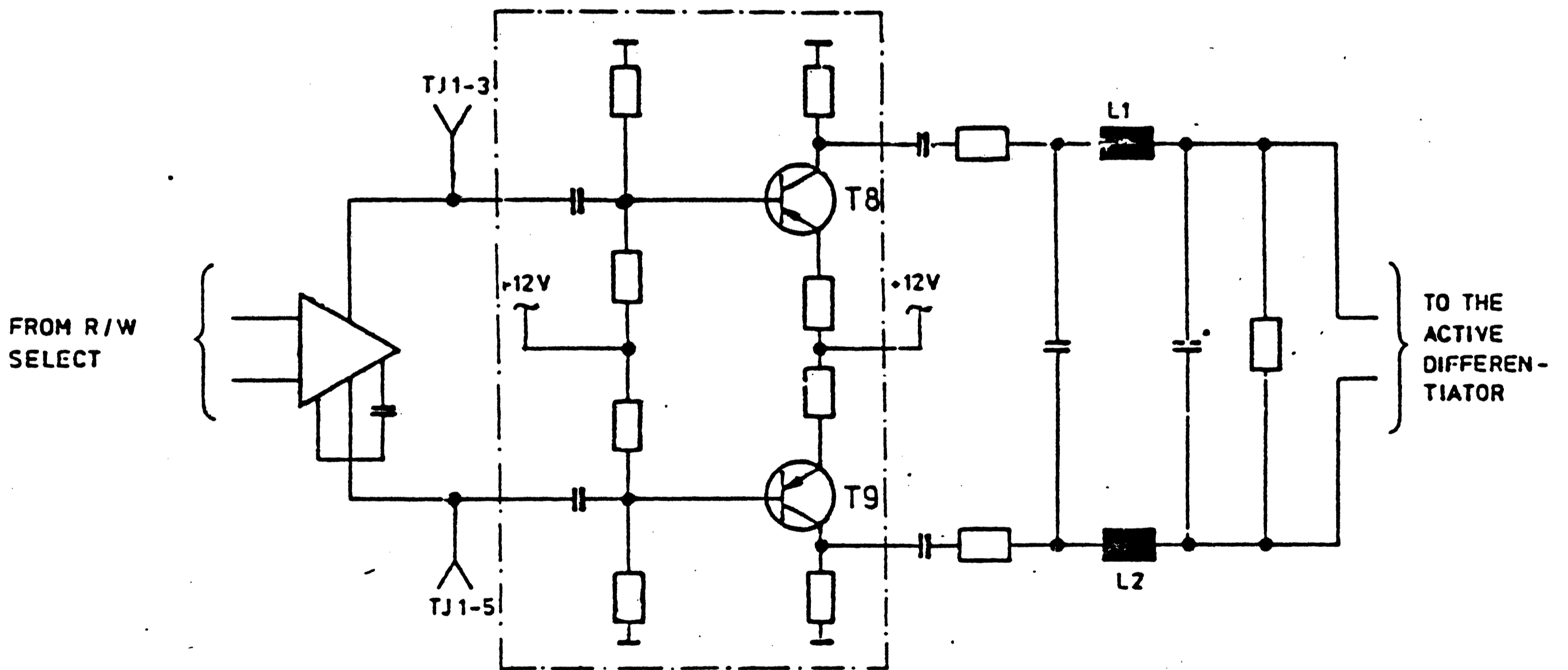
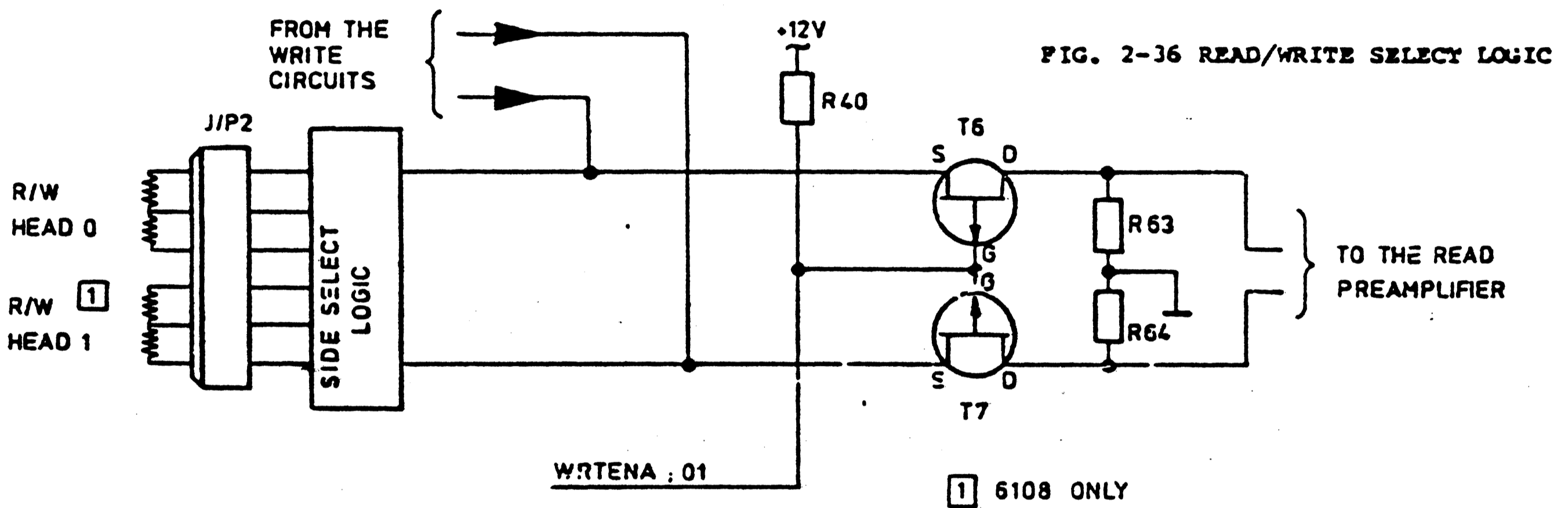

FIG. 2 - 37 READ AMPLIFIERS AND FILTER NETWORK

NOTE: Refers to PCB-Assy 88366-001, readamp. deleted in Assy - 002

Both circuits are part of the read LSI MC 3470. A simplified circuit is shown on Fig. 2-38. The active differentiator is implemented by a differential amplifier with capacitor coupled emitters. The current through this capacitor and also through the collector resistor will be a derivative of the input voltage.

$$I_c = C \cdot \frac{dV_{in}(t)}{dt}$$

Also the output voltage V_o of the differential amplifier will be a derivative of the input voltage.

$$V_o = 2 R \cdot I_c = 2 R C \frac{dV_{in}(t)}{dt}$$

The output voltage V_o is applied to the comparator which provides zero crossing detection of the waveform. Since the capacitor shifts the current $\sim 90^\circ$ to the input voltage peak detection of the input voltage is performed. Fig. 2-40 shows a timing diagram of the differentiator and comparator circuit.

The purpose of the time domain filter is to suppress false crossovers of the comparator caused by shouldering in the differentiated read signal. This can happen on outer tracks of high resolution disks when high resolution heads are used. The time domain filter contains a pulse generator, the time domain one shot and the time domain flipflop (see Fig. 2-39) and is part of the integrated read LSI. The pulse generator generates a short pulse for every transition on its input. These pulses are used to trigger the time domain one shot. The pulse duration of the time domain one shot is determined by an external RC-combination and is set to less than 2 μ sec for the BASF 6106 and 6108. The state of the comparator output is loaded into the time domain-flipflop by the trailing edge of the time domain one shot 2 μ sec later (see Fig. 2-40). Because false zero crossings always exist for a shorter time, the time domain flipflop will not change when it is clocked by false crossovers.

The crossover detector consists of a bidirectional one shot which is triggered by each transition of the time domain flipflop. The pulse width of the crossover detector can be adjusted by external elements. For the BASF 6106 and 6108 the output pulses (READ DATA/) of the crossover detector are set to 500 nsec.

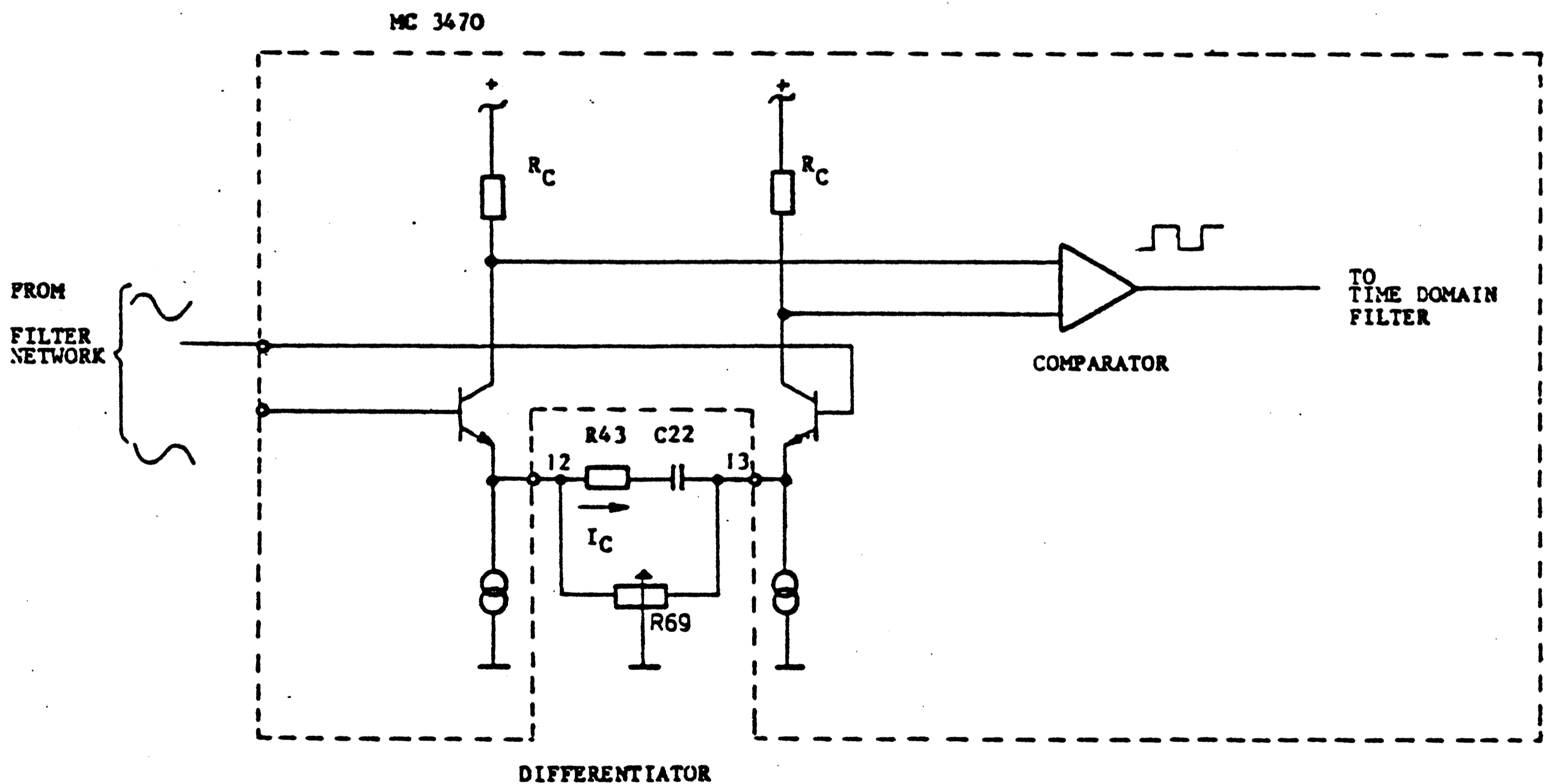

FIGURE 2 - 38

ACTIVE DIFFERENTIATOR AND COMPARATOR

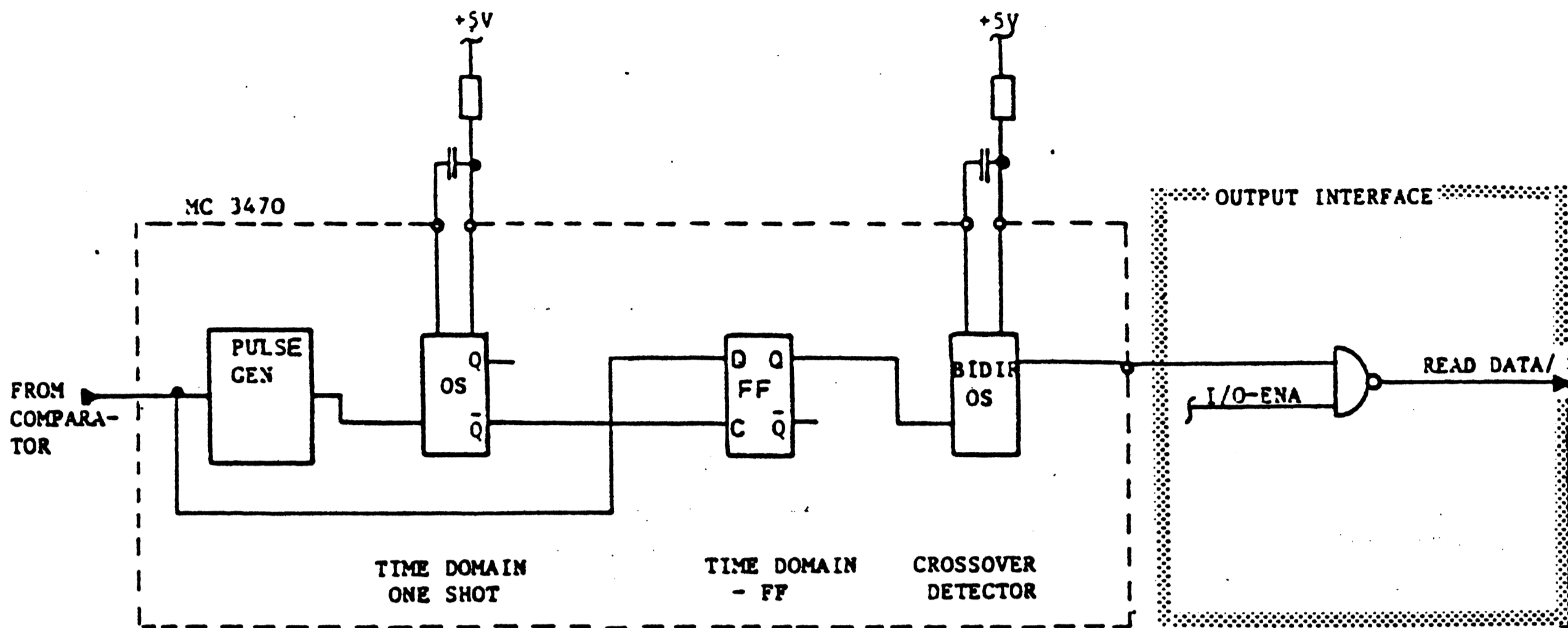

FIGURE 2 - 39 TIME DOMAIN FILTER AND CROSSOVER DETECTOR

2.2.10.6 TIMING DIAGRAM READ CIRCUITS

Fig. 2-40 is a timing diagram of the read circuits and illustrates the functions described above.

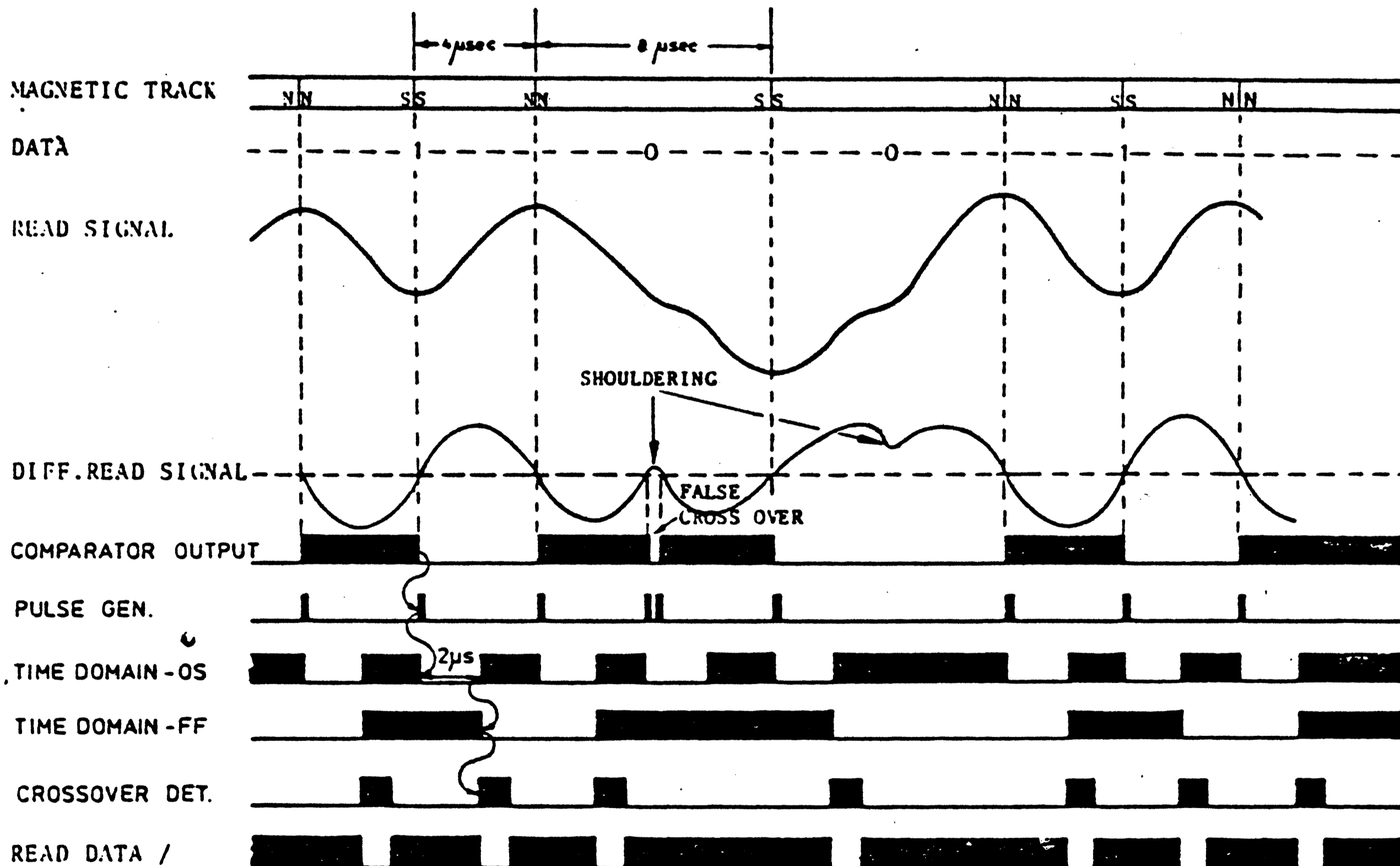

FIGURE 2 - 40 TIMING DIAGRAM READ CIRCUITS

2.2.11 DC-CONTROL AND POWER ON RESET LOGIC

2.2.11.1 DC-CONTROL

The DC-control logic is shown on Fig. 2-41. This logic monitors the DC-voltages + 5 V and + 12 V and disables the write and erase current source, if one of these voltages is missing or out of the following limits:

If + 5 V falls below + 4.7 V, DC-CONTROL goes high and disables T2.

If + 12 V falls below + 9 V, T2 is also blocked and the write and erase current inhibited.

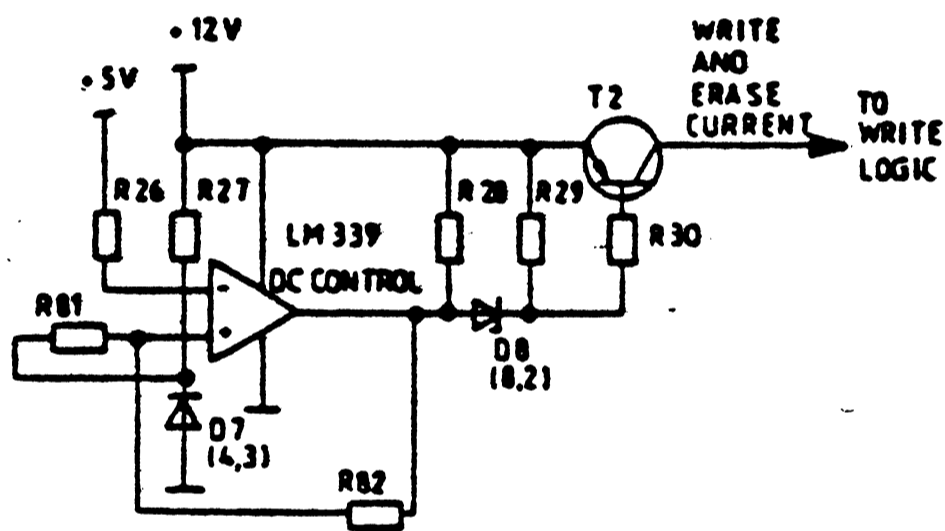

FIG. 2 - 41 DC-CONTROL LOGIC

2.2.11.2 POWER ON RESET LOGIC

The power on reset logic is shown on Fig. 2-42. As the + 5 V energizes the capacitor begins to charge towards + 3 V. As long as the capacitor voltage is lower than the threshold voltage V_{th} of the driver gate the PWRONRESET/-signal is held low, thus a 40 msec logic initialization pulse is developed (see Fig. 2-43). The PWRONRESET/-pulse provides the following:

- Resets the ERASE OFF Delay One Shot.
- Resets the Ready Detector Logic.
- Resets the IN USE-FF.

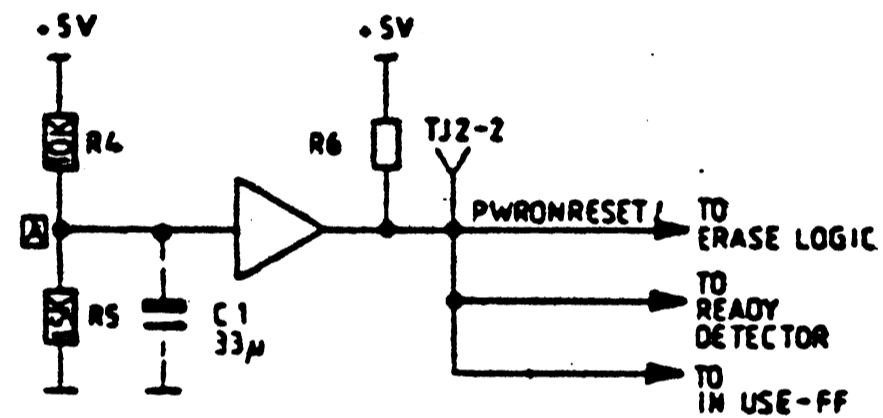

FIG. 2 - 42 POWER ON RESET LOGIC

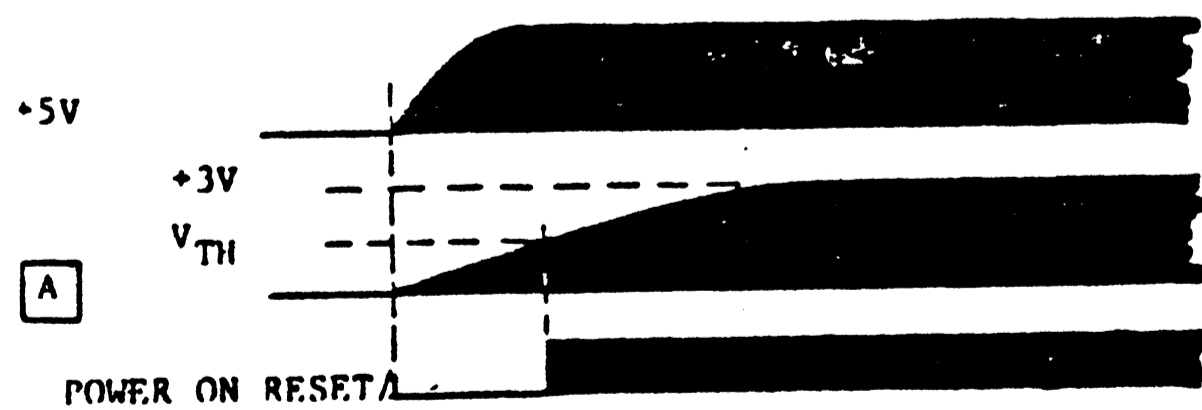

FIG. 2 - 43 TIMING DIAGRAM POWER ON RESET

SECTION 3

INSTALLATION AND OPERATION

3.1 INSTALLATION

3.1.1 GENERAL

This section provides information for installation and configuration of the mini disk drive.

3.1.2 UNPACKING AND INSPECTION

The mini disk drive is packaged in a heavy duty container, designed to ensure adequate protection during shipping and handling (see Fig. 3-1). When the mini disk drive is installed, store the container and all packing material for possible future use. Use the following procedure during unpacking and inspection:

- Remove contents of shipping container and inspect for in-transit damage. If damage is evident, notify the carrier and BASF. Specify nature and extent of damage.
- Verify that content of shipping container agrees with shipping list. Notify a BASF representative if anything is missing.
- Verify that model designation and serial number agree with those on the shipping invoice.
- Inspect assemblies for loose hardware. Tighten hardware if necessary.

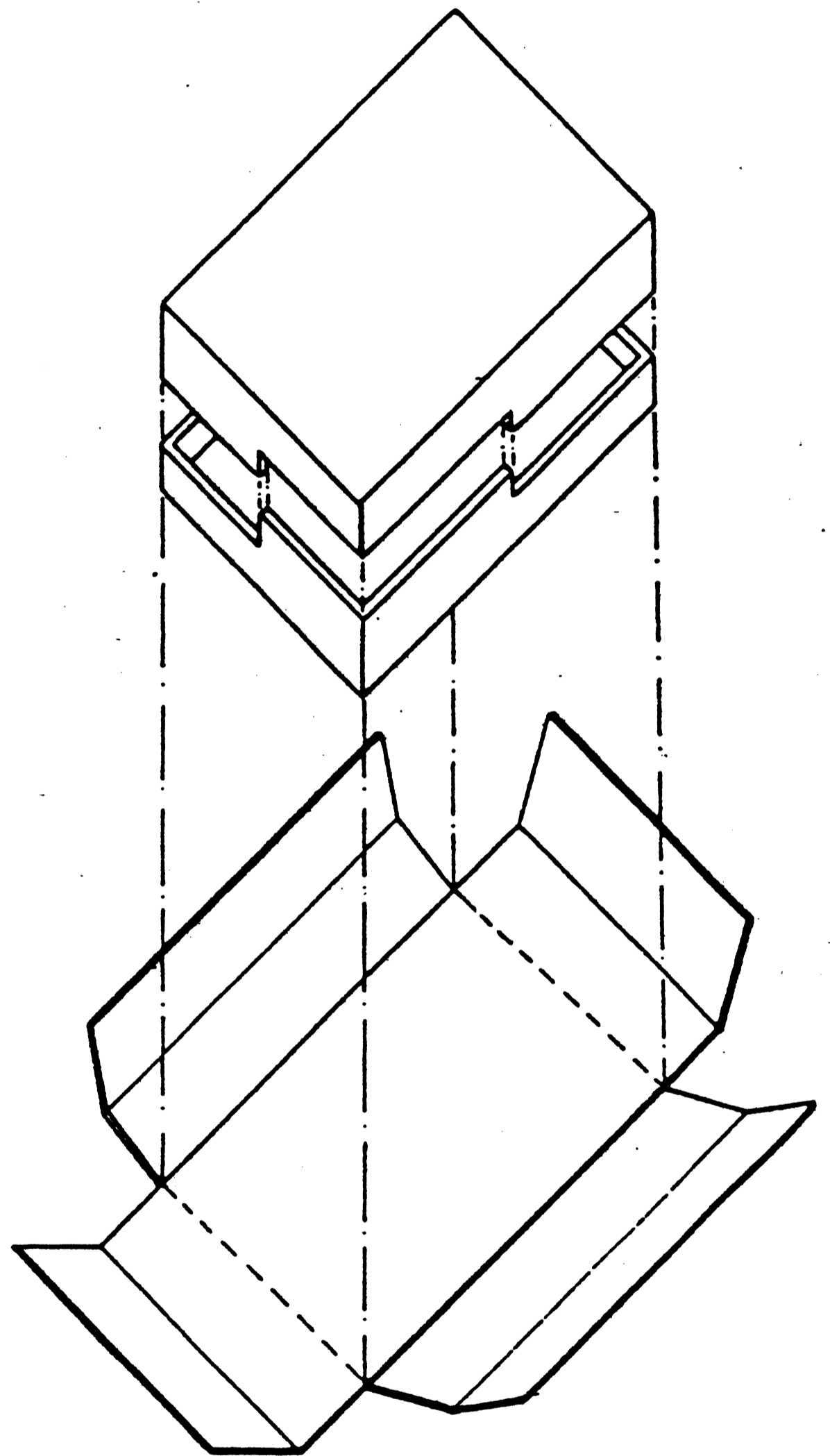

FIG. 3 - 1 SHIPPING CONFIGURATION

3.1.3 CONNECTING CABLES

The mini disk drive is connected to the host system by two connecting cables, the DC-cable and the interface cable. The DC-cable requires direct connection to each drive, regardless of connecting configuration. The interface cable is connected to the various connecting configurations (see 3.1.6) and should not exceed 10 feet in length.

3.1.4 CONNECTORS

3.1.4.1 DC-CONNECTOR

DC power is connected to the disk drive through connector J5. The input pin assignments and voltage requirements are listed in table 3-1.

PIN No.	DC VOLTAGE	TOLERANCE	CURRENT	MAX. RIPPLE (p - p)
1	+ 12 V	$\pm 0.6 V$	^{+) 1.75A}	100 mV
2	+ 12V RET	-	-	-
3	+ 5V RET	-	-	-
4	+ 5 V	$\pm 0.25V$	0.7 A	50 mV

^{+) Plus 0.65 A motor starting current for max. 50 msec.}

Voltages to be measured on testpoints on drive PCB.

TABLE 3 - 1 DC-POWER REQUIREMENTS

The return lines for + 12V and + 5V (pins 2 and 3) should be separate lines and must be connected together in the system. DC power input connector J5 is mounted on the component side of the PCB beside the stepper motor (see Fig. 3-9). The 4 pin connector is BASF P/N 88359-001 (see Fig. 3-2) and is soldered directly to the PCB. The recommended mating connector is AMP P/N 1-480424-0 using pins P/N 60619-1.

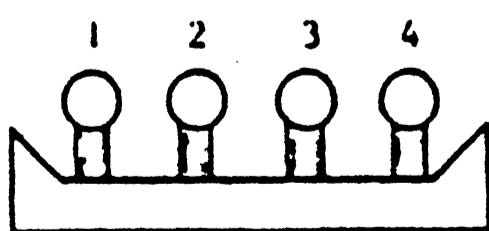

FIG. 3 - 2 DC-CONNECTOR

3.1.4.2 SIGNAL CONNECTOR

The signal cable is connected to the mini disk drive through connector J1. Connector J1 is a 34 pin PCB edge card connector located at the rear of the disk drive. The pins are numbered from 1 to 34 with the even pins on the component side. Pin 2 is located closest to the stepper motor and is marked. A keyslot is provided between pins 4 and 6 for optional connector keying. Recommended mating connectors for J1 are listed in Table 3-2.

CABLE TYPE	MANUFACTURER	CONNECTOR P/N	CONTACT P/N
FLAT CABLE	SCOTCHFLEX	3463-0000	NA
		3463-0001	NA
TWISTED PAIR # 26	AMP	583717-5	1-583616-1

TABLE 3 - 2 RECOMMENDED J1 MATING CONNECTORS

3.1.4.3 FRAME CONNECTOR

The mini disk drive must be frame grounded to the host system to insure proper operation. A fast on tab is provided on the drive near to the stepper motor. A fast on connector with AC ground from the host system can be attached or soldered if the mini disk drive is not fastened directly to the frame of the host system with a good AC ground. The tab is Grothe-Hartmann 17312 and its mating connector is Grothe-Hartmann 123211.

3.1.4.4 INTERCONNECTING DIAGRAM

Fig. 3-3 is provided as an interconnecting diagram showing the connections directly to or from the PCB. Connectors J2, J3 and J6 are for internal drive use, connector J1 and J5 are from the controller.

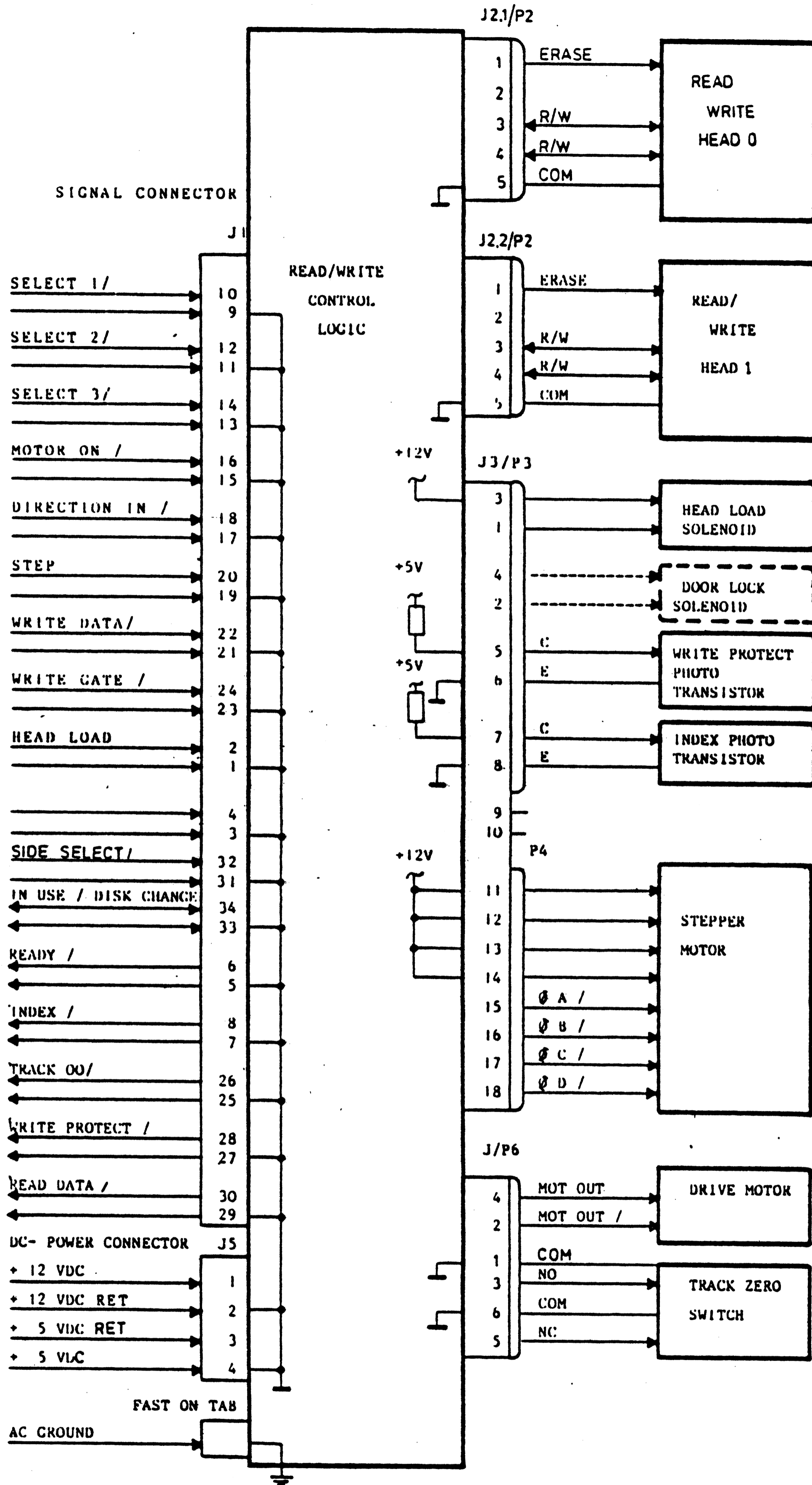

FIGURE 3 - 3 INTERCONNECTING DIAGRAM

3.1.5 LOGIC LEVELS AND TERMINATION

Interface signals to and from connector J1 have the logic levels represented by Fig. 3-4. All signal inputs are terminated by a $150\ \Omega$ resistor network chip (position 4D). This chip can be removed for a daisy chain configuration where only the last mini disk drive needs a termination network.

The BASF 6106/08 uses SN 7438 or equivalent as output driver. As input receiver SN 7404 or equivalent is used. Fig. 3-5 shows the recommended interface logic.

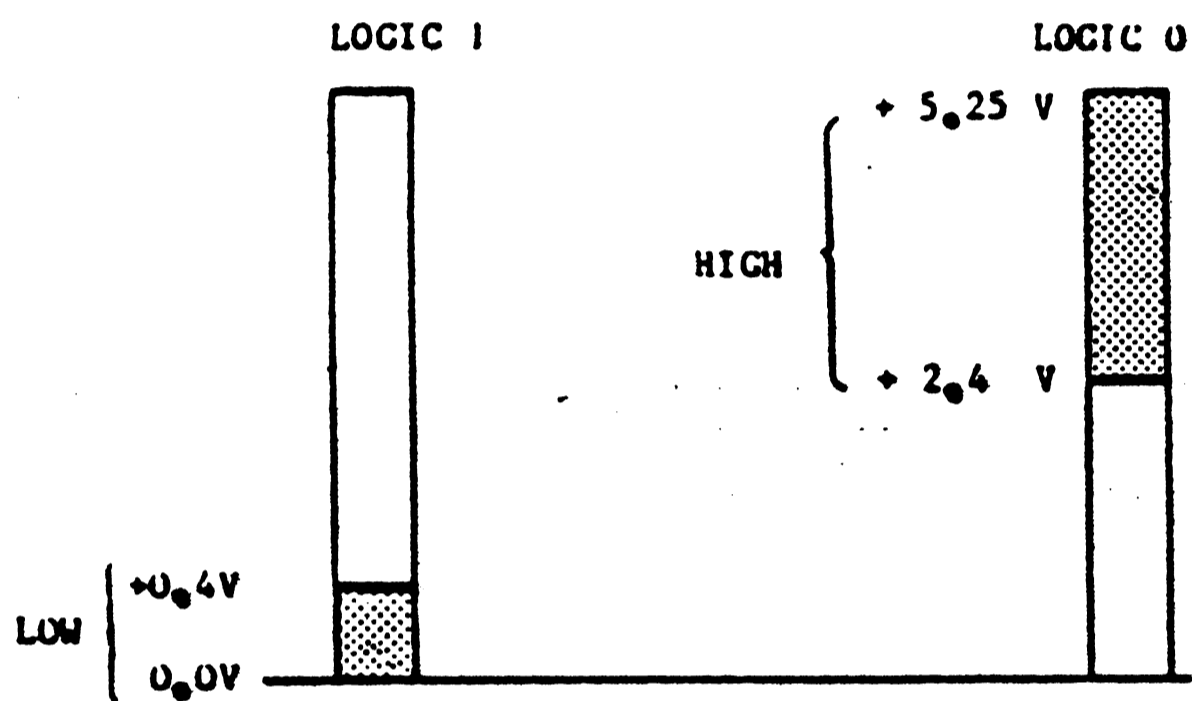

FIG. 3 - 4 INTERFACE LOGIC LEVELS

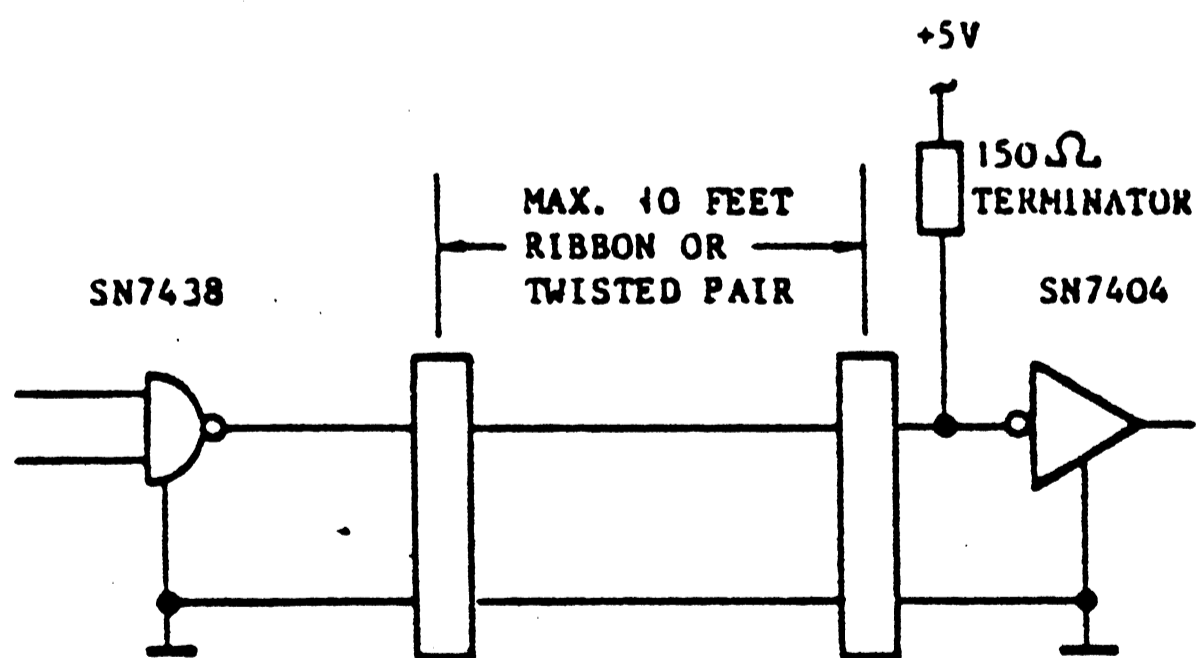

FIG. 3 - 5 RECOMMENDED DRIVER / RECEIVER CIRCUIT

3.1.6 CONNECTING CONFIGURATION

The BASF 6106/6108 can be connected to the host system in different configurations:

- Single Drive Configuration
- Multi Drive Configuration

3.1.6.1 SINGLE DRIVE CONFIGURATION

Only one drive is connected to the host system as shown in Fig. 3-6.

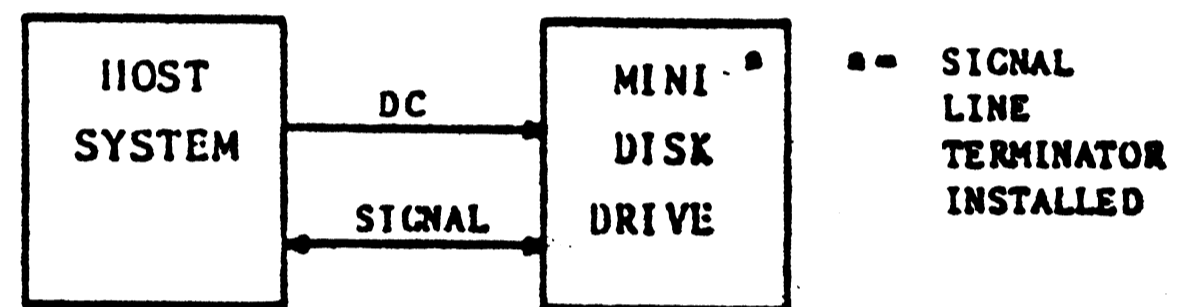
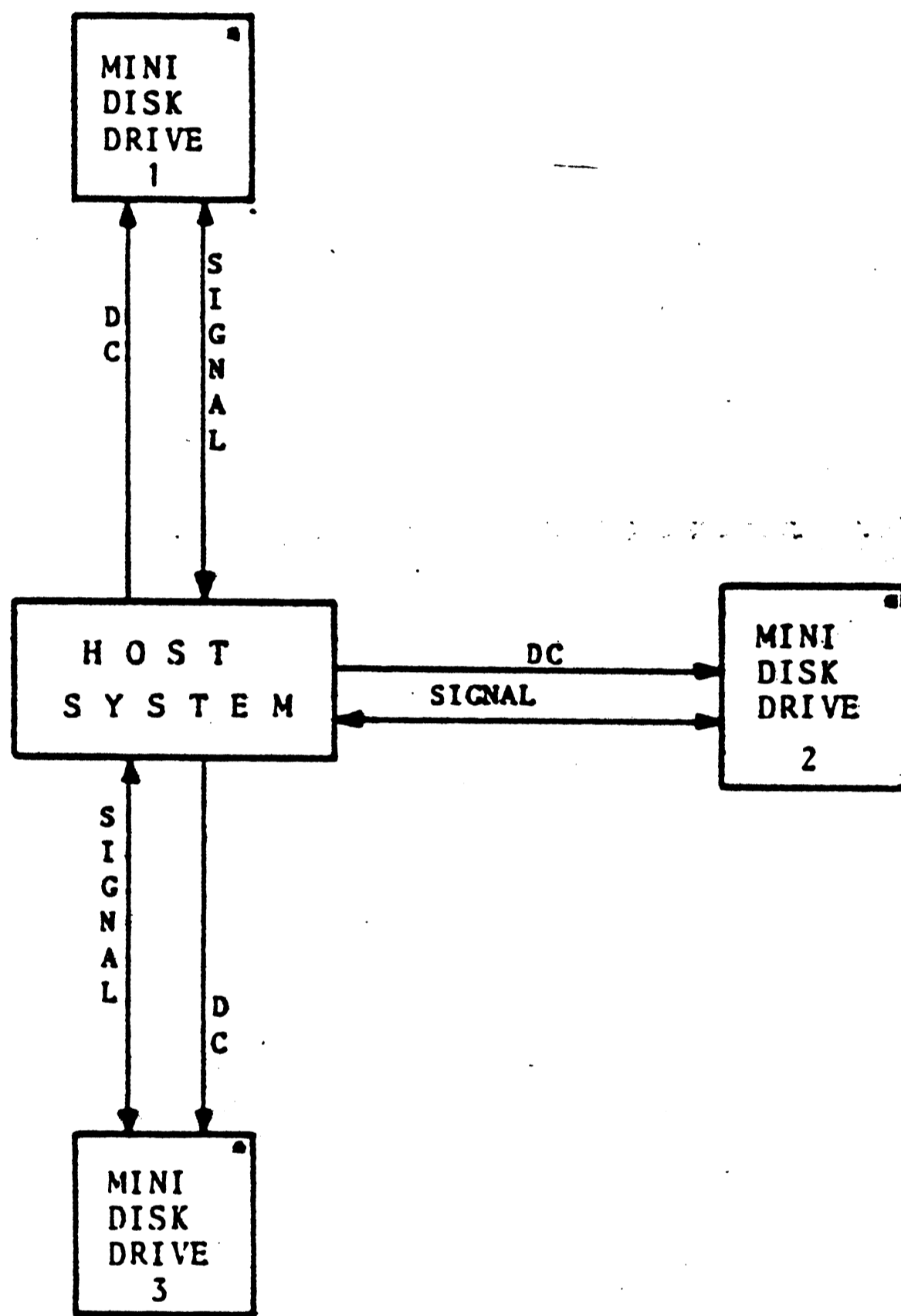

FIG. 3 - 6 SINGLE DRIVE CONFIGURATION

3.1.6.2 MULTIPLE DRIVE CONFIGURATION

In multi drive configurations more than one drive is connected to the host system. In a multi drive configuration the BASF 6106 can be connected in radial select or daisy chain fashion (see Fig. 3-7 and 3-8).

In a radial select configuration all mini disk drives need terminator networks and in a daisy chain configuration only the last drive needs a terminator chip.



* SIGNAL LINE TERMINATOR

FIG. 3 - 7 RADIAL SELECT CONFIGURATION

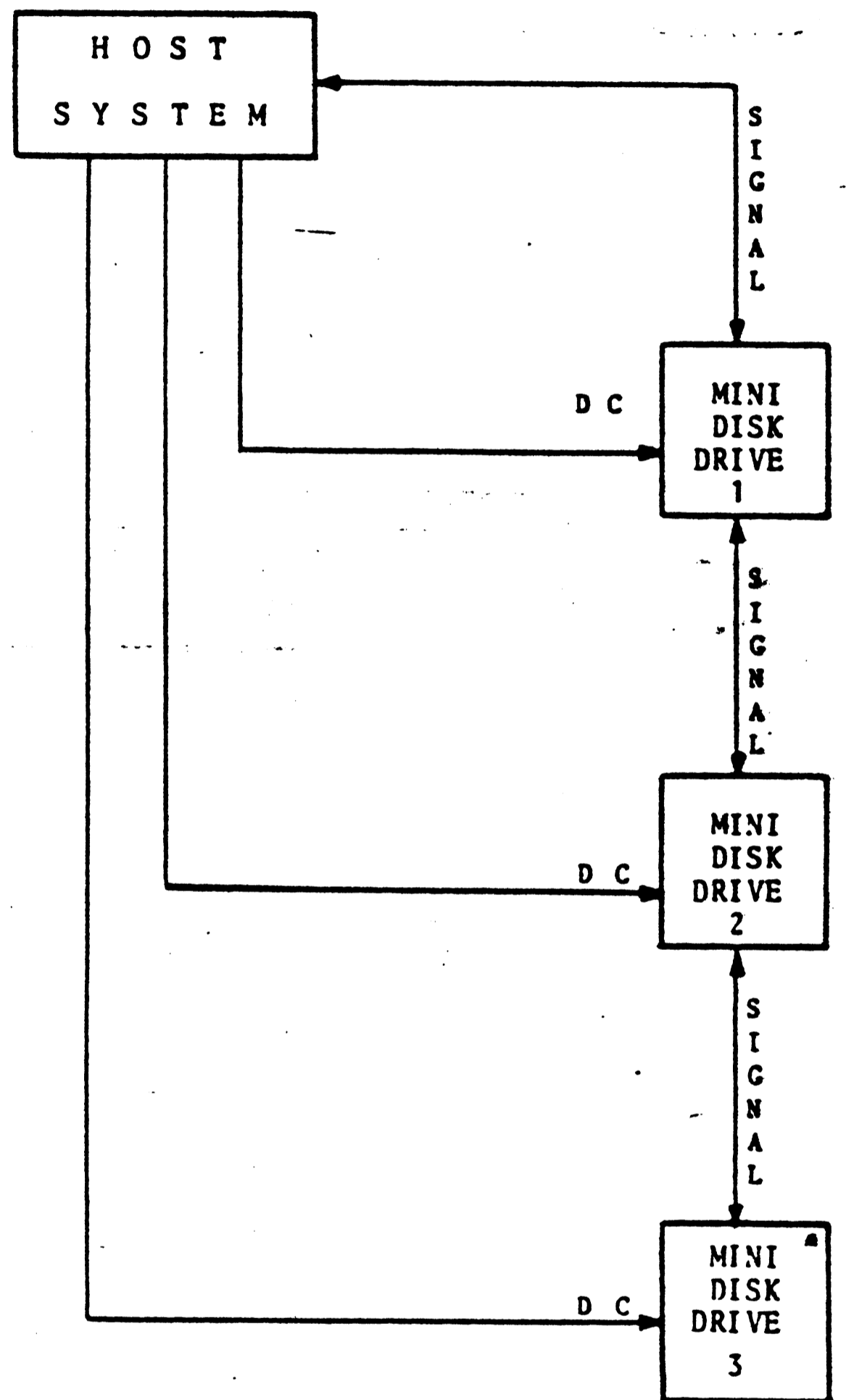

* SIGNAL LINE TERMINATOR

FIG. 3 - 8 DAISY CHAIN SELECT CONFIGURATION

3.1.7 SELECTION OF THE DESIRED OPTIONS

3.1.7.1 SELECT OPTIONS

In a single drive configuration the Auto Select Option will be used, in a multi drive configuration the Radial Select Option must

JUMPER		JJ-1			JJ-2	
		1-2	3-4	5-6	5-6	7-8
OPTION						
AUTO SELECT						X
RADIAL SELECT	DRIVE #1	X			X	
	DRIVE #2		X		X	
	DRIVE #3			X	X	

X = Jumper installed

TABLE 3 - 3 SELECT OPTIONS JUMPERING

3.1.7.2 HEAD LOAD OPTIONS

There are three Head Load Options:

- AUTO HEAD LOAD
HEAD LOAD = INT. SELECT
- SELECTED HEAD LOAD
HEAD LOAD = INT.SELECT-HEAD LOAD
- RADIAL HEAD LOAD
HEAD LOAD = HEAD LOAD

JUMPER		JJ-2			JJ-3
		1-2	3-4	9-10	13-14
OPTION					
AUTO HEAD LOAD		X			X
SELECTED HEAD LOAD		X		X	
RADIAL HEAD LOAD			X	X	

TABLE 3 - 4 HEAD LOAD OPTION JUMPERING

3.1.7.3 IN USE / DISK CHANGE OPTION

Pin 34 of the interface can be used as IN USE (INPUT) or DISK CHANGE (OUTPUT) (see Table 3-5).

OPTION	JUMPER	
	JJ-2	
	11-12	13-14
IN USE OPTION		X
DISK CHANGE OPTION	X	

TABLE 3 - 5 IN USE / DISK CHANGE OPTION JUMPERING

3.1.7.4 DOOR LOCK OPTIONS

Locking of the door can be accomplished by the following conditions shown in Table 3-6.

JUMPER		JJ-3				JJ-4	
		1-2	7-8	9-10	11-12	9-10	11-12
DOOR LOCK= IN USE *		X		X		X	
" = I/O ENA			X				
" = HDLOAD ENA					X		
" = IN USE + * IN USE FF		X		X		X	
" = IN USE + * I/O ENA		X	X			X	
" = IN USE + * IN USE FF + I/O ENA		X	X			X	X
" = IN USE + * HDLOAD		X			X	X	
" = IN USE + * IN USE FF + HDLOAD		X			X	X	X

* IN USE OPTION must be installed!

TABLE 3 - 6 DOOR LOCK OPTIONS JUMPERING

3.1.7.5 ACTIVITY LED OPTIONS

The activity LED can be switched on by the following conditions shown in Table 3-7.

OPTION \ JUMPER		.11-4	
		5-6	7-8
ACTIVITY LED	HEAD LOAD ENA • SPEED		X
ACTIVITY LED	DOOR LOCK • SPEED	X	

TABLE 3 - 7 ACTIVITY LED OPTION JUMPERING

3.1.7.7 STEPPER MOTOR SWITCHING

If the stepper motor shall be enabled by the MOTOR ON signal the following jumper must be installed (see Table 3-9).

OPTION \ JUMPER		11-4
		1-2
STEP MOTOR ENABLE	MOTOR ON	X

TABLE 3 - 9 STEPPER MOTOR SWITCHING OPTION JUMPERING

3.1.7.6 WRITE PROTECT OPTION

The manner in which the mini disk is write protected can be selected by jumpers as shown in Table 3-8.

OPTION \ JUMPER		.11-3		.11-4
		3-4	5-6	3-4
WRITE PROTECT	NOTCH COVERED		X	X
WRITE PROTECT	NOTCH OPEN	X		

TABLE 3 - 8 WRITE PROTECT OPTION JUMPERING

3.1.7.8 JUMPER MATRIX

Table 3-10 provides a Jumper Matrix for all Options. For selecting the desired jumpers provide the following:

- Select one of the SELECT options and install the jumpers
- Select one of the Head Load options and install the jumpers
- Select In Use or Disk Change option.
- Select one of the Door Latch options, if door locking or activity LED is used. Install the jumpers.
- Select one of the Activity LED options and install the jumpers.
- Select one of the Write Protect options and install the jumpers.
- Install the Stepper Motor Switching Jumper if desired.

For location of jumpers refer to Fig. 3-9.

OPTION		JUMPER	JJ-1			JJ-2				JJ-3				JJ-4				
			1-2	3-4	5-6	1-2	3-4	5-6	7-8	9-10	11-12	13-14	1-2	3-4	5-6	7-8	9-10	11-12
SELECT OPTIONS	AUTO SELECT																	
	DRIVE # 1		X															
	RADIAL SELECT			X														
HEAD LOAD OPTIONS	DRIVE # 2				X													
	DRIVE # 3					X												
	AUTO HEAD LOAD																	
HEAD LOAD OPTIONS	SELECTED HEAD LOAD																	
	RADIAL HEAD LOAD																	
	DISK CHANGE OPTION																	
In Use Option	IN USE OPTION																	
DOOR LOCK OPTIONS	DOOR LOCK = IN USE																	
	" = I/O ENA																	
	" = HDLOAD ENA																	
	" = IN USE + IN USE- FF																	
	" = IN USE + I/O ENA																	
	" = IN USE + IN USE- FF + I/O ENA																	
	" = IN USE + HDLOAD																	
ACTIVITY LED OPTIONS	ACT. LED = IN USE- FF + HDLOAD																	
	ACT. LED = DOOR LOCK + SPEED																	
WRITE PROT. OPTIONS	WRITE PROT. = NOTCH COVERED																	
	WRITE PROT. = NOTCH OPEN																	
STEP.MOT.	STEP. MOT. ENA = MOTOR ON																	

TABLE 3 - 10 OPTION JUMPER MATRIX

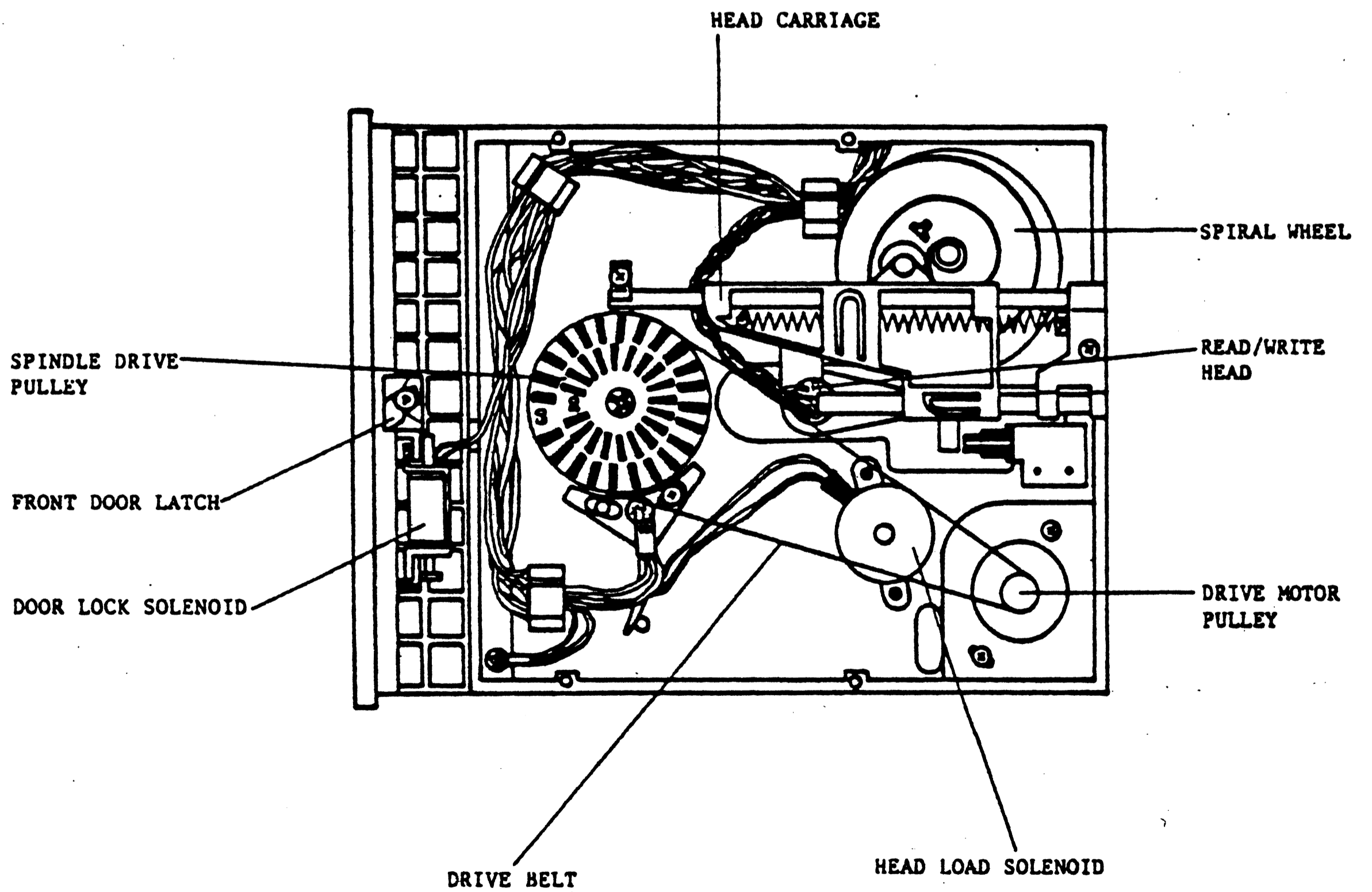
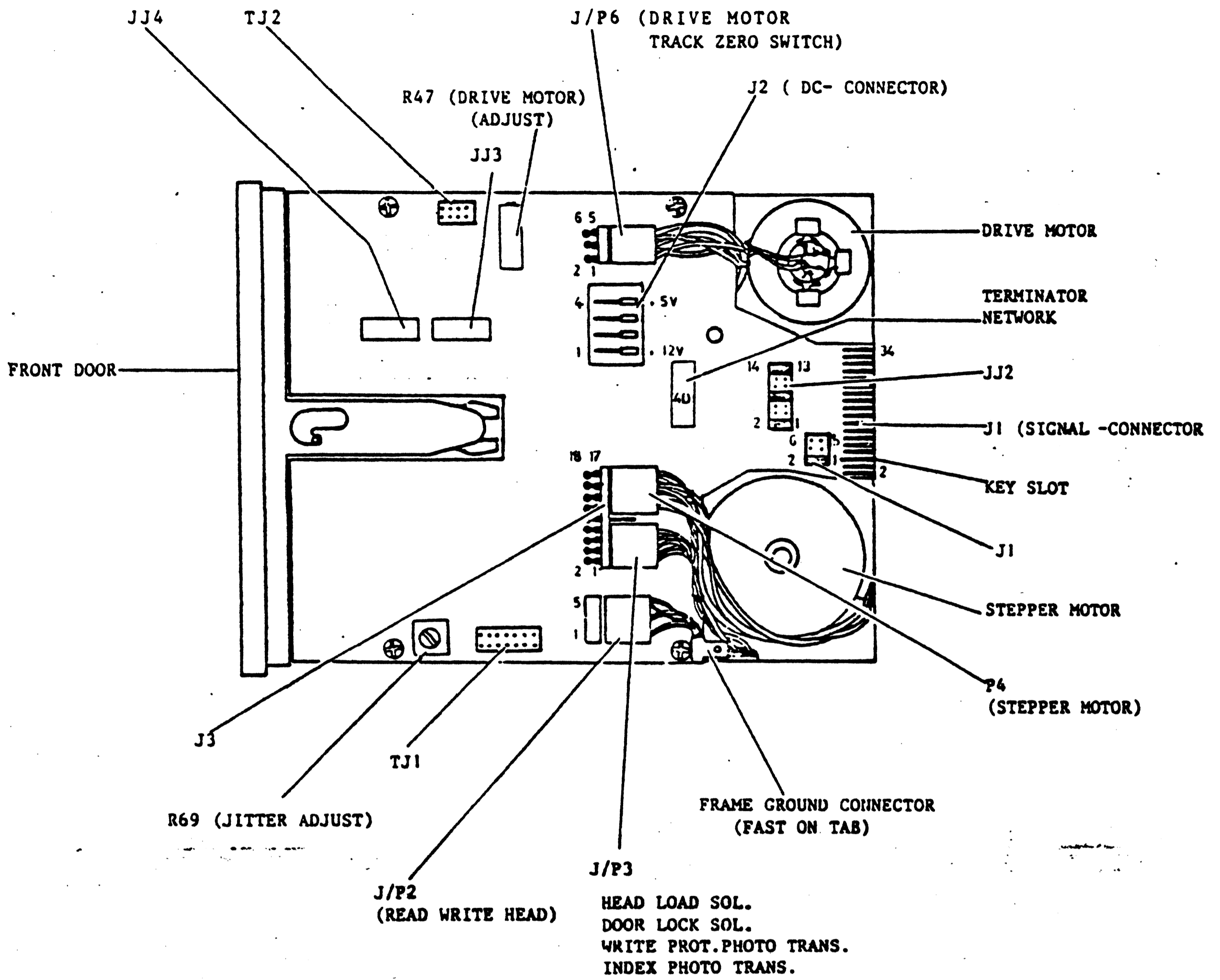

FIGURE 3 - 9 . PART LOCATIONS (PRINZIPAL)

3.1.8 DRIVE MOUNTING

3.1.8.1 MOUNTING POSITIONS

The mini disk drive may be mounted in any position.

3.1.8.2 MOUNTING DIMENSIONS

Figure 3-10 shows the outline and mounting dimensions of the mini disk drive. For more detailed information see Specification of the BASF 6106/6108 mini disk drives.

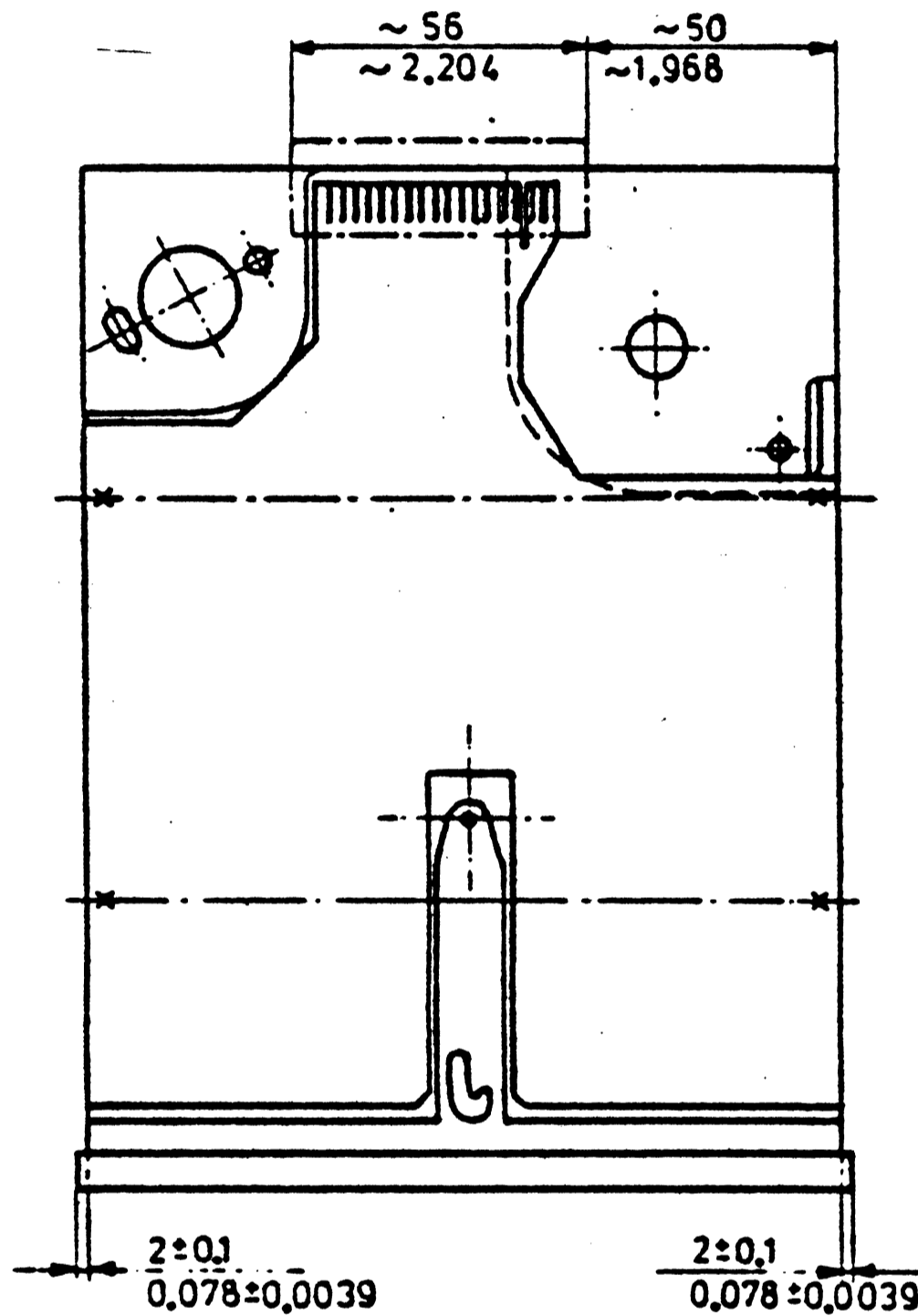
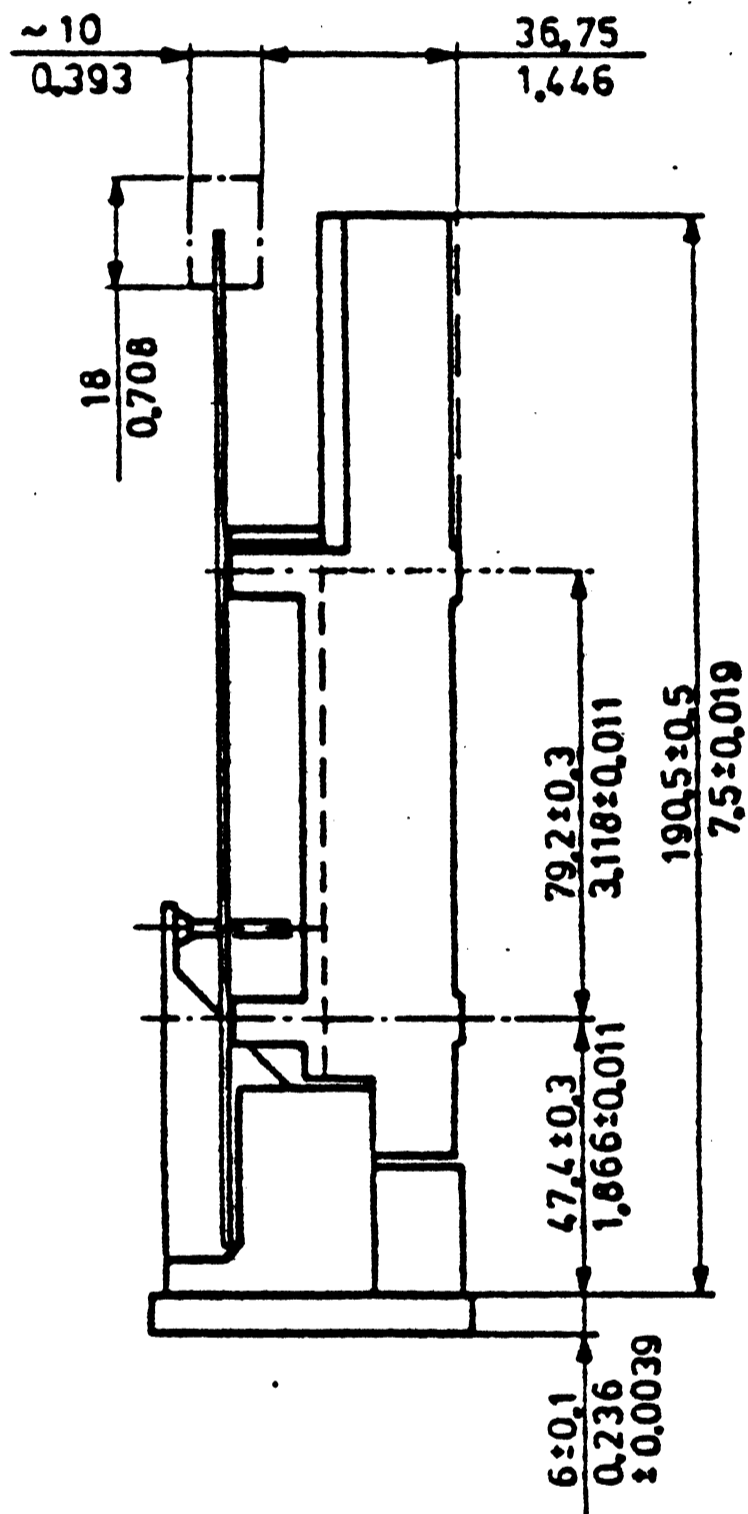
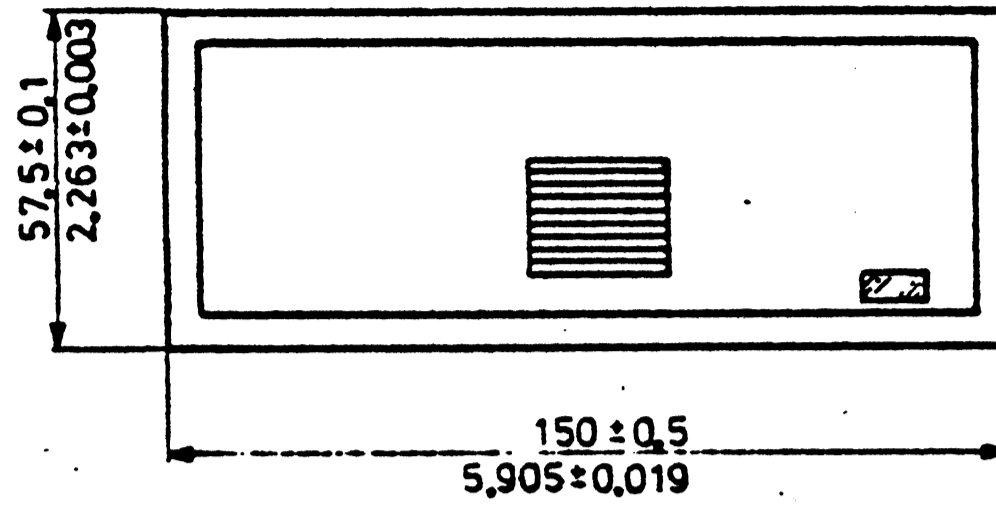

DIMENSIONS IN

mm
(inch)

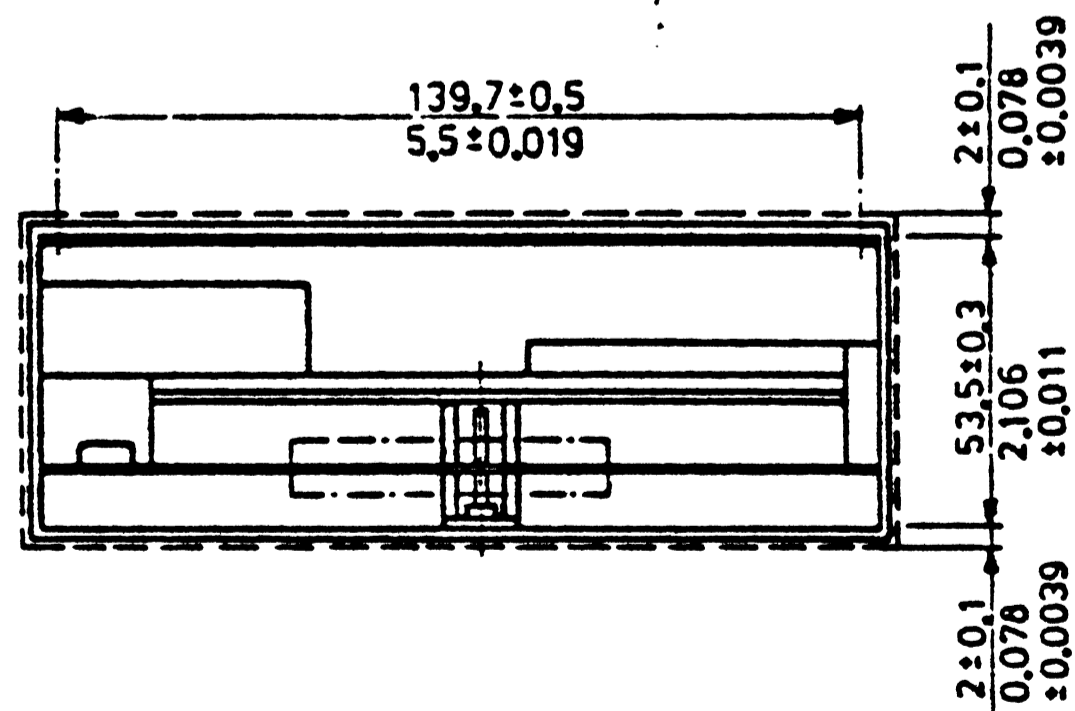

FIGURE 3 - 10 MOUNTING SPECIFICATION

3.2 OPERATION

3.2.1 GENERAL

There are no front panel controls on the BASF 6106/6108. All power and control functions are handled through the interface. Operating procedures consist primarily of loading and unloading the mini disk.

3.2.2 MINI DISK STORAGE AND HANDLING

The following are essential requirements for mini disk storage and handling:

- The mini disk should be stored in an environment that is clean and free from any magnetic influence.
- The mini disk should be in same temperature and humidity environment as the disk drive for a minimum of five minutes prior to use.
- Return Flexy Disk to protective envelope when not in use.
- Never place heavy objects on the mini disk cartridge.
- Never touch the Flexy Disk through the cartridge opening when handling.
- Never attempt to clean the Flexy Disk.
- Do not bend or fold the Flexy Disk.
- Do not use rubber bands or paper clips on the Flexy Disk.
- Never write on cartridge (use labels).
- Do not expose Flexy Disk to excessive heat or sunlight.

Proper loading of the mini disk is vital to the operation of the mini disk and drive. Fig. 3-11 shows the proper loading of the mini disk.

Procedures for loading and unloading the mini disk drive are given in Tables 3-11 and 3-12, respectively.

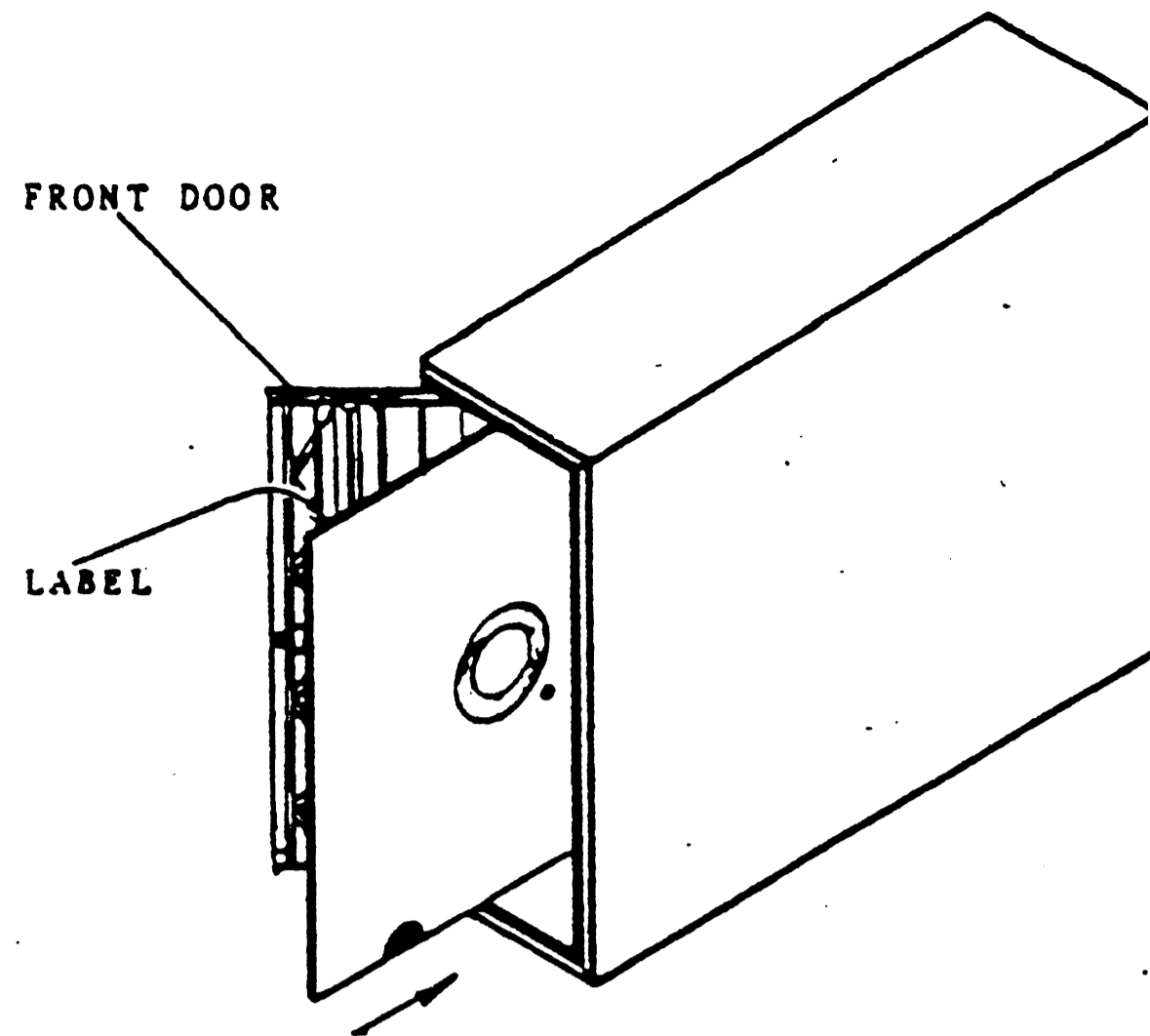

Caution: insert fully before closing the front door!

FIGURE 3 - 11 FLEXY DISK LOADING

STEP	ACTION
1	Press front door and release to open
2	Insert Flexy Disk fully with label towards front door
3	Close front door

TABLE 3 - 11 FLEXY DISK LOADING

STEP	ACTION
1	Press front door and release to open
2	Remove Flexy Disk

TABLE 3 - 12 FLEXY DISK UNLOADING

3.2.3 WRITE PROTECT

There are two methods used to protect a Flexy Disk from being written:

- a) Write Protect if Notch open (optional)
- b) Write Protect if Notch covered (ECMA)

3.2.3.1 WRITE PROTECT IF NOTCH OPEN (OPTIONAL)

Jumper: JJ3 : 3-4

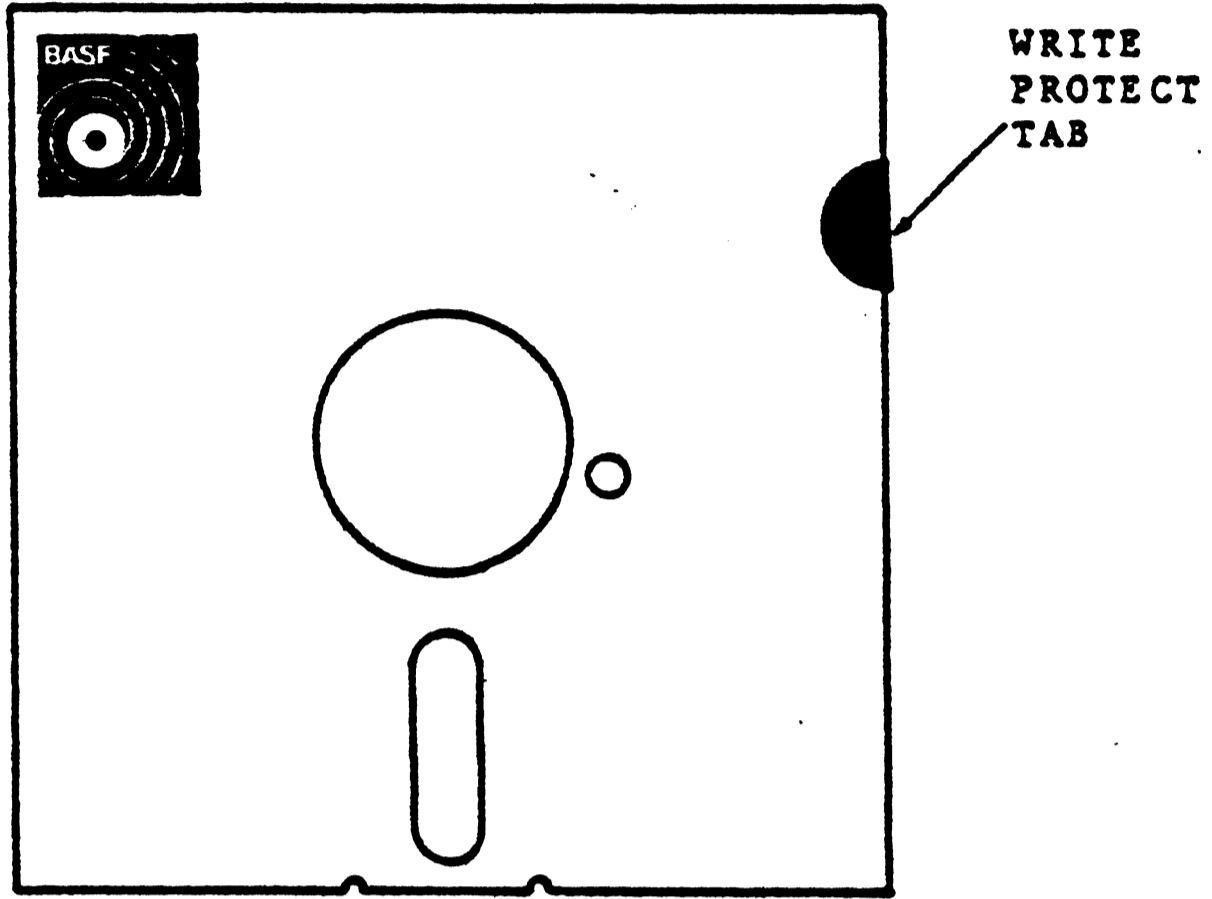

UNPROTECTED

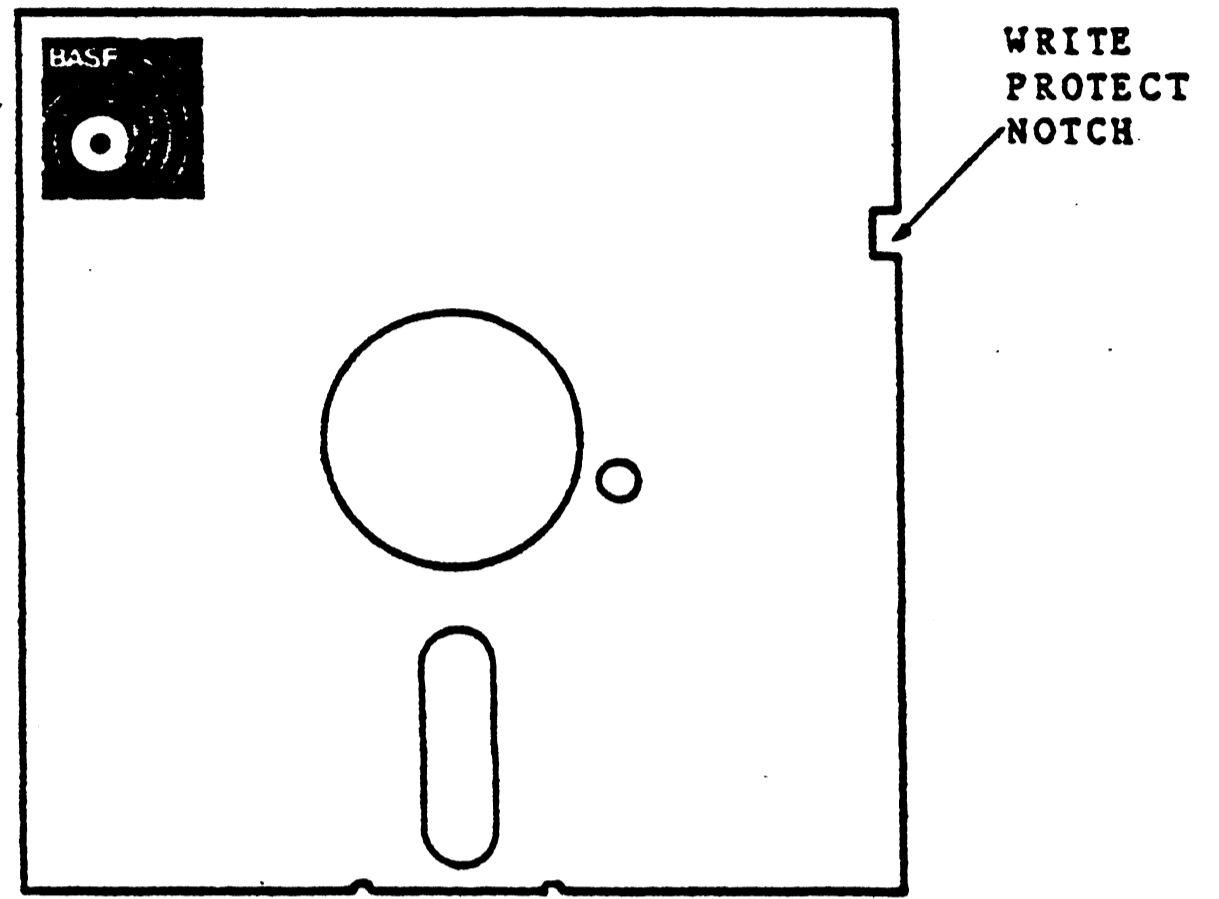

WRITE PROTECTED

FIGURE 3 - 12 WRITE PROTECT FEATURE (OPTIONAL)

3.2.3.2 WRITE PROTECT IF NOTCH COVERED (ECMA)

Jumper: JJ3 : 5-6

JJ4 : 3-4

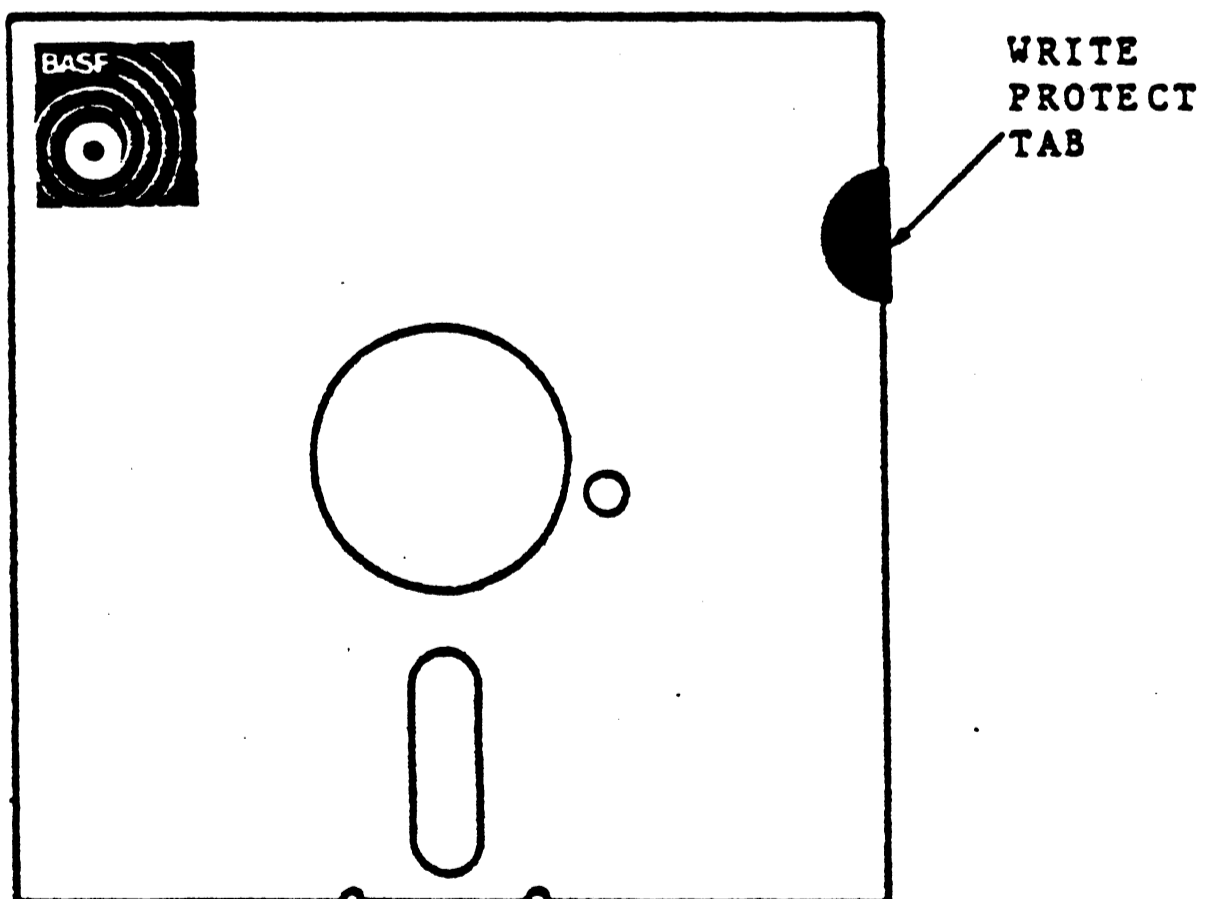

WRITE PROTECTED

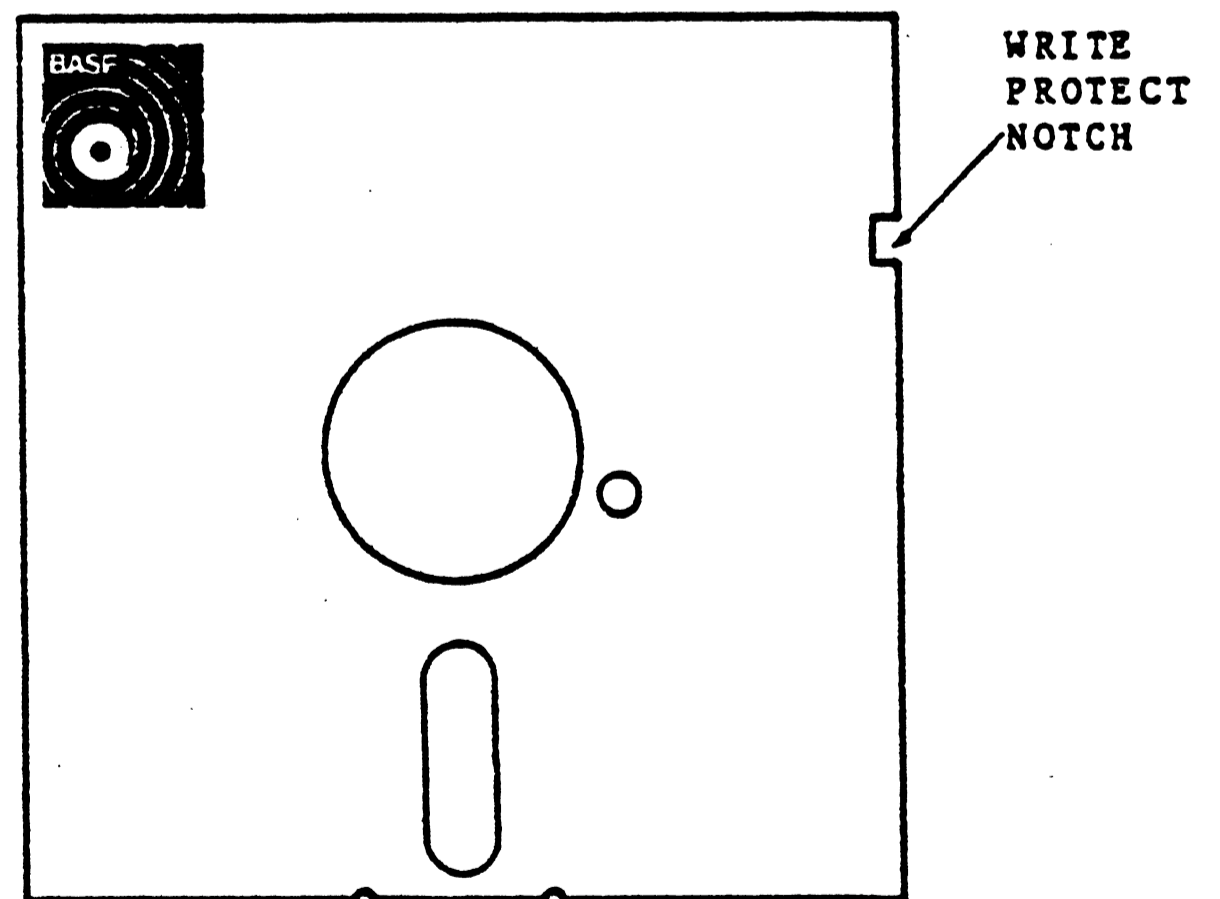

UNPROTECTED

FIGURE 3 - 13 WRITE PROTECT FEATURE (ECMA)

SECTION 4

MAINTENANCE

4.1 GENERAL

This section contains the procedures for performing operational checks, alignments and adjustments for the BASF 6106 and BASF 6108 mini disk drives.

The BASF 2007 exerciser is a portable unit to operate the mini disk drive off-line. The BASF 2007 will enable the user to make all adjustments and checks required on the BASF 6106 and BASF 6108 mini disk drives. The exerciser is provided with controls and indicators to execute all control operations and simulate and read and write operations.

4.2 TOOLS AND TEST EQUIPMENT

To perform proper maintenance of the mini disk drive, certain tools, test equipment and supplies are required. A list of standard tools and test equipment is provided in table 4-1. Special tools and test equipment are listed in table 4-2.

BASF - CE - Mini Disk
BASF - CLEANING Mini Disk
Exerciser BASF 2007
Dial Gauge (Belt Tension Tool)

Common hand tools
Freon
Cotton tipped swabs (Q-tips)
Soft lint free cloth (gauze)
Voltohmeter
Oscilloscope
Inspection Mirror
Frequency Counter

TABLE 4 - 2 SPECIAL TOOLS AND TEST EQUIPMENT

TABLE 4 - 1 STANDARD TOOLS AND TEST EQUIPMENT

4.3. CHECKS, ADJUSTMENTS AND REPLACEMENTS

4.3.1 PCB REPLACEMENT

- a) Turn off DC voltages.
- b) Remove P 1, P 2, P 3, P 4, P 5, P 6.
- c) Remove the 4 mounting screws.
- d) To reinstall, reverse the above.
- e) Check and readjust the Index-detector.
- f) Readjust the drive motor speed and jitter, if a new PCB was installed.

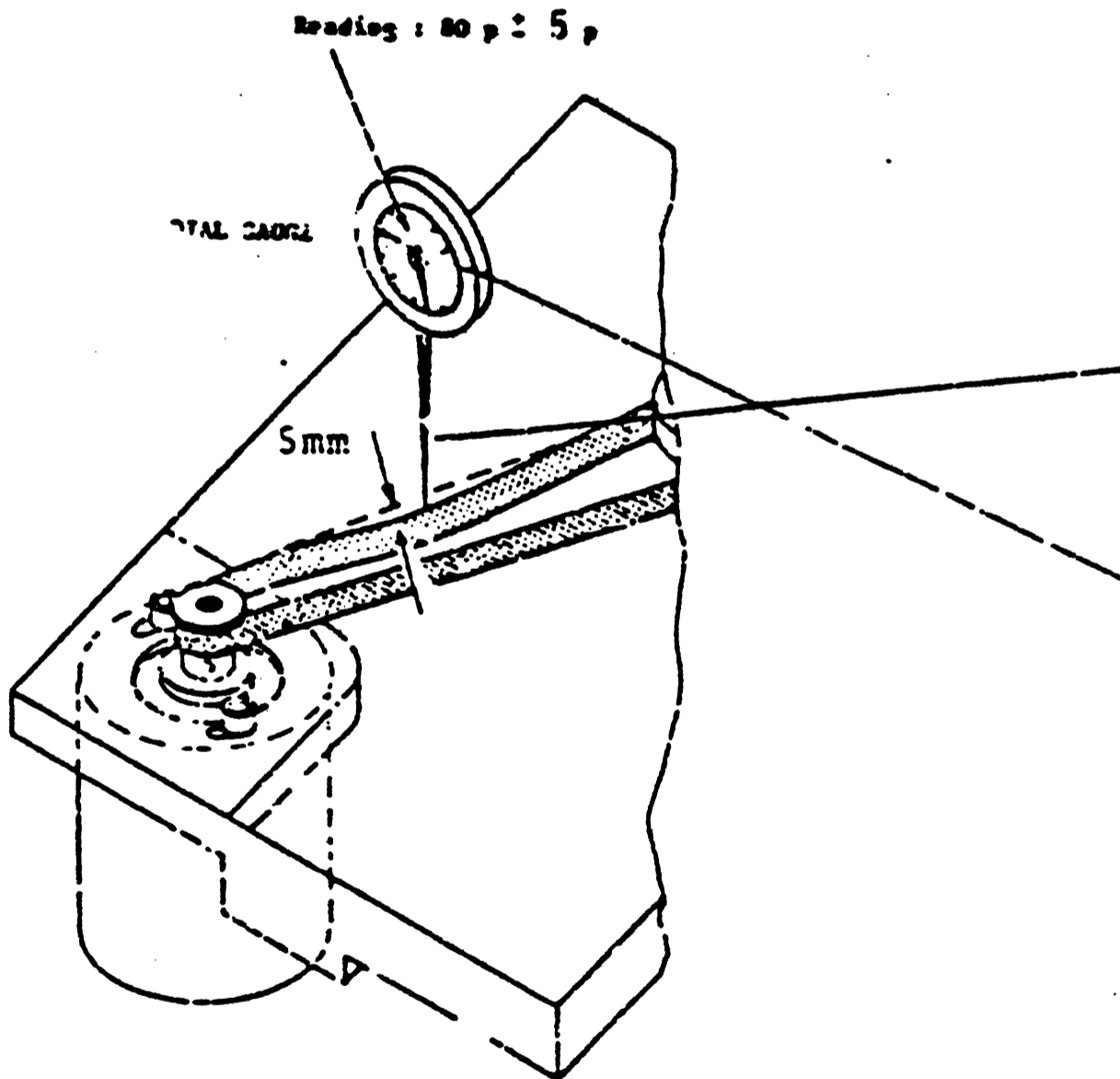

4.3.2 SPINDLE DRIVE SYSTEM

The spindle drive system consists of the drive motor, the drive motor pulley, the spindle drive belt and the spindle drive pulley.

4.3.2.1 DRIVE MOTOR AND DRIVE BELT CHECKS

- a) Turn off the DC input power.
- b) Rotate drive motor manually and inspect drive belt for wear, cracks or fraying edges. Replace drive belt, if necessary.
- c) Rotate motor manually and inspect for bearing noise or binding. Replace drive motor, if necessary.
(Ref. to Drive Motor Replacement Procedure)
- d) Turn on DC power to mini disk drive.
- e) Start drive motor (MOTOR ON/active).
- f) Verify that drive motor and drive belt operate normally and that drive belt tracks evenly and smoothly in center of both pulleys.

4.3.2.2 DRIVE BELT TENSION CHECK

- a. Take a dial gauge and press it against the drive belt until the deflection of the belt is 5 mm.
- b. The reading on the gauge must be $\sim 80 p \pm 5 p$.
- c. If the measured value is out of limits perform drive belt tension adjustment.

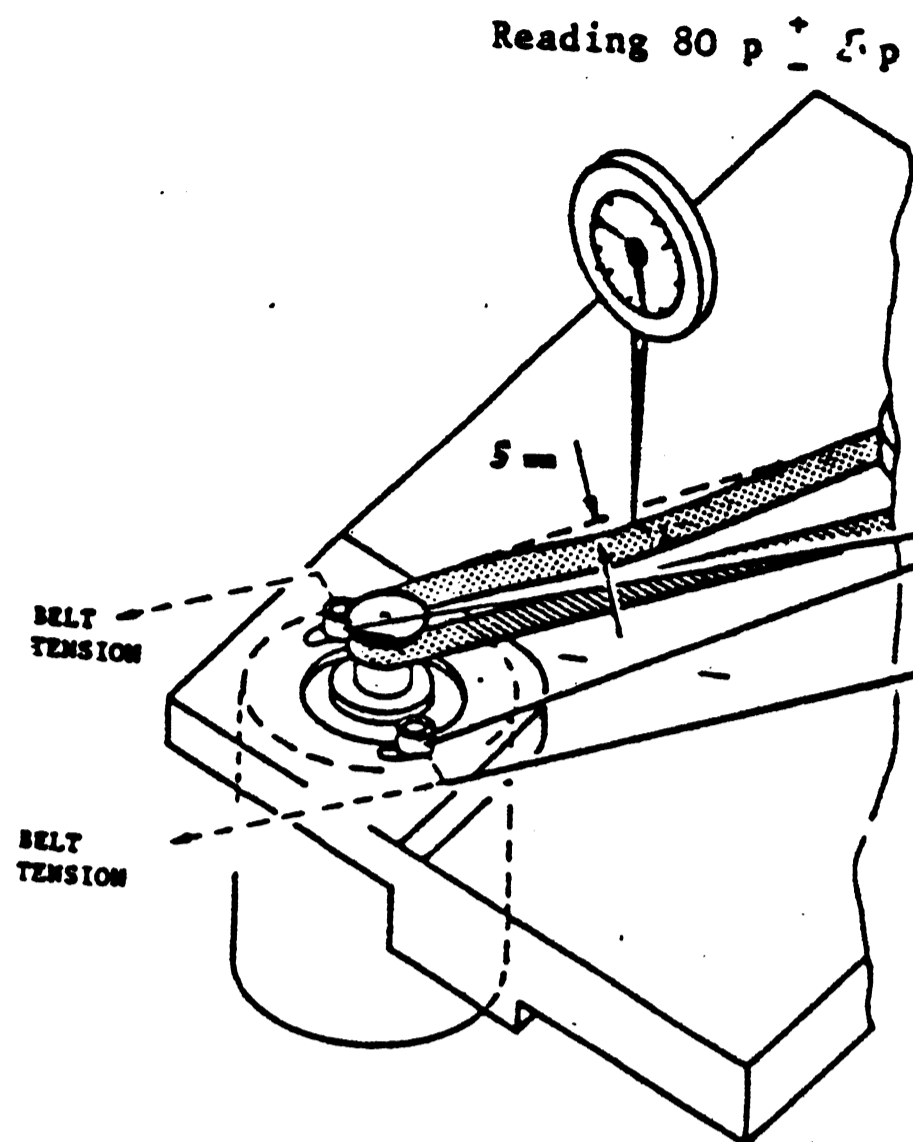

4.3.2.3 DRIVE BELT REPLACEMENT AND TENSION ADJUSTMENT

- a. Slightly loosen the drive motor screws.
- b. Adjust the drive belt tension for a reading of $80 p \pm 5 p$ on the dial gauge, when the drive belt is 5 mm deflected.
- c. Tighten the drive motor setscrews.

4.3.2.4 DRIVE MOTOR SPEED CHECK

- a) Load a BASF-CE-Mini Diskette.
- b) Turn on drive motor.
- c) Check that the dark lines of the tacho disk on the spindle pulley appear motionless. Use the inside ring for 50 Hz and the outside ring for 60 Hz. *)

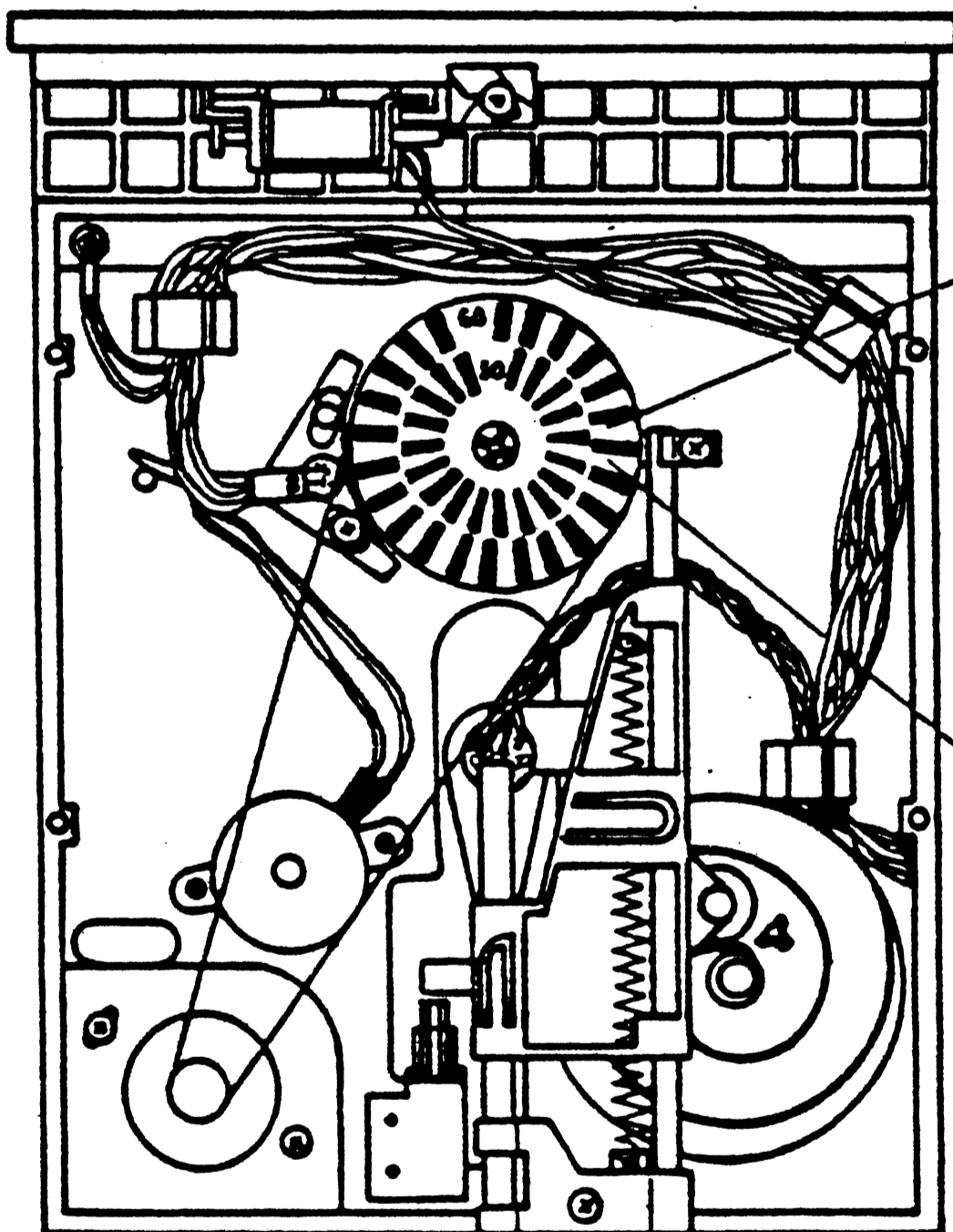

4.3.2.5 DRIVE MOTOR SPEED ADJUSTMENT

- a) Load a BASF-CE-Mini Diskette.
- b) Turn on drive motor.
- c) Position to track 16 and load head.
- d) Turn the potentiometer R 47 until the dark lines of the tacho disk on the spindle pulley appear motionless. Use the inside ring for 50 Hz and the outside ring for 60 Hz. *)

*) This adjustment is only possible in an area where fluorescent light exists. Otherwise, provide the adjustment or check as shown in 4.3.2.6.

4.3.2.6 DRIVE MOTOR SPEED ADJUSTMENT USING A FREQUENCY COUNTER

- a) Load a BASF CE-Mini Diskette.
- b) Connect a frequency counter to TJ2-8 (INDEX)
- c) Turn on the drive motor.
- d) Position to track 16 and load head.
- e) Measure time between two consecutive Index pulses and adjust pot R 47 to 200 msec \pm 1 msec if necessary.

4.3.2.7 DRIVE MOTOR REPLACEMENT

- a) Remove mini disk drive from mounting and place it on a clean work surface.
- b) Remove drive belt.
- c) Remove wire 2 and 4 of P6.
- d) Remove the two drive motor set screws. Drive motor is now removed from disk drive.
- e) Place new drive motor in same position and fasten it snugly. Tighten drive motor set screws.
- f) Reinstall wires 2 and 6 of P6.
- g) Install drive belt and verify correct tracking.
- h) Provide drive belt tension adjustment procedure (4.3.2.3).
- i) Perform speed adjustment.

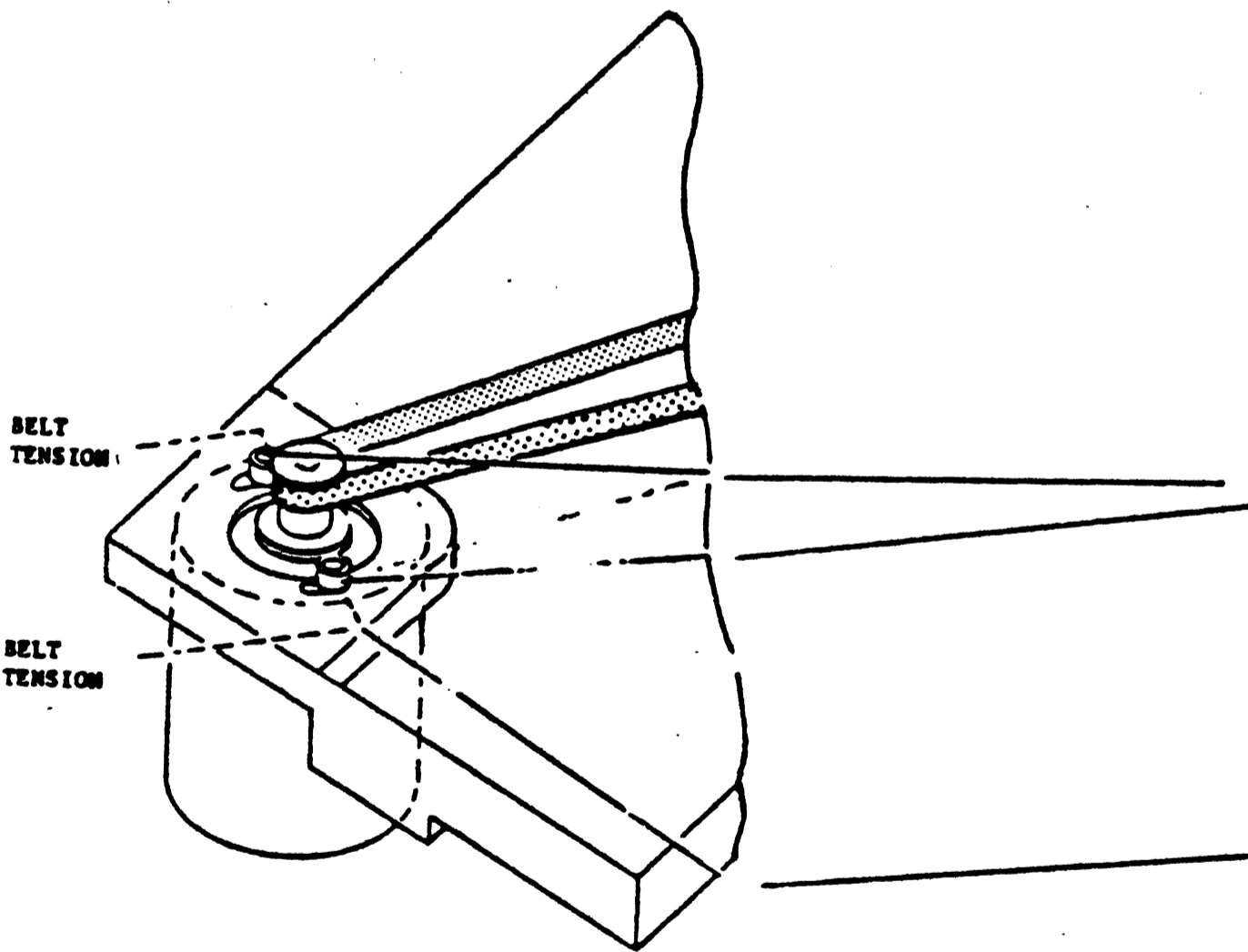

4.3.3 POSITIONING SYSTEM

The positioning system consists of the stepper motor with spiral wheel, the head carriage assembly and the optical track 00 switch.

4.3.3.1 TRACK ADJUSTMENT CHECK

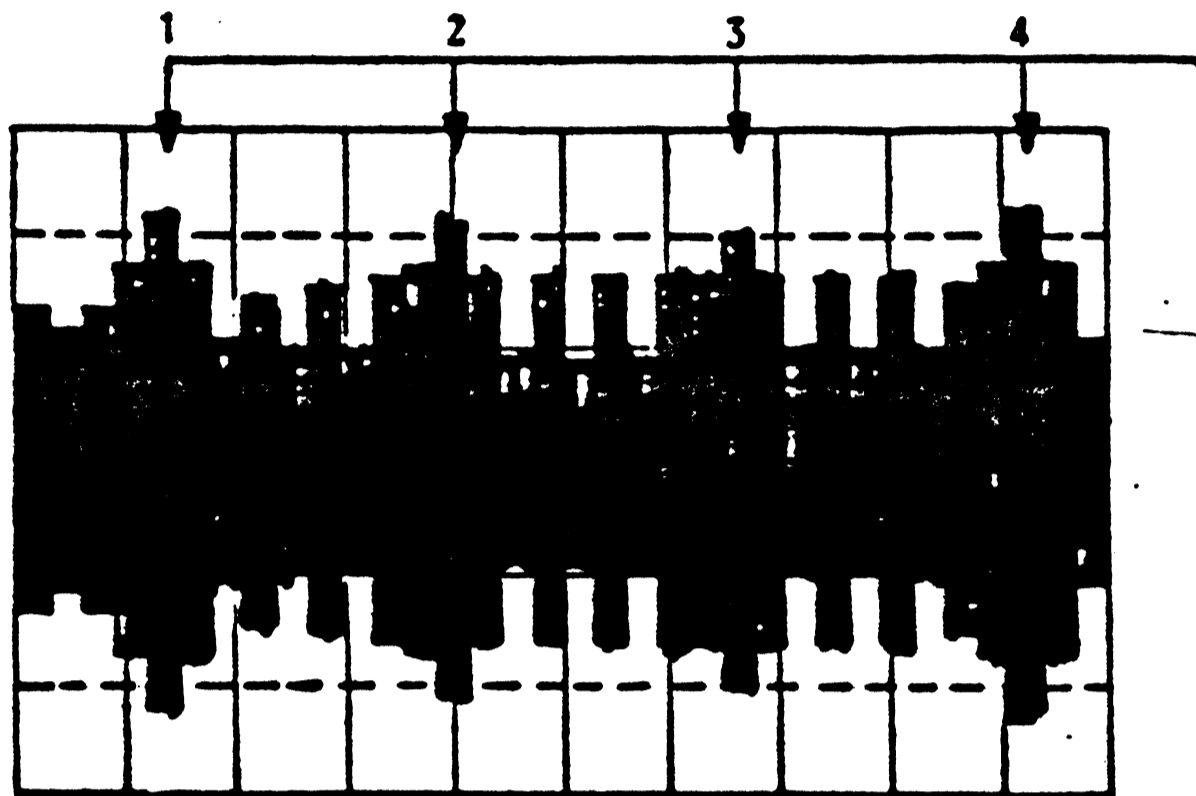

EXAMPLE:

$$X = U_1 - U_2 = + 2 \text{ scale units}$$

$$Y = U_3 - U_4 = - 4 \text{ scale units}$$

$$Z = X + Y = + 2 - 4 = - 2 \text{ scale units}$$

- a) Load a BASF-CE-Mini Diskette.
- b) Start the drive motor and select the mini disk drive.
- c) Select head 0.
- d) Step the carriage to track 16.
- e) Measure with oscilloscope:
 - SYNC : EXT. POS. TJ2-8 INDEX
 - CH 1 : AC 100 mV uncalibrated inverted TJ 1-7
 - CH 2 : AC 100 mV uncalibrated TJ1-9
 - MODE : ADD
 - TIME BASE: 10 ms/Div. uncalibrated
- f) Monitor the read signal on the screen and adjust the time base of the scope until four orientation bursts are shown.
- g) Turn the variable gain potentiometer of the scope until the amplitude of the orientation burst reaches 60 scale units.
- h) Determine X and Y (see example!)
 - $X = U_1 - U_2$ Caution: Pay attention to sign
 - $Y = U_3 - U_4$
- i) Calculate Z
 - $Z = X + Y$
- k) If Z exceeds 18 scale units proceed with point f of track adjustment procedure (4.3.3.2). Continue for BASF 6108. (1 DIV = 10 SCALE UNITS).
- l) Select Head 1
- m) Proceed through point f to i for head 1.
- n) If Z exceeds 18 scale unit proceed with point f of track adjustment procedure (4.3.3.2). If Z is lower than 21 scale units, the track adjustment is o.k.

4.3.3.2 TRACK ADJUSTMENT PROCEDURE

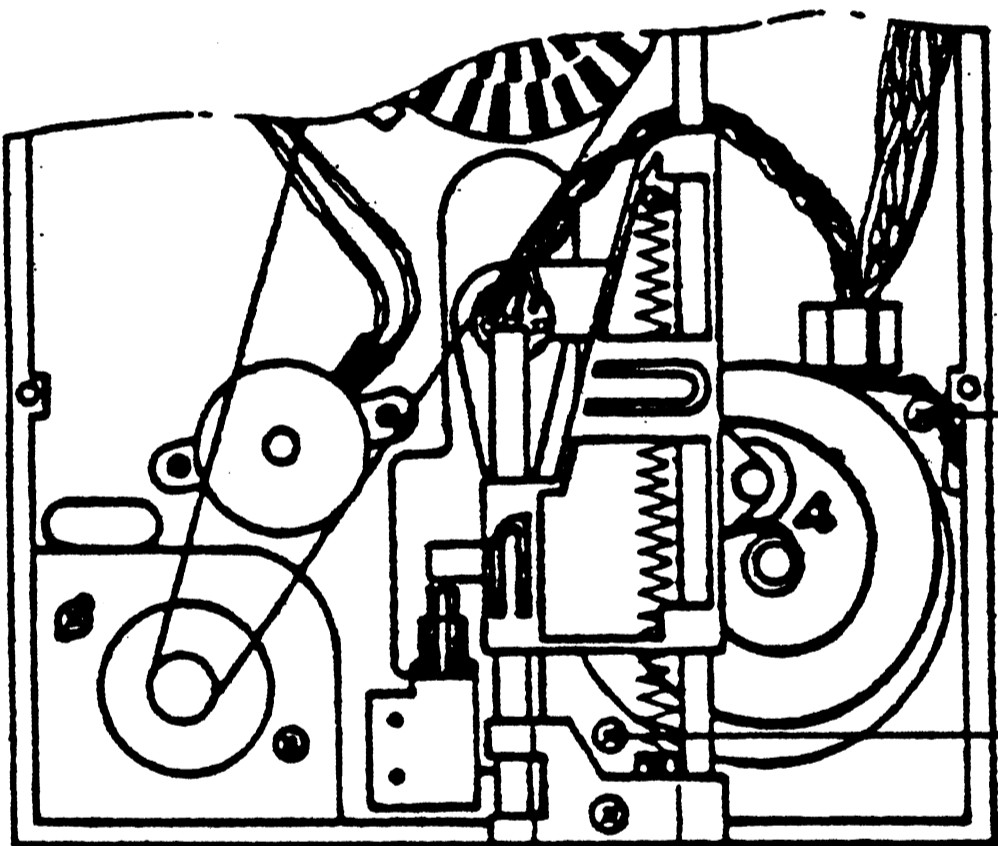
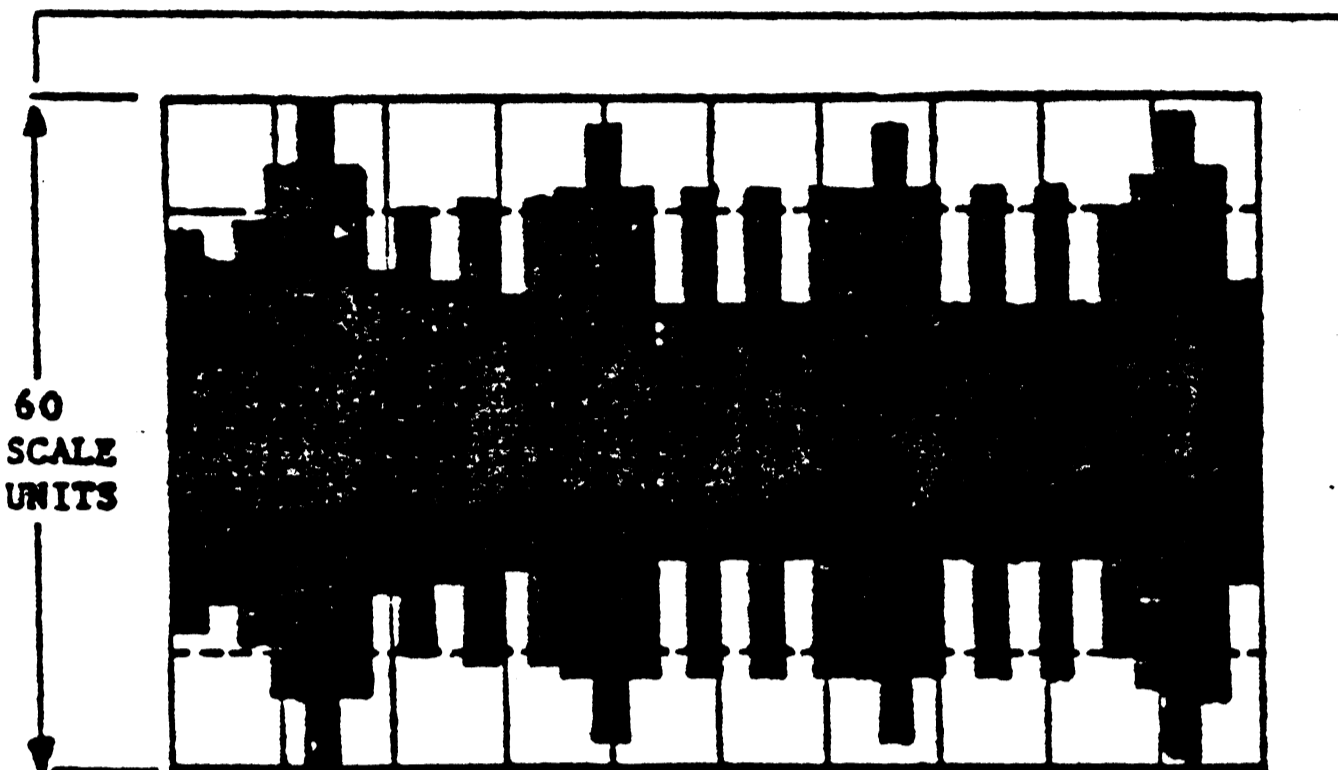
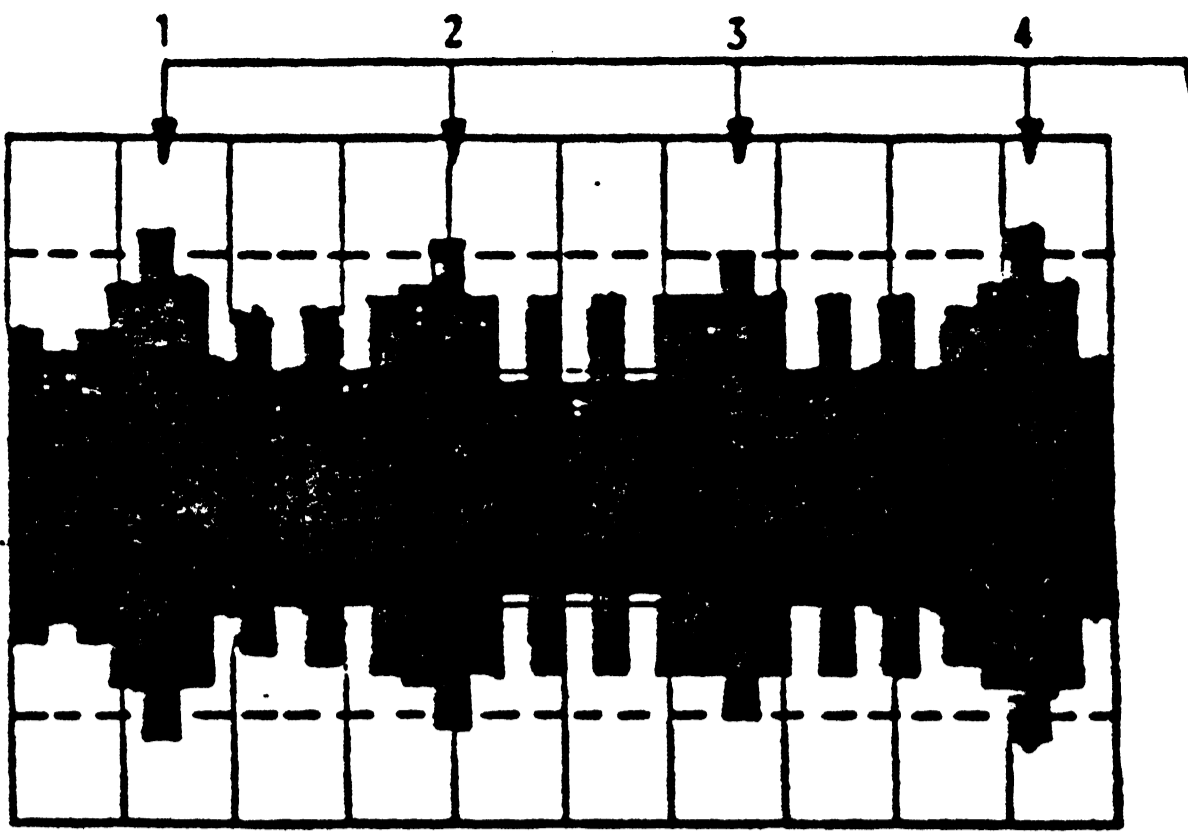

- a) Load a BASF CE-Mini Diskette.
 - b) Start the drive motor and select the mini disk drive.
 - c) Select Head 0.
 - d) Step the carriage to track 16.
 - e) Measure with oscilloscope:
 SYNC : EXT. POS. TJ2-8 INDEX
 CH1: AC 100 mV uncalibrated inverted TJ 1-7
 CH2: AC 100 mV uncalibrated TJ 1-9
 MODE: ADD
 TIME BASE: 10 msec/Div. uncalibrated
 - f) Loosen the mounting screws of the stepper motor and rotate body of the stepper motor until the maximum amplitude of the orientation bursts is reached.
 - g) Monitor the read signal on the screen and adjust the time base of the scope until four orientation bursts are shown.
 - h) Turn the variable gain potentiometer until the amplitudes of the orientation burst reaches 60 scale units.
 - i) Rotate the body of the stepper motor until X and Y have the same value but opposite sign, or both are zero.
 - j) Tighten the mounting screws of the stepper motor.
 - k) Recheck the adjustment. If X and Y exceed 4 scale units readjust the stepper motor (Pay attention to sign!).
 - l) For BASF 6106 perform track zero switch adjustment check.
- For BASF 6108:
- m) Select head 1 and begin with d) until f).
 - n) Provide points g) and h) for head 1.
 - o) Measure X + Y. It must be less than 4 scale units. Readjust, if necessary.
 - p) Check the adjustment from head 0, if X + Y is lower than 10 scale units.
 - q) Perform track zero switch adjustment check (4.3.3.3).

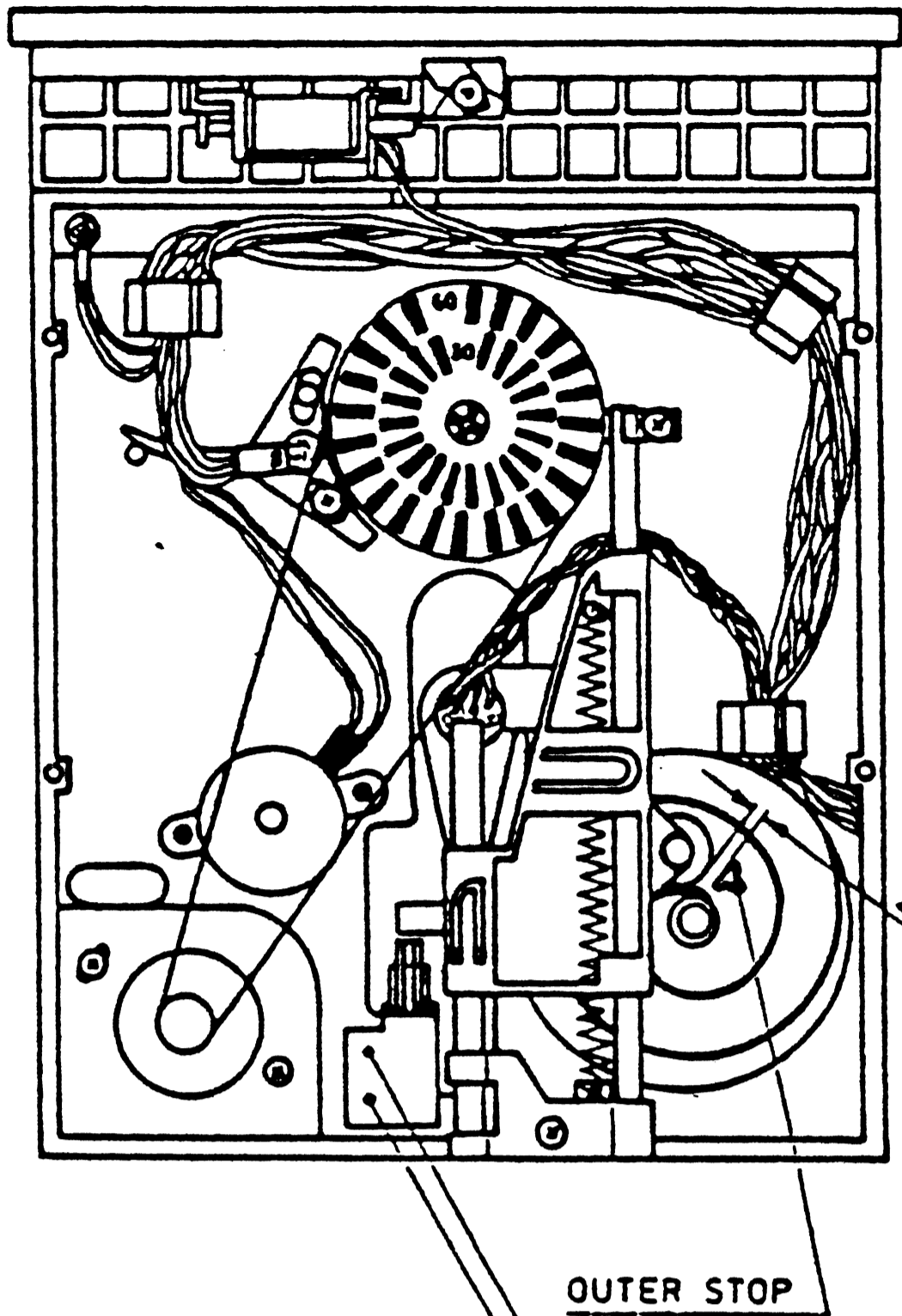

4.3.3.3 ADJUSTMENT CHECK FOR OPTICAL TRACK ZERO SWITCH

- a) Select mini disk drive and start drive motor.
- b) Monitor TJ2-3 (TRACK ZERO SWITCH).

SYNC : AUTO

CH 1 : 2 V/Div. TJ 2-3

MODE : CH 1 only

TIME BASE : 10 msec/Div.

- c) Step out to track 0.

- d) Check space between head carriage and outer stop for ~ 2.5 mm. If the space is not correct provide track zero switch adjustment.

- e) Check if track zero switch closes (TJ2-3 is low) between tracks 3 and 2 when stepping towards track zero and opens (TJ2-3 is high) between tracks 2 and 3 when stepping from track 0 to track 4. If the track zero switch will not change within these limits provide track zero switch adjustment.

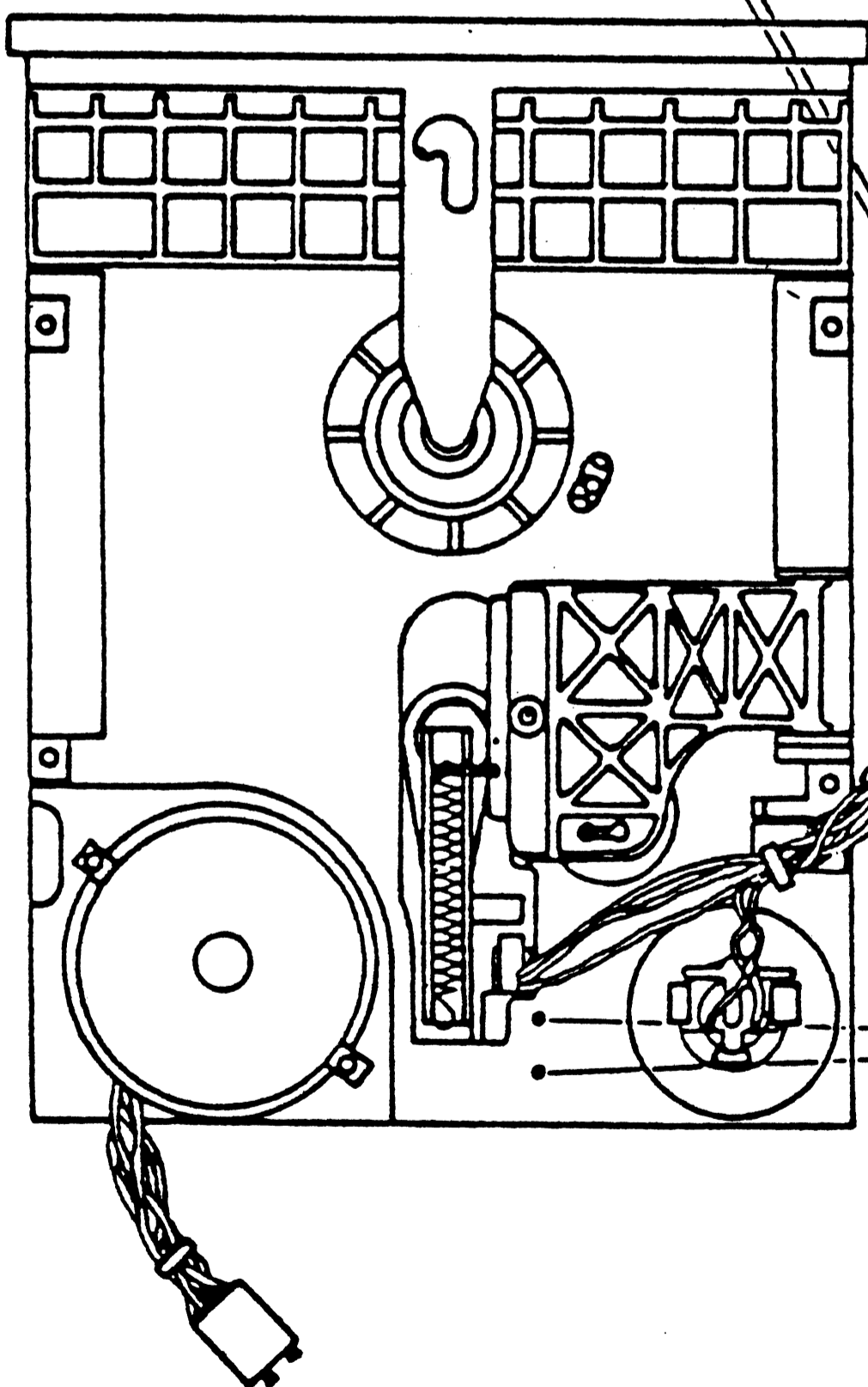

4.3.3.4 ADJUSTMENT FOR OPTICAL TRACK ZERO SWITCH

- a) Load BASF FLEXY DISK
- b) Select mini disk drive and start drive motor.
- c) Measure with oscilloscope.

SYNC : AUTO

CH 1 : 2 V/Div. TJ 2-6 (Track 00)

CH 2 : 2 V/Div. TJ 2-3 (Track 0-Switch)

MODE : Chopped

TIME BASE : 10 msec/Div.

- d) Step the head carriage out until the head carriage touches the outer stop.

- e) Step in until CH 1 goes high (normally one step in). Now the head carriage is positioned at track 0.

- f) Loosen the track 0 switch and adjust it that it will close (TJ 2-3: high → low) between tracks 3 and 2 when the head carriage is moved towards track 0 and will open (TJ 2-3: low → high) between tracks 2 and 3 when the head carriage is stepped from track 0 to track 4.

4.3.3.5 TRACK ZERO SWITCH REPLACEMENT

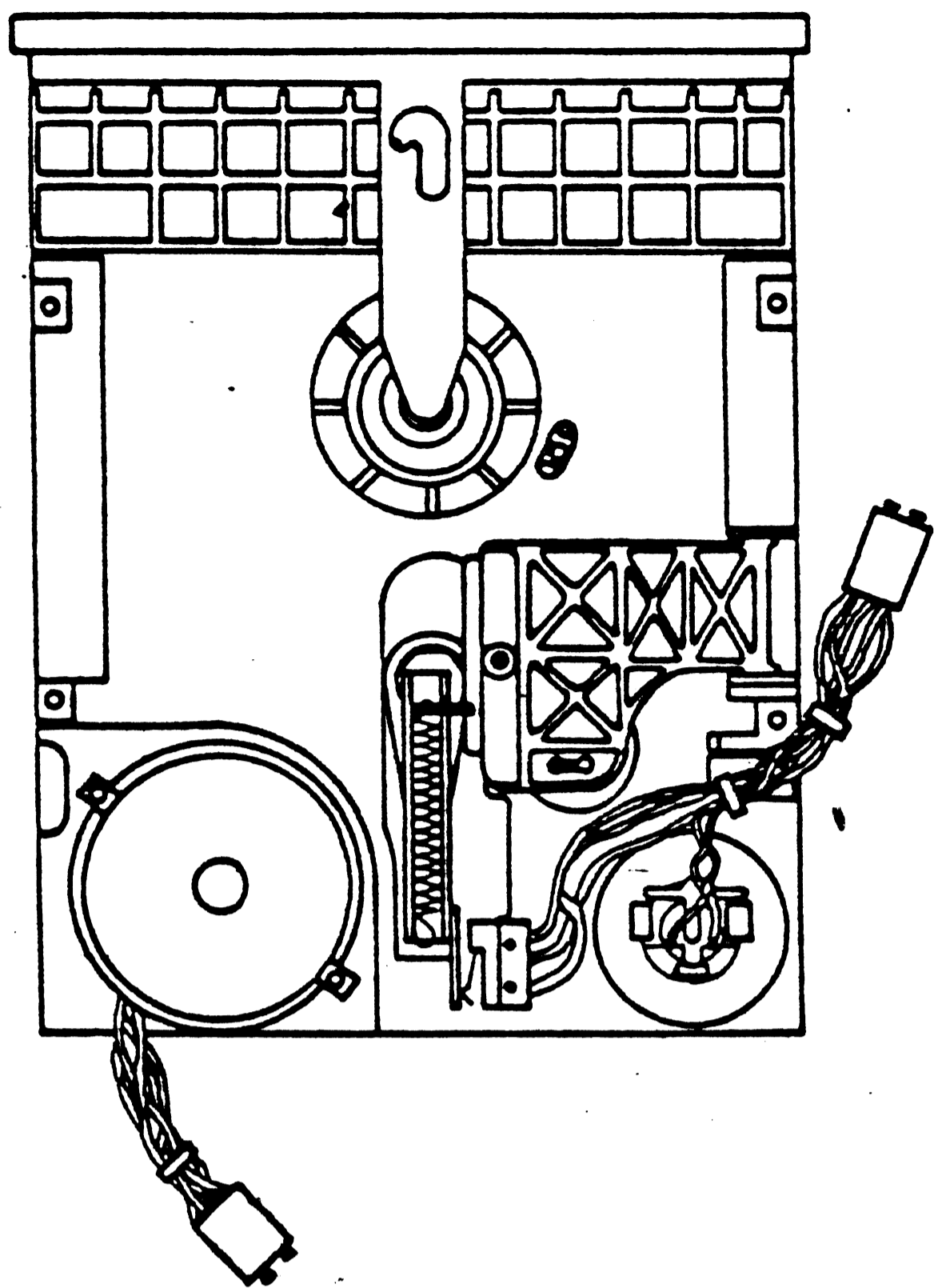

A) Mechanical Track Zero Switch

- a) Turn off all DC input power.
- b) Remove PCB.
- c) Remove holding screws of the track zero switch (on the rear).
- d) Remove the wires of the track zero switch.
- e) Connect the wires to the new track zero switch.
- f) Install the new track zero switch and the PCB.
- g) Provide the track zero switch adjustment.

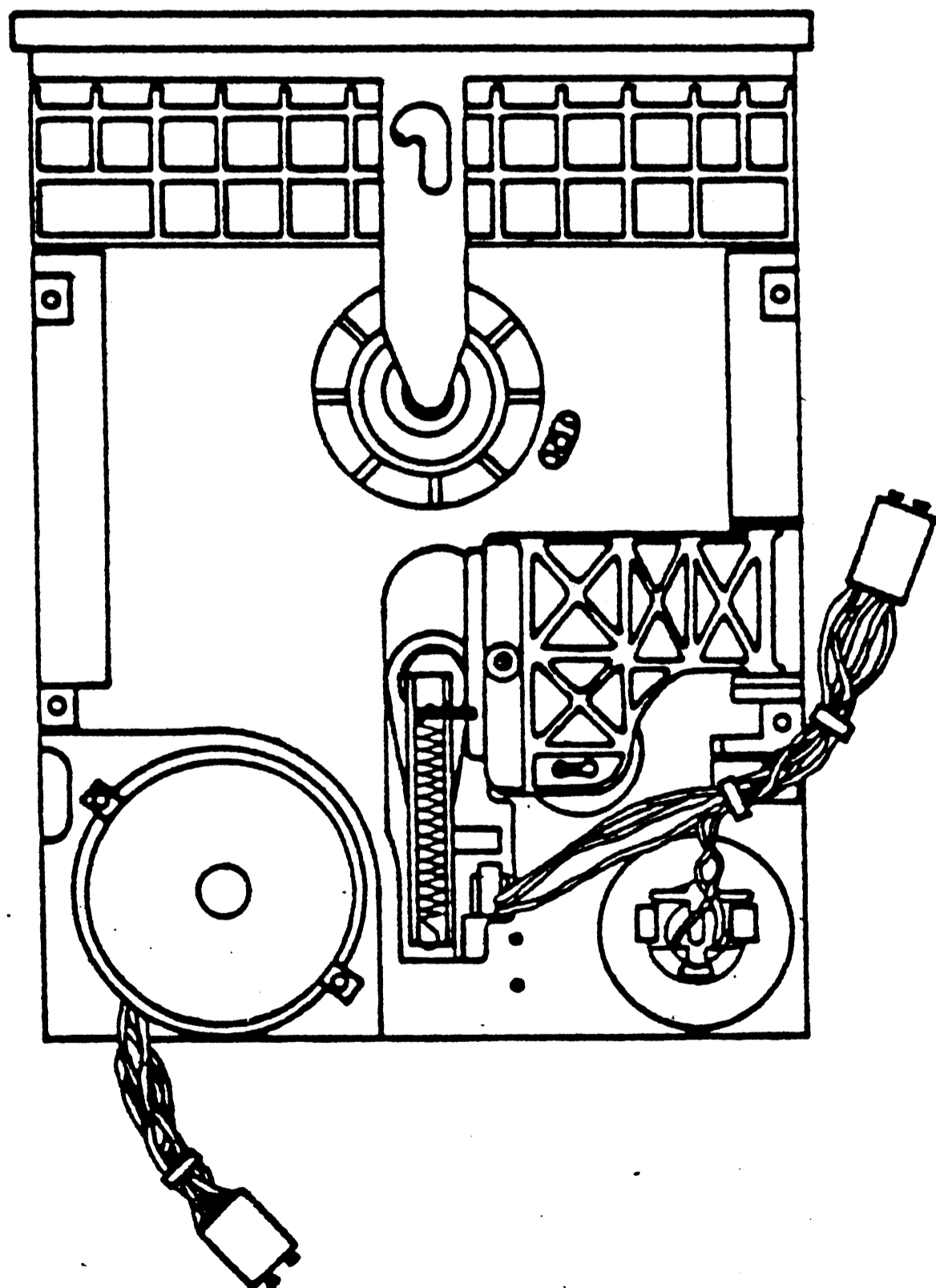

B) Optical Track Zero Switch

- a) Turn off all DC input power.
- b) Remove PCB.
- c) Remove holding screws of the track zero switch (on the rear)
- d) Remove the wires of the track zero switch.
- e) Connect the wires to the new track zero switch.
- f) Install the new track zero switch and the PCB.
- g) Provide the track zero switch adjustment.

4.3.3.6 HEAD CARRIAGE REPLACEMENT

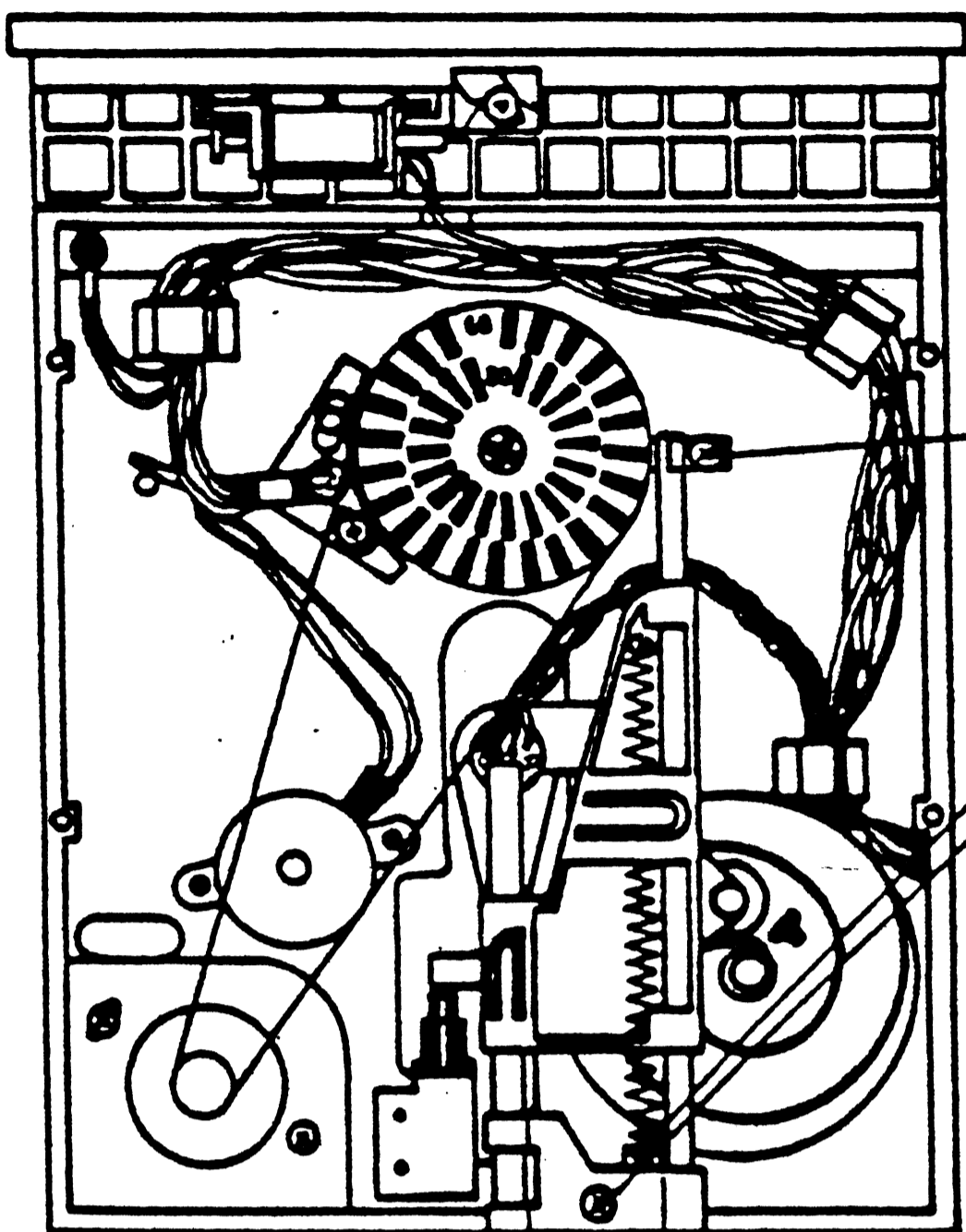

- a) Remove mini disk drive from mounting and place it on a clean working surface.
- b) Disconnect P 2.1 (2.2)
- c) Disengage the spring.
- d) Loosen the two holding screws and take out the carriage with the guide bars carefully.
- e) Pull out the guide bars from the R/W head carriage.

- f) To reinstall the new head carriage reverse the above procedure.

Caution: Handle spring carefully during reinstallation.

- g) Provide the track adjustment accordingly (4.3.3.2).

- h) Check the track zero switch adjustment (4.3.3.3).

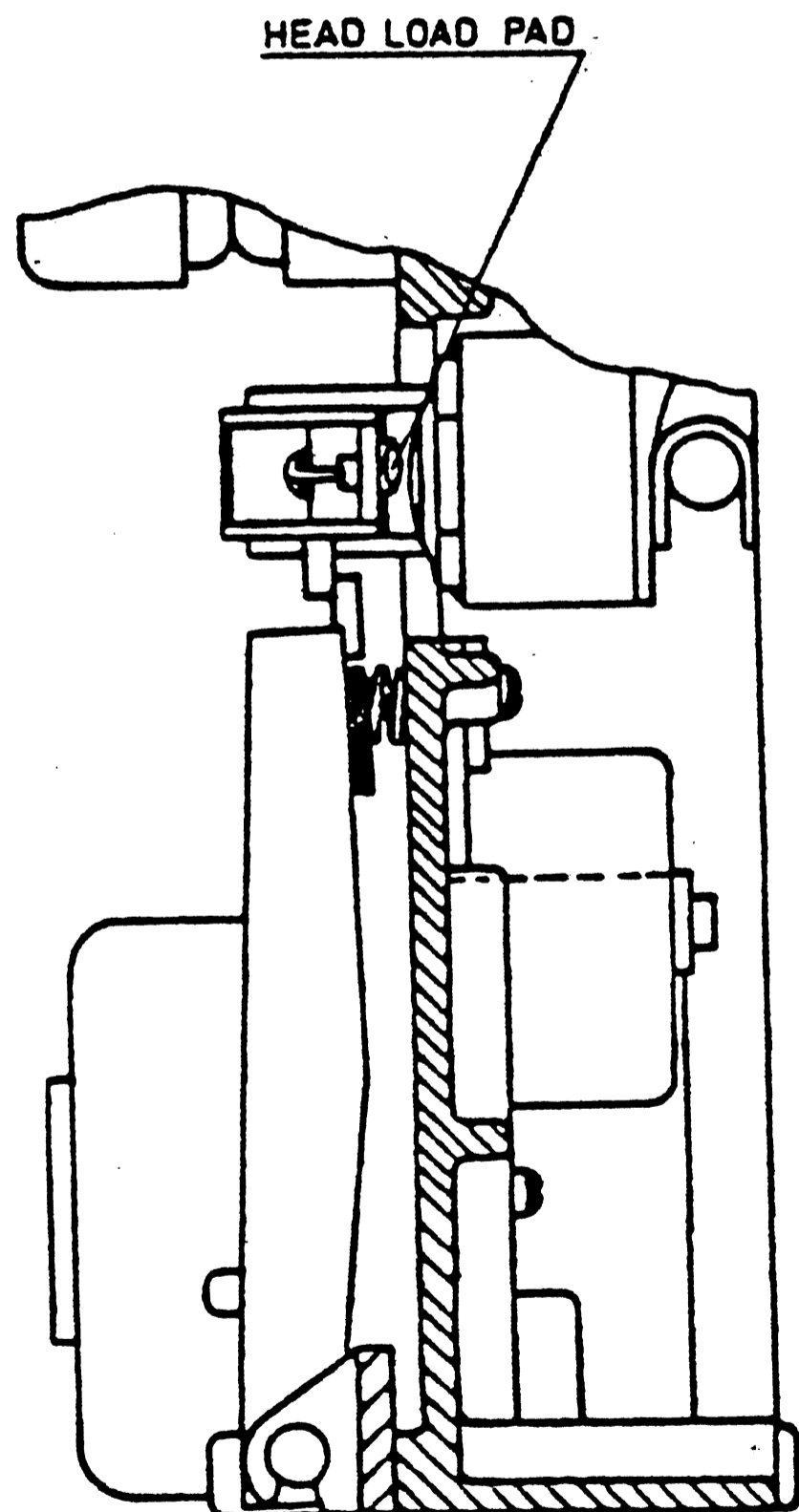

4.3.3.7 HEAD LOAD PAD REPLACEMENT (BASF 6106 only !)

- a) Remove the PCB (4.3.1).
- b) Remove the old head load pad.
- c) Install the new head load pad.
- d) Install the PCB.
- e) Check the jitter adjustment (4.3.5.1).
- f) Index Adjustment

4.3.4 HEAD LOAD MECHANISM

4.3.4.1 HEAD LOAD SOLENOID REPLACEMENT

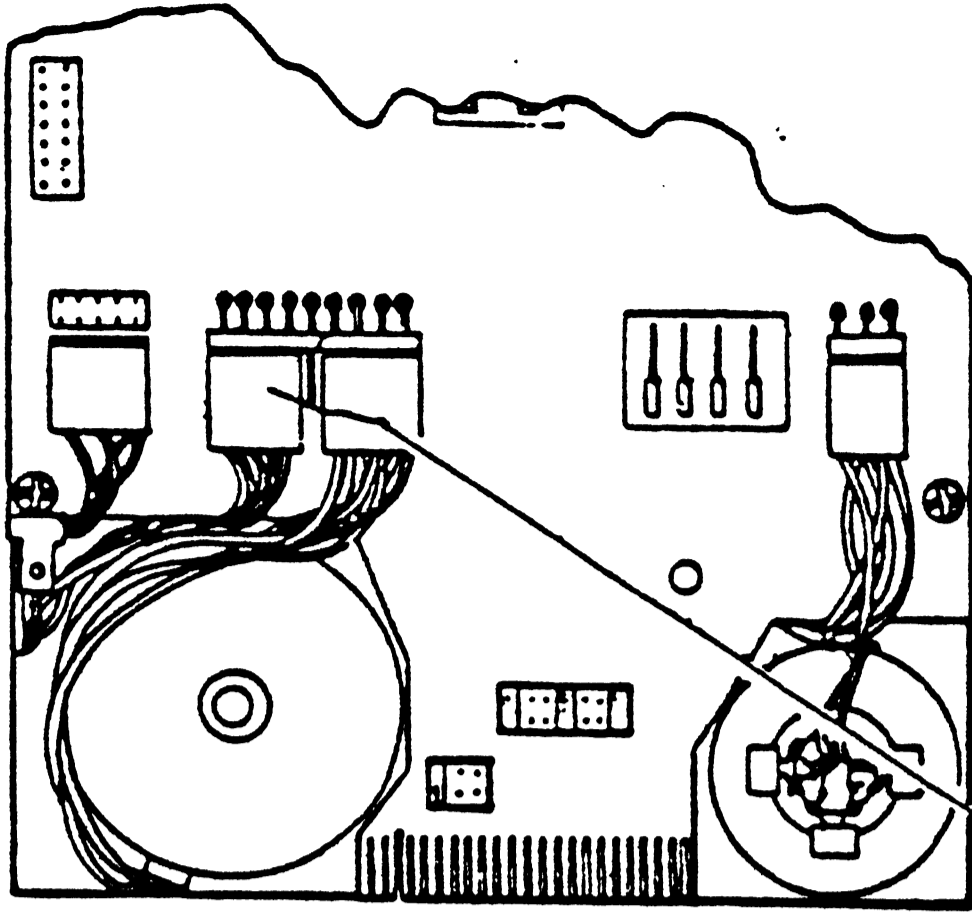

a) Remove mini disk drive from mounting and place it on a clean working surface.

b) Extract wires 1 and 3 from connector P 3.

c) Remove retainer ring and spacer shim.

d) Loosen the two holding screws and remove the head load solenoid.

e) To reinstall the head load solenoid reverse the above.

f) Check for proper airgap when solenoid is activated. Return to the factory in case of gap being too small. Adjustment in the field is not possible.

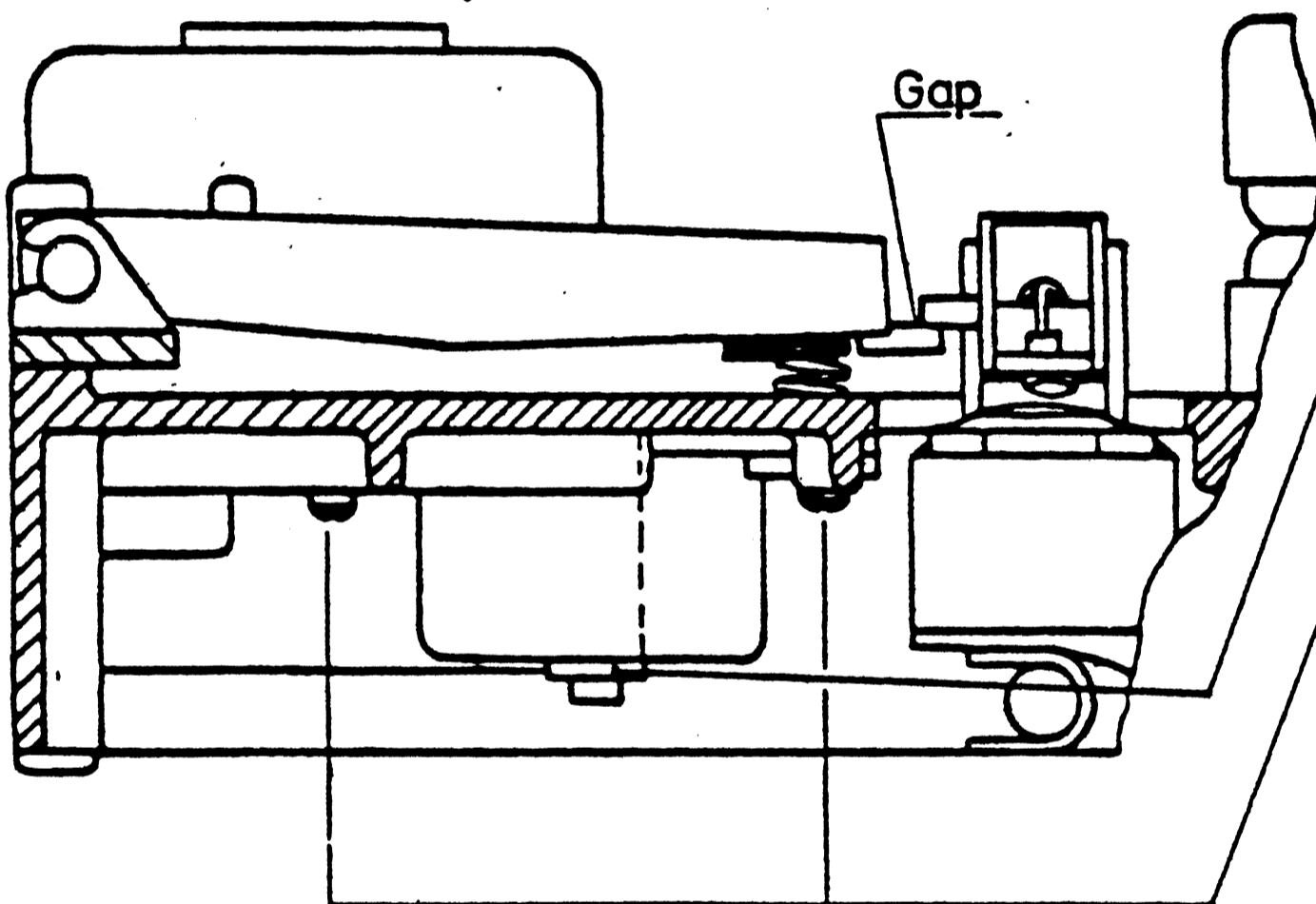

4.3.4.2 HEAD LOAD ACTUATOR CHECK

a) Load the head.

b) The clearance between the head load actuator and the pin on the head load pressure arm should be between 0.5 mm and 1 mm.

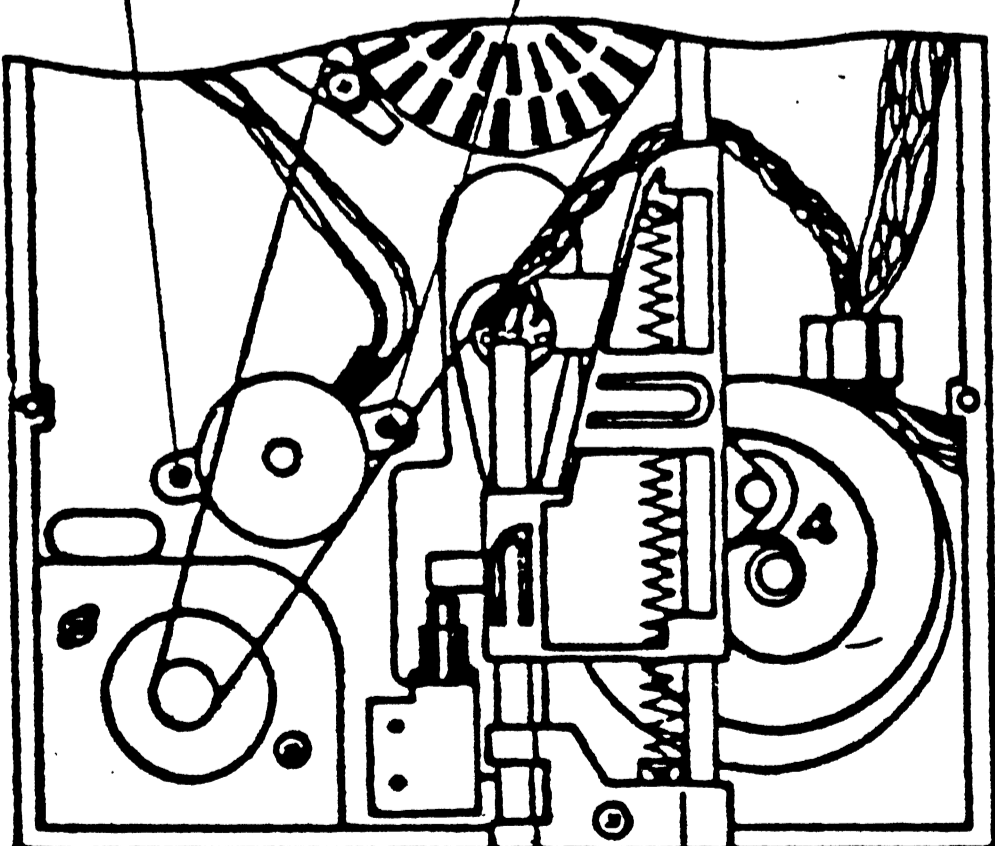

4.3.5 READ/WRITE ELECTRONICS

4.3.5.1 JITTER CHECK AND ADJUSTMENT

- Load a BASF Flexy Disk.
- Turn on drive motor.
- Step to track 39.
- Write all FM-ZEROS(1F) for BASF 6106(Head 0)
for BASF 6108 (Head 0 and 1)

e) Measure with oscilloscope:

SYNC: INT. POS. CH1
CH 1: DC 2V/Div. 10-9 READDATA
CH 2: AC 20mV/Div. TJ1-7
TRIGGER: Read Data uncalibrated

f) Trigger oscilloscope, that the read data signal "cateyes" are displayed.

g) Measure jitter. If jitter of head 0 or Head 1 (track 39, 1F) is ≥ 500 ns adjust pot R69.

- for minimum jitter at BASF 6106
- for best compromise between jitter of head 0 and head 1 for BASF 6108

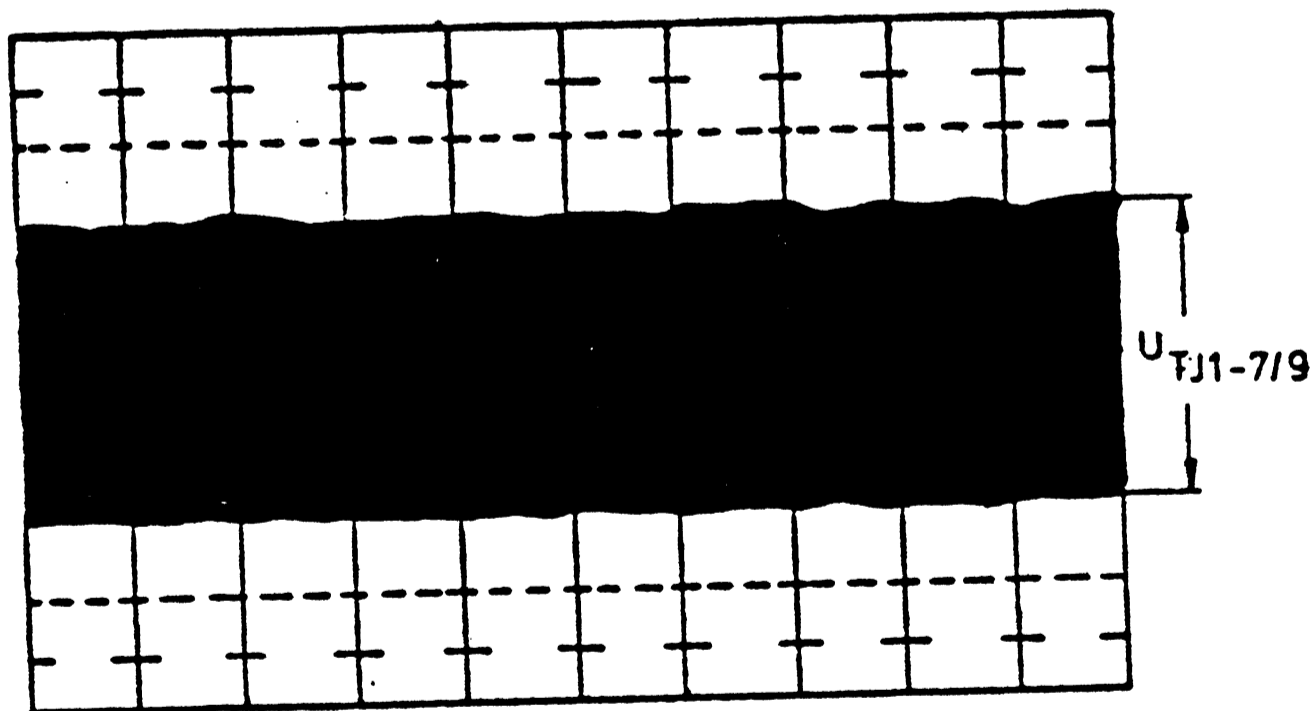
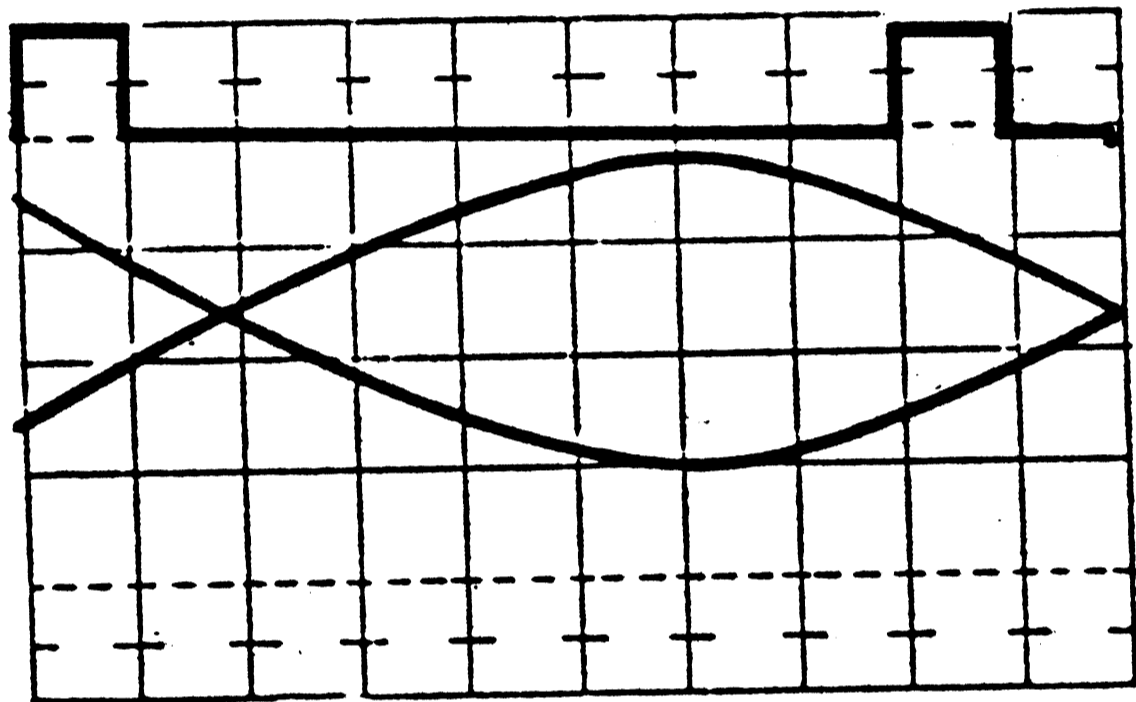
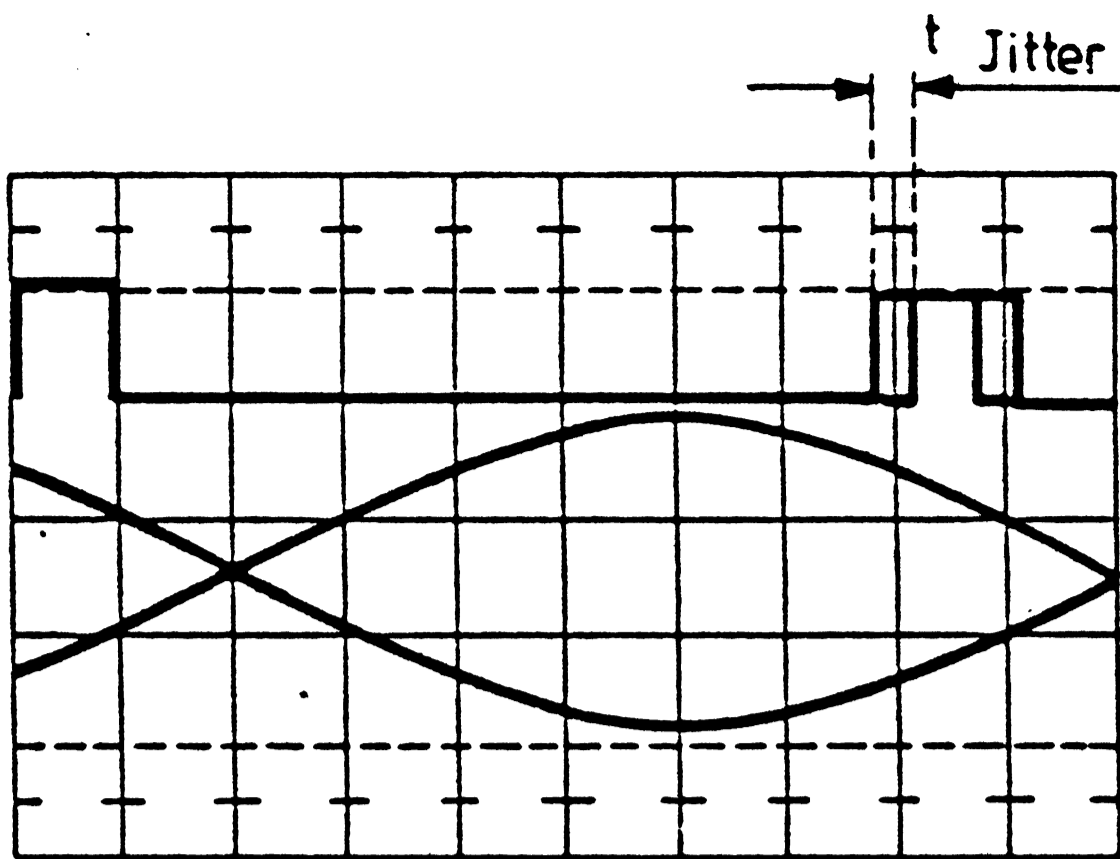

Note 1. Values mentioned above relate to electronic board P.No. 88366-001 only. For P.No. 88366-002 the following limits apply for differential read voltage at TJ1-7/9:

Head 0 : $U_{TJ1-7/9} \geq 0,07$ Vpp

Head 1 : $U_{TJ1-7/9} \geq 0,07$ Vpp

4.3.5.2 READ AMPLITUDE CHECK

- Load a BASF Flexy Disk.
- Turn on drive motor.
- Step to track 39.
- Select Head 0.
- Write all "ones".

f) Measure with oscilloscope:

SYNC: EXT. POS. TJ 2-8 INDEX
CH 1: AC 50 mV/Div. inverted TJ1-7
CH 2: AC 50 mV/Div. TJ1-9
MODE: ADD
TIME BASE: 20 msec/Div.

g) Check the measured read voltage at TJ1-7/9 for the following limits:

$$U_{TJ1-7/9} \geq 0,4 \text{ Vpp (see note 1)}$$

Continue for BASF 6108!

h) Select head 1.

i) Write all "ones".

k) Check the measured read voltage at TJ1-7/9 for the following limits:

Head 0

$$U_{TJ1-7/9} \geq 0,4 \text{ Vpp}$$

Head 1

$$U_{TJ1-7/9} \geq 0,4 \text{ Vpp}$$

see note 1

4.3.6 PHOTO TRANSISTORS AND LED's

4.3.6.1 PHOTO TRANSISTOR REPLACEMENT

- a) Disconnect plug of defective photo transistor.
- b) Remove photo transistor.
- c) Insert new photo transistor.
- d) Reconnect plug.
- e) Check the function of the photo transistor.
- f) Provide the index detector adjustment, if the index photo transistor has been changed.

4.3.6.2 LED-REPLACEMENT

- a) Remove the LED from PCB board.
- b) Put in the new LED.
- c) Check the function of the LED.
- d) Provide the index detector adjustment.

4.3.6.3 INDEX DETECTOR ADJUSTMENT CHECK

The tracks 00 are prewritten with 1f containing an index alignment gap at the beginning of track.

The index sensor is aligned properly when the beginning of the gap is time-coincident with the leading edge of index pulse (see Fig. to the left).

- a) Load a BASF-CE mini disk.
- b) Select head 0.
- c) Start the drive motor and select the mini disk drive.
- d) Step to track 0.
- e) Measure with oscilloscope:
SYNC:EXT. POS. TJ2-8
CH 1:DC 2V inverted TJ2-8 (index)
CH 2:AC 100 mV TJ1-9 (read data)
TIME BASE: 100 μ sec/Div.
- f) Check the timing between start of the sweep and the data burst for 450 μ sec \pm 100 μ sec.
- g) Provide the index detector adjustment (4.3.6.4) if necessary.

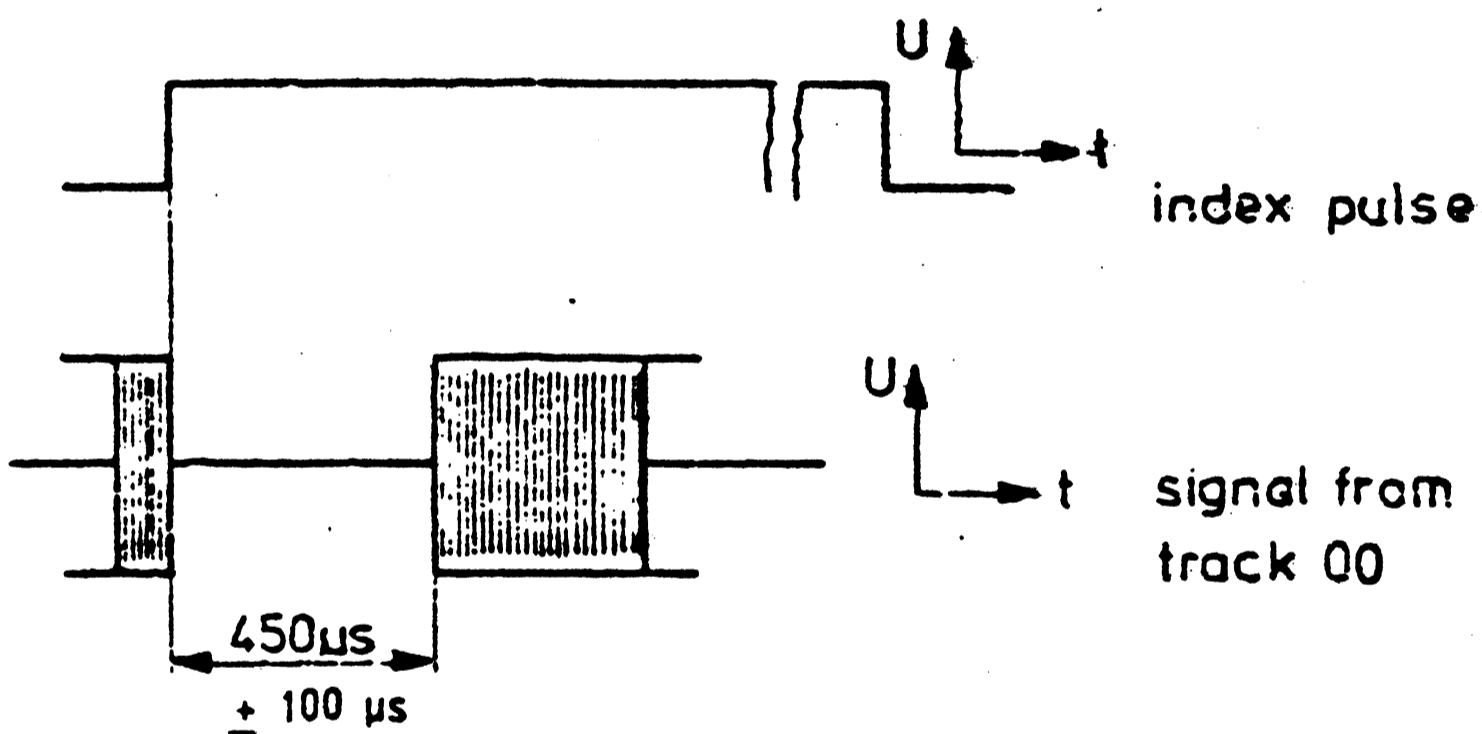

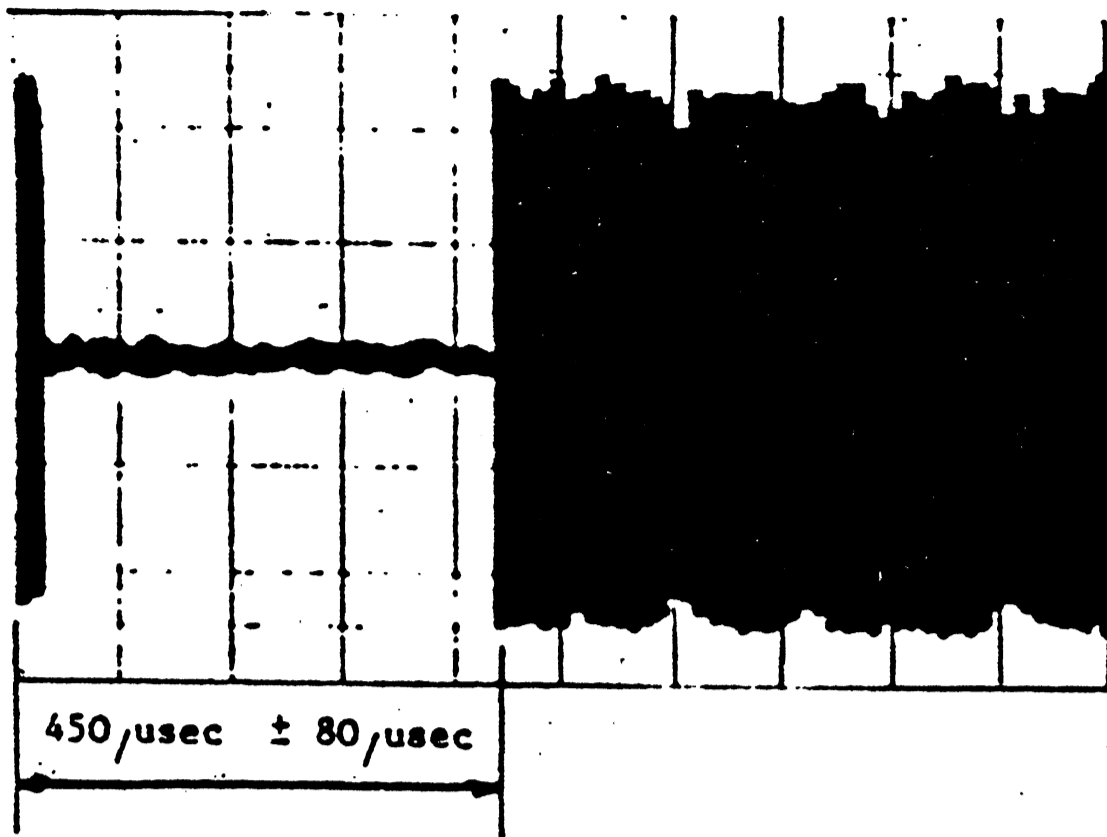

4.3.6.4 INDEX DETECTOR ADJUSTMENT

- a) Load a BASF-CE Flexy Disk
- b) Start the drive motor and select the mini disk drive.
- c) Step to track 0.
- d) Measure with oscilloscope:

SYNC: EXT. POS. TJ2-8 Index

CH 1: AC 100 mV inverted TJ1-7

CH 2: AC 100-mV TJ1-9

MODE: 100 ,usec/Div.

TIME BASE: 100 ,usec/Div.

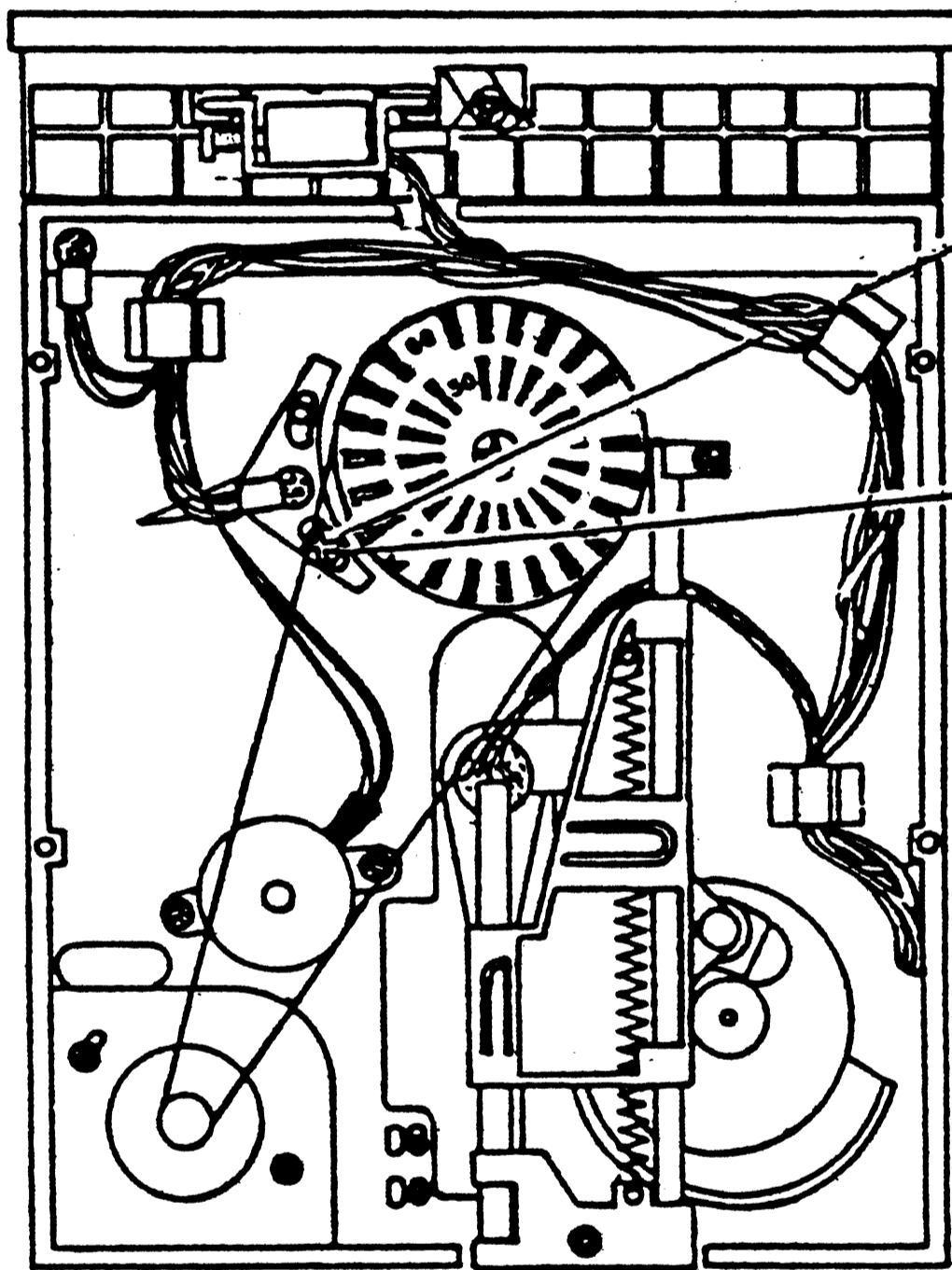

- e) Loosen the set screw of the index-holder.
- f) Adjust the time delay between start of the sweep and the data burst to 450 ,usec ± 80 ,usec.
- g) Tighten the index holder set screw.

4.4 LOCATION OF TESTPOINTS, IC's
POTENTIOMETERS AND CONNECTORS

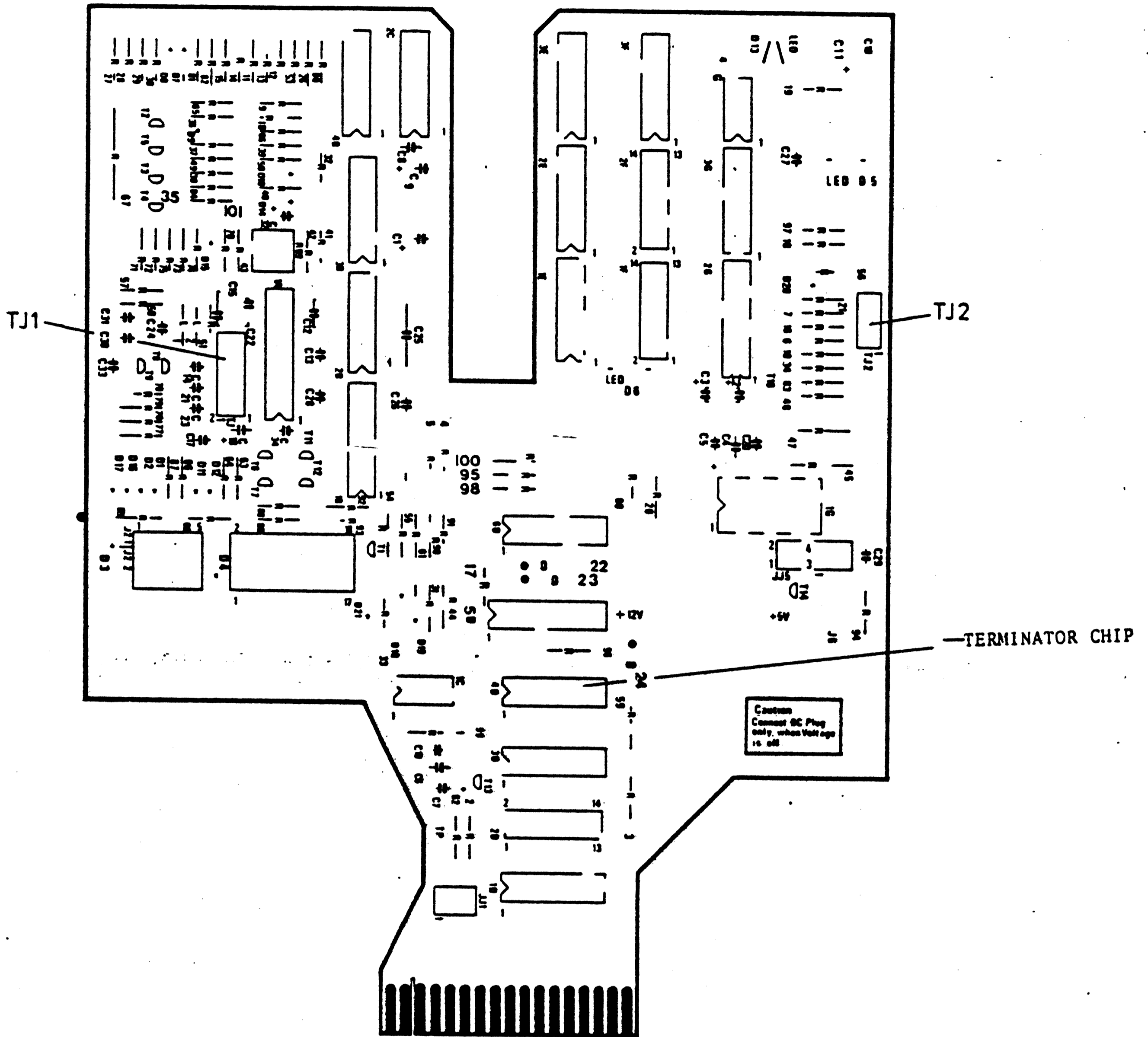

POTI	FUNCTION
R 47	Drive Motor Adjust
R 69	Jitter Adjust

Connector	Function	
J1	Signal - Interface	
J2	Read/Write - Head (s)	
J3	1,3	Head Load Solenoid
	2,4	Door Lock Solenoid
	5,6	Write Protect Phototransistor
	7,8	Index Phototransistor
	11-18	Stepper Motor
J5	DC- Connector	
J6	2,4	Drive Motor
	3,5,6	Track Zero Switch

Test Points	Signal	
TJ1	1,2	Write Current Signal
	3,5	Read Signal (Preamp. Output)
	6	GND
	7,9	Read Signal (Differentiator Input)
	8	Jitter Voltage
	10	Erase Current T.P.
TJ2	11,12	Write Current T.P.
	1	DISK CHANGE FF/
	2	PWRONRESIT/
	3	TRACK ZERO SWITCH
	4	IN USE- FF
	5	MOTOR ON
	6	TRACK OO
	7	GND
8	INDEX	

ANLAGE 1 ZUM TECHNICAL MANUAL
ATTACHMENT 1 TO THE TECHNICAL MANUAL

ERSATZTEILE KATALOG
SPAREPARTS CATALOG

MODEL 6106 MINI DISK DRIVE

IN DIESEM ERSATZTEILE-KATALOG SIND NUR DIEJENIGEN TEILE
UND BAUGRUPPEN-NRN. AUFGEListET, DIE BEI DER BASF-AG ALS
ERSATZTEILE VERFÜGBAR SIND.

IN THE PRESENT SPARE PARTS CATALOG YOU WILL FIND ONLY
PARTS AND ASSY-NOS. WHICH WILL BE AVAILBLE AS SPARE PARTS
FROM BASF-AG.



BASF Aktiengesellschaft
VERKAUF -M Datentechnik
68 Mannheim
Gottlieb-Daimler Str.10
Tel:0621/4008-380 Telex:462621

Copyright c 1980
by BASF Aktiengesellschaft

Rev.02

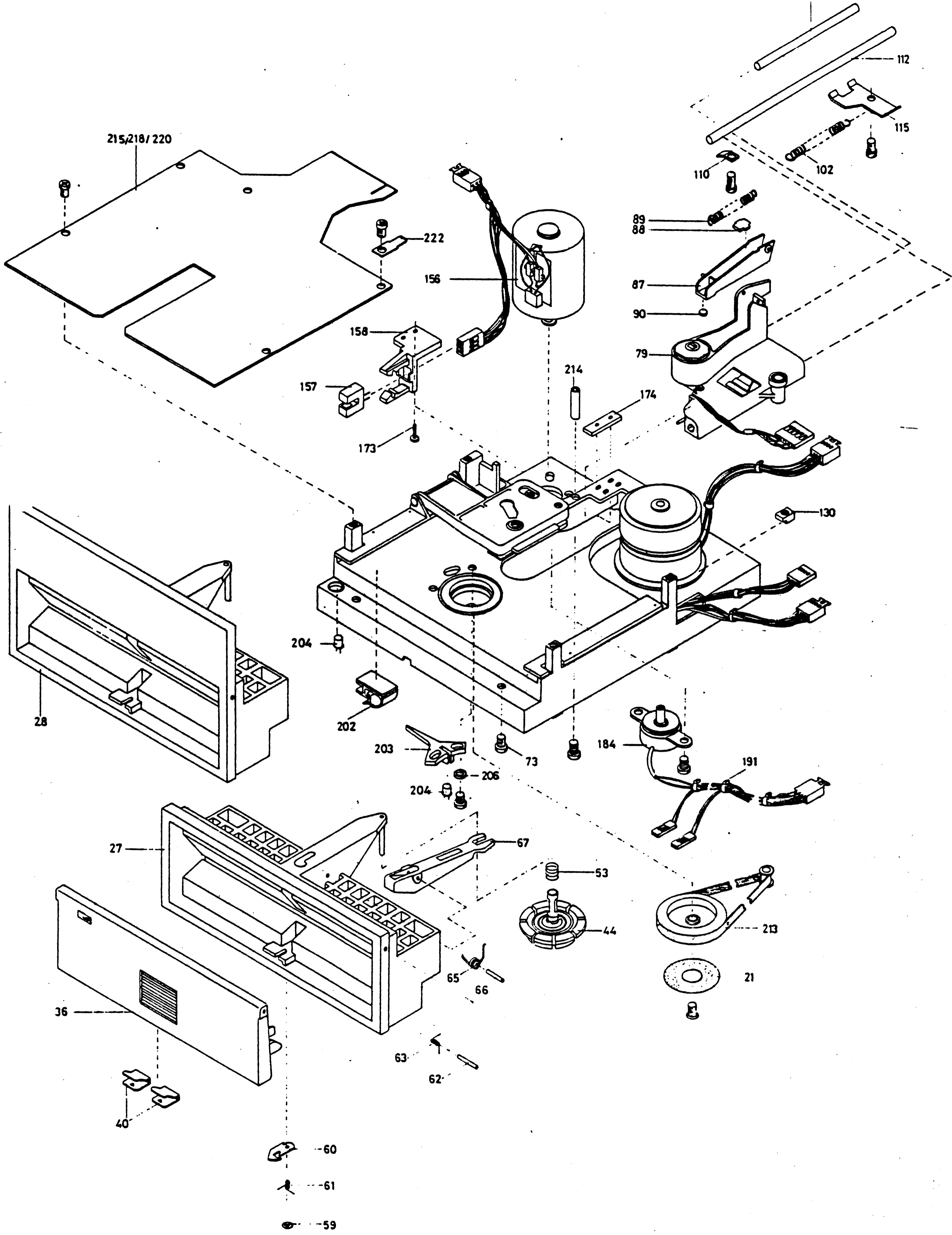

PARTS BEAKDOWN
MOD. 6106

ITEM	PART No.	DESCRIPTION	QTY PER ASSY NO:88 101-xxx					
			x01	x03	x07			
21	88 421-001	LABEL,TACHOSCOPE	1	1	1			
27	88 126-001	ASSY,FRONT CABINETT	1	1	-			
28	88 126-002	ASSY,FRONT CABINETT SHUGART	-	-	1			
36	88 131-001	ASSY,FRONT DOOR	1	1	1			
40	88 233-001	SPRING FOR DISK TRACKING	2	2	2			
44	88 129-002	ASSY,CONE THRUST	1	1	1			
53	88 404-002	SPRING,COMPRESSION Ø 8	1	1	1			
59	88 316-020	BENZING-QUICKLOCK 2	1	1	1			
60	88 228-003	LATCH	1	1	1			
61	88 412-003	SPRING,TORSION	1	1	1			
62	88 305-014	PIN,PIVOT Ø 2x15,8	2	2	2			
63	88 407-001	SPRING,TORSION	2	2	2			
65	88 406-002	SPRING,TORSION	1	1	1			
66	88 305-029	PIN,PIVOT	1	1	1			
67	88 177-002	LEVER ARM-CONE THRUST	1	1	1			
73	80 958-014	CROSS,RECESSED,SCREW M3x6 5,8						
79	88 158-002	ASSY,CARRIAGE	1	1	1			
87	88 208-002	ARM,HEAD LOAD,MACHINED	1	1	1			
88	88 211-001	CLIP,DISTANCE	1	1	1			
89	88 400-001	SPRING,EXTENSION	1	1	1			
90	88 413-001	PAD,PRESSURE	1	1	1			
102	88 036-001	SPRING,EXTENSION	1	1	1			
110	88 227-001	SPRING,CLAMPING	1	1	1			
112	88 408-001	BAR,GUIDE Ø 5x130	1	1	1			
113	88 409-001	BAR,GUIDE Ø 5x71	1	1	1			
115	88 226-001	SPRING,CLAMPING	1	1	1			
130	88 179-001	SHOE,CLAMPING	2	2	2			
154	88 153-Y02	ASSY,SPINDLE MOTOR WITH TRACK O-SWITCH	1	1	1			
155	88 351-001	TRACK O-SWITCH	1	1	1			
156	88 153-Y03	ASSY,SPINDLE MOTOR WITH LIGHT BARRIER	1	1	1			

ITEM	PART No.	DESCRIPTION	QTY PER ASSY NO:88 101- xxx					
			x01	x03	x07			
157	88 368-XXX	JOINT LIGHT BARRIER	1	1	1			
158	88 214-001	HOLDER FOR LIGHT BARRIER	1	1	1			
173	89 375-156	CROSS, RECESSED SCREW M 2x8 5,8	2	2	2			
174	88 229-001	NUT PLATE	1	1	1			
184	88 154-001	ASSY, HEAD LOAD SOLENOID	1	1	1			
191	355038-002	TY, WRAP						
202	355027-016	CLAMP, CABLE						
204	505000-001	PHOTO TRANSISTOR	2	2	2			
203	88 207-001	HOLDER TRANSISTOR INDEX	1	1	1			
206	88 025-032	WASHER, FLAT 3,2 ST	1	1	1			
213	88 416-003	BELT SPINDLE	1	1	1			
214	88 221-001	THREADED BOLT	1	1	1			
215	88 366-002	PCB, CONTROL	1	1	1			
218 *	88 366-001	PCB, CONTROL	1	1	1			
220 **	88 356-001	PCB, CONTROL (for Drives with mech. Trk. 0 switch only)	1	1	1			
222	90 473-Y13	FLAT CONNECTOR 4,8	1	1	1			
		<u>OPT I O N S</u>						
236	88 159-001	ASSY, SI-LATCHING MAGNET	-	1	-			
241	80 641-102	CONNECTOR KIT						
242	320015-002	FLAT CONNECTOR P1	1	1	1			
243	98 403-002	FLAT PIN BUSHING 4,8	1	1	1			
244	200218-001	CONTACT LINER	1	1	1			
245	88 360-001	LINING CASE 4 POL P5	1	1	1			
246	80 976-001	SHORT-OUT-CONNECTOR	4	4	4			
		* USE ONLY TO ORDER COMPONENTS (see page 10, 11, 12, 13). If assy needed, order 88 366-002						
		** Use only to order components. (see page 7 and 8).						

CROSS REFERENCE LIST FOR SPARE-PARTS MDD 6106

PART NUMBER	ITEM	PART NUMBER (cont.)	ITEM
80 641-102	241	88 409-001	113
80 958-014	73	88 412-003	61
80 976-001	246	88 413-001	90
		88 416-003	213
88 025-032	206	88 421-001	21
88 036-001	102		
88 126-001	27	89 375-156	173
88 126-002	28		
88 129-002	44	90 473-Y13	220
88 131-001	36		
88 153-Y02	154	98 403-002	243
88 153-Y03	156		
88 154-001	184	200218-001	244
88 158-002	79		
88 159-001	236	320015-002	242
88 177-002	67		
88 179-001	130	355027-016	202
88 207-001	203	355038-002	191
88 208-002	87		
88 211-001	88	505000-001	204
88 214-001	158		
88 221-001	214		
88 226-001	115		
88 227-001	110		
88 228-003	60		
88 229-001	174		
88 233-001	40		
88 305-014	62		
88 305-029	66		
88 316-020	59		
88 351-001	155		
88 356-001	220		
88 360-001	245		
88 366-001	218		
88 366-002	215		
88 368-XXX	157		
88 400-001	89		
88 404-002	53		
88 406-002	65		
88 407-001	63		
88 408-001	112		

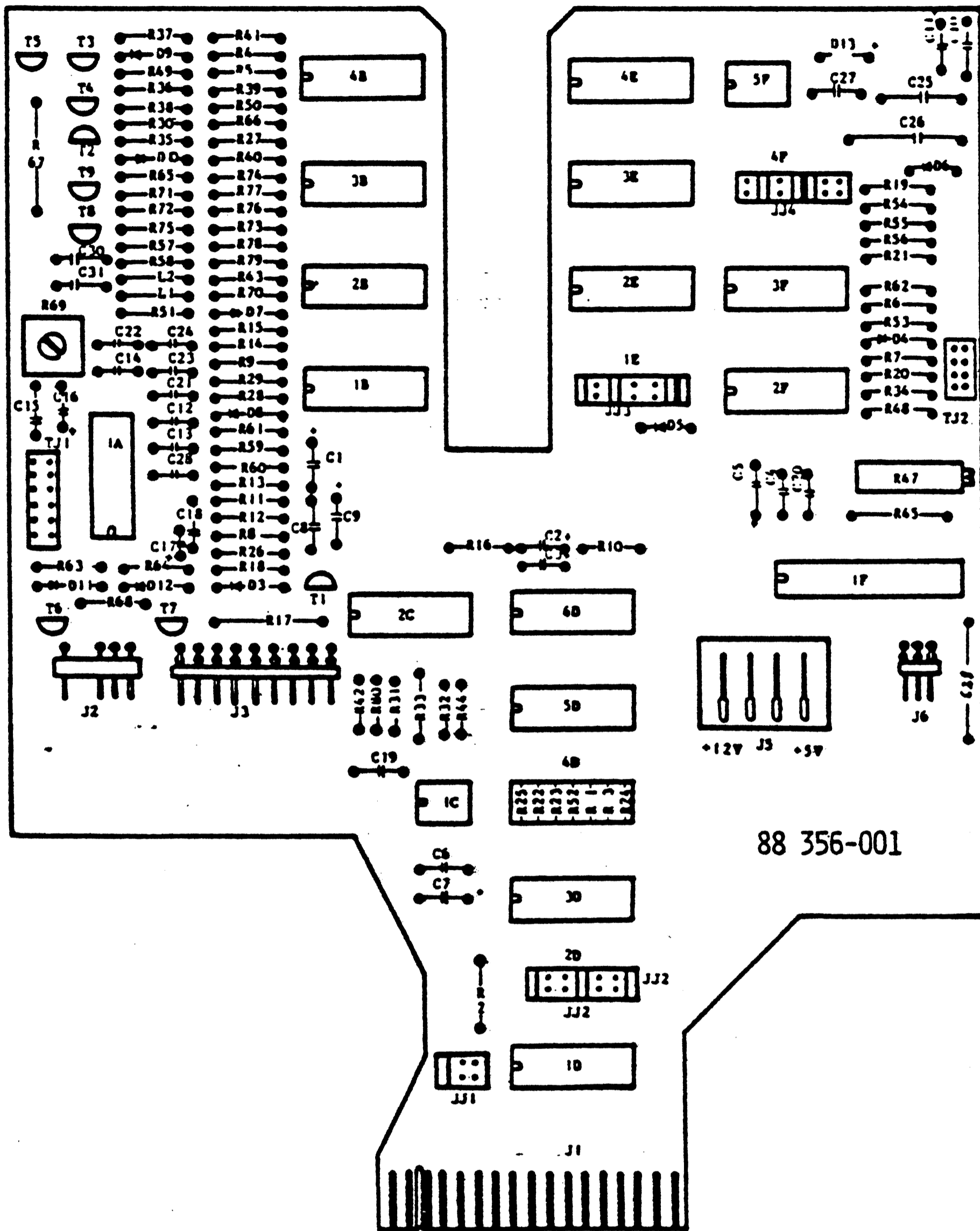

READ/WRITE CONTROL PCB COMPONENT
LOCATIONS

6106 88 356-001

REF. DESIGN.	PART NO.	DESCRIPTION	QTY PER ASSY NO: 88 356-XXX				
			001				
C1	80 934-053	CAPACITOR TANT. 33 μ F, 20V, 20%	1				
C2	80 934-041	CAPACITOR TANT. 22 μ F, 16V, 20%	1				
C3	80 934-076	CAPACITOR TANT. 2, 2 μ F, 35V, 20%	1				
C4, 6, 8, 10, 15, 18	305028-103	CAPACITOR 0, 01 μ F, 100V, 20%	6				
C5	80 934-054	CAPACITOR TANT. 47 μ F, 20V, 20%	1				
C7, 9, 11	80 934-031	CAPACITOR TANT. 47 μ F, 10V, 20%	3				
C12, 13, 32	98 175-133	CAPACITOR CER. 330pF, 200V, 10%	3				
C14	98 175-047	CAPACITOR CER. 47pF, 200V, 10%	1				
C16, 17	80 934-079	CAPACITOR TANT. 6, 8 μ F, 35V, 20%	2				
C19, 20, 21, 23, 30, 31	98 175-410	CAPACITOR CER. 0, 1 μ F, 50V, 10%	6				
C22	98 175-239	CAPACITOR CER. 3, 9 μ F, 100V, 10%	1				
C24	98 175-156	CAPACITOR CER. 560pF, 200V, 10%	1				
C25	88 353-153	CAPACITOR POLY. 0, 015 μ F, 200V, 5%	1				
C26	88 354-393	CAPACITOR POLY. 0, 039 μ F, 200V, 5%	1				
C27	98 175-210	CAPACITOR CER. 1000pF, 200V, 10%	1				
C28	10 781-422	CAPACITOR 0, 22 μ F, 50V, 10%	1				
C29	10 781-322	CAPACITOR! 0, 022 μ F, 100V, 10%	1				
D3 -D4	90 344-001	DIODE 1N4001	2				
D5, 6	81 079-001	L-DIODE LIT 60	2				
D7	17 202-043	DIODE ZENER ZPD 4, 3, 2%	1				
D8	90 346-082	DIODE ZENER 1N756(8, 2V)	1				
D9	90 346-068	DIODE ZENER 1N754(6, 8V)	1				
D10, 11, 12, 14, 15	90 342-001	DIODE 1N4154	5				
D13	80 975-001	L.-DIODE LD52C	1				
JJ 1	80 836-203	CONNECTOR 3P	1				
JJ 2, 3, 4	80 836-207	CONNECTOR 7P	3				
J2	80 946-101	CONNECTOR 4P	1				
J3	80 833-209	CONNECTOR 9P	1				
J5	88 359-001	CONNECTOR 4P	1				
J6	80 833-203	CONNECTOR 3P	1				
L1, 2	80 964-390	INDUCTOR IM2 - 390 μ H, 10%	2				
R1, 3, 22, 23, 24, 25, 52	10 412-115	RESISTOR, NETWORK 150 Ω , 1/4W, 2%	1				
R2, 9	90 364-151	RESISTOR 150 Ω , 1/4W, 5%	2				
R4, 31, 32, 59, 60, 63, 64	90 364-103	RESISTOR 10 K, 1/4W, 5%	8				
R34	90 364-153	RESISTOR 15 K, 1/4W, 5%	1				
R5	90 364-102	RESISTOR 1 K, 1/4W, 5%	13				
R 6, 7, 29, 30, 36, 39, 40, 50, 57, 58, 62, 71, 72	90 364-332	RESISTOR 3, 3K, 1/4W, 5%	4				
R8, 9, 53, 75	90 364-473	RESISTOR 47K, 1/4W, 5%	3				
R10, 26, 16	90 364-223	RESISTOR 22K, 1/4W, 5%	2				
R11, 13	90 364-104	RESISTOR 100K, 1/4W, 5%	2				
R12, 80	90 364-823	RESISTOR 82K, 1/4W, 5%	2				
R14, 15	90 366-409	RESISTOR 82 Ω , 1/4W, 5%	1				
R17							

READ/WRITE CONTROL PCB COMPONENTS

88 356-XXX

REF. DESIGN.	PART NO.	DESCRIPTION	QTY PER ASSY NO: 88 356-XXX			
			001			
R18,43,44	90 364-101	RESISTOR 100K,1/4W,5%	3			
R20,21	90 364-121	RESISTOR 120Ω,1/4W,5%	2			
R27,66	90 364-122	RESISTOR 1,2K,1/4W,5%	2			
R28,41,48,51,65	90 364-222	RESISTOR 2,2K,1/4W,5%	5			
R33	89 282-628	RESISTOR 390Ω,1/2W,1%	1			
R35	89 284-216	RESISTOR 1,78K,1/4W,5%	1			
R37,49	90 364-271	RESISTOR 270Ω,1/4W,5%	2			
R38	90 364-471	RESISTOR 470Ω,1/4W,5%	1			
R42	90 364-822	RESISTOR 8,2K,1/4W,5%	1			
R45	80 925-002	RESISTOR 0,9Ω,2W,5%	1			
R47	80 250-257	POTENTIOMETER 2K	1			
R54	89 284-340	RESISTOR 34,8K,1/4W,1%	1			
R55	89 284-341	RESISTOR 35,7K,1/4W,1%	1			
R56	90 364-221	RESISTOR 220K,1/4W,5%	1			
R61	90 364-393	RESISTOR 39K,1/4W,5%	1			
R67	90 366-158	RESISTOR 150Ω,2W,5%	1			
R68	90 364-472	RESISTOR 4,7K,1/4W,5%	1			
R69	95 413-325	POTENTIOMETER 25K	1			
R70	90 364-123	RESISTOR 12K,1/4W,5%	1			
R73,74	89 284-172	RESISTOR 619Ω,1/4W,1%	2			
R76,77	89 284-345	RESISTOR 39,2K,1/4W,1%	2			
R78,79	89 284-313	RESISTOR 18,2K,1/4W,1%	2			
T1	80 939-001	TRANSISTOR NPNBC338-16	1			
T2	80 935-001	TRANSISTOR PNPBC327/40	1			
T3,4,5,8,9	90 327-001	TRANSISTOR PNP 2N3906	5			
T6,7	505004-001	TRANSISTOR FET 2N5460	2			
TJ1	80 836-206	CONNECTOR 6P	1			
TJ2	80 836-204	CONNECTOR 4P	1			
1A	80 955-001	IC 3470	1			
1B	12 282-001	IC LM 339	1			
2B,3B,2F	92 136-001	IC SN 7474	3			
	97 607-001	IC SN 7407	1			
1C,5F	385014-001	IC SN 75453	2			
2C,2D	13 602-001	IC SN 7438	2			
5D	80 937-001	IC SAA 1027	1			
6D	94 526-001	IC 9602	1			
2E	19 296-001	IC SN 7402	1			
3E,3D	92 127-001	IC SN 7404	2			
4E	14 588-001	IC SN 74221	1			
1F	80 938-001	IC ESM 227N	1			
3F	18 773-001	IC SN 7432	1			
4D	97 272-001	IC-SOCKET 14P	1			
	355031-Y02	TESTPOINT GND(SCOPE)	1			
	80 976-001	PLUG SHORT CIRCUIT	11			

READ/WRITE CONTROL PCB COMPONENTS(CONT).

88 356-XXX

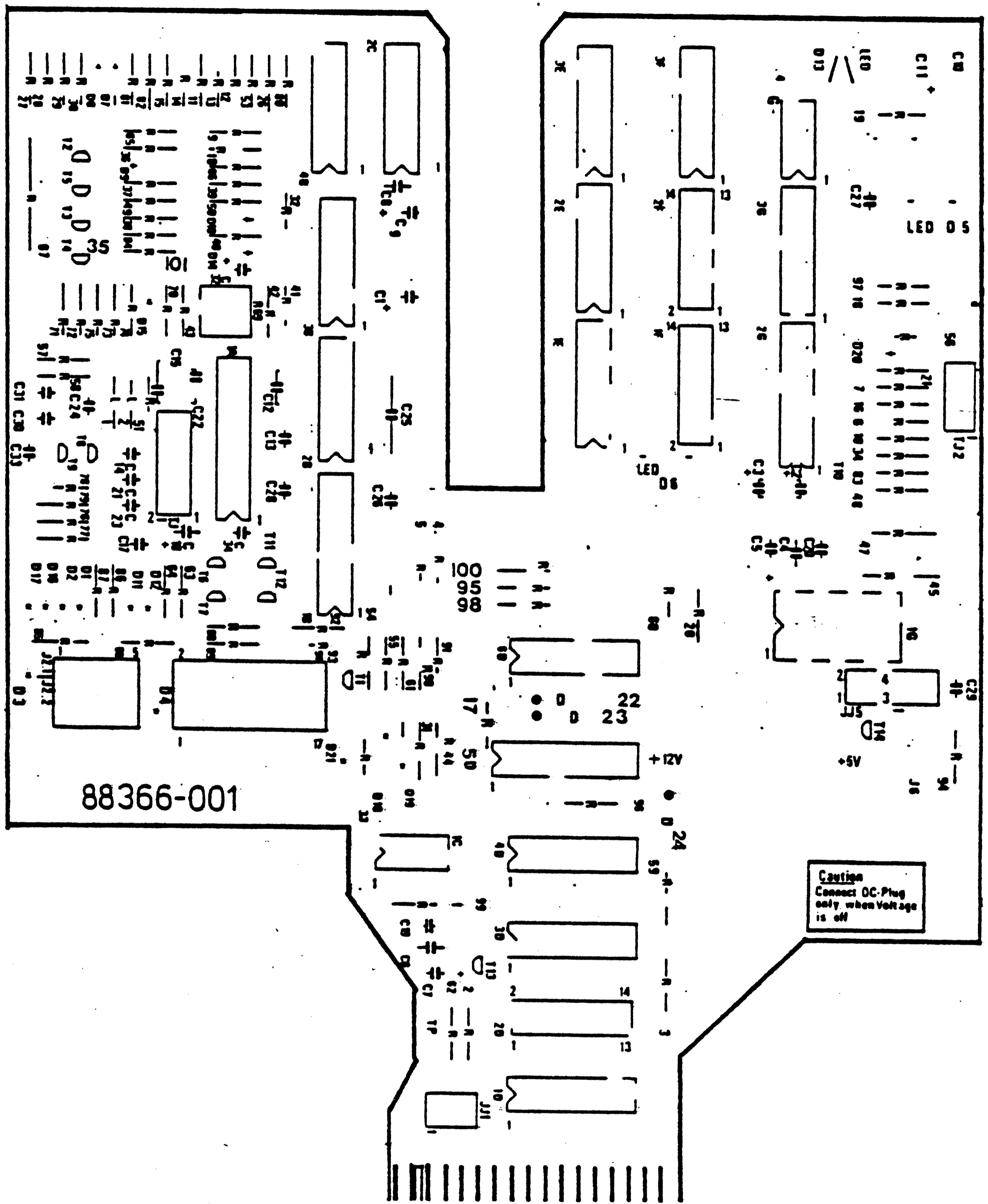

READ/WRITE CONTROL PCB COMPONENT

LOCATIONS

6106 88 366-001

<u>LFD</u> <u>NR.</u>	<u>TEILE NUMMER</u> <u>PART NUMBER</u>	<u>BENENNUNG</u> <u>DESCRIPTION</u>	<u>REFERENCE</u>	<u>QTY PER ASSY NO:</u> <u>88 366-001</u>
1				
2				
3				
4	19 296-001	IC SN 7402	3F	1
5	92 127-001	IC SN 7404	1E.3D.2C	1
6	97 607-001	IC SN 7407	3B	1
7	18 773-001	IC SN 7432	2E	1
8	13 602-001	IC SN 7438	1D.6D	2
9	92 136-001	IC SN 7474	2B.3E.3G	3
10	14 588-001	IC SN 74221	1B	1
11	385014-001	IC SN 75453	4G.1C	2
12	94 526-001	IC 9602	2G	1
13	12 282-001	IC LM 339	4B	1
14	80 955-001	IC 3470	1A	1
15	80 937-001	IC. SAA 1027	5D	1
16	80 938-001	IC ESM 227M	1G	1
17				
18	90 346-051	DIODE 1N751A(5.1V)	D22.D24	2
19	10 357-001	DIODE 1N4444	D1.2.10.11.12.14.15.16-19	11
20	90 344-001	DIODE 1N4001	D3.D4.D21	3
21	330705-001	L.DIODE ME 60	D5.D6	2
22	80 975-001	L.DIODE LD 52C	D13	1
23	17 202-043	ZENER DIODE ZPD 4.3.2%	D7	1
24	90 346-082	ZENER DIODE 1N756A(8.2V)	D8.D20	2
25	90 346-068	ZENER DIODE 1N754A(6.8V)	D9	1
26	90 346-036	ZENER DIODE 1N747A(3.6V)	D23	1
27	80 933-001	TRANSISTOR BC 338-16	T14	1
28	80 935-001	TRANSISTOR BC 328-40	T1.T2.T13	3
29	90 327-001	TRANSISTOR 2N3906	T3.4.5.8.9.10	6
30	81 082-001	TRANSISTOR FET J174	T6.T7	2
31	90 326-001	TRANSISTOR 2N3904	T11.T12	2
32				
33				

READ / WRITE CONTROL PCB COMPONENTS

88 366 - 001

LFD NR.	TEILE NUMMER PART NUMBER	BENENNUNG DESCRIPTION	REFERENCE	QTY PER ASSY NO: 88 366-001
34	80 964-393	INDUCTOR 390 μ H.10%	L1.L2	2
35				
36	10 412-115	WIDERST.NETZW.150 Ω .2%	R1.22.23.24.25.46.52	1
37	80 250-257	POTENTIOMETER.2K	R47	1
38	95 413-325	POTENTIOMETER.25K	R69	1
39				
40	475000-825	RESIS.8.2M Ω .1/4W.5%	R82	1
41	90 364-105	RESIS.1M Ω .1/4W.5%	R97	1
42	89 284-157	RESIS.432 Ω .1/4W.1%	R73.R74	2
43	89 284-216	RESIS.1.78K .1/4W.1%	R35	1
44	89 284-313	RESIS.18.2K .1/4W.1%	R78.R79	2
45	89 284-325	RESIS.24.3K .1/4W.1%	R86.R87	2
46	89 284-340	RESIS.34.8K .1/4W.1%	R54	1
47	89 284-341	RESIS.35.7K .1/4W.1%	R55	1
48	89 284-345	RESIS.39.2K .1/4W.1%	R76.R77	2
49	90 364-121	RESIS.120 Ω .1/4W.5%	R20.R21	2
50	90 364-101	RESIS.100 Ω .1/4W.5%	R43.R44.R84	3
51	90 364-151	RESIS.150 Ω .1/4W.5%	R2.R18.R19	3
52	90 364-221	RESIS.220 Ω .1/4W.5%	R56.R96	2
53	90 364-271	RESIS.270 Ω .1/4W.5%	R37.49.75.90.91.92.93	6
54	90 364-471	RESIS.470 Ω .1/4W.5%	R3.R38	2
55	90 364-102	RESIS.1K .1/4W.5%	R6.7.29.30.36.39.40.50.57.58. R60.62.59.31.71.72	16
56				
57	90 364-122	RESIS.1.2K .1/4W.5%	R17.R27.R66	3
58	90 364-222	RESIS.2.2K .1/4W.5%	R28.41.48.51.65.98	6
59	90 364-332	RESIS.3.3K .1/4W.5%	R8.R9.R53	3
60	90 364-472	RESIS.4.7K .1/4W.5%	R58.R85	2
61	90 364-103	RESIS.10K .1/4W.5%	R4.32.34.61.63.64	6
62	90 364-123	RESIS.12K .1/4W.5%	R70	1
63	90 364-153	RESIS.15K .1/4W.5%	R5	1
64	90 364-223	RESIS.22K .1/4W.5%	R11.13.83.94.95.100	6
65	90 364-473	RESIS.47K .1/4W.5%	R10.R16.R26	3
66	90 364-823	RESIS.82K .1/4W.5%	R14.R15	2

READ / WRITE CONTROL PCB COMPONENTS (CONT.)

88 366 - 001

<u>LFD</u> <u>NR.</u>	<u>TEILE NUMMER</u> <u>PART NUMBER</u>	<u>BENENNUNG</u> <u>DESCRIPTION</u>	<u>REFERENCE</u>	<u>QTY PER ASSY NO:</u> <u>88 365-001</u>
67	90 364-104	RESIS.100K .1/4W.5%	R12.R80	2
68	90 364-183	RESIS.18K .1/4W.5%	R88.R89	2
69	90 364-822	RESIS.8.2K .1/4W.5%	R42.R81	2
70	89 282-628	RESIS.390 Ω .1/2W.5%	R33	1
71	89 282-598	RESIS.22 Ω .1/2W.5%	R99	1
72	81 110-001	RESIS.0.9 Ω .0.35W.5%	R45	1
73	90 366-158	RESIS.150 Ω .2W.5%	R67	1
74				
75	88 353-153	COND.POLY.0.015 μ F.200V.5%	C25	1
76	88 354-393	COND.POLY.0.039 μ F.200V.5%	C26	1
77				
78	98 175-133	COND.CER.330PF.200V.10%	C12.C13	2
79	98 175-168	COND.CER.680PF.200V.10%	C22	1
80	81 119-104	COND.CER.0.1 μ F.63V.10%	C19.20.21.23.30.31.32	7
81	98 175-156	COND.CER.560PF.200V.10%	C24	1
82	98 175-047	COND.CER.47PF.200V.10%	C14.C34	2
83	81 120-102	COND.1000PF.100V.10%	C27	1
84	81 119-224	COND.0.22 μ F.63V.10%	C28	1
85				
86	305028-103	COND.CER.0.01 μ F.100V.20%	C4.6.8.10.15.18.29	7
87	81 091-336	COND.TAN.33 μ F.6.3V.20%	C1	1
88	81 093-226	COND.TAN.22 μ F.16V.20%	C2	1
89	81 095-225	COND.TAN.2.2 μ F.25V.20%	C3	1
90	81 172-476	COND.ALU-ELKO 47 μ F.10V	C7.9.11	3
91	81 173-476	COND.ALU-ELKO 47 μ F.16V	C5	1
92	81 095-685	COND.TAN.6.8 μ F.25V.20%	C16.C17	2
93	80 833-203	PIN-CONNECTOR	J6	1
94	80 833-205	PIN-CONNECTOR	J2	1
95	80 833-209	PIN-CONNECTOR	J3	1
96				
97				
98	81 185-203	PIN-CONNECTOR	JJ1	1
99	81 185-204	PIN-CONNECTOR	JJ2	1

READ / WRITE CONTROL PCB COMPONENTS (CONT.)

88 366 - 001

<u>LFD</u> <u>NR.</u>	<u>TEILE NUMMER</u> <u>PART NUMBER</u>	<u>BENENNUNG</u> <u>DESCRIPTION</u>	<u>REFERENCE</u>	<u>QTY PER ASSY NO:</u> <u>88 366-001</u>
100	81 185-206	PIN-CONNECTOR	JJ1	1
101	81 185-207	PIN-CONNECTOR	JJ2,JJ3,JJ4	3
102				
103	97 272-001	IC-SOCKET.14 POLIG	4D	1
104				
105	355031-Y02	TESTPUNKTE	TP1	1
106	80 976-002	JUMPER.VERZINNT		11
107	88 359-001	POWER CONNECTOR 4 POL.	J5	1
108				
109				
110				

READ / WRITE CONTROL PCB COMPONENTS (CONT.)

88 366 - 001

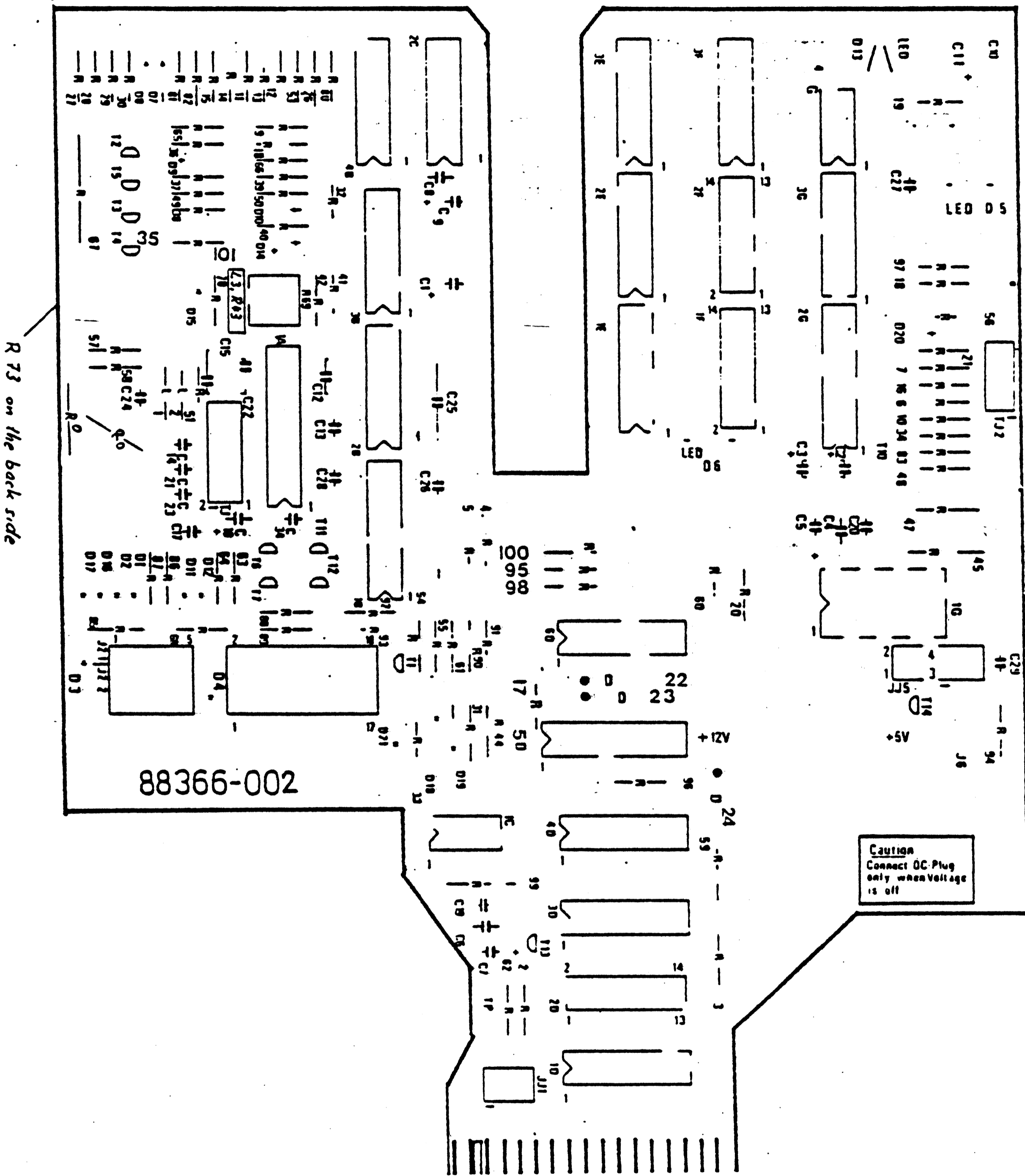

PRINTED CIRCUIT BOARD (PCB).

MDD. 6106 - 88 366-002.

<u>LFD</u> <u>NR.</u>	<u>TEILE NUMMER</u> <u>PART NUMBER</u>	<u>BENENNUNG</u> <u>DESCRIPTION</u>	<u>REFERENCE</u>	<u>QTY PER ASSY NO:</u> <u>88366-002</u>
1				
2				
3				
4	19 296-001	IC SN 7402	3F	1
5	92 127-001	IC SN 7404	1E.3D.2C	3
6	97 607-001	IC SN 7407	3B	1
7	18 773-001	IC SN 7432	2E	1
8	13 602-001	IC SN 7438	1D.6D	2
9	92 136-001	IC SN 7474	2B.3E.3G	3
10	14 588-001	IC SN 74221	1B	1
11	385014-001	IC SN 75453	4G.1C	2
12	94 526-001	IC 9602	2G	1
13	12 282-001	IC LM 339	4B	1
14	80 955-001	IC 3470	1A	1
15	80 937-001	IC SAA 1027	5D	1
16	80 938-001	IC ESM 227N	1G	1
17				
18	90 346-051	Diode 1N751A(5.1V)	D22.24	2
19	10 357-001	Diode 1N4444	D1.2.10.11.12.14.15.16.17.18.19	11
20				
21	90 344-001	Diode 1N4001	D3.4.21	3
22	330705-001	L.Diode ME60	D5.6	2
23	80 975-001	L.Diode LD 52C	D13	1
24	17 202-043	ZENER Diode ZPD 4.3.2Z	D7	1
25	90 346-082	Diode 1N765A(8.2V)	D8.20	2
26	90 346-068	Diode 1N754A(6.8V)	D9	1
27	90 346-036	Diode 1N747A(3.6V)	D23	1
28	80 939-001	TRANSISTOR BC338-16	T14	1
29	80 935-001	TRANSISTOR BC 328-40	T1.2.13	3
30	90 327-001	TRANSISTOR 2N3906	T3.4.5.10	4
31	81 082-001	TRANSISTOR FET J174	T6.7	2
32	90 326-001	TRANSISTOR 2N3904	T11.12	2

READ / WRITE CONTROL PCB COMPONENTS

88 366 - 002

<u>LFZ</u> <u>NR.</u>	<u>TEILE NUMMER</u> <u>PART NUMBER</u>	<u>BENENNUNG</u> <u>DESCRIPTION</u>	<u>REFERENCE</u>	<u>QTY PER ASSY NO:</u> <u>88366-002</u>
33				
34	80 964-153	INDUCTOR 1M2-150 μ H.10%	L1.2	2
35	495004-224	INDUCTOR 1M2-220 μ H.10%	L3	1
36	10 412-115	WIDERST.NETZW.150 Ω ,2%	R1.22.23.24.25.46.52	1
37	80 250-257	POTENTIOMETER 2K	R47	1
38	95 413-325	POTENTIOMETER 25K	R69	1
39				
40	475000-825	RESIS.8.2M Ω .1/4W.5%	R82	1
41	90 364-105	RESIS.1M Ω .1/4W.5%	R97	1
42	89 284-188	RESIS.909 Ω .1/4W.1%	R51	1
43	89 284-216	RESIS.1.78K .1/4W.1%	R35	1
44	89 284-132	RESIS.237 Ω .1/4W.1%	R43	1
45	89 284-325	RESIS.24.3K .1/4W.1%	R86.87	2
46	89 284-340	RESIS.34.8K.1/4W.1%	R54	1
47	89 284-341	RESIS.35.7K .1/4W.1%	R55	1
48	89 284-154	RESIS.402 Ω .1/4W.1%	R57.58	2
49	90 364-121	RESIS.120 Ω .1/4W.5%	R20.21	2
50	90 364-101	RESIS.100 Ω .1/4W.5%	R44	1
51	90 364-151	RESIS.150 Ω .1/4W.5%	R2.18.19	3
52	90 364-221	RESIS.220 Ω .1/4W.5%	R56.96	2
53	90 364-271	RESIS.270 Ω .1/4W.5%	R37.49.90.91.92.93.	6
54	90 364-471	RESIS.470 Ω .1/4W.5%	R3.38	2
55	90 364-102	RESIS.1K . .1/4W.5%	R6.7.29.30.36.39.40.50.31.60	12
56			R62.59	
57	90 364-122	RESIS.1.2K .1/4W.5%	R17.27.66	3
58	90 364-222	RESIS.2.2K .1/4W.5%	R28.41.48.65.98	5
59	90 364-332	RESIS.3.3K .1/4W.5%	R8.9.53	3
60	90 364-472	RESIS.4.7K. .1/4W.5%	R68.85	2
61	90 364-103	RESIS.10K .1/4W.5%	R4.32.61.34.63.64	6
62	90 364-123	RESIS.12K .1/4W.5%	R70	1
63	90 364-153	RESIS.15K .1/4W.5%	R5	1
64	90 364-223	RESIS.22K .1/4W.5%	R11.13.83.94.95.100	6
65	90 364-473	RESIS.47K .1/4W.5%	R10.16.26	3

READ / WRITE CONTROL PCB COMPONENTS (CONT.)

88 366 - 002

LD NR.	TEILE NUMMER PART NUMBER	BENENNUNG DESCRIPTION	REFERENCE	QTY PER ASSY NO: 88366-002
66	90 364-823	RESIS.82K .1/4W.5%	R14.15	2
67	90 364-104	RESIS.100K .1/4W.5%	R12.80	2
68	90 364-183	RESIS.18K .1/4W.5%	R88.89	2
69	90 364-822	RESIS.8.2K .1/4W.5%	R42.81	2
70	89 282-628	RESIS.390 Ω .1/2W.5%	R33	1
71	89 282-598	RESIS.22 Ω .1/2W.5%	R99	1
72	81 110-001	RESIS.0.9 Ω .0.35W.5%	R45	1
73	90 366-158	RESIS.150 Ω .2W.5%	R67	1
74	90 364-393	RESIS.39K .1/4W.5%	R73	1
75	88 353-153	KOND.PLOY.0.015μF.200V	C25	1
76	88 354-393	KOND.PLOY.0.039μF.200V	C26	1
77				
78	98 175-133	KOND.CER.330PF.200V.10%	C12.13	2
79	98 175-222	KOND.CER.2.2NF.50V.10%	C22	1
80	81 119-104	KOND.CER.0.1uF.50V.10%	C19.20.21.23	4
81	98 175-212	KOND.CER.1.2NF.100V.10%	C24	1
82	98 175-047	KOND.CER.47PF.200V.10%	C34	1
83	81 120-102	KOND.CER.1000PF.100V.10%	C27	1
84	81 119-224	KOND.CER.0.22μF.63V.10%	C28	1
85	98 175-115	KOND.CER.150PF.200V.10%	C14	1
86	305028-103	KOND.CER.0.01μF.100V.20%	C4.6.8.10.15.18	6
87	81 091-336	KOND.TAN.33μF.6.3V.20%	C1	1
88	81 093-226	KOND.TAN.22μF.16V.20%	C2	1
89	81 095-225	KOND.TAN.2.2μF.35V.20%	C3	1
90	81 172-476	KOND.ALU-ELKO.47μF.10V	C7.9.11	3
91	81 173-476	KOND.ALU-ELKO.47μF.16V.	C5	1
92	81 095-685	KOND.TAN.6.8μF.25V.20%	C16.17	2
93	80 833-203	PIN-CONNECTOR	J6	1
94	80 833-205	PIN-CONNECTOR	J2	1
95	80 833-209	PIN-CONNECTOR	J3	1
96				
97				
98	81 185-203	PIN-CONNECTOR	JJ1	1
99	81 185-204	PIN-CONNECTOR	JJ2	1

READ / WRITE CONTROL PCB COMPONENTS (CONT.)

88 366 - 002

<u>LFD</u> <u>NR.</u>	<u>TEILE NUMMER</u> <u>PART NUMBER</u>	<u>BENENNUNG</u> <u>DESCRIPTION</u>	<u>REFERENCE</u>	<u>QTY PER ASSY NO:</u> <u>88366-002</u>
100	81 185-206	PIN-CONNECTOR	JJ1	1
101	81 185-207	PIN-CONNECTOR	JJ2.JJ3.JJ4	3
102				
103	97 272-001	IC-SOCKEL,14 POLIG	4D	1
104				
105	355031-Y02	TESTPUNKTE		1
106	80 976-002	JUMPER,VERZINNT		11
107	88 359-001	POWER-STECKER,4POLIG		1
108				
109	90 364-393	RESIS.39K,1/4W,5%	R73	1
110	81 077-001	BRÜCKENWIDERST. 0-Ohm	R0	2
111	90 539-156	SCHRUMPFSCHLAUCH		A/R
112				
113				
114				
115				
116				
117				
118				
119				

READ / WRITE CONTROL PCB COMPONENTS (CONT.)

88 366 - 002

ANLAGE 2 ZUM TECHNICAL MANUAL
ATTACHMENT 2 TO THE TECHNICAL MANUAL

ERSATZTEILE KATALOG
SPARE PARTS CATALOG

MODEL 6108 MINI DISK DRIVE

IN DIESEM ERSATZTEILE-KATALOG SIND NUR DIEJENIGEN TEILE-
UND BAUGRUPPEN-NRN. AUFGEListET, DIE BEI DER BASF-AG ALS
ERSATZTEILE VERFÜGBAR SIND.

IN THE PRESENT SPAREPARTS-CATALOG YOU WILL FIND ONLY PARTS
AND ASSY-NOS. WHICH WILL BE AVAILBLE AS SPARE PARTS FROM
BASF-AG.



BASF Aktiengesellschaft
Verkauf - M Datentechnik
68 Mannheim
Tel:0621/4008-380 Telex:462621

Copyright c 1980
by BASF Aktiengesellschaft

Rev. 02

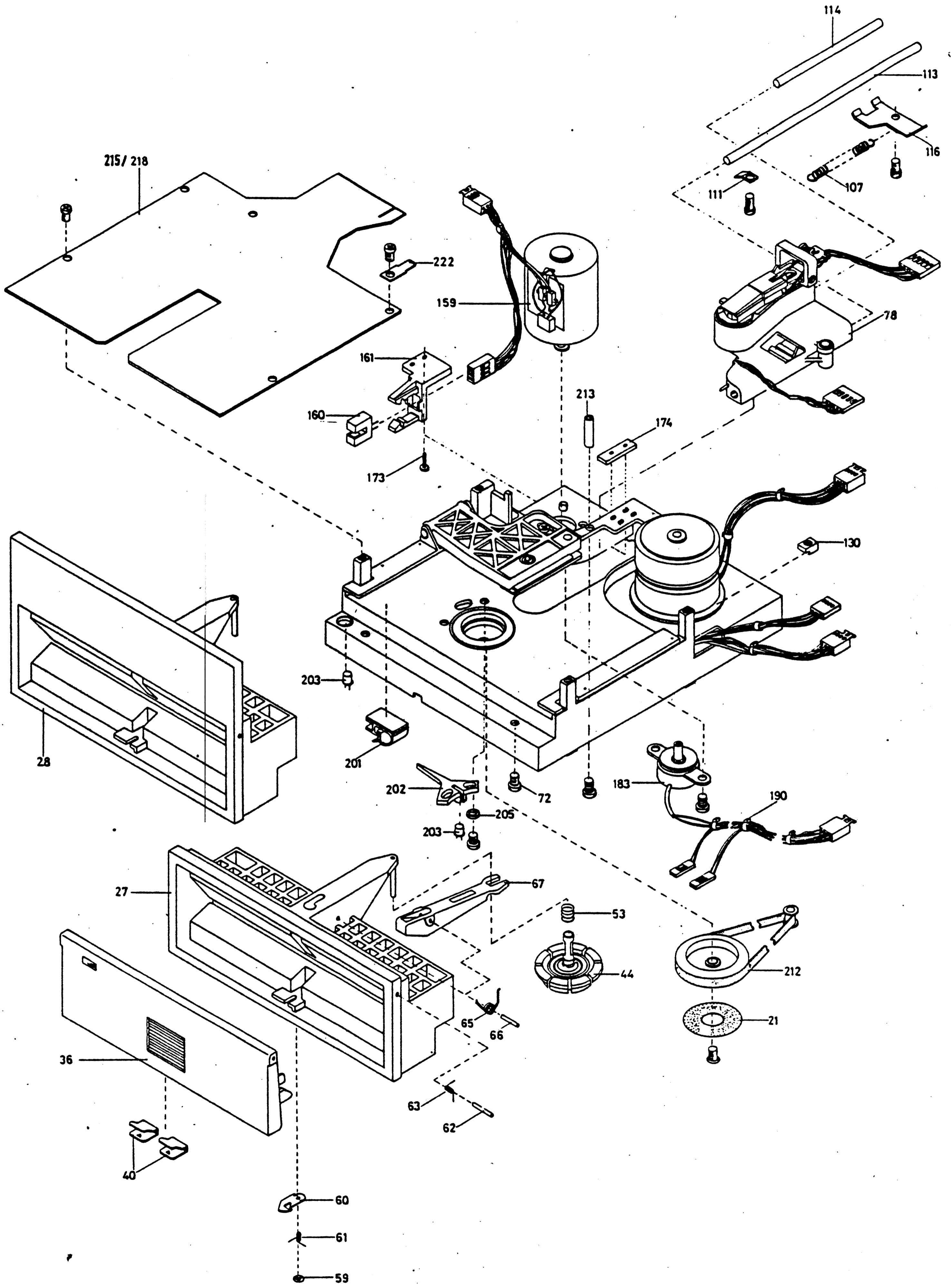

PARTS BREAKDOWN
MOD. 6108

ITEM	PART No.	DESCRIPTION	QTY PER ASSY NO: 88 107- xxx					
			x01	x03	x07			
21	88 421-001	LABEL,TACHOSCOPE	1	1	1			
27	88 126-001	ASSY,FRONT CABINETT	1	1	-			
28	88 126-002	ASSY,FRONT CABINETT SHUGART	-	-	1			
36	88 131-001	ASSY,FRONT DOOR	1	1	1			
40	88 233-001	SPRING FOR DISK TRACKING	2	2	2			
44	88 129-002	ASSY,CONE THRUST	1	1	1			
53	88 404-002	SPRING,COMPRESSION ϕ 8	1	1	1			
59	88 316-020	BENZING-QUICKLOCK 2	1	1	1			
60	88 228-003	LATCH	1	1	1			
61	88 412-003	SPRING,TORSION	1	1	1			
62	88 305-014	PIN,PIVOT ϕ 2x15,8	2	2	2			
63	88 407-001	SPRING,TORSION	2	2	2			
65	88 406-002	SPRING,TORSION	1	1	1			
66	88 305-029	PIN,PIVOT ϕ 3x13,8	1	1	1			
67	88 177-002	LEVER ARM-CONE THRUST	1	1	1			
72	80 958-014	CROSS,RECESSED,SCREW M3x6 5,8						
78	88 163-002	ASSY,CARRIAGE	1	1	1			
107	88 036-001	SPRING,EXTENSION	1	1	1			
111	88 227-001	SPRING,CLAMPING	1	1	1			
113	88 408-001	BAR,GUIDE ϕ 5x130	1	1	1			
114	88 409-001	BAR,GUIDE ϕ 5x71	1	1	1			
116	88 226-001	SPRING,CLAMPING	1	1	1			
130	88 179-001	SHOE,CLAMPING	2	2	2			
157	88 153-Y02	ASSY,SPINDLE MOTOR WITH TRACK O-SWITCH	1	1	1			
158	88 351-001	TRACK O-SWITCH	1	1	1			
159	88 153-Y03	ASSY,SPINDLE MOTOR WITH LIGHT BARRIER	1	1	1			

ITEM	PART No.	DESCRIPTION	QTY PER ASSY NO: 88 107-xxx				
			x 01	x03	x07		
160	88 368-XXX	JOINT LIGHT BARRIER	1	1	1		
161	88 214-001	HOLDER FOR LIGHT BARRIER	1	1	1		
173	89 375-156	CROSS, RECESSED SCREW M 2x8 5,8	2	2	2		
174	88 229-001	NUT PLATE	1	1	1		
183	88 154-001	ASSY, HEAD LOAD SOLENOID	1	1	1		
190	355038-002	TY, WRAP					
201	355027-016	CLAMP, CABLE					
203	505000-001	PHOTO TRANSISTOR	2	2	2		
202	88 207-001	HOLDER TRANSISTOR	1	1	1		
205	88 025-032	WASHER, FLAT 3,2 ST	1	1	1		
212	88 416-003	BELT SPINDLE	1	1	1		
213	88 221-001	THREADED BOLT	1	1	1		
215	88 366-002	PCB, CONTROL	1	1	1		
218 *	88 366-001	PCB, CONTROL	1	1	1		
222	90 473-Y13	FLAT CONNECTOR 4,8	1	1	1		
		O P T I O N S					
236	88 159-001	ASSY, SI-LATCHING MAGNET	-	1	-		
241	80 641-102	CONNECTOR KIT					
242	320015-002	FLAT CONNECTOR P1	1	1	1		
243	98 403-002	FLAT PIN BUSHING 4,8	1	1	1		
244	200218-001	CONTACT LINER	1	1	1		
245	88 360-001	LINING CASE 4 POL P5	1	1	1		
246	80 976-001	SHORT-OUT-CONNECTOR	4	4	4		
		* Use only to order components (see page 6,7,8) If assy needed, order 88 366-002					

CROSS REFERENCE LIST FOR SPARE-PARTS MDD 6108

PART NUMBER	ITEM	PART NUMBER	ITEM
80 641-102	241	88 409-001	114
80 958-014	72	88 412-003	61
80 976-001	246		
		88 416-003	212
88 025-032	205	88 421-001	21
88 036-001	107		
88 126-001	27	89 375-156	173
88 126-002	28		
88 129-002	44	90 473-Y13	222
88 131-001	36		
88 153-Y02	157	98 403-002	243
88 153-Y03	159		
88 154-001	183	200218-001	244
88 159-002	236		
88 163-002	78	320015-002	242
88 177-002	67		
88 179-001	130	355027-016	201
88 207-001	202	355038-002	191
		505000-001	203
88 214-001	161		
88 221-001	213		
88 226-001	116		
88 227-001	111		
88 228-003	60		
88 229-001	174		
88 233-001	40		
88 305-014	62		
88 305-029	66		
88 316-020	59		
88 351-001	158		
88 360-001	245		
88 366-001	218		
88 366-002	215		
88 368-XXX	160		
88 404-002	53		
88 406-002	65		
88 407-001	63		
88 408-001	113		

REF. DESIGN.	PART NO.	DESCRIPTION	QTY PER ASSY NO: 88 366-001				
R8,9,53	90 364-332	RESISTOR 3,3K,1/4W,5%	3				
R10,16,26	90 364-473	RESISTOR 47 K,1/4W,5%	3				
R11,13,83,94,95, R100	90 364-223	RESISTOR 22 K,1/4W,5%	6				
R12,80	90 364-104	RESISTOR 100K,1/4W,5%	2				
R14,15	90 364-823	RESISTOR 82K,1/4W,5%	2				
R17,27,66	90 364-122	RESISTOR 1,2K,1/4W,5%	3				
R20,21	90 364-121	RESISTOR 120Ω,1/4W,5%	2				
R28,41,48,51,65,98	90 364-222	RESISTOR 2,2K,1/4W,5%	6				
R33	89 282-628	RESISTOR 390Ω,1/4W,5%	1				
R35	89 284-216	RESISTOR 1,78K,1/4W,1%	1				
R37,49,75,90,91,92, R93	90 364-271	RESISTOR 270Ω,1/4W,5%	7				
R42,81	90 364-822	RESISTOR 8,2K,1/4W,5%	2				
R43,44,84	90 364-101	RESISTOR 100Ω,1/4W,5%	3				
R45	81 110-001	RESISTOR 0,9Ω,0,35W,5%	1				
R47	80 250-257	RESISTOR POTI 2K	1				
R54	89 284-340	RESISTOR 34,8K,1/4W,1%	1				
R55	89 284-341	RESISTOR 35,7K,1/4W,1%	1				
R56,96	90 364-221	RESISTOR 220Ω,1/4W,5%	2				
R67	90 366-158	RESISTOR 150Ω,2W,5%	1				
R68,85	90 364-472	RESISTOR 4,7K,1/4W,5%	2				
R69	95 413-325	RESISTOR POTI 25K	1				
R70	90 364-123	RESISTOR 12K,1/4W,5%	1				
R73,74	89 284-157	RESISTOR 432Ω,1/4W,1%	2				
R76,77	89 284-345	RESISTOR 39,2K,1/4W,1%	2				
R78,79	89 284-313	RESISTOR 18,2K,1/4W,1%	2				
R82	475000-825	RESISTOR 8,2MΩ,1/4W,5%	1				
R86,87	89 284-325	RESISTOR 24,3K,1/4W,1%	2				
R88,89	90 364-183	RESISTOR 18K,1/4W,5%	2				
R97	90 364-105	RESISTOR 1MΩ,1/4W,5%	1				
R99	89 282-598	RESISTOR 22Ω,1/2W,5%	1				
R45	80 925-001	REPLACEMENT MATER. RESISTOR 0,9Ω,2W,5%	1				
T1,2,13	80 935-001	TRANSISTOR PNP BC 327/40	3				
T3,4,5,8,9,10	90 327-003	TRANSISTOR PNP 2N3906	6				
T6,7	505004-001	TRANSISTOR 2N5460	2				
T11,12	90 326-001	TRANSISTOR NPN 2N3904	2				
T14	80 939-001	TRANSISTOR NPN BC 338-16	1				
1A	80 955-001	IC 3470	1				
1B	14 588-001	IC SN 74221	1				
1C,4G	385014-001	IC SN 74453	2				
1D,6D	13 602-001	IC SN 7438	2				
1E,3D,2C	92 127-001	IC SN 7404	3				
1G	80 938-001	IC ESM 227N	1				
2B,3E,3G	92 136-001	IC SN 7474	3				
2E	18 773-001	IC SB 7432	1				
2G	94 526-001	IC 9602	1				
3B	97 607-001	IC SN 7407	1				

READ/WRITE CONTROL PCB COMPONENTS(CONT.)

REF. DESIGN.	PART NO.	DESCRIPTION	QTY PER ASSY NO: 88 366-001				
3F	19 296-001	IC SN 7402	1				
4B	12 282-001	IC LM 339	1				
5D	80 937-001	IC SAA 1027	1				
1A	97 273-002	IC-SOCKET, 18 POL.	1				
4D	97 272-001	IC-SOCKET, 16 POL.	1				

READ/WRITE CONTROL PCB COMPONENTS(CONT.)

88 366 - 001

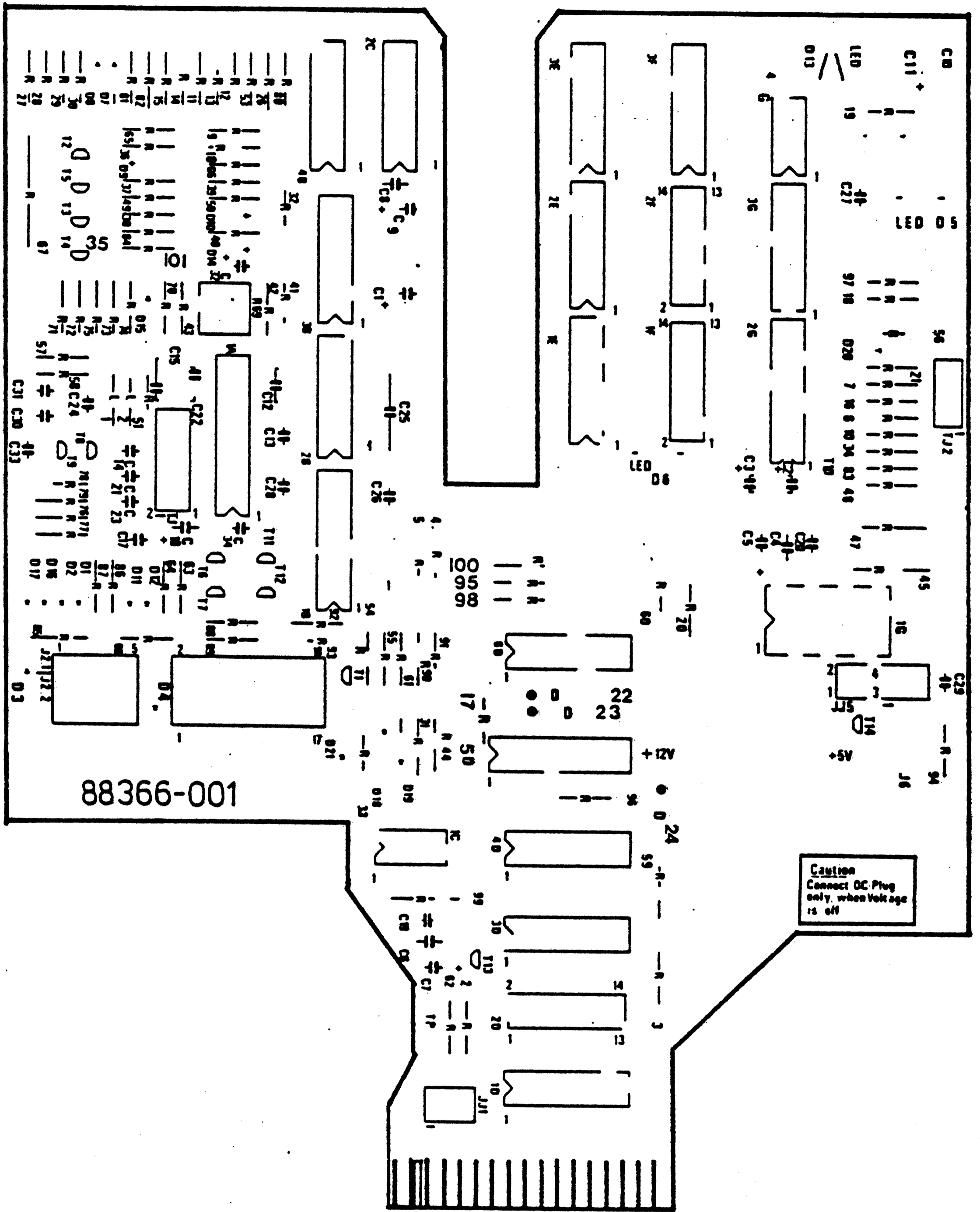

READ/WRITE CONTROL PCB COMPONENT LOCATIONS

6106 MDD 88 366-001

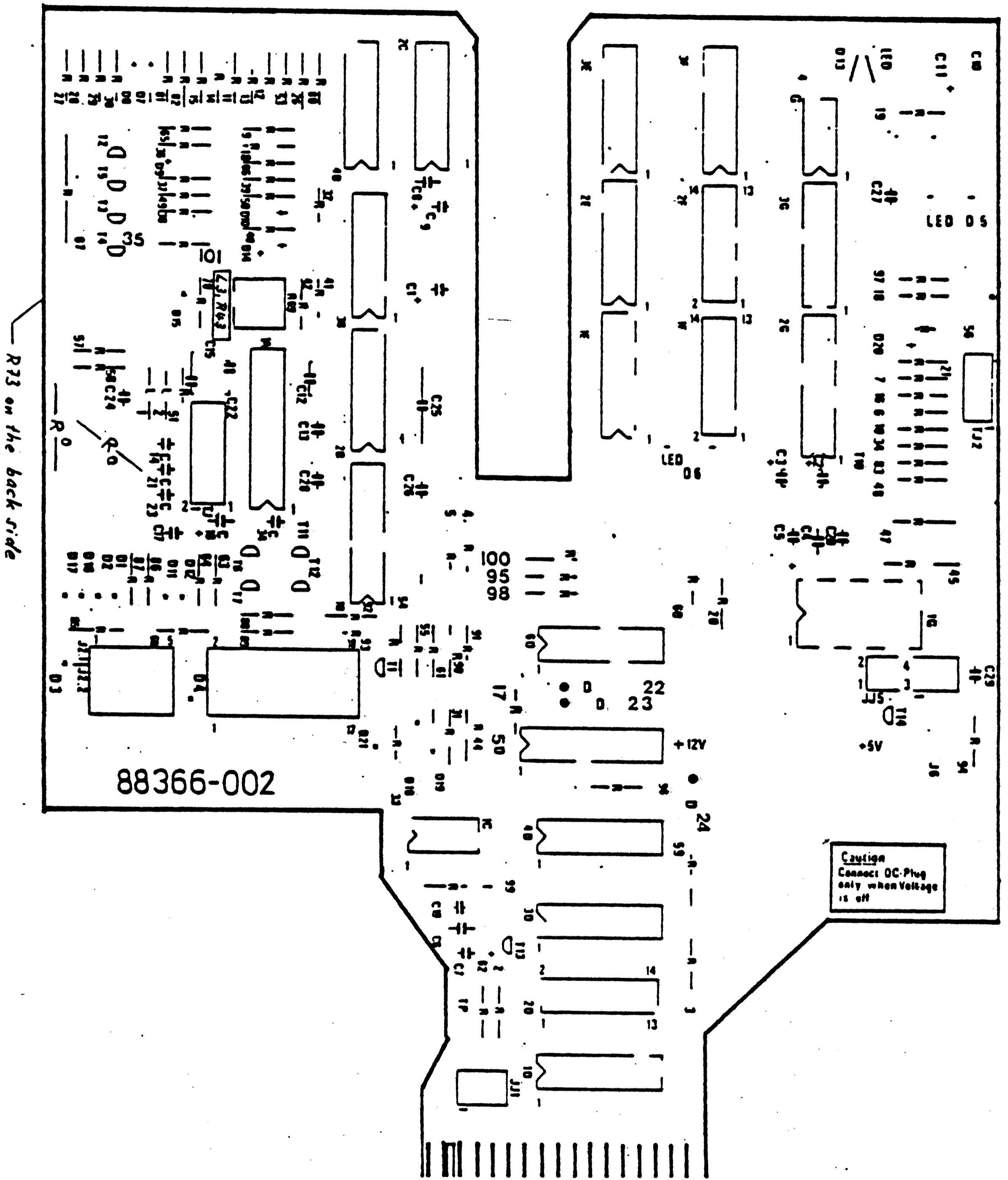

88366-002

Caution
Connect DC Plug
only when Voltage
is off

R73 on the back side

PRINTED CIRCUIT BOARD (PCB).

MDD 6108 - 88 366-002.