

TMS320C54x ***Evaluation Module***

*Technical
Reference*



TMS320C54x Evaluation Module Technical Reference

SPRU135
October 1995



IMPORTANT NOTICE

Texas Instruments (TI) reserves the right to make changes to its products or to discontinue any semiconductor product or service without notice, and advises its customers to obtain the latest version of relevant information to verify, before placing orders, that the information being relied on is current.

TI warrants performance of its semiconductor products and related software to the specifications applicable at the time of sale in accordance with TI's standard warranty. Testing and other quality control techniques are utilized to the extent TI deems necessary to support this warranty. Specific testing of all parameters of each device is not necessarily performed, except those mandated by government requirements.

Certain applications using semiconductor products may involve potential risks of death, personal injury, or severe property or environmental damage ("Critical Applications").

TI SEMICONDUCTOR PRODUCTS ARE NOT DESIGNED, INTENDED, AUTHORIZED, OR WARRANTED TO BE SUITABLE FOR USE IN LIFE-SUPPORT APPLICATIONS, DEVICES OR SYSTEMS OR OTHER CRITICAL APPLICATIONS.

Inclusion of TI products in such applications is understood to be fully at the risk of the customer. Use of TI products in such applications requires the written approval of an appropriate TI officer. Questions concerning potential risk applications should be directed to TI through a local SC sales office.

In order to minimize risks associated with the customer's applications, adequate design and operating safeguards should be provided by the customer to minimize inherent or procedural hazards.

TI assumes no liability for applications assistance, customer product design, software performance, or infringement of patents or services described herein. Nor does TI warrant or represent that any license, either express or implied, is granted under any patent right, copyright, mask work right, or other intellectual property right of TI covering or relating to any combination, machine, or process in which such semiconductor products or services might be or are used.

Preface

Read This First

About This Manual

This document describes the board-level operation of the TMS320C54x evaluation module (EVM).

The TMS320C54x EVM is a PC-AT plug-in card that lets you evaluate certain characteristics of the TMS320C54x digital signal processor (DSP) to determine if the DSP meets your application requirements. You can also create your software to run on board or expand the system in a variety of ways.

Notational Conventions

This document uses the following conventions.

- The TMS320C541 and TMS320C542 processors are referred to collectively as the 'C54x.
- Program listings, program examples, and interactive displays are shown in a special typeface similar to a typewriter's typeface. Here is a sample program listing:

```
@radix 16;
equations
!usrsel_ = !haen_ & !bhe_ & !ha0 &
( ((map==0) & (addr >= 0a40) & (addr < 0a60))
# ((map==1) & (addr >= 0a80) & (addr < 0aa0))
# ((map==2) & (addr >= 0b20) & (addr < 0b40))
# ((map==3) & (addr >= 0b40) & (addr < 0b60)) );
```

Information About Cautions

This book may contain cautions.

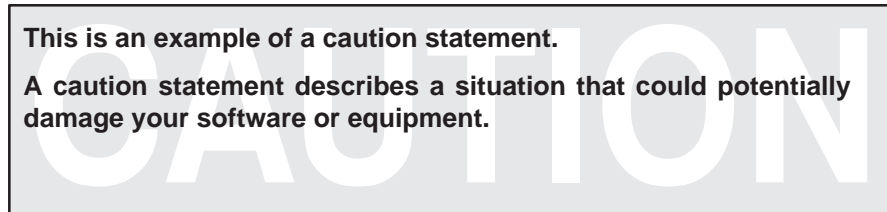

The information in a caution is provided for your protection. Please read each caution carefully.

Related Documentation From Texas Instruments

To obtain a copy of any of these TI documents, call the Texas Instruments Literature Response Center at (800) 477-8924. When ordering, please identify the document by its title and literature number.

TMS320C54x User's Guide (literature number SPRU131) describes the TMS320C54x 16-bit, fixed-point, general-purpose digital signal processors. It describes pin assignments, architecture, internal register structure, instruction set, pipeline, specifications, DMA, and I/O ports. Software and hardware applications are covered in dedicated chapters.

TMS320C54x Assembly Language Tools User's Guide (literature number SPRU102) describes the assembly language tools (assembler, linker, and other tools used to develop assembly language code), assembler directives, macros, common object file format, and symbolic debugging directives for the 'C54x generation of devices.

TMS320C54x Optimizing C Compiler User's Guide (literature number SPRU103) describes the 'C54x C compiler. This C compiler accepts ANSI standard C source code and produces TMS320 assembly language source code for the 'C54x generation of devices.

TMS320C5xx C Source Debugger User's Guide (literature number SPRU099) tells you how to invoke the 'C54x emulator, EVM, and simulator versions of the C source debugger interface. This book discusses various aspects of the debugger interface, including window management, command entry, code execution, data management, and breakpoints. It also includes a tutorial that introduces basic debugger functionality.

If You Need Assistance. . .

If you want to. . .	Do this. . .
Request more information about Texas Instruments Digital Signal Processing (DSP) products	Write to: Texas Instruments Incorporated Market Communications Manager, MS 736 P.O. Box 1443 Houston, Texas 77251-1443
Ask questions about product operation or report suspected problems	Contact the electronic bulletin board: (713) 274-2323
Order Texas Instruments documentation	Call the TI Literature Response Center: (800) 477-8924
Ask questions about product operation or report suspected problems	Call the DSP hotline: (713) 274-2320 FAX: (713) 274-2324
Report mistakes in this document or any other TI documentation	Fill out and return the reader response card at the end of this book, or send your comments to: Texas Instruments Incorporated Technical Publications Manager, MS 702 P.O. Box 1443 Houston, Texas 77251-1443 Electronic mail: comments@books.sc.ti.com

FCC Warning

This equipment is intended for use in a laboratory test environment only. It generates, uses, and can radiate radio frequency energy and has not been tested for compliance with the limits of computing devices pursuant to subpart J of part 15 of FCC rules, which are designed to provide reasonable protection against radio frequency interference. Operation of this equipment in other environments may cause interference with radio communications, in which case the user at his own expense will be required to take whatever measures may be required to correct this interference.

Trademarks

MS-DOS and MS-Windows are registered trademarks of Microsoft Corp.
PC-DOS is a trademark of International Business Machines Corp.

Contents

1	Overview of the TMS320C54x EVM	1-1
	<i>Provides an overview of the TMS320C54x EVM, including its key features and major functions.</i>	
1.1	Key Features of the TMS320C54x EVM	1-2
1.2	Functional Overview of the TMS320C54x EVM	1-3
2	TMS320C54x EVM Host Requirements	2-1
	<i>Describes the minimum hardware configuration required for the TMS320C54x evaluation module.</i>	
2.1	The TMS320C54x EVM Board	2-2
2.2	Host Requirements	2-3
2.3	Host I/O Map Requirements	2-4
3	TMS320C54x EVM Operation	3-1
	<i>Describes the 'C54x EVM, its key components, and how they operate, and provides additional information on the EVM's various interfaces.</i>	
3.1	TMS320C54x Memory Interface	3-2
3.2	PC/AT Host Interface	3-3
3.3	TMS320C54x I/O Interface	3-6
3.4	Host/Target Communications	3-9
3.5	External Serial Port	3-13
3.6	Analog Interface	3-14
	Analog input	3-14
	Analog output	3-15
3.7	Emulation Interface	3-15
3.8	Applications Considerations	3-16
	Shared resources	3-16
	Analog output	3-16
	Parallel I/O	3-17

A	TMS320C54x EVM PAL Equations	A-1
	<i>Contains the programmable logic source for the 'C54x EVM PALS.</i>	
A.1	Host Decode	A-2
A.2	Host Control Strokes	A-4
A.3	Target Control Strokes	A-6
A.4	Miscellaneous Logic	A-8
A.5	Host Interrupt Logic	A-10
A.6	Target Interrupt Logic	A-14
B	TMS320C54x EVM Schematics	B-1
	<i>Contains the schematics for the TMS320C54x EVM.</i>	

Figures

1-1	'C54x EVM Connectivity	1-3
2-1	'C54x EVM Board	2-2
3-1	Host Control Register	3-4
3-2	Target Control Register	3-7

Tables

2-1	'C54x EVM Switch Settings for I/O Address Space	2-4
3-1	'C54x EVM Host Interface Register Offsets	3-3
3-2	'C54x EVM Host Interface Register Usage	3-4
3-3	Host Control Register Bit Definitions	3-5
3-4	Host Interrupt Selection	3-6
3-5	'C54x Port Usage	3-7
3-6	Target Control Register Definitions	3-8
3-7	I/O Expansion Bus Signals	3-9
3-8	External Serial Port Signals	3-13

Overview of the TMS320C54x EVM

The TMS320C54x evaluation module (EVM) is a PC/AT plug-in card that lets you evaluate certain characteristics of the 'C54x digital signal processor (DSP) to see if the DSP meets your application requirements. You can also create your software to run on board or expand the system in a variety of ways.

The 'C54x EVM carries a 'C541 DSP on board to allow full-speed verification of 'C54x code. The 'C541 has 5K bytes of on-chip program/data RAM, 28K bytes of on-chip ROM, two serial ports, a timer, access to 64K bytes each of external program and data RAM, and an external analog interface for evaluation of the 'C54x family of devices for a given application.

To simplify code development and shorten debugging time, a graphical, window-oriented debugger is also included. Its friendly, window-, mouse-, and menu-oriented interface reduces learning time and eliminates the need to memorize complex commands. For more information about the debugger, refer to the *TMS320C5xx C Source Debugger User's Guide*.

Topic	Page
1.1 Key Features of the TMS320C54x EVM	1-2
1.2 Functional Overview of the TMS320C54x EVM	1-3

1.1 Key Features of the TMS320C54x EVM

The 'C54x EVM has the following features:

- 'C541 operating at 40 MIPS with 128K words of zero wait-state memory
- Voice-quality analog interface to line I/O or speaker/microphone (user-selectable) via standard RCA connectors
- External serial port
- Parallel I/O expansion bus
- Two 16-bit bidirectional host/target communication channels; one channel contains 64 words of buffering
- Embedded emulation support based on the IEEE 1149.1 standard
- A single 16-bit ISA half card, mappable to one of four I/O locations

1.2 Functional Overview of the TMS320C54x EVM

Figure 1–1 shows the basic configuration and interconnects of the 'C54x EVM, including the host interface, target memory, analog interface, and emulation interface. The 'C54x EVM supports a 16-bit PC/AT-host interface.

The 'C54x interfaces to 128K words of zero wait-state static memory. An external I/O interface supports 16 parallel I/O ports, a serial port, and other I/O features. The I/O connector is a standard, 64-pin DIN connector. The TLC320AC01 analog interface circuit interfaces to the 'C54x serial port. Two RCA connectors provide analog input and output.

A 74ACT8990 supports embedded emulation for the C source debugger and loading of code. There is no on-board boot PROM/EPROM or direct access into the 'C54x memory. User applications communicate to the 'C54x through the host communications port.

Figure 1–1. 'C54x EVM Connectivity

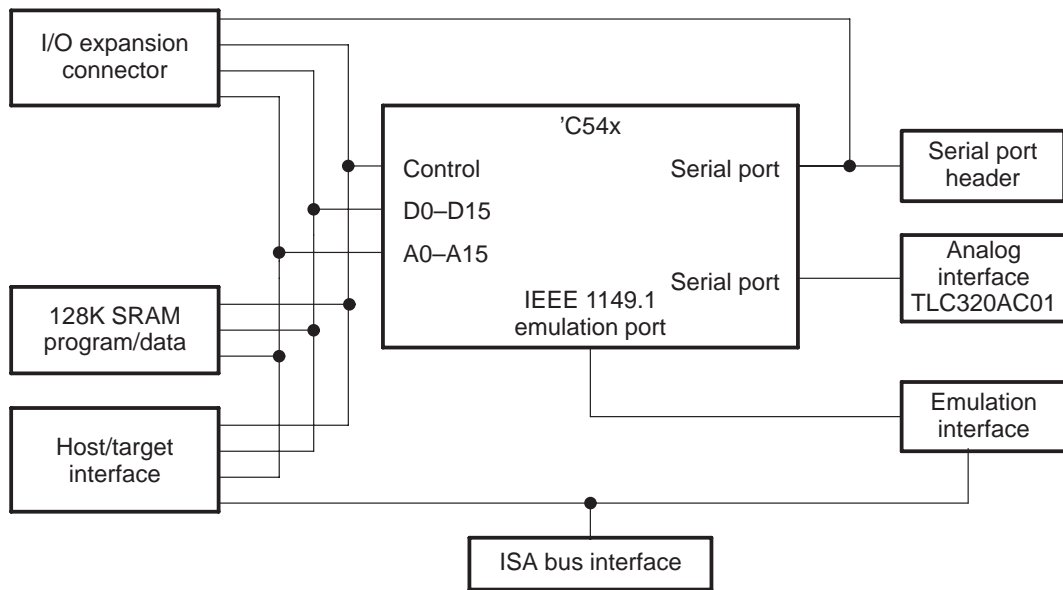

TMS320C54x EVM Host Requirements

This chapter describes PC host requirements for the 'C54x evaluation module (EVM).

Topic	Page
2.1 The TMS320C54x EVM Board	2-2
2.2 Host Requirements	2-3
2.3 Host I/O Map Requirements	2-4

2.1 The TMS320C54x EVM Board

The 'C54x EVM board is a PC/AT half-length board that installs in a vacant 16-bit slot in your PC. Figure 2–1 shows the layout of the 'C54x EVM.

For more information about installing the 'C54x EVM, refer to the *TMS320C54x Evaluation Module Installation Guide*.

Figure 2–1. 'C54x EVM Board

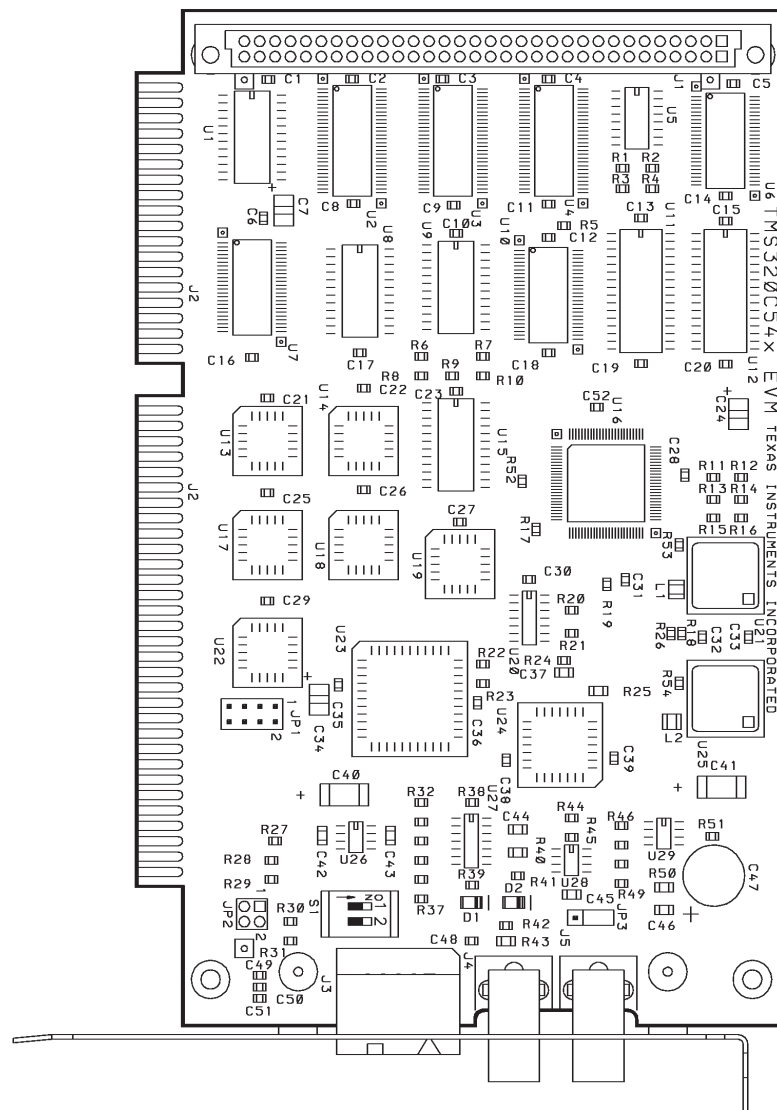

2.2 Host Requirements

To install the EVM board and test and run applications successfully, you need at least a minimum hardware configuration. These are the minimum host system requirements for the 'C54x EVM:

- Host.** An IBM PC/AT or 100%-compatible ISA/EISA-based PC
- Expansion slot.** One 16-bit slot
- I/O bus clock speed.** 8MHz or less
- Memory.** At least 640K bytes of RAM
- I/O space.** 96 bytes (mapped into three, 32-byte pages)
- Power requirements.**
 - 1.5 amps at 5 volts
 - 0.1 amps at -5 volts
 - 0.5 amps at +12 volts
 - 0.1 amps at -12 volts

If you use a daughter card, you might exceed the above current ratings. However, make sure that you do not to exceed the host computer's recommended power ratings.

For more information about installing the 'C54x EVM, refer to the *TMS320C54x Evaluation Module Installation Guide*.

2.3 Host I/O Map Requirements

The 'C54x EVM resides in the host I/O address space. It requires three 32-byte pages, for a total of 96 bytes. Pages are spaced 1K bytes apart. Since PC/AT-compatible machines decode only the first 1K of I/O space, the three pages appear to be mapped on top of one another.

You can map the EVM into one of four I/O base address ranges by setting switches 1 and 2, as shown in Table 2–1. Check your PC system documentation to make sure that the I/O space you have selected does not conflict with other I/O devices such as disk controllers, local area network controllers, etc.

Table 2–1. 'C54x EVM Switch Settings for I/O Address Space

I/O Address Space	Switch #1	Switch #2
0x0240-0x025F page 0	on	on
0x0640-0x065F page 1		default setting
0x0A40-0x0A5F page 2		
0x0280-0x029F page 0	on	off
0x0680-0x069F page 1		
0x0A80-0x0A9F page 2		
0x0320-0x033F page 0	off	on
0x0720-0x073F page 1		
0x0B20-0x0B3F page 2		
0x0340-0x035F page 0	off	off
0x0740-0x075F page 1		
0x0B40-0x0B5F page 2		

TMS320C54x EVM Operation

This chapter describes the 'C54x evaluation module (EVM), its key components, and how they operate. It also provides additional information on the EVM's various interfaces.

The 'C54x EVM consists of seven major blocks of logic:

- 'C54x memory interface
- PC/AT host interface
- 'C54x I/O interface
- Host/target communications interface
- External serial port
- Analog interface
- Emulation interface

Topic	Page
3.1 TMS320C54x Memory Interface	3-2
3.2 PC/AT Host Interface	3-3
3.3 TMS320C54x I/O Interface	3-6
3.4 Host/Target Communications	3-9
3.5 External Serial Port	3-13
3.6 Analog Interface	3-14
3.7 Emulation Interface	3-15
3.8 Applications Considerations	3-16

3.1 TMS320C54x Memory Interface

The EVM includes 64K words of zero wait-state program memory and 64K words of zero wait-state data memory, providing a total of 128K words of external memory. Two important conditions affect memory usage:

- **Memory precedence.** Internal memory, when enabled, takes precedence over external memory. If you want to use external memory at locations that correspond to internal memory locations, you must disable those on-chip memories at run time. Refer to the *TMS320C54x User's Guide* for more information.
- **Wait states.** External memory is subject to automatic wait-state insertion. If you want to access external memory without wait states, you must set the on-chip wait-state generator to zero wait states for program and data memory. Refer to the *TMS320C54x User's Guide* for more information.
 - For the 'C54x memory, no wait states or program/data bank switching delay is necessary.
 - For the 'C54x host interface I/O, two or more wait states are required. However, external I/O devices of your own may require more wait states. Refer to the *TMS320C54x User's Guide* for more information about the software-programmable wait-state generator.

3.2 PC/AT Host Interface

The PC/AT interface provides the buffering, host I/O decode, and access control. The PC/AT host communicates to the 'C54x EVM via 38 16-bit I/O locations. Each I/O location is defined by the I/O page 0 address described by an offset. The first 32 I/O locations support emulation. The remaining six locations support host/target communications and control. The I/O offsets are defined in Table 3–1.

Table 3–1. 'C54x EVM Host Interface Register Offsets

I/O Offset From Base Address	Register	Size	Register Type
0x0000–0x01F	Test bus controller	16	Read/write
0x0400–0x41F	Test bus controller	16	Read/write
0x0800	Channel A	16	Read/write
0x0802	Reserved	16	Read/write
0x0804	Channel B	16	Read/write
0x0806	Channel B	16	Read/write
0x0808	Status/control	16	Read/write
0x080A	Status/control	16	Read/write

Note: All locations are defined as 16-bit words. The EVM hardware ignores byte accesses.

Register usage is summarized in Table 3–2.

Table 3–2. 'C54x EVM Host Interface Register Usage

Register	Description
Test bus controller	Used for emulation
Channel A	<p>A single, bidirectional register for transferring commands and data</p> <ul style="list-style-type: none"> <input type="checkbox"/> Host writes to channel A (offset 0x0800) overwrite the current value and generate an INT1 to the target, set the AXST bit (bit 0) in the host control register, and set the ARST bit (bit 1) in the target control register. <input type="checkbox"/> Host reads to the same location clear the ARST bit (bit 1) in the host control register and clear the AXST bit (bit 0) in the target control register.
Channel B	<p>A 64-deep, bidirectional first-in first-out (FIFO) register for transferring commands and data</p> <ul style="list-style-type: none"> <input type="checkbox"/> Host writes to either location (0x0804 or 0x0806) are buffered by the FIFO. Data is ignored if the channel is full. <input type="checkbox"/> Host writes to offset 0x0806 have the side effect of generating an INT2 on the target. A transmit-FIFO-full signal also generates an INT2 on the target.
Status/control	<p>A register that provides system-level control and status for the EVM. Host writes to offsets 0x0808 and 0x080A are identical except that writes to offset 0x080A reset the ARST, AXST, BRST, and BXST flags for the host and target and the BRST2 flag for the host. This should be done by the host at the start of the host/target communications. Note that the debugger resets (via the RESET bit) the target and emulation only.</p>

The host control register is shown in Figure 3–1; the bit definitions are shown in Table 3–3. See Section 3.4 on page 3-9 for details of host/target communications.

Figure 3–1. Host Control Register

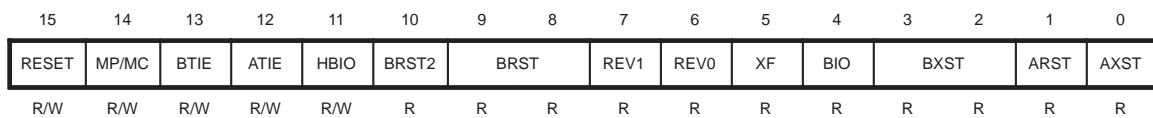

Note: Writes to read-only bits have no effect.

Table 3–3. Host Control Register Bit Definitions

Bit	Name	Description															
0	AXST	Channel A transmit status. If AXST = 1, the host has written to its channel A register. The AXST flag is cleared when the target reads channel A.															
1	ARST	Channel A receive status. If ARST = 1, the target has written to its channel A register. The ARST flag is cleared when the host reads channel A.															
3–2	BXST	Channel B transmit status: <table border="1" data-bbox="503 661 1063 892"> <thead> <tr> <th>Bit 3</th> <th>Bit 2</th> <th>Channel B Transmit Status</th> </tr> </thead> <tbody> <tr> <td>0</td> <td>0</td> <td>buffer empty</td> </tr> <tr> <td>0</td> <td>1</td> <td>buffer less than half full</td> </tr> <tr> <td>1</td> <td>1</td> <td>buffer half or more full</td> </tr> <tr> <td>1</td> <td>0</td> <td>buffer full</td> </tr> </tbody> </table>	Bit 3	Bit 2	Channel B Transmit Status	0	0	buffer empty	0	1	buffer less than half full	1	1	buffer half or more full	1	0	buffer full
Bit 3	Bit 2	Channel B Transmit Status															
0	0	buffer empty															
0	1	buffer less than half full															
1	1	buffer half or more full															
1	0	buffer full															
4	BIO	$\overline{\text{BIO}}$ input to target processor															
5	XF	External flag from target processor (status)															
6	REV0	Card revision status bit 0															
7	REV1	Card revision status bit 1															
9–8	BRST	Channel B receive status: <table border="1" data-bbox="503 1144 1063 1375"> <thead> <tr> <th>Bit 9</th> <th>Bit 8</th> <th>Channel B Receive Status</th> </tr> </thead> <tbody> <tr> <td>0</td> <td>0</td> <td>buffer empty</td> </tr> <tr> <td>0</td> <td>1</td> <td>buffer less than half full</td> </tr> <tr> <td>1</td> <td>1</td> <td>buffer half or more full</td> </tr> <tr> <td>1</td> <td>0</td> <td>buffer full</td> </tr> </tbody> </table>	Bit 9	Bit 8	Channel B Receive Status	0	0	buffer empty	0	1	buffer less than half full	1	1	buffer half or more full	1	0	buffer full
Bit 9	Bit 8	Channel B Receive Status															
0	0	buffer empty															
0	1	buffer less than half full															
1	1	buffer half or more full															
1	0	buffer full															
10	BRST2	Channel B receive status bit 2. If BRST2 = 1, the target has written to channel B, forcing an interrupt. The BRST2 flag is cleared when the host reads its channel B.															
11	HBIO	Host $\overline{\text{BIO}}$ input to target processor															
12	ATIE	Channel A target interrupt enable. If ATIE = 1, channel A receive conditions generate a host interrupt.															
13	BTIE	Channel B target interrupt enable. If BTIE = 1, channel B receive conditions generate a host interrupt.															
14	MP/MC	Microprocessor/microcomputer mode select. The EVM powers up in microcomputer mode.															
15	RESET	Software reset. If RESET = 1, the target processor and emulation logic are reset, but the host/target communication flags are not reset.															

The target processor can interrupt the host under certain conditions. For more details, see Section 3.4, *Host/Target Communications*, on page 3-9. You can select from four host interrupts: IRQ5, IRQ7, IRQ10, and IRQ11. Configure jumper block JP1 to select the appropriate interrupt. JP1 jumper settings are shown in Table 3–4.

Table 3–4. Host Interrupt Selection

Host Interrupt	JP1 Jumper Setting
IRQ5	Pins 1–2
IRQ7	Pins 3–4
IRQ10	Pins 5–6
IRQ11	Pins 7–8

Note: The EVM is shipped without a jumper installed on JP1.

3.3 TMS320C54x I/O Interface

The EVM supports two communications channels configured as six I/O ports for host/target communication and sixteen I/O ports for user expansion.

Port usage is summarized as follows:

- Sixteen parallel I/O ports (**PIO**) are for applications and are available on the parallel expansion connector J1, an industry standard 64-pin female DIN connector. The I/O port address, control, and data signals are buffered. You can extend the I/O wait states with the READY signal.
- The host/target message communication system provides a simple means to pass data between the target and host while maintaining real-time operation. The message protocol is user-defined. The system can be interrupt-driven, polled, or a mixture of the two. Channels A and B can be used to pass information between the host and target:
 - **Channel A** is a single 16-bit bidirectional register mapped into two I/O port locations. Both locations are identical for reads. Target writes to location 0x0010 generate a host interrupt *only* if the host control bit ATIE is set. Target writes to location 0x0011 generate a host interrupt regardless of the value of ATIE. The only exception to this is when both ATIE and BTIE have been zero since the last interrupt was serviced. In this case, it is necessary to cycle either ATIE or BTIE high and then low in order to use this feature (target write generating a host interrupt).

- **Channel B** is a single, bidirectional, 64-deep, first-in first-out (FIFO) buffer that is also mapped into two I/O port locations. Both locations are identical for reads. If the host control bit BTIE is set, writes to either location that fill the buffer generate a host interrupt. If BTIE is set, writes to port 0x0013 generate a host interrupt whether the FIFO buffer is full or not.

You can use channels A and B independently or together.

- A **status** I/O port is for target control and provides general-purpose control, status, and discrete bit I/O. USRBIN0 and USRBIN1, and USBOT0, USBOT1, and USBOT2 are discrete TTL-compatible inputs and outputs, respectively, that are available for use on the expansion connectors. Inputs are pulled high with 4.7K resistors.

All I/O accesses require at least two wait states; use the 'C54x software-programmable wait-state generator to provide these wait states. Refer to the *TMS320C54x User's Guide* for information about the software-programmable wait-state generator.

Table 3–5 shows target I/O port usage.

Table 3–5. 'C54x Port Usage

Port Address	Name	Usage
0x0000–0x000F	PIO	User expansion
0x0010	Channel A	Communications
0x0011	Channel A	Communications
0x0012	Channel B	Communications
0x0013	Channel B	Communications
0x0014	Status	Target status/control
0x0015	Reserved	Reserved
0x0016–0xFFFF	Reserved	Reserved

The target control register is shown in Figure 3–2; the bit definitions are shown in Table 3–6. See Section 3.4 on page 3-9 for details of host/target communications.

Figure 3–2. Target Control Register

15	14	13	12	11	10	9	8	7	6	5	4	3	2	1	0
AIC-RST	USR-BOT2	USR-BOT1	USR-BOT0	Reserved				USR-BIN1	USR-BIN0	BRST	BXST		ARST	AXST	
R/W	R/W	R/W	R/W					R	R	R	R	R	R	R	R

Note: Writes to read-only bits have no effect.

Table 3–6. Target Control Register Definitions

Bit	Name	Description															
0	AXST	Channel A transmit status. If AXST = 1, the target has written to its channel A register. The AXST flag is cleared when the host reads channel A.															
1	ARST	Channel A receive status. If ARST = 1, the host has written to its channel A register. The ARST flag is cleared when the target reads channel A.															
3–2	BXST	Channel B transmit status:															
		<table border="1"> <thead> <tr> <th>Bit 3</th> <th>Bit 2</th> <th>Channel B Transmit Status</th> </tr> </thead> <tbody> <tr> <td>0</td> <td>0</td> <td>buffer empty</td> </tr> <tr> <td>0</td> <td>1</td> <td>buffer less than half full</td> </tr> <tr> <td>1</td> <td>1</td> <td>buffer half or more full</td> </tr> <tr> <td>1</td> <td>0</td> <td>buffer full</td> </tr> </tbody> </table>	Bit 3	Bit 2	Channel B Transmit Status	0	0	buffer empty	0	1	buffer less than half full	1	1	buffer half or more full	1	0	buffer full
Bit 3	Bit 2	Channel B Transmit Status															
0	0	buffer empty															
0	1	buffer less than half full															
1	1	buffer half or more full															
1	0	buffer full															
5–4	BRST	Channel B receive status:															
		<table border="1"> <thead> <tr> <th>Bit 5</th> <th>Bit 4</th> <th>Channel B Receive Status</th> </tr> </thead> <tbody> <tr> <td>0</td> <td>0</td> <td>buffer empty</td> </tr> <tr> <td>0</td> <td>1</td> <td>buffer less than half full</td> </tr> <tr> <td>1</td> <td>1</td> <td>buffer half or more full</td> </tr> <tr> <td>1</td> <td>0</td> <td>buffer full</td> </tr> </tbody> </table>	Bit 5	Bit 4	Channel B Receive Status	0	0	buffer empty	0	1	buffer less than half full	1	1	buffer half or more full	1	0	buffer full
Bit 5	Bit 4	Channel B Receive Status															
0	0	buffer empty															
0	1	buffer less than half full															
1	1	buffer half or more full															
1	0	buffer full															
6	USRBIN0	User discrete input bit 0															
7	USRBIN1	User discrete input bit 1															
8	—	Reserved															
9	—	Reserved															
10	—	Reserved															
11	—	Reserved															
12	USRBOT0	User discrete output bit 0															
13	USRBOT1	User discrete output bit 1															
14	USRBOT2	User discrete output bit 2															
15	AICRST	If AICRST = 0, the analog interface circuit is reset.															

Table 3–7 shows the I/O expansion connector J1 pin assignments.

Table 3–7. I/O Expansion Bus Signals

Row	Column A	Column B	Row	Column A	Column B
1	+5	+5	17	ID14	ID15
2	GND	XCLKOUT	18	GND	GND
3	GND	GND	19	$\overline{\text{INT0}}$	$\overline{\text{INT3}}$
4	$\text{XR}/\overline{\text{W}}$	$\overline{\text{XIOSTRB}}$	20	$\overline{\text{NMI}}$	IACK
5	$\overline{\text{XIS}}$	READY	21	$\overline{\text{X1BIO}}$	XF
6	XA0	XA1	22	TOUT	USRBIN0
7	XA2	XA3	23	USRBOT2	USRBIN1
8	GND	GND	24	USRBOT0	USRBOT1
9	ID0	ID1	25	GND	GND
10	ID2	ID3	26	CLKR0	CLKX0
11	ID4	ID5	27	DR0	DX0
12	ID6	ID7	28	$\overline{\text{FSR0}}$	$\overline{\text{FSX0}}$
13	GND	GND	29	GND	GND
14	ID8	ID9	30	+5	+5
15	ID10	ID11	31	–5	$\overline{\text{RESET}}$
16	ID12	ID13	32	+12	–12

3.4 Host/Target Communications

The 'C54x EVM has two independent communication channels, A and B, through which the host and target can communicate. Features of host and target communications include:

- Two-way, independent transfer. Both channels are bidirectional and fully independent.
- Equal status for host and target. There is no master/slave relationship between the host and the target. Both parties are equal under the specification.
- Polled or interrupt-driven channels. Both channels can be polled or interrupt-driven.

- Mutual status flag availability. In general, status flags for both the host and target sides are available to both the host and the target (the exception is BRST2, which is only available on the host side). See Table 3–3 on page 3-5 and Table 3–6 on page 3-8.
- Individually maskable interrupts on the target side. Target interrupts use separate interrupts: $\overline{\text{INT1}}$ for channel A and $\overline{\text{INT2}}$ for channel B. Both interrupts are individually maskable in the IMR register. Refer to the *TMS320C54x User's Guide* for more details.
- Individually enabled channels on the host side. Both channels must share a single host interrupt (selected by JP1; see Table 3–4 on page 3-6) but are individually enabled by the host by setting the ATIE bits for channel A or the BTIE bits for channel B in the host control register. See Table 3–3 on page 3-5.
- Unqueued interrupts. Interrupts are not queued. Both the host and target interrupts stay active until the host or target reads from the channel that caused the interrupt.
- Handshake-free. Handshaking between the host and target is not required to pass information. When the corresponding read/write operations are complete, the appropriate flags are changed automatically.
- Automatic overwrites. Writes to channel A, a single-word buffer, overwrite the previous contents of the buffer, regardless of whether the data has been read by the other side.
- Immediate data availability. Data written to channel B, a 64-word buffer, is available immediately to the other side on a first-in first-out (FIFO) basis. Data written when the buffer is full will be lost. Once the receiving side reads a word, that space is then available. Essentially, channel B is a bidirectional queue implemented as circular lists of length 64.

Example 3–1 shows the transmission of 47 16-bit words of data and commands from the host to the target. Example 3–2 illustrates the transfer of a continuous data stream from the host to the target; the results are sent back to the host.

Since software development is constantly changing and growing, you can keep up with the latest developments by accessing the TI 24-hour electronic bulletin boards (BBS) with your PC and modem (in the United States and Canada). The TI DSP BBS phone number is (713) 274–2323. Protocol for the BBS is eight data bits, one stop bit, and no parity.

Example 3–1. Sending 47 16-Bit Words of Data and Commands From Host to Target Using Channel B

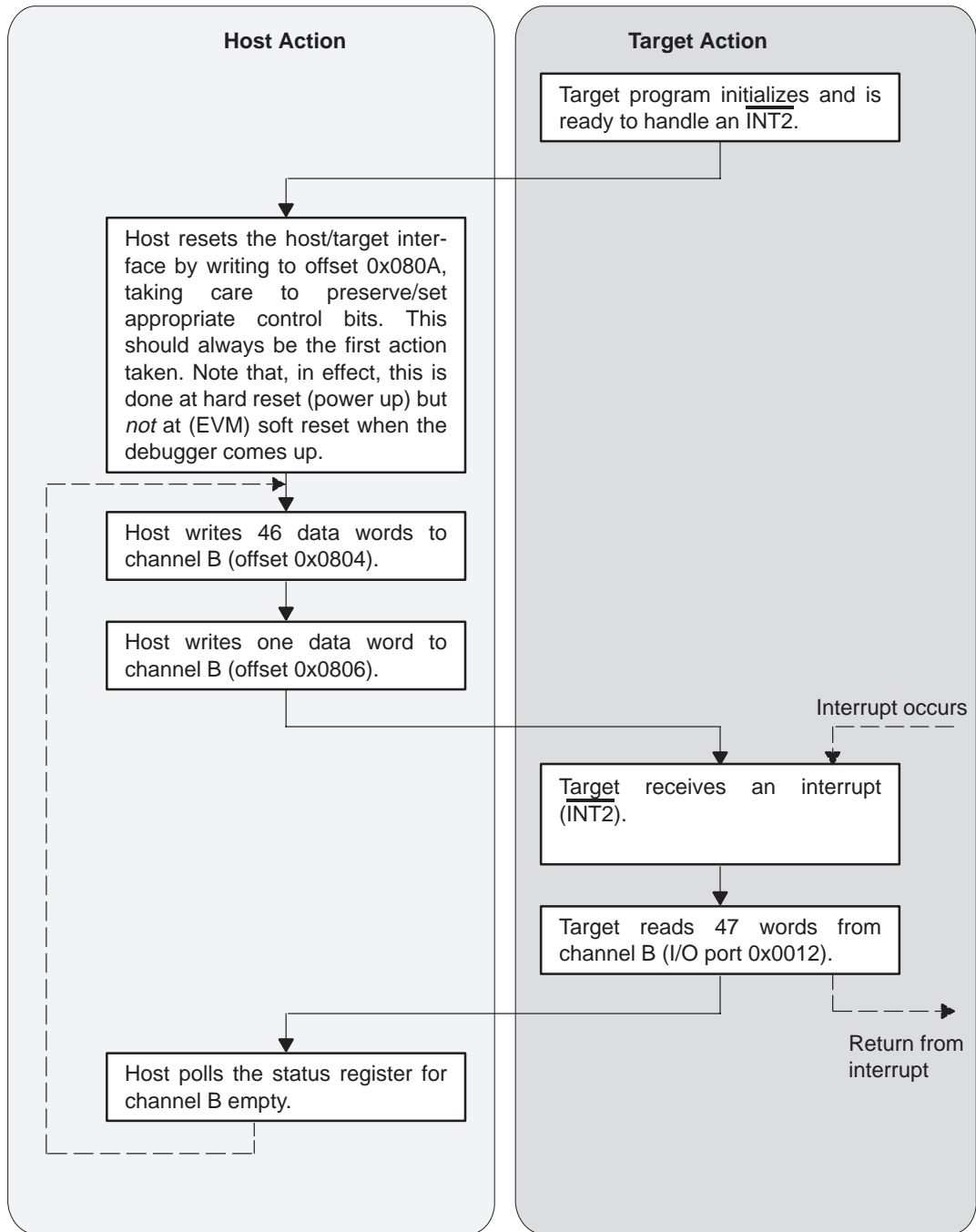

Note: The solid lines represent the data flow, and the dashed lines represent the program flow.

Example 3–2. Transmitting a Continuous Data Stream From Host to Target, Then Sending Results Back to Host Using Channel A

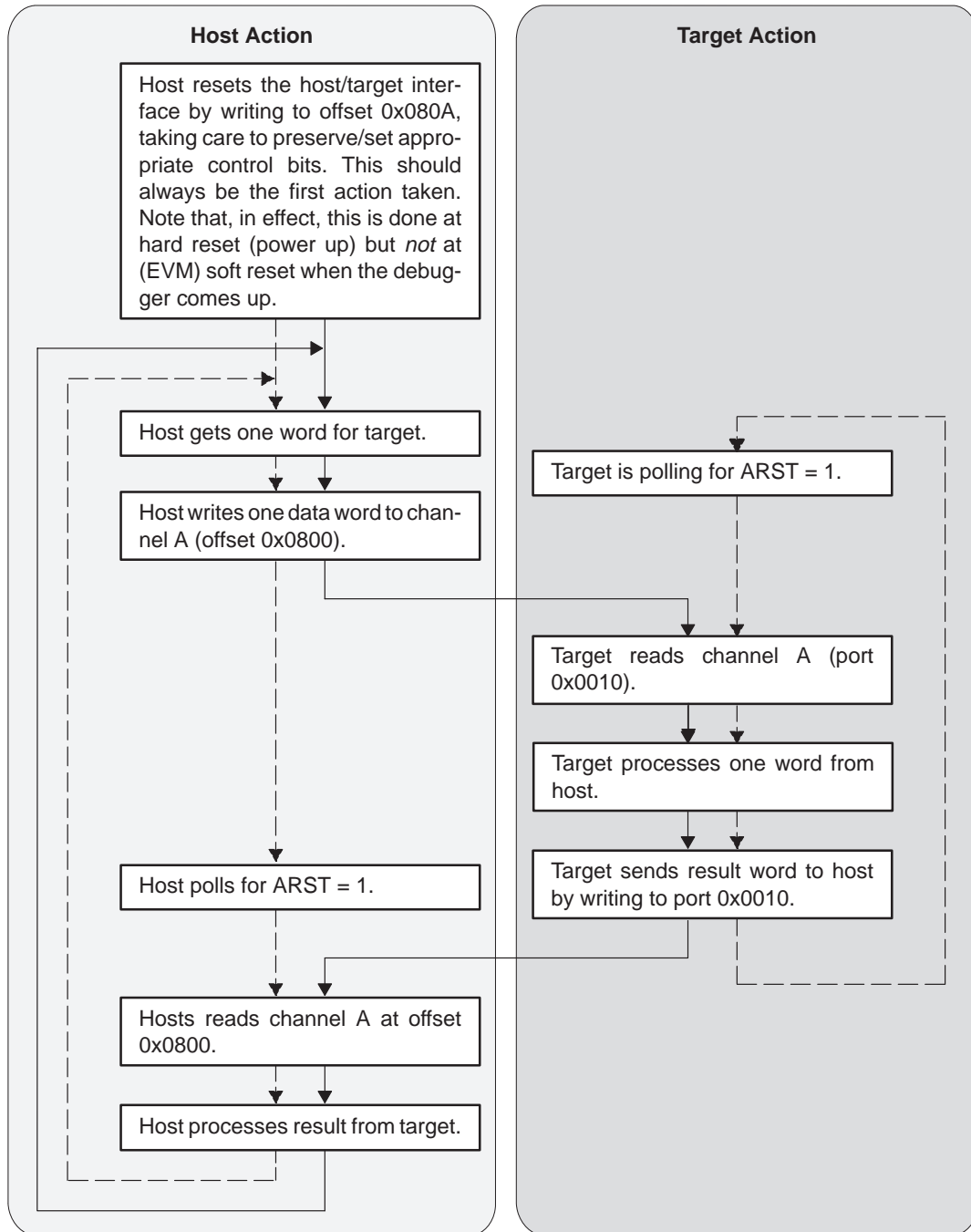

Note: The solid lines represent the data flow, and the dashed lines represent the program flow.

3.5 External Serial Port

The EVM provides one external serial port interface by means of a 10-pin header accessible at the rear of the PC. The serial port interface is connected directly to 'C541 serial port 0. Table 3–8 shows the pin assignments for the serial port interface.

Table 3–8. External Serial Port Signals

Pin	Signal
1	GND
2	$\overline{\text{FSR0}}$
3	CLKX0
4	DR0
5	DX0
6	$\overline{\text{X2BIO}}$
7	$\overline{\text{FSX0}}$
8	XF
9	CLKR0
10	GND

3.6 Analog Interface

The 'C54x EVM provides a single channel of voice-band analog input and output with programmable filtering, scaling, and sampling based on the TLC320AC01 analog interface circuit.

Features of the analog interface circuit include:

- 14-bit analog-to-digital/digital-to-analog (with 16 bits of dynamic range)
- Programmable sample rate (up to 43.2kHz)
- Programmable $\pm 3V$ full scale input
- Programmable $\pm 3V$ full scale output into 300 ohms
or
Can drive an 8-ohm speaker directly (jumper-selectable)
- Programmable anti-aliasing and reconstruction filters

The analog interface circuit is hard-wired in master/standalone mode with $\overline{\text{PWRDWN}}$ pulled high. The target control register (see Table 3–6 on page 3-8) controls the analog interface circuit reset and powers up low.

For applications that use the analog interface circuit, you must set the $\overline{\text{AICRST}}$ signal high before the analog interface circuit will operate. The analog interface circuit interfaces directly to the 'C54x via serial port 1 and generates $\overline{\text{FS}}$ and $\overline{\text{CLK}}$ for both transmit and receive. Clock signals for serial interface and filters are derived from the MCLK input, which comes from a 10.368-MHz crystal oscillator.

Analog input

The analog input for the analog interface circuit is taken from the external connector J4, prefiltered, buffered, referred to ADCMID and fed to the analog interface circuit IN differential inputs.

The analog interface circuit has two sets of inputs, IN and AUXIN, which are software-selectable. The IN signals are the default and are DC-coupled to the analog interface circuit with a gain of one. The AUXIN channel is AC-coupled with a gain of ten, which is useful for small signals such as those taken directly from a microphone.

On either channel, you can increase input sensitivity two or four times through software. For complete instructions on how to do this, refer to the *TLC320AC01 Data Manual*.

Analog output

Analog output (J5) is jumper-selectable (JP3) between one of two sources.

JP3 in the lower position (pins 2 and 3) selects ground-referenced analog interface circuit output. This output will drive $\pm 3V$ full scale into a minimum of 300 ohms. You should find this more than adequate to drive most line-level audio component inputs.

You may reduce full-scale output two or four times through software. This measure is recommended when driving stereophonic equipment. For more complete instructions, refer to the *TLC320AC01 Data Manual*.

To drive speakers as low as 4 ohms directly, put JP3 in the upper position (pins 1 and 2) to select amplified output from a LM386 audio power amplifier.

3.7 Emulation Interface

The 74ACT8990 test bus controller (U23) provides the EVM emulation interface. The test bus controller connects directly to the 'C54x JTAG emulation port. The host interfaces to the test bus controller through 32 16-bit I/O mapped registers. The JTAG test clock (TCK) to the test bus controller is taken from the 10.368 crystal oscillator (U25) that drives the analog interface circuit.

The emulation interface and host/target communications interface can operate independently. The emulation interface features include:

- Emulation supported without external cabling, monitor software, or consumption of user resources
- Easy access to the 'C54x high-level language debuggers, factory testing, field diagnostics, etc.
- No system boot-ROM requirement. The host can download all necessary program files or data through the emulation port.

The EVM was designed so that you can debug a 'C54x application in conjunction with a host application. The only resource shared between the 'C54x debugger and host/target communications interface is the RESET bit of the host control register.

When you invoke a reset command within the debugger, the RESET bit is toggled high and then low to reset the EVM.

Do not reset the EVM outside of the debugger once you have invoked the debugger. To do so will take the 'C54x out of emulation mode.

3.8 Applications Considerations

The 'C54x EVM provides your application with numerous resources, some of which are shared.

Shared resources

In order to function properly, the application must coordinate use of these resources:

- Host control register.** Your application and C source debugger share the RESET bit in this register. The reset command in the debugger cycles this bit high and then low, resetting the EVM. The application program on the host should not reset the EVM when the debugger is running. This will interfere with debugger operation.
- $\overline{\text{BIO}}$ signal.** Three sources are gated together to form the 'C54x $\overline{\text{BIO}}$ signal: $\overline{\text{X1BIO}}$ located on connector J1, $\overline{\text{X2BIO}}$ located on connector J3, and $\overline{\text{HBIO}}$ located in the host control register. If any of these signals are low, the processor $\overline{\text{BIO}}$ signal is low, effectively disabling the other signals.
- XF signal.** The XF signal from the 'C54x is routed to both J1 and J3 unbuffered.
- Serial port.** The EVM provides one external serial port interface by means of a 10-pin header accessible at the rear of the PC. The 'C54x serial port 0 is routed to both J1 and J3.

Analog output

You can use the analog output connector, J5, to drive a low-impedance load such as a speaker (JP3 in upper position, pins 1 and 2) or a high-impedance load (300 ohms or more) such as a stereo amplifier.

When set to drive a high-impedance load (JP3 in lower position, pins 2 and 3), the full-scale output from the EVM is that of the analog interface circuit. This, by default, is $\pm 3\text{V}$, which is well above what most audio components will handle without distortion or clipping.

To avoid potential distortion, reduce the full scale analog interface circuit output to $\pm 0.75\text{V}$ and ensure that JP3 is set to match the load being driven.

Parallel I/O

The parallel I/O available on J1 is buffered such that it requires at least two wait states in order to meet system timing requirements. External parallel I/O devices connected to J1 may require extra wait states or use of the READY signal. Be sure to observe system timing requirements when connecting external parallel I/O devices. For more information on timing and automatic wait-state generation, refer to the *TMS320C54x User's Guide*.

TMS320C54x EVM PAL Equations

This appendix contains the programmable logic source for the 'C54x EVM PALS. These PAL equations were compiled with DATA I/O ABEL version 4.0 with per-pin autopolarity optimization.

Topic	Page
A.1 Host Decode	A-2
A.2 Host Control Strokes	A-4
A.3 Target Control Strokes	A-6
A.4 Miscellaneous Logic	A-8
A.5 Host Interrupt Logic	A-10
A.6 Target Interrupt Logic	A-14

A.1 Host Decode

```
module Host_Address_Decode

title '
DWG. NAME    TMS320C5xx EVM
ASSY #       D600100-0001
PAL #        U17, 100*
COMPANY      TEXAS INSTRUMENTS INCORPORATED
ENGR         GREG LOREK
DATE         12/21/94'

    u17      device    'P16L8';

    ha0      pin       1;    "inputs
    ha5      pin       2;
    ha6      pin       3;
    ha7      pin       4;
    ha8      pin       5;
    ha9      pin       6;
    ha10     pin       7;
    ha11     pin       8;
    bhe_     pin       9;
    haen_    pin      11;
    mapsel0  pin      13;
    mapsel1  pin      14;

    iol6_    pin      12; "outputs
    usrsel_  pin      16;
    emusel_  pin      17;
    card_    pin      18;

    addr     = [ha11,ha10,ha9,ha8,ha7,ha6,ha5,.x.,.x.,.x.,.x.,.x.];
    map      = [mapsel0,mapsell1];

@radix 16;
equations
!usrsel_ = !haen_ & !bhe_ & !ha0 &
( ((map==0) & (addr >= 0a40) & (addr < 0a60))
# ((map==1) & (addr >= 0a80) & (addr < 0aa0))
# ((map==2) & (addr >= 0b20) & (addr < 0b40))
# ((map==3) & (addr >= 0b40) & (addr < 0b60)) );

!emusel_ = !haen_ & !bhe_ & !ha0 &
( ((map==0) & (addr >= 0240) & (addr < 0260))
# ((map==0) & (addr >= 0640) & (addr < 0660))
# ((map==1) & (addr >= 0280) & (addr < 02a0))
# ((map==1) & (addr >= 0680) & (addr < 06a0))
# ((map==2) & (addr >= 0320) & (addr < 0340))
# ((map==2) & (addr >= 0720) & (addr < 0740))
# ((map==3) & (addr >= 0340) & (addr < 0360))
# ((map==3) & (addr >= 0740) & (addr < 0760)) );

!card_ = !usrsel_ # !emusel_;

iol6_ = 0;
iol6_.oe = !card_;
```



```
test_vectors
([haen_, bhe_, map, addr, ha0] -> [usrsel_, emusel_, card_, io16_])
[ 1 , 0 , 0 , 0a40, 0 ] -> [ 1 , 1 , 1 , .z. ];
[ 0 , 1 , 0 , 0a40, 0 ] -> [ 1 , 1 , 1 , .z. ];
[ 0 , 0 , 0 , 0a41, 1 ] -> [ 1 , 1 , 1 , .z. ];

[ 0 , 0 , 0 , 0a40, 0 ] -> [ 0 , 1 , 0 , 0 ];
[ 0 , 0 , 1 , 0a80, 0 ] -> [ 0 , 1 , 0 , 0 ];
[ 0 , 0 , 2 , 0b20, 0 ] -> [ 0 , 1 , 0 , 0 ];
[ 0 , 0 , 3 , 0b40, 0 ] -> [ 0 , 1 , 0 , 0 ];

[ 0 , 0 , 0 , 0240, 0 ] -> [ 1 , 0 , 0 , 0 ];
[ 0 , 0 , 0 , 0640, 0 ] -> [ 1 , 0 , 0 , 0 ];
[ 0 , 0 , 1 , 0280, 0 ] -> [ 1 , 0 , 0 , 0 ];
[ 0 , 0 , 1 , 0680, 0 ] -> [ 1 , 0 , 0 , 0 ];
[ 0 , 0 , 2 , 0320, 0 ] -> [ 1 , 0 , 0 , 0 ];
[ 0 , 0 , 2 , 0720, 0 ] -> [ 1 , 0 , 0 , 0 ];
[ 0 , 0 , 3 , 0340, 0 ] -> [ 1 , 0 , 0 , 0 ];
[ 0 , 0 , 3 , 0740, 0 ] -> [ 1 , 0 , 0 , 0 ];

end
```

A.2 Host Control Strobes

```
module Host_Control_Strobes

title '
DWG. NAME   TMS320C5xx EVM
ASSY #      D600100-0001
PAL #       U13, 100*
COMPANY     TEXAS INSTRUMENTS INCORPORATED
ENGR        GREG LOREK
DATE        12/21/94'

    u13      device 'P16L8';

    ha1      pin    1;  "inputs
    ha2      pin    2;
    ha3      pin    3;
    ha4      pin    4;
    usrsel_  pin    5;
    iord_    pin    6;
    iowr_    pin    7;
    hreset_  pin    8;

    hard_    pin   12; "outputs
    hawr_    pin   13;
    hbrd_    pin   14;
    hbwr_    pin   15;
    hbwrs_   pin   16;
    hstrd_   pin   17;
    hstwr_   pin   18;
    hstwrs_  pin   19;

    addr = [ha4,ha3,ha2,ha1,.x.];  "shorten for test vectors
    ard = hard_;
    awr = hawr_;
    brd = hbrd_;
    bwr = hbwr_;
    bws = hbwrs_;
    srd = hstrd_;
    swr = hstwr_;
    sws = hstwrs_;

@radix 16;
equations
    !hard_  = !usrsel_ & !iord_ & (addr == 00);
    !hawr_  = !usrsel_ & !iowr_ & (addr == 00);
    !hbrd_  = !usrsel_ & !iord_ & ((addr == 04) # (addr == 06));
    !hbwr_  = !usrsel_ & !iowr_ & ((addr == 04) # (addr == 06));
    !hbwrs_ = !usrsel_ & !iowr_ & (addr == 06);
    !hstrd_ = !usrsel_ & !iord_ & ((addr == 08) # (addr == 0a));
    !hstwr_ = !usrsel_ & !iowr_ & ((addr == 08) # (addr == 0a));
    !hstwrs_ = !usrsel_ & !iowr_ & (addr == 0a) # !hreset_;
```

```
test_vectors
  ([usrsel_,iord_,iowr_,addr,hreset_] -> [ard,awr,brd,bwr,bws,srd,swr,sws])
  [ 1 , 0 , 0 , 0 , 1 ] -> [ 1 , 1 , 1 , 1 , 1 , 1 , 1 , 1 ];
  [ 0 , 1 , 1 , 0 , 1 ] -> [ 1 , 1 , 1 , 1 , 1 , 1 , 1 , 1 ];

  [ 0 , 0 , 1 , 0 , 1 ] -> [ 0 , 1 , 1 , 1 , 1 , 1 , 1 , 1 ];
  [ 0 , 1 , 0 , 0 , 1 ] -> [ 1 , 0 , 1 , 1 , 1 , 1 , 1 , 1 ];
  [ 0 , 0 , 0 , 2 , 1 ] -> [ 1 , 1 , 1 , 1 , 1 , 1 , 1 , 1 ];
  [ 0 , 0 , 1 , 4 , 1 ] -> [ 1 , 1 , 0 , 1 , 1 , 1 , 1 , 1 ];
  [ 0 , 1 , 0 , 4 , 1 ] -> [ 1 , 1 , 1 , 0 , 1 , 1 , 1 , 1 ];
  [ 0 , 0 , 1 , 6 , 1 ] -> [ 1 , 1 , 0 , 1 , 1 , 1 , 1 , 1 ];
  [ 0 , 1 , 0 , 6 , 1 ] -> [ 1 , 1 , 1 , 0 , 0 , 1 , 1 , 1 ];
  [ 0 , 0 , 1 , 8 , 1 ] -> [ 1 , 1 , 1 , 1 , 1 , 1 , 0 , 1 ];
  [ 0 , 1 , 0 , 8 , 1 ] -> [ 1 , 1 , 1 , 1 , 1 , 1 , 1 , 0 ];
  [ 0 , 0 , 1 , 0a , 1 ] -> [ 1 , 1 , 1 , 1 , 1 , 1 , 0 , 1 ];
  [ 0 , 1 , 0 , 0a , 1 ] -> [ 1 , 1 , 1 , 1 , 1 , 1 , 1 , 0 ];
  [ 1 , 1 , 1 , 0 , 0 ] -> [ 1 , 1 , 1 , 1 , 1 , 1 , 1 , 0 ];

end
```

A.3 Target Control Strokes

```
module Target_Control_Strokes

title '
DWG. NAME   TMS320C5xx EVM
ASSY #      D600100-0001
PAL #       U19, 100*
COMPANY     TEXAS INSTRUMENTS INCORPORATED
ENGR        GREG LOREK
DATE        12/21/94'

    u19      device 'P16L8';

    ta0      pin    1;  "inputs
    ta1      pin    2;
    ta2      pin    3;
    ta3      pin    4;
    ta4      pin    5;
    iostb_   pin    6;
    is_      pin    7;
    rw_      pin    8;

    tard     pin    12; "outputs
    tawr_    pin    13;
    tawrs_   pin    14;
    tbrd_    pin    15;
    tbwr_    pin    16;
    tbwrs_   pin    17;
    tstrd_   pin    18;
    tstwr_   pin    19;

    addr = [ta4,ta3,ta2,ta1,ta0];  "shorten names for test vectors
    ard = tard;
    awr = tawr_;
    aws = tawrs_;
    brd = tbrd_;
    bwr = tbwr_;
    bws = tbwrs_;
    srd = tstrd_;
    swr = tstwr_;

@radix 16;
equations
    tard = !iostb_ & rw_ & ((addr == 10) # (addr == 11));
    !tawr_ = !iostb_ & !rw_ & ((addr == 10) # (addr == 11));
    !tawrs_ = !iostb_ & !rw_ & ( (addr == 11));
    !tbrd_ = !iostb_ & rw_ & ((addr == 12) # (addr == 13));
    !tbwr_ = !iostb_ & !rw_ & ((addr == 12) # (addr == 13));
    !tbwrs_ = !iostb_ & !rw_ & ( (addr == 13));
    !tstrd_ = !iostb_ & rw_ & ((addr == 14));
    !tstwr_ = !iostb_ & !rw_ & ((addr == 14));
```

```
test_vectors
  ([iostb_,rw_, addr] -> [ard,awr,aws,brd,bwr,bws,srd,swr])
  [ 1 ,.x., .x.] -> [ 0 , 1 , 1 , 1 , 1 , 1 , 1 , 1 ];
  [ 0 , 1 , 10 ] -> [ 1 , 1 , 1 , 1 , 1 , 1 , 1 , 1 ];
  [ 0 , 1 , 11 ] -> [ 1 , 1 , 1 , 1 , 1 , 1 , 1 , 1 ];
  [ 0 , 0 , 10 ] -> [ 0 , 0 , 1 , 1 , 1 , 1 , 1 , 1 ];
  [ 0 , 0 , 11 ] -> [ 0 , 0 , 0 , 1 , 1 , 1 , 1 , 1 ];
  [ 0 , 1 , 12 ] -> [ 0 , 1 , 1 , 0 , 1 , 1 , 1 , 1 ];
  [ 0 , 1 , 13 ] -> [ 0 , 1 , 1 , 0 , 1 , 1 , 1 , 1 ];
  [ 0 , 0 , 12 ] -> [ 0 , 1 , 1 , 1 , 0 , 1 , 1 , 1 ];
  [ 0 , 0 , 13 ] -> [ 0 , 1 , 1 , 1 , 0 , 0 , 1 , 1 ];
  [ 0 , 1 , 14 ] -> [ 0 , 1 , 1 , 1 , 1 , 1 , 0 , 1 ];
  [ 0 , 0 , 14 ] -> [ 0 , 1 , 1 , 1 , 1 , 1 , 1 , 0 ];
end
```

A.4 Miscellaneous Logic

```
module Misc_Logic

title '
DWG. NAME   TMS320C5xx EVM
ASSY #      D600100-0001
PAL #       U22, 100*
COMPANY     TEXAS INSTRUMENTS INCORPORATED
ENGR        GREG LOREK
DATE        12/21/94'

    u22      device 'P16L8';

    iord_    pin    1;  "inputs
    iowr_    pin    2;
    emusel_  pin    3;
    card_    pin    4;
    tbcevt3  pin    5;
    x1bio_   pin    6;
    hbio_    pin    7;
    x2bio_   pin    8;
    hreset   pin    9;

    tbcrd_   pin    12; "outputs
    tbcwr_   pin    13;
    dira     pin    14;
    dirb_    pin    15;
    ttrst_   pin    16;
    bio_     pin    17;
    hreset_  pin    19;

equations
    !tbcrd_ = !iord_ & !emusel_;
    !tbcwr_ = !iowr_ & !emusel_;
    dira    = !iord_ & !card_;
    !dirb_  = !iowr_ & !card_ # card_;

    !ttrst_ = tbcevt3;
    !bio_   = !x1bio_ # !x2bio_ # !hbio_;
    hreset_ = !hreset;
```

```
test_vectors
  ([iord_,iowr_,emusel_,card_] -> [tbcrd_,tbcwr_,dira,dirb_])
  [ 1 , 1 , 1 , 1 ] -> [ 1 , 1 , 0 , 0 ];
  [ 0 , 1 , 1 , 1 ] -> [ 1 , 1 , 0 , 0 ];
  [ 1 , 0 , 1 , 1 ] -> [ 1 , 1 , 0 , 0 ];

  [ 1 , 1 , 1 , 0 ] -> [ 1 , 1 , 0 , 1 ];
  [ 0 , 1 , 1 , 0 ] -> [ 1 , 1 , 1 , 1 ];
  [ 1 , 0 , 1 , 0 ] -> [ 1 , 1 , 0 , 0 ];

  [ 1 , 1 , 0 , 0 ] -> [ 1 , 1 , 0 , 1 ];
  [ 0 , 1 , 0 , 0 ] -> [ 0 , 1 , 1 , 1 ];
  [ 1 , 0 , 0 , 0 ] -> [ 1 , 0 , 0 , 0 ];

test_vectors
  ([tbcevt3] -> [ttrst_])
  [ 1 ] -> [ 0 ];
  [ 0 ] -> [ 1 ];

test_vectors
  ([x1bio_,x2bio_,hbio_] -> [bio_])
  [ 1 , 1 , 1 ] -> [ 1 ];
  [ 0 , 1 , 1 ] -> [ 0 ];
  [ 1 , 0 , 1 ] -> [ 0 ];
  [ 1 , 1 , 0 ] -> [ 0 ];

test_vectors
  ([hreset] -> [hreset_])
  [ 1 ] -> [ 0 ];
  [ 0 ] -> [ 1 ];

end
```

A.5 Host Interrupt Logic

```
module Host_Interrupt

title '
DWG. NAME   TMS320C5xx EVM
ASSY #      D600100-0001
PAL #       U18, 100*
COMPANY     TEXAS INSTRUMENTS INCORPORATED
ENGR        GREG LOREK
DATE        12/21/94'

    u18      device 'P16R4';

    clk      pin    1;      "inputs
    atie     pin    2;
    btie     pin    3;
    tard     pin    4;
    tawr_    pin    5;
    tawrs_   pin    6;
    tbwrs_   pin    7;
    hard_    pin    8;
    hbrd_    pin    9;
    oe_      pin   11;
    hstwrs_  pin   12;
    thfull_  pin   13;

    q0       pin   14;      "outputs
    harst    pin   15;
    q2       pin   16;
    hintq    pin   17;
    hint     pin   18;
    tardf_   pin   19;

    flag_clear = ^b00;    "states
    write      = ^b01;
    flag_set   = ^b11;
    read       = ^b10;

    idle       = ^b00;
    aint       = ^b01;
    wait       = ^b11;
    bint       = ^b10;

equations
    [q0,harst,q2,hintq].c = clk;
    [q0,harst,q2,hintq].oe = !oe_;

    !tardf_ = tard # !hstwrs_;

test_vectors
    ([tard, hstwrs_] -> [tardf_])
    [ 1 , 0 ] -> [ 0 ]; "1
    [ 1 , 1 ] -> [ 0 ];
    [ 0 , 0 ] -> [ 0 ];
    [ 0 , 1 ] -> [ 1 ];
```



```

state_diagram [harst,q0]
  State flag_clear:
    if (!hstwr_) then goto flag_clear else
    if (!tawr_) then goto write
      else goto flag_clear;

  State write:
    if (!hstwr_) then goto flag_clear else
    if (!tawr_) then goto write
      else goto flag_set;

  State flag_set:
    if (!hstwr_) then goto flag_clear else
    if (!hard_) then goto read
      else goto flag_set;

  State read:
    if (!hstwr_) then goto flag_clear else
    if (!hard_) then goto read
      else goto flag_clear;

test_vectors
  ([clk,oe_,hstwr_,tawr_,hard_] -> [harst,q0])
  [.c., 0 , 0 , 1 , 1 ] -> flag_clear;          "5
  [.c., 0 , 1 , 1 , 1 ] -> flag_clear;
  [.c., 0 , 1 , 0 , 1 ] -> write;
  [.c., 0 , 1 , 0 , 1 ] -> write;
  [.c., 0 , 1 , 1 , 1 ] -> flag_set;
  [.c., 0 , 1 , 1 , 1 ] -> flag_set;
  [.c., 0 , 1 , 1 , 0 ] -> read;
  [.c., 0 , 1 , 1 , 0 ] -> read;
  [.c., 0 , 1 , 1 , 1 ] -> flag_clear;

  [.c., 0 , 0 , 0 , 1 ] -> flag_clear;          "14
  [.c., 0 , 1 , 1 , 1 ] -> flag_clear;
  [.c., 0 , 1 , 0 , 1 ] -> write;
  [.c., 0 , 0 , 0 , 1 ] -> flag_clear;
  [.c., 0 , 0 , 0 , 1 ] -> flag_clear;

  [.c., 0 , 1 , 0 , 1 ] -> write;              "19
  [.c., 0 , 1 , 1 , 1 ] -> flag_set;
  [.c., 0 , 1 , 1 , 1 ] -> flag_set;
  [.c., 0 , 0 , 1 , 0 ] -> flag_clear;

  [.c., 0 , 1 , 0 , 1 ] -> write;              "23
  [.c., 0 , 1 , 1 , 1 ] -> flag_set;
  [.c., 0 , 0 , 1 , 1 ] -> flag_clear;

  [.c., 0 , 1 , 0 , 1 ] -> write;              "26
  [.c., 0 , 1 , 0 , 1 ] -> write;
  [.c., 0 , 1 , 1 , 1 ] -> flag_set;
  [.c., 0 , 1 , 1 , 1 ] -> flag_set;
  [.c., 0 , 1 , 1 , 0 ] -> read;
  [.c., 0 , 0 , 1 , 0 ] -> flag_clear;

```

Host Interrupt Logic

```
state_diagram [hintq,q2]
  State idle:
    hint.oe = 1;
    hint = 0;
    if (!hstwrs_) then goto idle else
    if (atie & !tawr_ # !tawrs_) then goto aint else
    if (btie & (!tbwrs_ # !thfull_)) then goto bint else
    goto idle;

  State aint:
    hint.oe = 0;
    hint = 1;
    if (!hstwrs_) then goto wait else
    if (!hard_) then goto wait else
    goto aint;

  State bint:
    hint.oe = 0;
    hint = 1;
    if (!hstwrs_) then goto wait else
    if (!hbrd_) then goto wait else
    goto bint;

  State wait:
    hint.oe = 0;
    hint = 1;
    if (!hstwrs_) then goto wait else
    if (!hard_ # !hbrd_) then goto wait else
    if ( (atie # btie) & !(btie & !thfull_) ) then goto idle else
    goto wait
```

```

test_vectors
  ([clk,oe_,hstwr_,atie,tawr_,tawrs_,hard_,hbrd_] -> [[hintq,q2],hint])
  [.c., 0 , 0 , 1 , 1 , 1 , 1 , 1 ] -> [.x.,.x.];      "32
  [.c., 0 , 1 , 1 , 1 , 1 , 1 , 1 ] -> [idle, 0 ];

  [.c., 0 , 0 , 1 , 1 , 1 , 1 , 1 ] -> [idle, 0 ];
  [.c., 0 , 1 , 0 , 1 , 0 , 0 , 1 ] -> [aint,.z.];
  [.c., 0 , 1 , 0 , 1 , 1 , 1 , 1 ] -> [aint,.z.];
  [.c., 0 , 1 , 0 , 1 , 1 , 0 , 1 ] -> [wait,.z.];
  [.c., 0 , 1 , 0 , 1 , 1 , 0 , 1 ] -> [wait,.z.];
  [.c., 0 , 1 , 0 , 1 , 1 , 1 , 0 ] -> [wait,.z.];
  [.c., 0 , 1 , 1 , 1 , 1 , 1 , 1 ] -> [idle, 0 ];

  [.c., 0 , 1 , 0 , 0 , 1 , 1 , 1 ] -> [idle, 0 ];      "41
  [.c., 0 , 1 , 1 , 0 , 1 , 0 , 1 ] -> [aint,.z.];
  [.c., 0 , 1 , 1 , 0 , 1 , 1 , 1 ] -> [aint,.z.];
  [.c., 0 , 1 , 1 , 1 , 1 , 0 , 1 ] -> [wait,.z.];
  [.c., 0 , 1 , 1 , 1 , 1 , 1 , 1 ] -> [idle, 0 ];

  [.c., 0 , 1 , 1 , 0 , 1 , 1 , 1 ] -> [aint,.z.];
  [.c., 0 , 0 , 1 , 1 , 1 , 1 , 1 ] -> [wait,.z.];
  [.c., 0 , 0 , 1 , 1 , 1 , 1 , 1 ] -> [wait,.z.];
  [.c., 0 , 1 , 1 , 1 , 1 , 1 , 1 ] -> [idle, 0 ];

test_vectors
  ([clk,oe_,hstwr_,btie,tbwr_,thfull_,tawrs_,hard_,hbrd_] -> [[hintq,q2],hint])
  [.c., 0 , 1 , 0 , 1 , 1 , 1 , 1 , 1 ] -> [idle, 0 ];      "50
  [.c., 0 , 1 , 1 , 0 , 1 , 1 , 1 , 1 ] -> [bint,.z.];
  [.c., 0 , 1 , 1 , 1 , 1 , 1 , 1 , 1 ] -> [bint,.z.];
  [.c., 0 , 1 , 1 , 1 , 1 , 1 , 1 , 0 ] -> [wait,.z.];
  [.c., 0 , 1 , 1 , 1 , 1 , 1 , 1 , 0 ] -> [wait,.z.];
  [.c., 0 , 1 , 1 , 1 , 1 , 1 , 1 , 1 ] -> [idle, 0 ];

  [.c., 0 , 1 , 0 , 1 , 0 , 1 , 1 , 1 ] -> [idle, 0 ];      "56
  [.c., 0 , 1 , 1 , 1 , 0 , 1 , 1 , 1 ] -> [bint,.z.];
  [.c., 0 , 0 , 1 , 1 , 1 , 1 , 1 , 1 ] -> [wait,.z.];
  [.c., 0 , 0 , 1 , 1 , 1 , 1 , 1 , 1 ] -> [wait,.z.];
  [.c., 0 , 1 , 1 , 1 , 0 , 1 , 1 , 0 ] -> [wait,.z.];
  [.c., 0 , 1 , 1 , 1 , 0 , 1 , 1 , 1 ] -> [wait,.z.];
  [.c., 0 , 1 , 1 , 1 , 1 , 1 , 1 , 1 ] -> [idle, 0 ];

end

```

A.6 Target Interrupt Logic

```
module Target_Interrupt

title '
DWG. NAME   TMS320C5xx EVM
ASSY #     D600100-0001
PAL #      U14, 100*
COMPANY    TEXAS INSTRUMENTS INCORPORATED
ENGR       GREG LOREK
DATE      12/21/94'

    u14      device 'P16R4';

    clk      pin      1;      "inputs
    tbwrs_   pin      2;
    hbrd_    pin      3;
    hstwrs_  pin      4;
    hbwrs_   pin      5;
    tbrd_    pin      6;
    htfull_  pin      7;
    htepty_  pin      8;
    thfull_  pin      9;
    oe_      pin     11;
    thepty_  pin     12;

    int2_    pin     14;      "outputs
    q1       pin     15;
    q2       pin     16;
    hbrst2   pin     17;

    hbxst0   pin     18;
    tbxst0   pin     19;

    idle     =    ^b11;      "states
    write    =    ^b01;
    int      =    ^b00;
    full     =    ^b10;

    flag_clear = ^b00;
    flag_set   = ^b01;
    wait      = ^b11;
    read      = ^b10;

equations
    [int2_,q1,q2,hbrst2].c = clk;
    [int2_,q1,q2,hbrst2].oe = !oe_;

    tbxst0 = thfull_ & thepty_;
    hbxst0 = htfull_ & htepty_;

test_vectors
    ([thfull_,thepty_] -> [tbxst0])
    [ 1 , 1 ] -> [ 1 ];      "1
    [ 0 , 1 ] -> [ 0 ];
    [ 1 , 0 ] -> [ 0 ];
    [ 0 , 0 ] -> [ 0 ];
```

```

test_vectors
  ([htfull_,htepty_] -> [hbxst0])
  [ 1 , 1 ] -> [ 1 ];      "5
  [ 0 , 1 ] -> [ 0 ];
  [ 1 , 0 ] -> [ 0 ];
  [ 0 , 0 ] -> [ 0 ];

state_diagram [hbrst2,q2]
  State flag_clear:
    if (!hstwrs_) then goto flag_clear else
    if (!tbwrs_) then goto flag_set else
    goto flag_clear;

  State flag_set:
    if (!hstwrs_) then goto flag_clear else
    if (!tbwrs_) then goto flag_set else
    if ( hbrd_) then goto wait else
    goto flag_set;

  State wait:
    if (!hstwrs_) then goto flag_clear else
    if (!hbrd_) then goto read else
    goto wait;

  State read:
    if (!hstwrs_) then goto flag_clear else
    if (!hbrd_) then goto read else
    goto flag_clear;

test_vectors
  ([clk,oe_,hstwrs_,tbwrs_,hbrd_] -> [hbrst2,q2])
  [.c., 0 , 0 , 1 , 1 ] -> flag_clear; "9
  [.c., 0 , 1 , 1 , 1 ] -> flag_clear;
  [.c., 0 , 1 , 0 , 1 ] -> flag_set;
  [.c., 0 , 1 , 0 , 1 ] -> flag_set;
  [.c., 0 , 1 , 1 , 0 ] -> flag_set;
  [.c., 0 , 1 , 1 , 1 ] -> wait;
  [.c., 0 , 1 , 1 , 1 ] -> wait;
  [.c., 0 , 1 , 1 , 0 ] -> read;
  [.c., 0 , 1 , 1 , 0 ] -> read;
  [.c., 0 , 1 , 1 , 1 ] -> flag_clear;

  [.c., 0 , 1 , 0 , 1 ] -> flag_set; "19
  [.c., 0 , 0 , 0 , 1 ] -> flag_clear;

  [.c., 0 , 1 , 0 , 1 ] -> flag_set;
  [.c., 0 , 1 , 1 , 1 ] -> wait;
  [.c., 0 , 0 , 0 , 1 ] -> flag_clear;

  [.c., 0 , 1 , 0 , 1 ] -> flag_set;
  [.c., 0 , 1 , 1 , 1 ] -> wait;
  [.c., 0 , 0 , 0 , 0 ] -> flag_clear;

  [.c., 0 , 1 , 0 , 1 ] -> flag_set;
  [.c., 0 , 1 , 1 , 1 ] -> wait;
  [.c., 0 , 1 , 1 , 0 ] -> read;
  [.c., 0 , 0 , 1 , 0 ] -> flag_clear;

```

Target Interrupt Logic

```
state_diagram [q1,int2_]
  State idle:
    if (!hstwrs_) then goto idle else
    if (!htfull_) then goto full else
    if (!hbwrs_) then goto write else
    goto idle;

  State write:
    if (!hstwrs_) then goto idle else
    if (!hbwrs_) then goto write else
    goto int;

  State int:
    if (!hstwrs_) then goto idle else
    if (!htfull_) then goto full else
    if (!tbrd_) then goto idle else
    goto int;

  State full:
    if (!htfull_) then goto full else
    if (!hstwrs_) then goto idle else      !hstwrs_ => htfull_
    goto idle;

test_vectors
  ([clk,oe_,hstwrs_,htfull_,hbwrs_,tbrd_] -> [q1,int2_])
  [.c., 0 , 0 , 1 , 1 , 1 ] -> idle;      "31
  [.c., 0 , 1 , 1 , 1 , 1 ] -> idle;
  [.c., 0 , 1 , 1 , 0 , 1 ] -> write;
  [.c., 0 , 1 , 1 , 0 , 1 ] -> write;
  [.c., 0 , 1 , 1 , 1 , 1 ] -> int;
  [.c., 0 , 1 , 1 , 1 , 1 ] -> int;
  [.c., 0 , 1 , 1 , 1 , 0 ] -> idle;

  [.c., 0 , 1 , 1 , 0 , 1 ] -> write;     "38
  [.c., 0 , 1 , 1 , 1 , 0 ] -> int;
  [.c., 0 , 1 , 0 , 1 , 0 ] -> full;
  [.c., 0 , 1 , 0 , 1 , 1 ] -> full;
  [.c., 0 , 1 , 1 , 1 , 1 ] -> idle;

  [.c., 0 , 1 , 0 , 1 , 1 ] -> full;     "43
  [.c., 0 , 1 , 1 , 1 , 1 ] -> idle;

  [.c., 0 , 1 , 1 , 0 , 1 ] -> write;
  [.c., 0 , 1 , 1 , 1 , 0 ] -> int;
  [.c., 0 , 0 , 1 , 1 , 1 ] -> idle;

  [.c., 0 , 1 , 1 , 0 , 1 ] -> write;
  [.c., 0 , 0 , 1 , 1 , 1 ] -> idle;

  [.c., 0 , 1 , 0 , 1 , 1 ] -> full;     "50
  [.c., 0 , 0 , 0 , 1 , 1 ] -> full;
  [.c., 0 , 0 , 1 , 1 , 1 ] -> idle;

end
```

TMS320C54x EVM Schematics

This appendix contains the schematics for the TMS320C54x EVM.

REVISIONS			
REV	DESCRIPTION	DATE	APPROVED
A	ECN563502(E) M. DAWKINS 6-23-95	8-31-95	J. CLARK
B	ECN563626(E) M. DAWKINS 8-31-95		J. CLARK
FORMAL RELEASE			

NOTES, UNLESS OTHERWISE SPECIFIED:

1. RESISTANCE VALUES ARE IN OHMS.
2. CAPACITANCE VALUES ARE IN MICROFARADS.
3. HIGHEST REFERENCE DESIGNATOR USED:
 - A. CAPACITORS C51
 - B. RESISTORS R54
 - C. INDUCTORS L2
 - D. DIODES D2
 - E. IC'S U29
 - F. CONNECTORS J5
 - G. JUMPERS JP3
 - H. SWITCHES S1

4. SWITCH S1 SELECTION

	1	2	I/O BASE ADDRESS SELECTED
ON	ON	OFF	0x0240-0x025F
OFF	OFF	ON	0x0280-0x029F
OFF	ON	OFF	0x0320-0x033F
OFF	OFF	OFF	0x0340-0x035F

5. JP1 SELECTS HOST INTERRUPT SIGNAL

- 1-2 SELECTS INTERRUPT IRQ5
- 3-4 SELECTS INTERRUPT IRQ7
- 5-6 SELECTS INTERRUPT IRQ10
- 7-8 SELECTS INTERRUPT IRQ11

6. JP2 DETERMINES MAJOR HARDWARE REVISIONS.

SEE ASSEMBLY DRAWINGS FOR REVISION INFORMATION.

7. JP3 SELECTS AIC OUTPUT MODE

- 1-2 SELECTS 8 OHM SPEAKER COMPATIBLE SIGNAL
- 2-3 SELECTS 600 OHM LINE COMPATIBLE SIGNAL

8. R11, R12, R13, R14, R15, AND R16 SELECT CLOCK MODE. INSTALL ONLY R11, R14 AND R16 FOR 40 MIPS OPERATION.

REVISION STATUS OF SHEETS		DWN	G. LOREK	DATE
REV		CHK	M. DAWKINS	3-3-95
SH		ENGR	G. LOREK	DATE
REV	* B * A * A	ENGR-MGR	T. COOMES	DATE
SH	8 9 10 11 12 13	QA	J. J. NAMEZ	DATE
REV	B A B * * B A	MFG	M. JACKSON	DATE
SH	1 2 3 4 5 6 7	RLSE	J. CLARK	DATE
		APPLICATION USED ON NEXT ASSY		
		TMS320C54x EVM		
		Size Document Number		
		A D600102		
		Title		
		TEXAS INSTRUMENTS		
		SOFTWARE DEVELOPMENT SYSTEMS		
		SEMICONDUCTOR GROUP		
		HOUSTON, TEXAS		
		Date: September 1, 1995		
		Sheet 1 of 13		

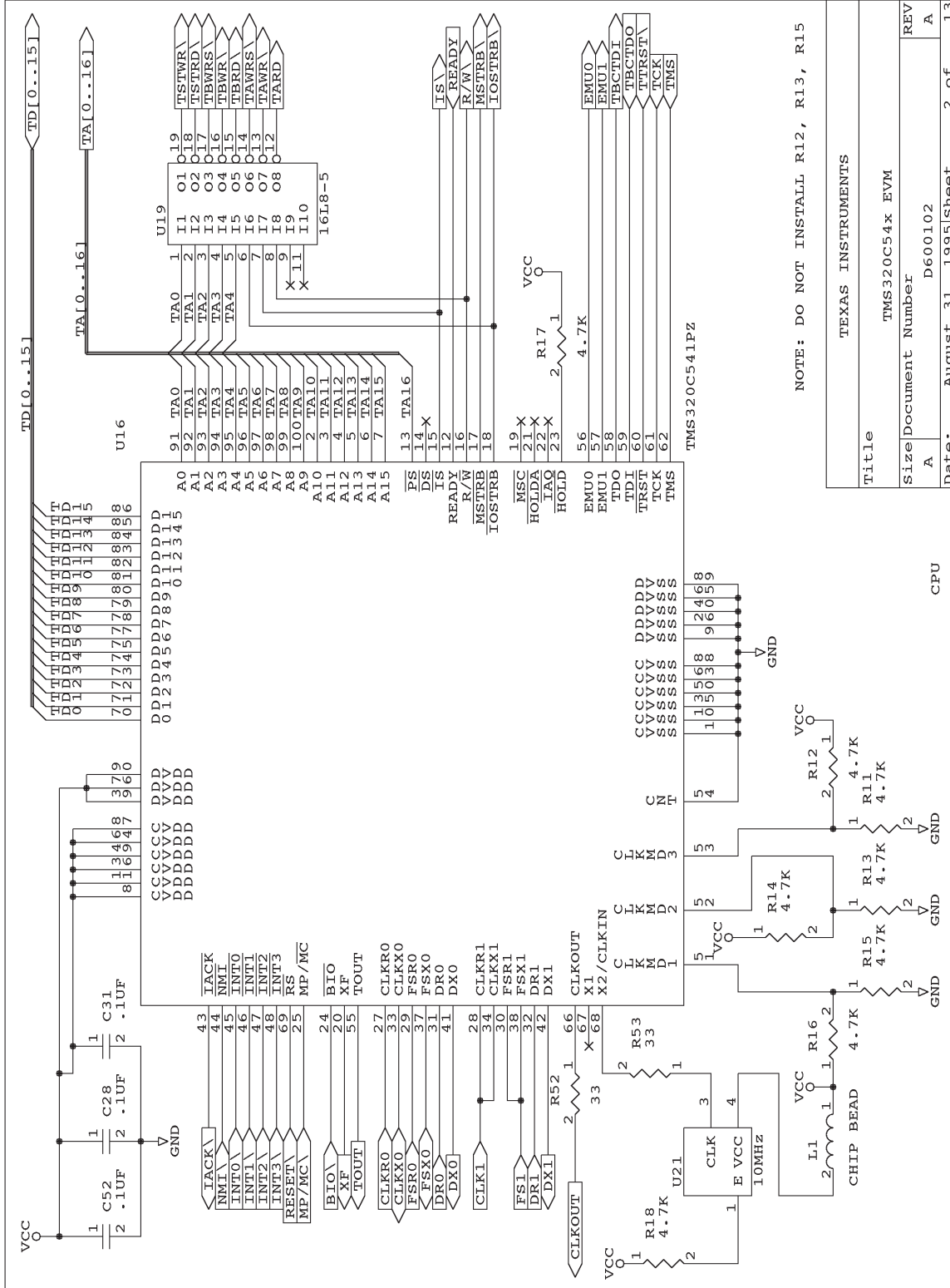

NOTE: DO NOT INSTALL R12, R13, R15

TEXAS INSTRUMENTS	
Title	TMS320C54x EVM
Size Document Number	D600102
REV	A
Date:	August 31, 1995
Sheet	2 of 13

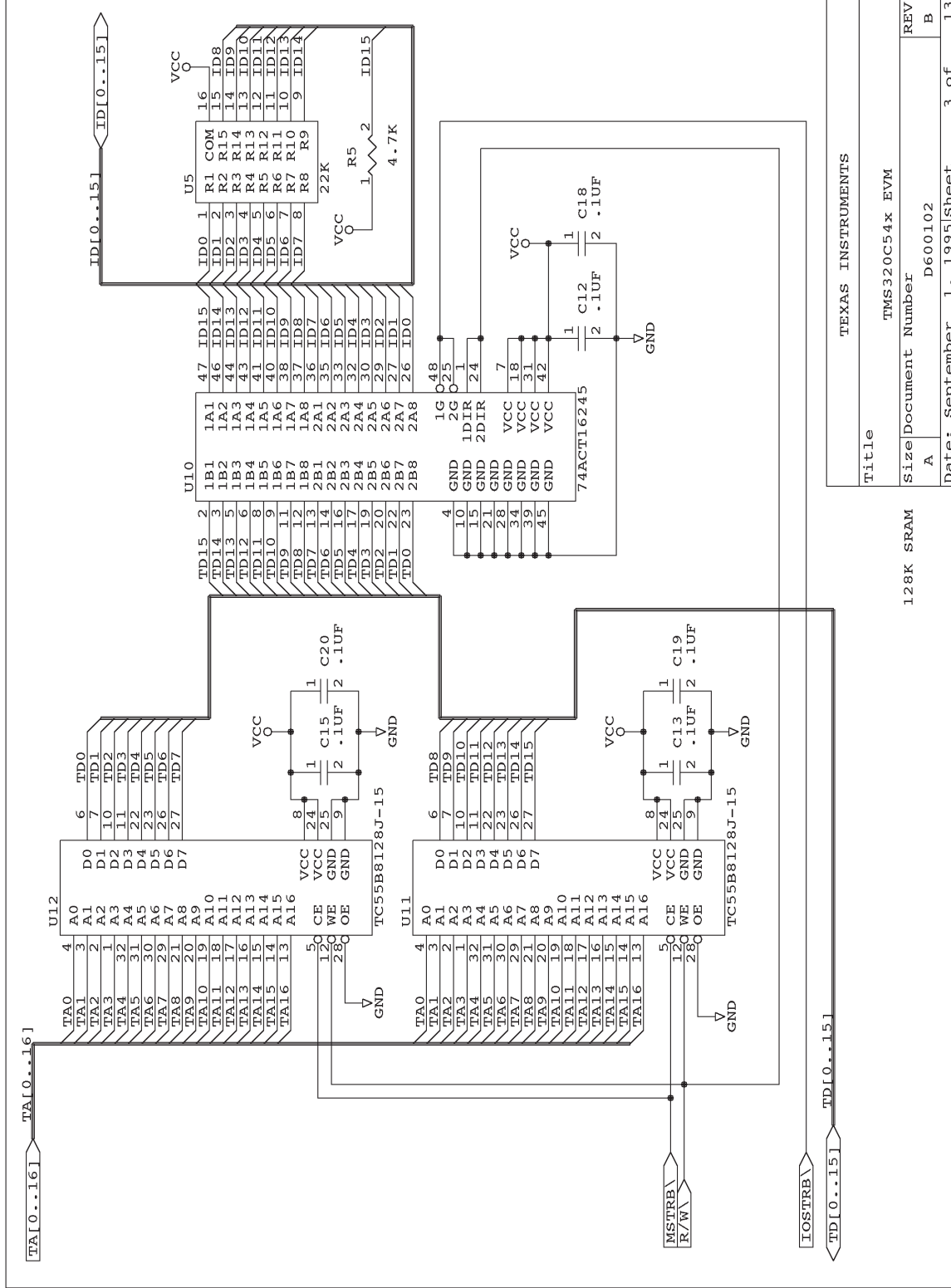

TEXAS INSTRUMENTS	
Title	
TMS320C54x EVM	
Size	Document Number
A	D600102
Date:	September 1, 1995
Sheet	3 of 13

128K SRAM	
Title	
TMS320C54x EVM	
Size	Document Number
A	D600102
Date:	September 1, 1995
Sheet	3 of 13

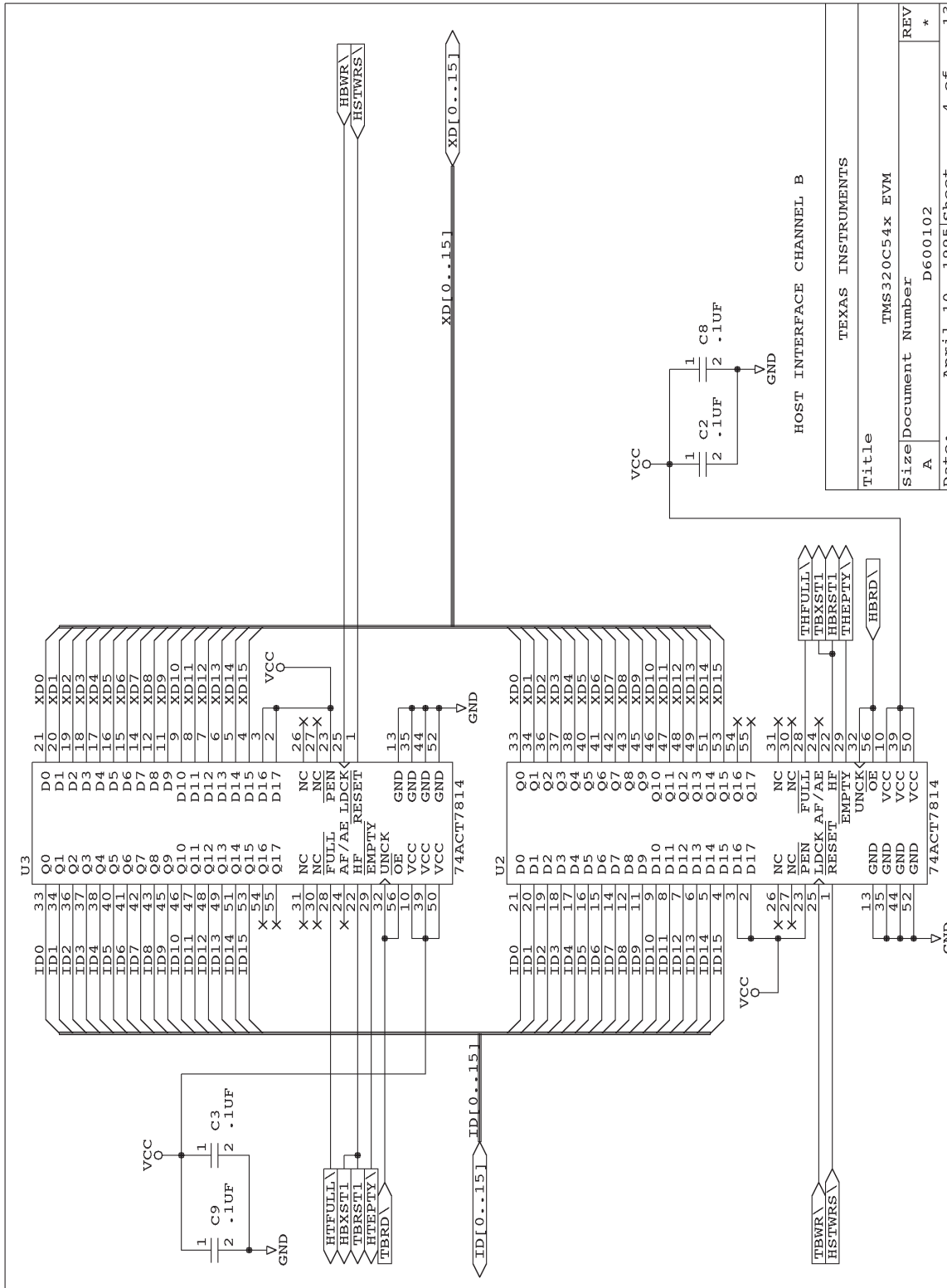

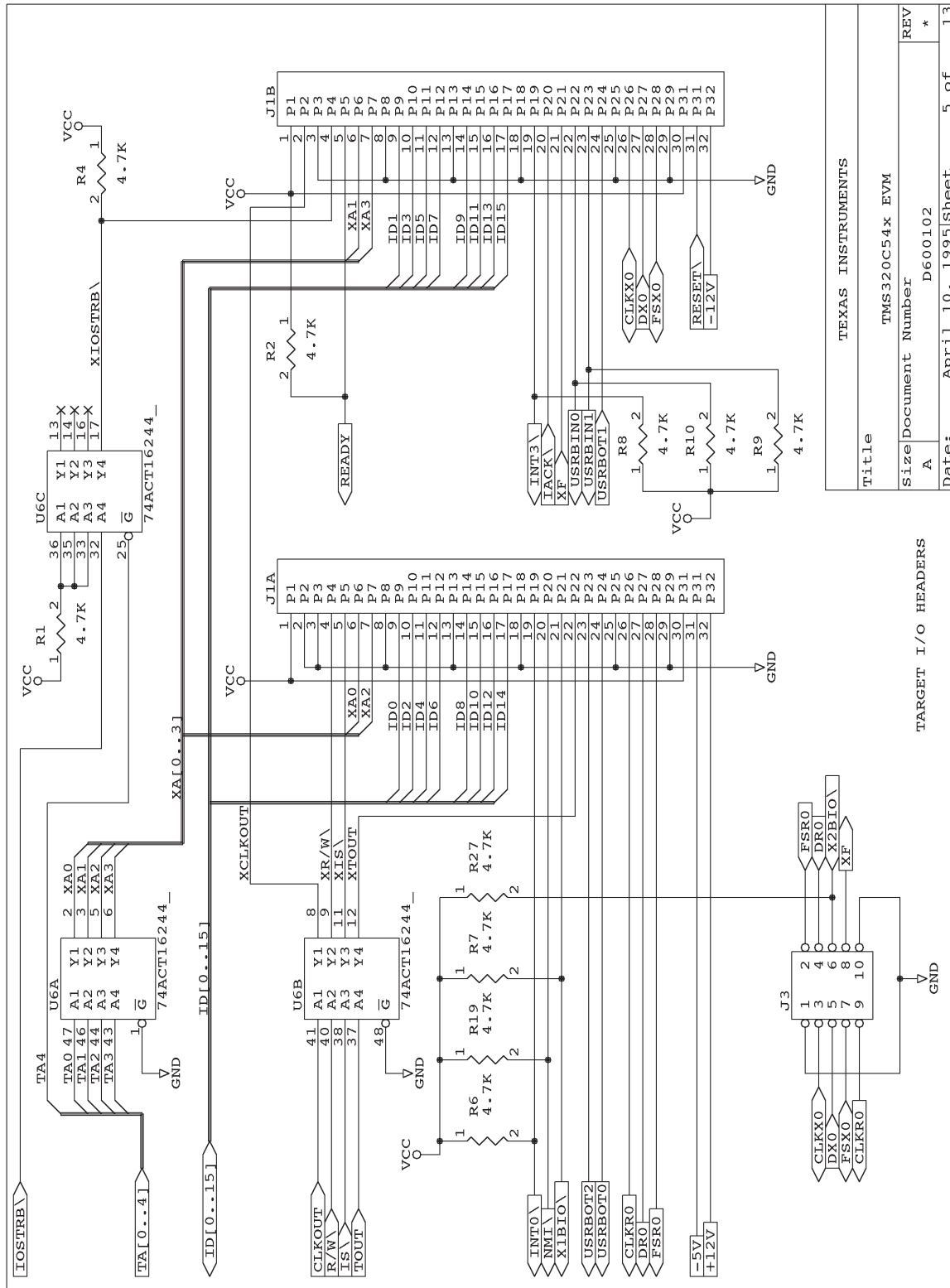

TEXAS INSTRUMENTS	
TMS320C54x EVM	
Title	
Size	Document Number
A	D600102
REV	*
Date:	April 10, 1995
Sheet	5 of 13

TARGET I/O HEADERS

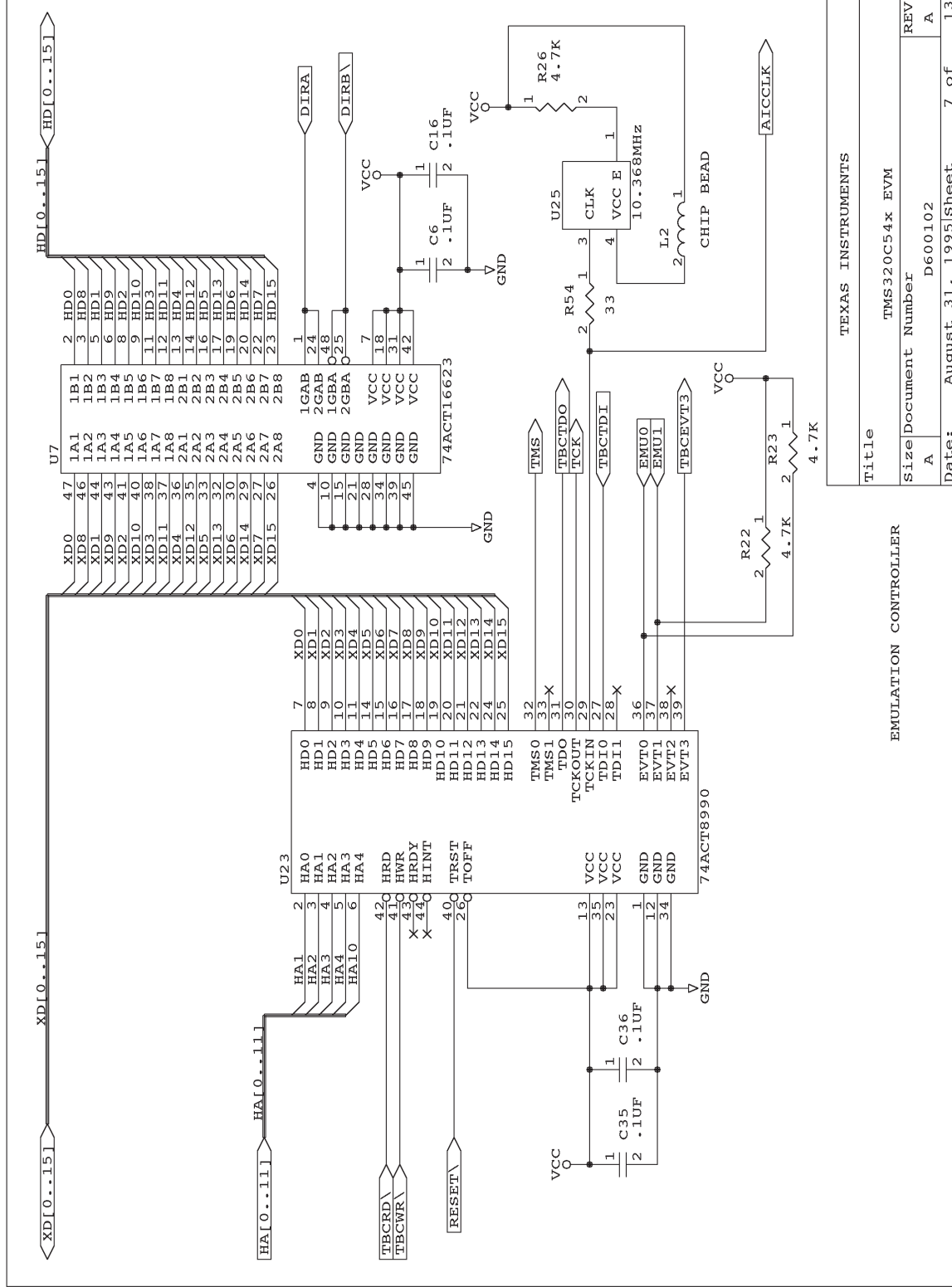

TEXAS INSTRUMENTS	
Title	
TMS320C54x EVM	
Size	Document Number
A	D600102
REV	A
Date:	August 31, 1995
Sheet	7 of 13

EMULATION CONTROLLER	
Title	
TMS320C54x EVM	
Size	Document Number
A	D600102
REV	A
Date:	August 31, 1995
Sheet	7 of 13

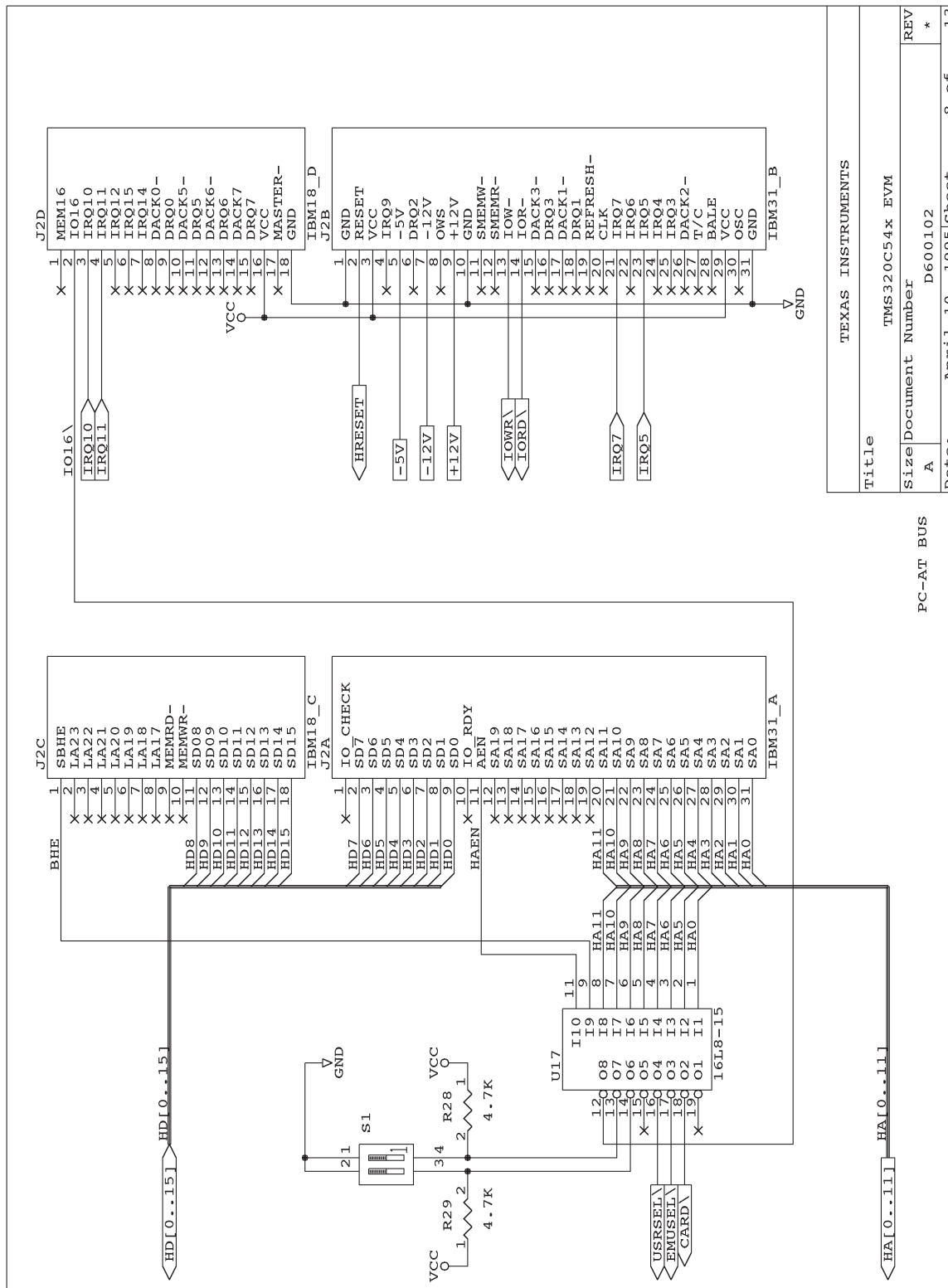

Title		TEXAS INSTRUMENTS	
Size Document Number		TMS320C54x EVM	
A	D600102	REV	*
Date:	April 10, 1995	Sheet	8 of 13

PC-AT BUS

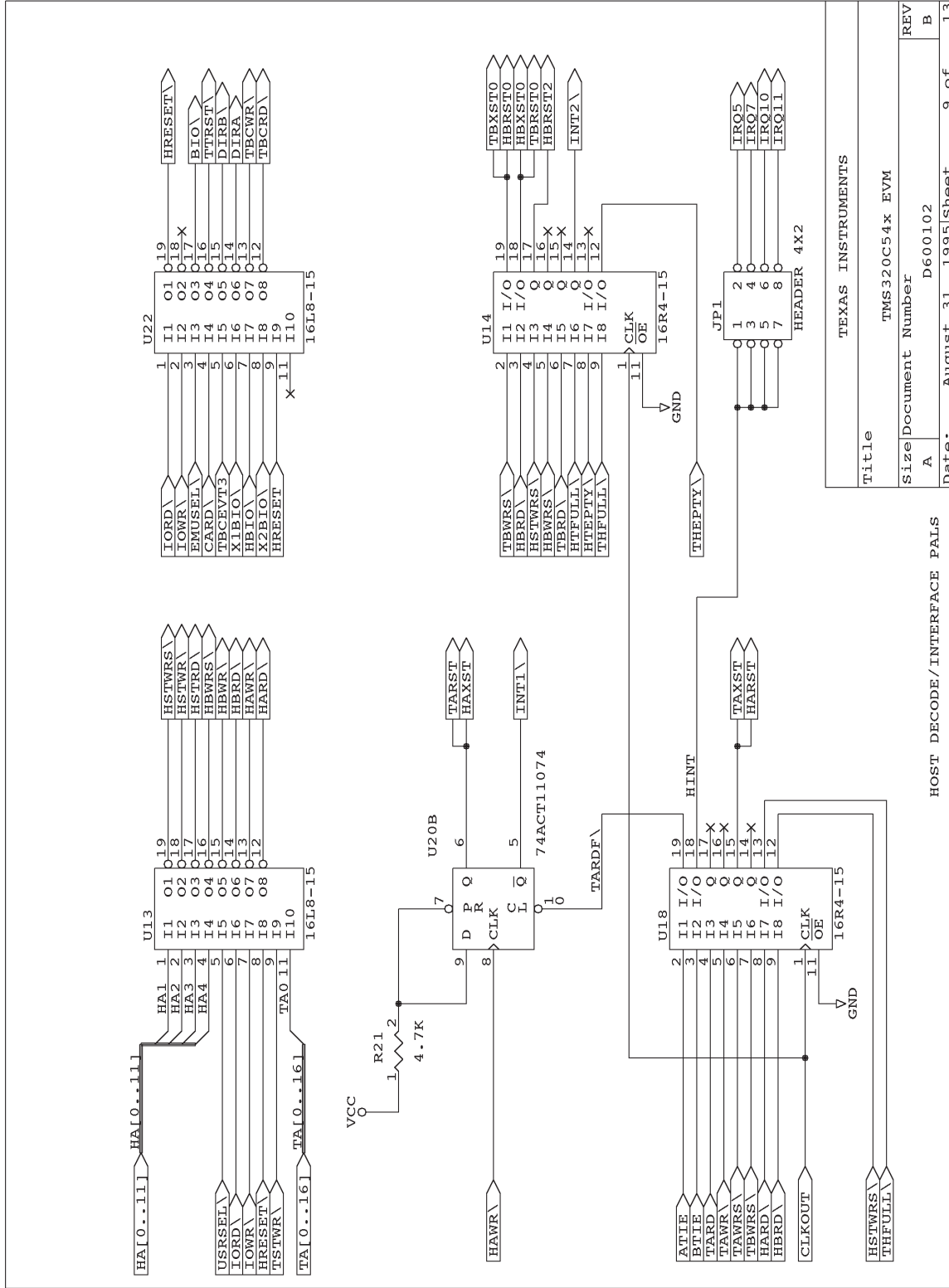

Title		TEXAS INSTRUMENTS	
Size		TMS320C54x EVM	
Document Number		D600102	
REV	A	Sheet	9 of 13

Title		TEXAS INSTRUMENTS	
Size		TMS320C54x EVM	
Document Number		D600102	
REV	A	Sheet	9 of 13

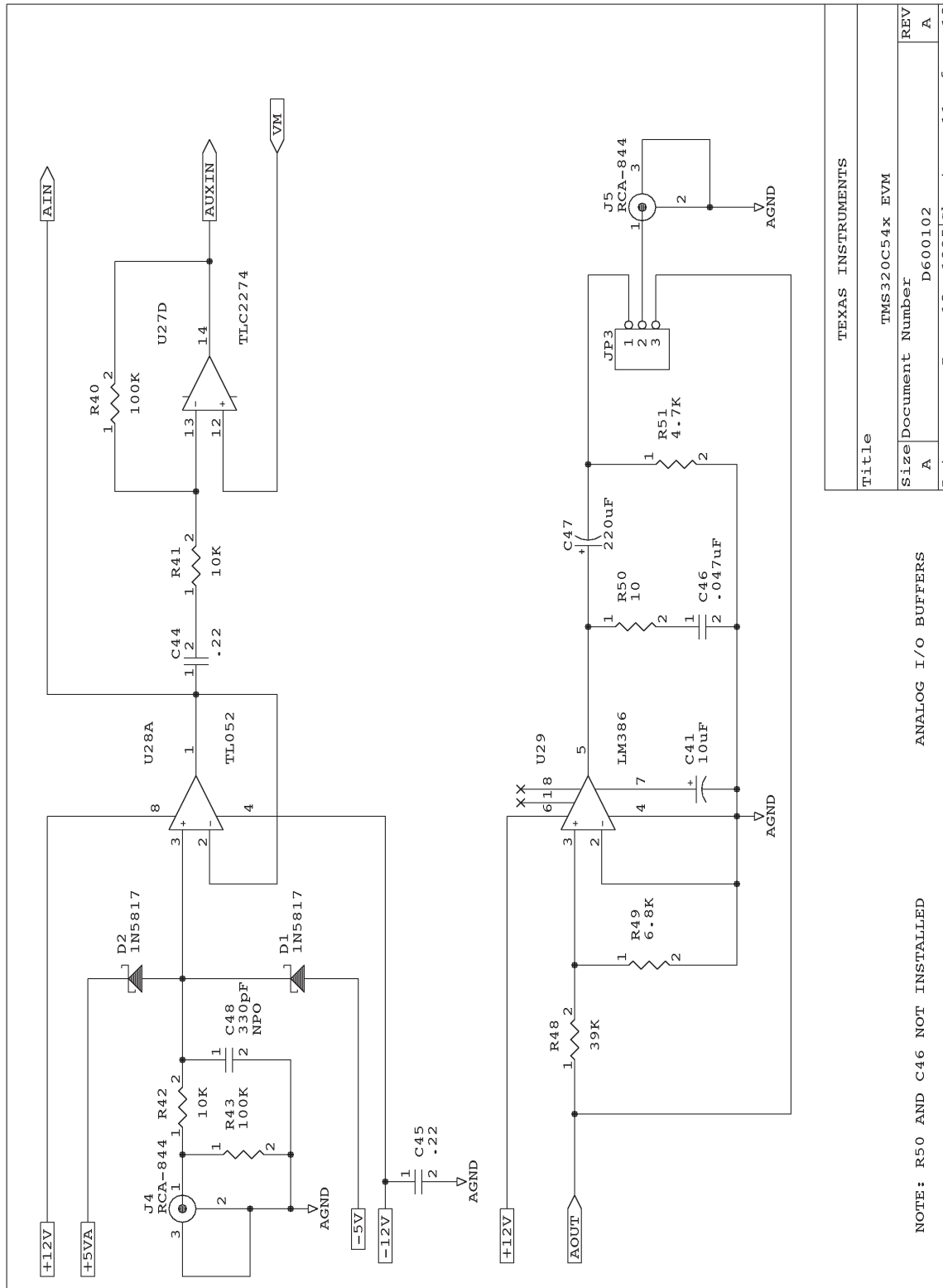

NOTE: R50 AND C46 NOT INSTALLED

ANALOG I/O BUFFERS

TEXAS INSTRUMENTS	
Title	
TMS320C54x EVM	
Size	Document Number
A	D600102
REV	
A	
Date:	June 13, 1995
Sheet	11 of 13

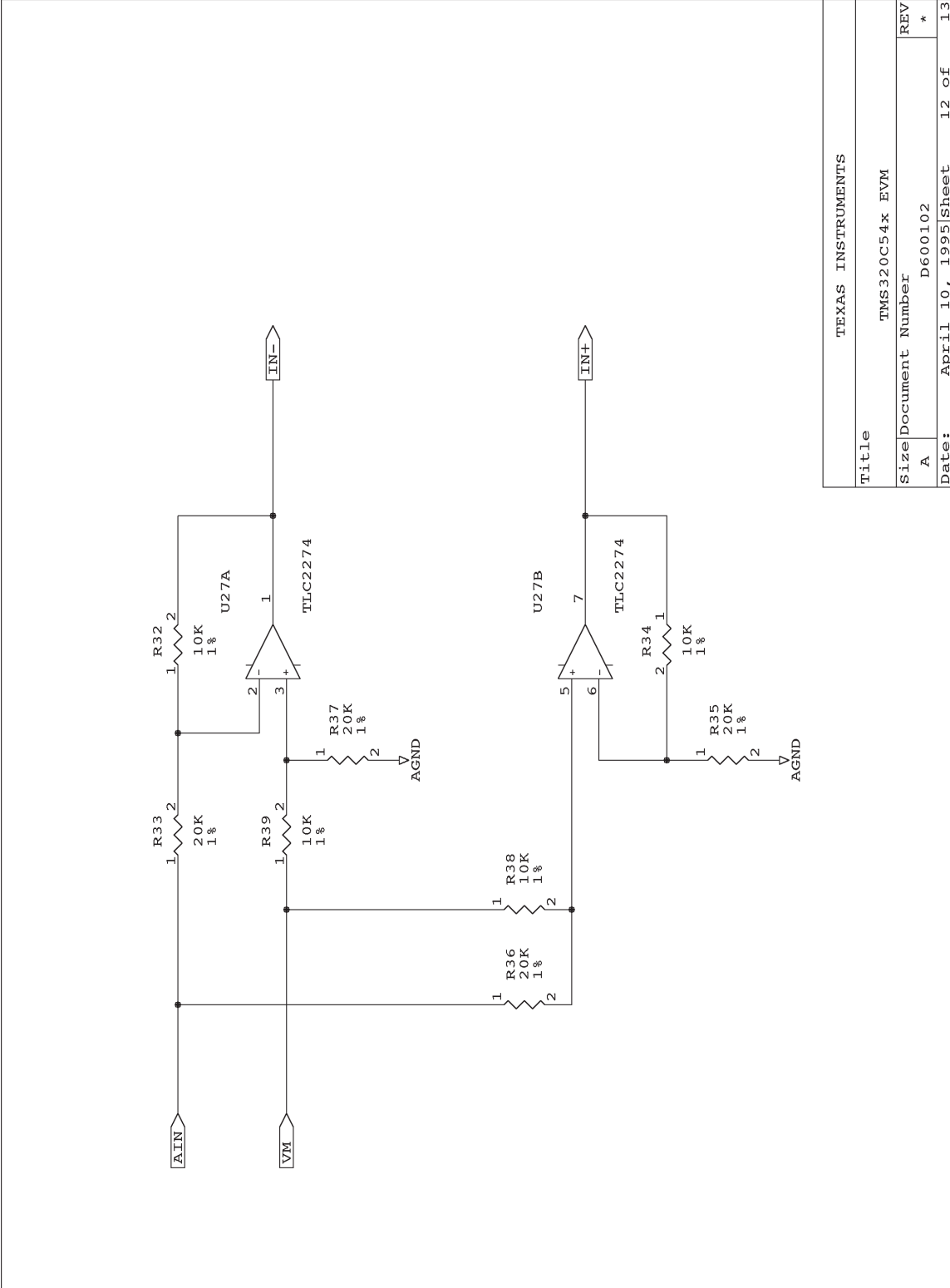

TEXAS INSTRUMENTS	
Title	TMS320C54x EVM
Size	A
Document Number	D600102
REV	*
Date:	April 10, 1995
Sheet	12 of 13

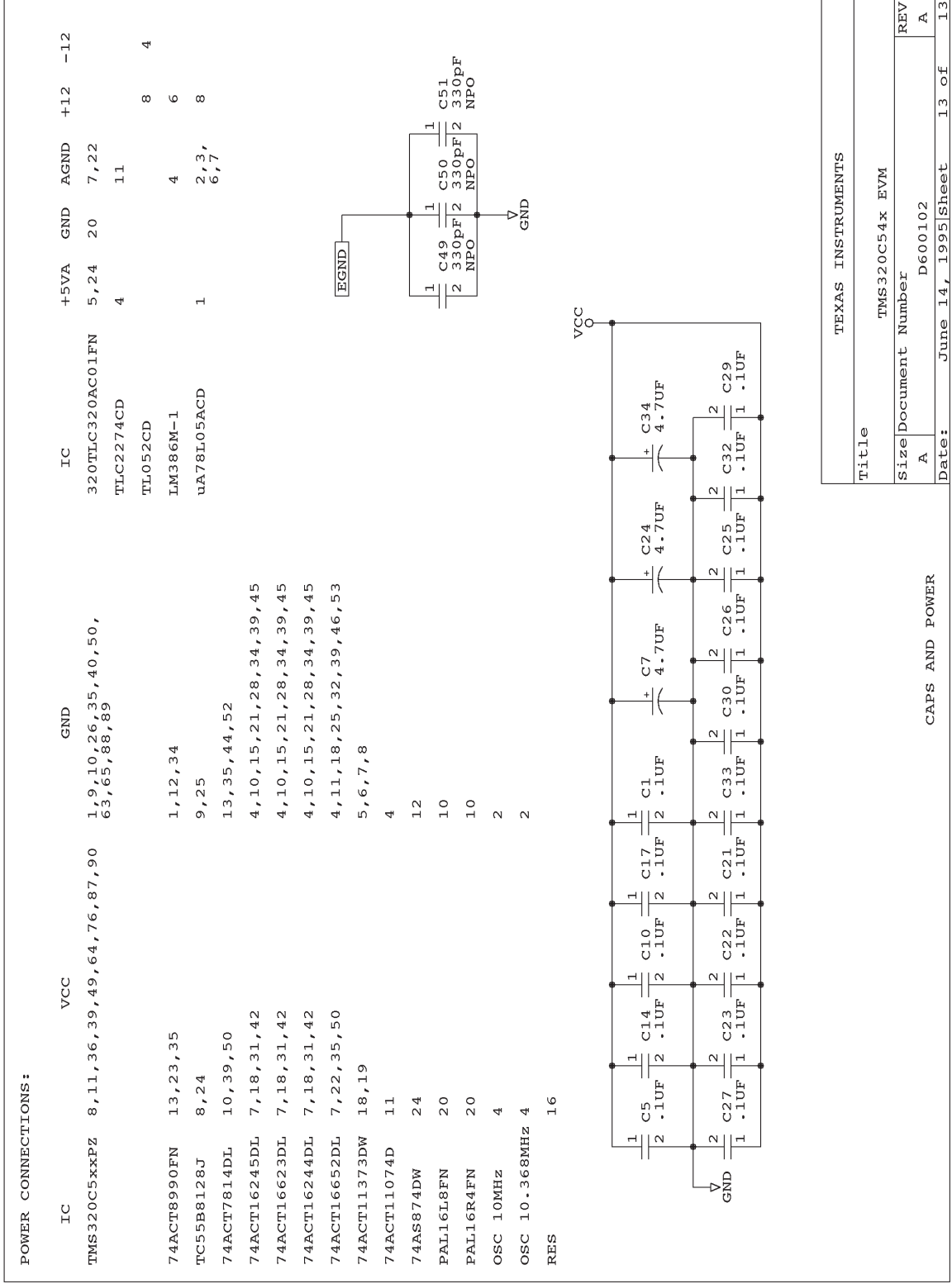

TEXAS INSTRUMENTS	
Title	
TMS320C54x EVM	
Size	Document Number
A	D600102
REV	
A	
Date:	June 14, 1995
Sheet	13 of 13

CAPS AND POWER

Index

A

- analog interface 3-14 to 3-15
 - analog input 3-14
 - analog output 3-15
 - considerations* 3-16
 - features 3-14
- application considerations 3-16
 - analog output 3-16
 - parallel I/O 3-17
 - shared resources 3-16

B

- board layout 2-2

C

- channel A
 - description 3-4, 3-6
- channel B
 - description 3-4, 3-7
- configuration 1-3

D

- debugger
 - emulation interface 3-15

E

- emulation interface 3-15
- evaluation module. *See* EVM
- EVM
 - board layout 2-2
 - functional overview 1-3
 - host requirements 2-3

EVM (continued)

- key features 1-2
 - operation 3-1 to 3-17
 - overview 1-1 to 1-3
 - schematics B-1 to B-14
 - setting switches for I/O space 2-4
- external serial port 3-13

F

- functional overview 1-3

H

- host control register
 - bit definitions 3-5
 - description 3-4 to 3-5
- host equations
 - address decode A-4 to A-5
 - decode A-2 to A-3
 - interrupt logic A-10 to A-13
- host interface
 - host/target communications 3-9 to 3-12
 - example using channel A* 3-12
 - example using channel B* 3-11 to 3-12
 - features* 3-9 to 3-10
 - interrupt selection 3-6
 - PC/AT interface 3-3 to 3-6
 - register usage 3-4 to 3-5
 - See also host control register*
 - offsets* 3-3
 - requirements 2-3

I

- I/O interface 3-6 to 3-9
 - See also* target control register
 - channel A 3-6
 - channel B 3-7

I/O interface (continued)
 expansion bus signals 3-9
 expansion I/O ports 3-6
 parallel I/O considerations 3-17
 port usage 3-7
 status I/O port 3-7

I/O space
 EVM switch settings 2-4
 mapping 2-4
 requirements 2-3

interrupts
 host interrupts 3-6

J

J1
 I/O expansion bus signals 3-9
JP1
 host interrupts 3-6

K

key features 1-2

M

memory 1-3
 interface 3-2
 precedence 3-2
 wait states 3-2
 requirements 2-3

O

operation 3-1 to 3-17

P

PAL equations A-1 to A-16
 host address decode A-4 to A-5
 host decode A-2 to A-3
 host interrupt logic A-10 to A-13

PAL equations (continued)
 miscellaneous logic A-8 to A-9
 target address decode A-6 to A-7
 target interrupt logic A-14 to A-16

PC/AT host interface 3-3 to 3-6
 See also host interface

ports 3-7
 See also I/O interface
 external serial port 3-13

power
 requirements 2-3

S

schematics B-1 to B-14
serial port 3-13
signals
 expansion bus signals 3-9
 external serial port signals 3-13
status/control register
 description 3-4

T

target control register
 bit definitions 3-8
 description 3-7 to 3-8
target equations
 address decode A-6 to A-7
 interrupt logic A-14 to A-16
target/host communications. *See* host interface,
 host/target communications
test bus controller 3-4
TMS320C54x
 See also I/O interface
 memory interface 3-2
 precedence 3-2
 wait states 3-2

W

wait states 3-2