

# Channel-Link PCB and Interconnect Design-In Guidelines

National Semiconductor  
Application Note 1108  
John Goldie  
August 1998



## LINK INTRODUCTION

The Channel Link Transmitter's function is to convert a wide parallel TTL bus into a smaller faster LVDS interface, and the Receiver's function is to recover the data and re-generate the wide TTL bus. The system block diagram is shown in *Figure 1*. Channel Link delivers multiple benefits to Datacom and Telecom applications. These include a smaller LVDS interface which saves PCB space, simplifying the task of PCB trace layout. The LVDS drivers are capable of driving long cables (up to 10 meters) at high speeds. The smaller cables and connectors are lower cost since they are physically

smaller (up to 80% reduction in the number of required conductors/pins). LVDS supports higher bandwidth service with a reduction in EMI due to the differential scheme (odd mode), the reduced signal swing (only ~300 mV), and the use of current mode drivers (soft transitions, and reduced spikes). To gain the maximum benefits of LVDS and Channel Link, high speed PCB and interconnect design is *required*. This application note focuses on the requirements of the PCB and interconnect to provide an error free, low emission LVDS interface.

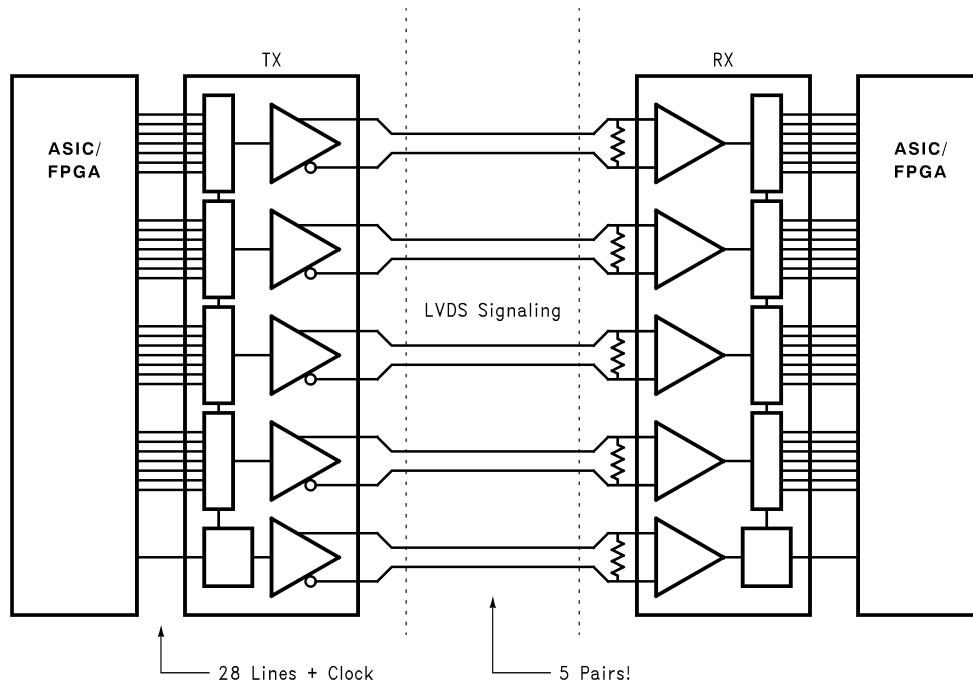

FIGURE 1. Link System Block Diagram

## FUNCTION OF THE TX AND RX

The Transmitter (TX) accepts the wide parallel (21-bit or 28-bit) TTL bus and converts it to 3 or 4 higher speed serialized LVDS data streams. Applications may employ the full payload (21 or 28 bits) of the chipset or only a portion (i.e. 14, 16, 17, 18, 20 bit wide). To operate the TX, only data and clock must be applied. The chip does not require control signals, as it provides transparent data transmission. Data on the TX inputs is strobed into the TX on the rising edge of the clock signal. This edge is denoted within the device ID with the "R" designation. The clock is then fed to a PLL type circuit that is used to generate strobes that internally clock out the serialized LVDS data streams. A powerdown pin is also

supported. Asserting this pin shuts down the PLL and also puts the driver outputs into TRI-STATE<sup>®</sup>. This mode disables the LVDS load loop current and also reduces  $I_{CC}$  to  $\mu$ As, saving power when the link is not needed. The 3.3V TX devices feature high impedance bus pins when the device is powered off.

The Receiver (RX) accepts the 3 or 4 high speed serialized LVDS data streams and converts them back to a wide parallel TTL bus. The RX device is the complementary function to the TX device. Data on the RX output is strobed by the RX-CLKout on the rising edge of the clock signal. This edge is denoted within the device ID with an "R". The RXs utilize the rising edge of the LVDS Clock signal to strobe the data on

TRI-STATE<sup>®</sup> is a registered trademark of National Semiconductor Corporation.

the RX LVDS data inputs. A powerdown pin is also supported. Asserting this pin shuts down the PLL and also locks the RX outputs to the current state or low state (device specific, see datasheets). This mode saves power when the link is not needed. The 3.3V RX devices also feature high impedance bus pins when the device is powered off. This feature enables multi-drop applications for single TX to multiple RX configurations.

#### LOCATION OF TX AND RX ON THE PCB

The transmitter should be located as close to the connector as possible (see *Figure 2*). This is done to minimize the LVDS PCB overall trace length (see following section on differential traces) and skew as well. Skew is generally proportional to length, thus a shorter interconnect has nominally less skew associated with it. If the TX is located within 2 inches of the connector, serpentine (trace length compensation to generate zero skew) is not required. If the TX is more than 2 inches away, equal length traces should be employed. It is not a requirement of the TX device to be located adjacent to the ASIC/FPGA (bus controller) device. Recall the ASIC-TX interface is a slow speed bus (compared to the LVDS bus) and has fewer timing constraints. However, the connection between the ASIC and the TX should be designed such that the parallel bus traces are also of equal

length to avoid excessive skew which could cause a set-up or hold violation at the TX input pins. In the extreme case (if electrical length is 1/2 rise time), signal termination may be required on the ASIC-TX interface. Note, the bus data lines are level sensitive only, while the clock line is edge sensitive. If the interconnect between the ASIC and the TX is long, (becomes a transmission line), termination for the clock signal should be considered. Input voltages applied to the TX input pins should remain within the VCC to GND range. Exceeding the ABS MAX ratings of the input pins increases noise in the device (and jitter) and can falsely trigger the ESD protection circuitry.

The receiver should also be located close to the connector as shown in *Figure 2*. This is done to minimize the LVDS PCB trace length. (see the section on differential traces.) It is not a requirement of the RX device to be located adjacent to the destination controller (ASIC/FPGA). If the distance is greater than a few inches, or for high fanouts (more than 2), external buffering of the RX outputs should be employed. The connection between the controller and the RX should be designed such that the parallel data bus traces are of equal length to avoid skew which could cause a set-up or hold violation at the ASIC controller input pins.

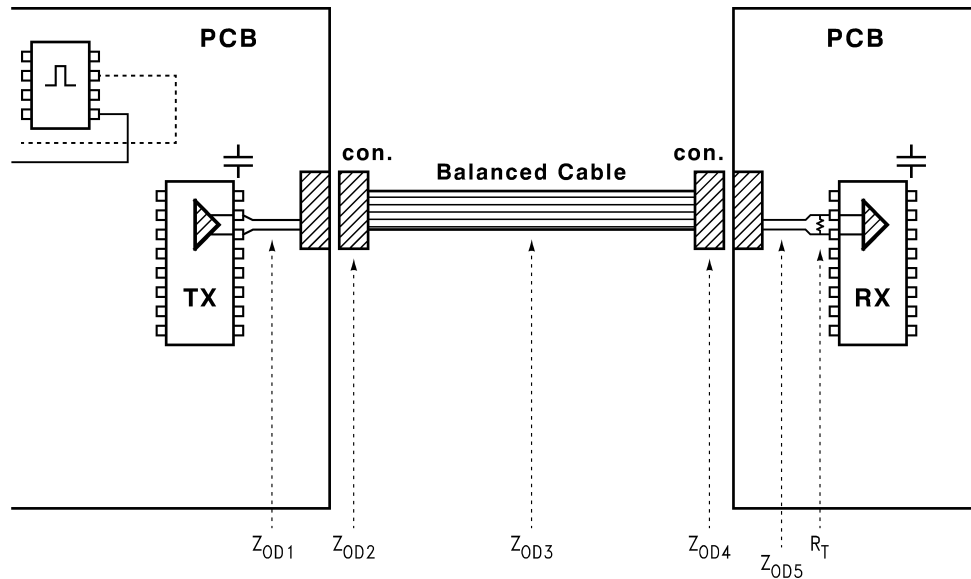

FIGURE 2. TX and RX Location

#### DEVICE GROUND AND POWER

The TX and RX are high speed—high performance devices. The devices include a PLL type circuit that operates at  $f$  or  $3.5Xf$  MHz (device specific, where  $f$  is the clock frequency) and LVDS drivers and receivers that toggle in the hundreds of Megabits per second range (up to 462 Mbps at a 66MHz clock rate!). This requires a solid ground and power distribution reference for the device.  $V_{CC}$  noise should not exceed 100 mV<sub>pp</sub>. If it does, separated power and ground planes should be used for the PLLV<sub>CC</sub> and PLLGND pins. To enable good power/ground reference a minimum of a 4 layer PCB is

recommended. Two sided boards or flex circuit are generally not recommended for placement of the TX or RX devices. EMI emission control starts with solid power and ground planes.

#### DEVICE BYPASS

The TX and RX have three separate V<sub>CC</sub> (power supply) and GND references. These are for the digital logic, LVDS, and PLL portions of the chip. To obtain supply noise of less than 100 mV<sub>pp</sub>, close by-passing is required. Do not locate by-pass capacitors at the end of small traces, rather connect

them adjacent to the device pins as close as possible. Bulk capacitance of 4.7  $\mu\text{F}$  to 10  $\mu\text{F}$  should also be near by. Wide traces with multiple power/GND via (2 are recommended) should be employed on bypass connections. The ideal case would use 0.1  $\mu\text{F}$ //0.01  $\mu\text{F}$ //0.001  $\mu\text{F}$  capacitors on each supply pin. If space is restricted do not eliminate the PLL bypassing as this is most critical of low noise operation. 0805 or 1206 chip capacitors are recommended as they offer the lowest inductance and can be mounted very close to the device pins. With this type of layout, parasitic inductance will be in the 1.5 nH to 2 nH range, whereas locating the capacitor at the end of a short narrow trace can have an inductance as high as 15 nH! Using multiple capacitors in parallel provides good bypassing across a wider range of frequency, also the ESR is lowered and a low impedance at high frequency is provided.

#### ASIC — TX INTERFACE

The connection between the ASIC controller and the TX device should utilize standard PCB design techniques. The data bus and clock lines should all be of equal length in order to prevent any skew being introduced between clock and data. As with any clock line, signal quality is of concern. Avoid unnecessary via, sharp bends or other discontinuities. A direct point-to-point link is best for the clock and its signal quality. Other clock signals should be kept away from the clock and data lines to avoid unwanted coupling. Provision for termination may be required on the clock signal at the TX input. If the ASIC has drive level options (6 mA–8 mA or 12 mA modes, device specific), testing has shown that operating the clock in high drive and the data in low offers the best balance between clock signal quality (sharp) and noise generation from the ASIC data output pins. Unused TX input pins should be tied to GND on the 5 V series and may be left

floating or tied to GND on the 3.3 V series to prevent unwanted switching and the lowest chip power dissipation. The 3.3 V devices feature internal pull down resistors on the inputs (see datasheets).

#### RX — ASIC CONTROLLER INTERFACE

The connection between the RX and the ASIC controller should utilize standard PCB design techniques. The data lines and clock should all be of equal length in order to prevent any skew being introduced between clock and data. As with any clock line, signal quality is of concern. Avoid unnecessary vias, sharp bends or other discontinuities. A direct point to point link is best for the clock and its signal quality. If a high fanout of the RX output is required (more than 2 loads), external buffering is recommended.

#### LVDS DEVICE — CONNECTOR INTERFACE

The traces that connect the TX LVDS outputs to the connector and the connector to the RX inputs should be minimized in length as discussed above in the section on TX/RX location. In addition TTL/CMOS single-ended lines should be located on a different signal layer or kept away (at least "3S") from the LVDS lines to minimize any coupling of noise onto the LVDS lines and out onto the interconnect as shown in *Figure 3*. Guard ground traces may be placed between the LVDS lines and the other signals to further isolate the two, they should be at least 2S away from the closely-coupled differential pair. Corruption of LVDS data is not an issue due to the receiver's common mode rejection; minimizing common mode noise (EMI) is the reason for the spacing and isolation. Unused LVDS driver output pins should be left open, as this will minimize power dissipation. Unused RX inputs should also be left open (not terminated).

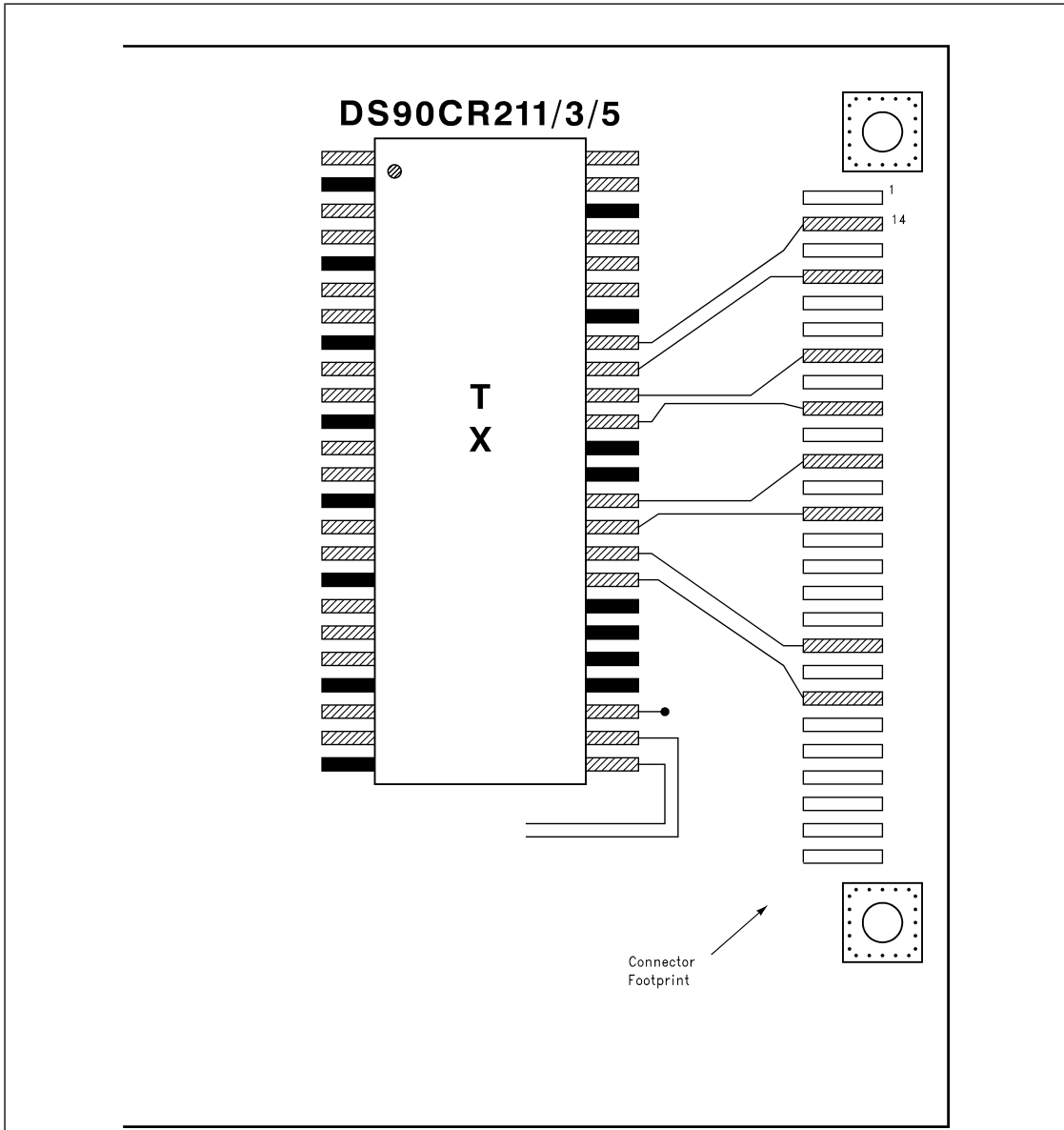

AN100882-3

FIGURE 3. LVDS PCB Layout

The use of true differential traces further enhances the noise rejection capabilities of differential data transmission and reduces / limits the generation of unwanted emissions. Differential traces are recommended for use on the LVDS outputs of the TX and inputs to the RX. They differ only slightly from standard PCB traces. The distance between the two signal traces ("S") that compose the differential pair is also controlled (minimized). This distance is critical to specify correctly as it is related to both the differential-mode characteristic impedance of the trace pair and also related to the differential noise margin of the system. Standard traces are laid out for 50Ω impedance. Two traces separated far apart

from each other will present a differential mode characteristic impedance of twice the single-ended impedance, but will not provide the maximum noise rejection benefit and defeat the differential signaling. The spacing between the traces should be kept to a minimum to maximize the differential noise rejection (differential noise margin is equal to the minimum signal swing less the maximum receiver thresholds (250 mV–100 mV = 150 mV)). This minimum distance between the traces of a pair assures that any external noise coupled onto the pair will be seen as common mode, and rejected by the receivers. To adjust trace impedance set "S" to a minimum spacing between metal lines), and adjust the

width of the trace to the desired impedance (see AN-905 for equations). When the two lines are close, the differential impedance is no longer twice the single-ended impedance (it is a factor of  $<2$ ). The distance between adjacent LVDS differential pairs should be at least  $2S$  or greater as shown in *Figure 4*.

*Figure 4*. The electrical length of the LVDS traces should be matched to minimize any skew created in the path between TX and RX. Lastly, it is desirable to have  $S < h$ , again ensuring that maximum coupling occurs between the pair and not with the plane below.

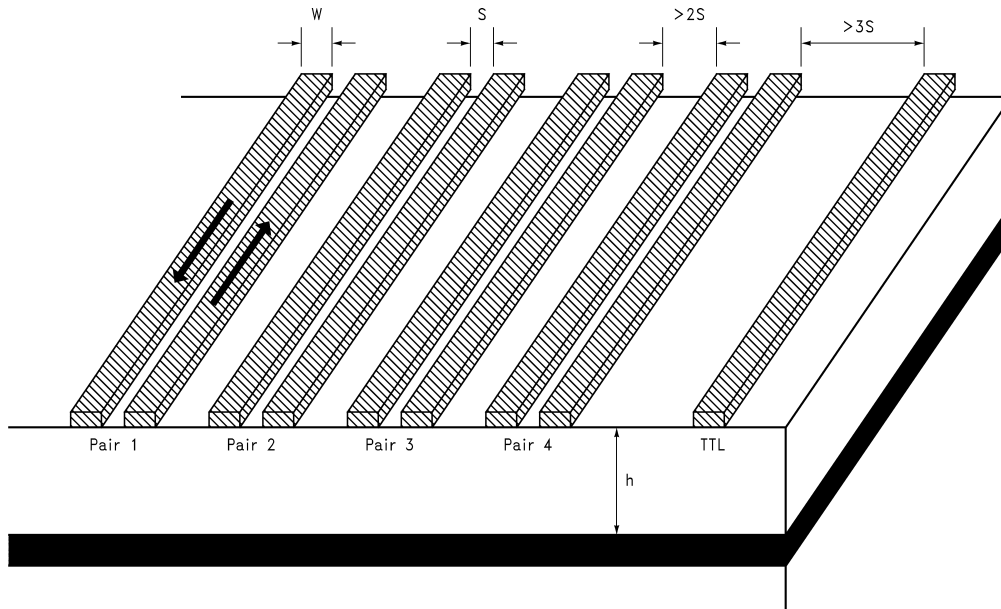

AN100882-4

**FIGURE 4. Differential Trace Spacing**

Microstrip traces (outside layer) are usually employed for this interconnect. The microstrip geometry and the fact that the traces are on the outer layer enable higher impedances more easily. It is also possible to design the interconnect without any via, thus a better signaling environment. On the down side, stripline (embedded) traces offer greater shielding due to their encasement. Either microstrip or stripline traces can be used, as long as they are matched to the cable's differential-mode characteristic impedance. This is shown in *Figure 2* where  $Z_{OD1}$  represents the TX PCB impedance and  $Z_{OD3}$  is the cable (interconnect) impedance. It is recommended that all impedances should be within 10% of the target impedance (typically  $100\Omega$ ) to minimize any reflections. Note that a 10% difference in impedance will create a reflection of 5%. Reducing the magnitude of reflections will lower the EMI of the system.

#### TERMINATION AT THE RX INPUTS

The use of a termination resistor is required. Due to the high speed edge rates of LVDS drivers a matched termination will prevent the generation of any signal reflections, and reduce

EMI. Termination is typically implemented with a single surface mount resistor connected across the signal pair as close to the receiver inputs as possible (no more than  $1/2$  inch away if the termination is placed in front of the receiver inputs). If the resistor is too far away from the receiver inputs, the line between the resistor and the receiver input takes on transmission line behavior and reflections may occur at the receiver inputs defeating the purpose of the termination resistor altogether! Also the use of an external resistor allows for a variety of media to be used. Since characteristic impedance is media dependent, the proper termination resistance may be employed to match the particular application. The resistor should be selected to within 2% of the nominal differential impedance ( $100\Omega$ ) of the media. If PCB space is tight, a fly-by termination may also be used. The two termination methods are shown in *Figure 5*. In either case the resulting stub should be kept as short as possible.

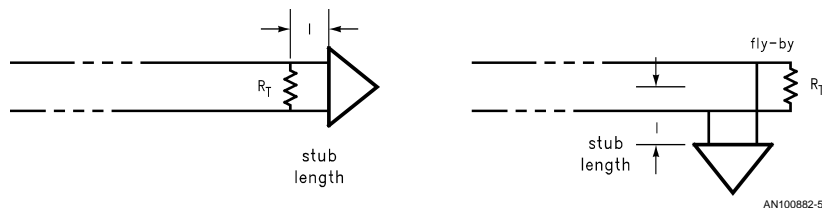

**FIGURE 5. Termination Layout— Standard and Fly-By**

**Note:** The *complete* interconnect between the TX output and the RX input is a high speed transmission line. Driver edge rates are in the 300 ps–700 ps range. The TX PCB traces, connectors, cable media, and RX PCB traces are all part of the system. Their impedances should be matched within 10% to maintain signal quality and generate the lowest amount of emissions. There are 4–6 impedances to consider, depending upon the application (the size of the connector). These are shown in *Figure 2* as  $Z_{OD1}$ ,  $Z_{OD2}$ ,  $Z_{OD3}$ ,  $Z_{OD4}$ ,  $Z_{OD5}$ , and  $R_T$ . Also, minimize extra transitions (board or layer transitions, etc.) here to make this total interconnect as clean as possible.

### CONNECTORS

For intra-box applications (board to board in a box) the connector is typically very small since it is internal to the box and is only connected upon assembly of the system. These connectors have the advantage that they do not adversely effect the signal quality greatly, since they are electrically small and present more of a small lumped load to the signal.

Larger connectors used between boxes (box to box application) are more critical since they are electrically long and may react as a transmission line segment. High performance connectors are available that provide controlled impedance and matched electrical length of the pins (no skew). The 3M MDR system is one such cabling system that meets the needs of LVDS applications for cable and connector requirements. It offers a zero skew SMT connector, controlled impedance, low crosstalk, and very low skew (see reference in the appendix). Other connectors that have been employed include standard SCSI connectors, and also DB15 connectors to name a few.

### CONNECTOR PINOUT

Connector Pinout is application dependent. General guidelines to follow are given below.

On multiple row connectors, the pair should be routed on adjacent pins in the same row to minimize skew within the pair. Another option is to employ single row low skew surface mount connectors (see reference).

A signal common (ground) path should also be provided near the pairs to provide a low impedance near by return path for common mode noise picked up along the cable. This will help to reduce unwanted EMI.

### THE INTERCONNECT

LVDS drivers and receivers are intended to operate on a wide variety of media. Depending upon the system's needs the media may vary due to a number of parameters including: length of interconnect, amount of shielding required, physical dimensions of the system, and of course cost. Channel Link (LVDS) has been demonstrated on flat ribbon cable, FEC (flex) interconnect, shielded twisted pair, and twin axial cables. An important parameter to understand is the differential-mode characteristic impedance of the media. For many common cables this is typically about 100Ω (see cable datasheet). As discussed above to minimize any common mode noise generation the TX PCB interconnect, the interconnecting media, the RX PCB interconnect, and the termination should all match (within 10%) in characteristic impedance (differential mode). Electrical length of the data

and clock signals should be of equal length. Conductors of different length composing a pair will cause a modulation of common mode and radiate more. Pairs of different length will impact the receivers data recovery by impacting the correct strobing of data. Remember that the timing of the LVDS data line is 7X tighter than of the TTL bus. The amount of tolerable skew between any two conductors is clock speed dependent, but should be kept to less than 100 ps–400 ps (data rate dependent, 66 MHz–20 MHz) with the Link chips. On a typical high performance cable (3M MDR) skew is specified at only 30 ps/meter. For flex circuit interconnects, similar design recommendations as discussed in the “LVDS Device—connector interface” section above should be employed. Even through LVDS operates as true odd-mode differential drivers, a signal common (Ground) connection is required between the two systems to establish a common-mode return path. The bulk of the LVDS load current is returned to the driver within the pair as LVDS is a true odd-mode differential driver. This is very important for emission reasons, as the closely-coupled differential pair creates a small ring antenna. However, for common mode return, a signal common connection of low impedance is required for low emission operation. Typically assigning one pair (two conductors) is sufficient for this purpose (as it has 1/2 the DCR (DC resistance) of a single line). Shield ground references should be tied off to quiet ground references, typically frame ground at each end if employed. Channel Link (LVDS) may be used on a wide variety of media (flat cable, twin-ax, standard twisted pair,...cables). Length is a factor of cable performance, balance, skew, and clock speed, thus it is application dependent.

General guidelines for different types of cable are given next: for very short distance applications (less than 0.3 meter) flat cable or flex circuit has been employed. For medium distance applications (less than 7 meters) standard twisted pair cables have been employed. For application exceeding 5 meters, typically twin-ax cables have been employed due to their inherent low skew between pairs. Greater than 10 meter applications are possible, however sampling margin, skew, and impedance control must be carefully reviewed. The Channel Link chipsets are offered currently in 3 speed families. Very general conservative guidelines for How far? How fast? are given below for the chipsets:

- 40MHz Family → up to 10 meters
- 66MHz Family → up to 5 meters
- 85MHz Family → up to 2 meters

#### BIT MAPPING

The bit mapping for the 21 and 28 bit chipsets are shown in the respective datasheets. Bit mapping is the same for all 21 bit parts (40, 66, and 85MHz families). Bit mapping is the same for all 28 bit parts (40, 66, 85MHz families). Note that the 21 and 28 bit part families are mapped differently. Mixing 3.3V and 5V devices is also possible, since all devices adhere to the LVDS interface standard.

If less than 21 or 28 bits are required, multiple options to disable particular bits are possible. The following options are possible:

If there are 7 unused bits, then it is possible to utilize only 2 LVDS data streams (21 bit chipset example). This will lower the size of the interconnect required. Unused TX inputs should be left open on the 3.3V family (and tied to GND on the 5V family of TXs). The unused LVDS channel outputs should also be left open to minimize current (power dissipation). Unused RX inputs may also be left open, as these inputs feature a failsafe feature that pulls the plus input high and the minus input low, preventing unwanted transitions. Unused RX outputs should also be left open to minimize power dissipation.

If there are only one to seven unused bits in the application, then bits on each channel may be disabled. This can be used to enhance signal quality on the cable as well for long cable applications. By disabling two data bits in the data stream (tie one HIGH and the other LOW), inserts guaranteed transitions on the data channel and improves (opens) the eye pattern (reduces ISI distortion of NRZ data).

#### CHIPSET OPERATION

The Channel Link chipset provides transparent data transmission with minimum control overhead. Data and clock simply need to be applied to the transmitter input pins. Once the TX PLL is locked (10ms max) and the RX PLL is locked (10ms max), data transmission is enabled.

#### MHz and Mbps

Mega Hertz and "Mega bits per second" are two terms that are commonly confused. Mega Hertz (MHz) is a measure of the clock period applied to the TX clock input. Mega bit per second is the information rate, and for NRZ data is the measure of a single bit width. It is also important to indicate where the bit rate is being measured. For the Link chipset, there are three different possible bps values. These are:

1. the bit rate on a single TX input
2. the bit rate on a single LVDS data channel

3. the bit rate on the entire link (3 or 4 LVDS channels combined)

For example, with a 66MHz clock, and with data strobed on the rising edge, the bit rate on a single TX input is 66Mbps. The bit rate on a LVDS channel is 7X the input rate, or 462Mbps. The bit rate on the entire 28 bit Channel Link is 4X the LVDS channel rate, or 1.848Gbps.

#### SUMMARY

High speed PCB and Interconnect design practices should be employed to ensure an error free, low emission design for the Channel Link devices. The interconnect is a transmission line due to the high speed edge rates of the LVDS signals (500 ps typical). Tight skew control is required to minimize emissions and proper data recovery at the RX devices. Matching impedances within 10% is recommended to reduce the creation of reflections (even mode) along the interconnect/cable.

#### GENERALIZED PCB RECOMMENDATIONS OF LVDS AND LINK APPLICATIONS

LVDS features fast edge rates, therefore the interconnect between transmitters and receivers will act as a transmission line. The PCB traces that form this interconnect must be designed with care. The following general guidelines should be adhered to:

- Hand route or review very closely auto-routed traces.
- Locate the Transmitters and Receivers close to the connectors to minimize PCB trace length for off PCB applications.
- LVDS traces should be designed for differential impedance control (space between traces needs to be controlled). See AN-905 for equations.
- Minimize the distance between traces of a pair to maximize common mode rejection.
- Place adjacent LVDS trace pairs at least twice (2S) as far away (as the distance between the conductors of the pair).
- Place TTL/CMOS (large dV signals) far away from LVDS, at least three times (3S) away or on a different signal layer.
- Match electrical length of all LVDS lines.
- Keep stubs as short as possible.
- Avoid crossing slots in the ground plane.
- Avoid 90° bends (use two 45s).
- Minimize the number of via on LVDS traces.
- Maintain equal loading on both traces of the pair to preserve balance.
- Match impedance of PCB trace to connector to media (cable) to termination in order to minimize reflections (emissions) for cabled applications (typically 100Ω differential mode impedance).
- Select a termination resistor to match the differential mode characteristic impedance of the interconnect, 2% tolerance is recommended.
- Locate the termination within 1/2 (<1) inch of the receiver inputs if not using a fly-by termination method.
- Use surface mount components to minimize parasitic L and C for bypass caps and termination resistors.
- Use a 4 layer PCB (minimum).

- Bypass each LVDS package at the device pin (Bulk bypass nearby also) with parallel capacitors (0.1  $\mu$ F//0.01  $\mu$ F//0.001  $\mu$ F) on each of the supply pins ( $V_{CC}$ , LVDS  $V_{CC}$ , and PLL  $V_{CC}$ ).

**APPENDIX**

**Related Channel Link and LVDS Application Notes from National:**

AN-XXX	Topic
AN-905	Differential Impedance Calculations
AN-1041	Introduction to Channel Link
AN-1059	SKEW and Jitter Calculations
AN-1084	Links in Parallel
AN-1109	Multidrop Applications with Channel Link

**Related Application Notes**

High speed LVDS Transmission Information:  
 High Performance Shielded Twin-ax Cable Assembly, Part Number 14526  
 SMT R/A Receptacle (26 position), Part Number 10226-1210VE  
 3M Tech Paper: "Selecting the "Right" Right Angle Interconnects: Surface Mount vs Through-hole" by Francis G. Hart  
 3M Electronics products Division, Austin, Texas; Kay Tohyama, Yamagata 3M Limited, Yamagata, Japan.

**LIFE SUPPORT POLICY**

NATIONAL'S PRODUCTS ARE NOT AUTHORIZED FOR USE AS CRITICAL COMPONENTS IN LIFE SUPPORT DEVICES OR SYSTEMS WITHOUT THE EXPRESS WRITTEN APPROVAL OF THE PRESIDENT OF NATIONAL SEMICONDUCTOR CORPORATION. As used herein:

1. Life support devices or systems are devices or systems which, (a) are intended for surgical implant into the body, or (b) support or sustain life, and whose failure to perform when properly used in accordance with instructions for use provided in the labeling, can be reasonably expected to result in a significant injury to the user.
2. A critical component in any component of a life support device or system whose failure to perform can be reasonably expected to cause the failure of the life support device or system, or to affect its safety or effectiveness.

 <p><b>National Semiconductor Corporation</b>                  Americas                  Tel: 1-800-272-9959                  Fax: 1-800-737-7018                  Email: support@nsc.com</p> <p>www.national.com</p>	<p><b>National Semiconductor Europe</b>                  Fax: +49 (0) 1 80-530 85 86                  Email: europe.support@nsc.com                  Deutsch Tel: +49 (0) 1 80-530 85 85                  English Tel: +49 (0) 1 80-532 78 32                  Français Tel: +49 (0) 1 80-532 93 58                  Italiano Tel: +49 (0) 1 80-534 16 80</p>	<p><b>National Semiconductor Asia Pacific Customer Response Group</b>                  Tel: 65-2544466                  Fax: 65-2504466                  Email: sea.support@nsc.com</p>	<p><b>National Semiconductor Japan Ltd.</b>                  Tel: 81-3-5620-6175                  Fax: 81-3-5620-6179</p>
--	---	---	---