

# A Low Cost, Low Parts-Count DC/DC Converter With Multiple Outputs

National Semiconductor  
Application Note 1081  
Musiri Srivathsan  
May 1997



A Low Cost, Low Parts-Count DC/DC Converter With Multiple Outputs

## I. INTRODUCTION

This application note describes a simple low cost, low parts-count multiple output DC/DC converter based on the LM2596 five terminal step-down switching regulator. The circuit described provides multiple output voltages (positive and negative) with good regulation using a step-down converter circuit with flyback windings. It uses only one switching regulator IC.

## II. PERFORMANCE

The circuit has an input voltage range of 15V to 40V. It has 5 outputs: 3.3V at 1.5A; +12V and -12V at 50 mA each; and +5V and -5V at 50 mA each. The 3.3V, +5V and -5V outputs

are regulated with  $\pm 5\%$  accuracy over line and load variations. The +12V and -12V outputs are regulated with  $\pm 20\%$  accuracy. A typical application of this circuit is where the 3.3V output provides the power to the main circuit which is 3.3V logic, the  $\pm 5V$  outputs power the 5V logic and  $\pm 12V$  outputs provide the bias supply of op-amps.

The efficiency of the circuit with full load at all outputs is 75%. The ripple voltage across the 3.3V output is less than 20 mV and that across the  $\pm 12V$  outputs is less than 30 mV. The ripple across the  $\pm 5V$  is less than 10 mV.

## III. SCHEMATIC AND PARTS LIST

Figure 1 shows the schematic of the circuit.

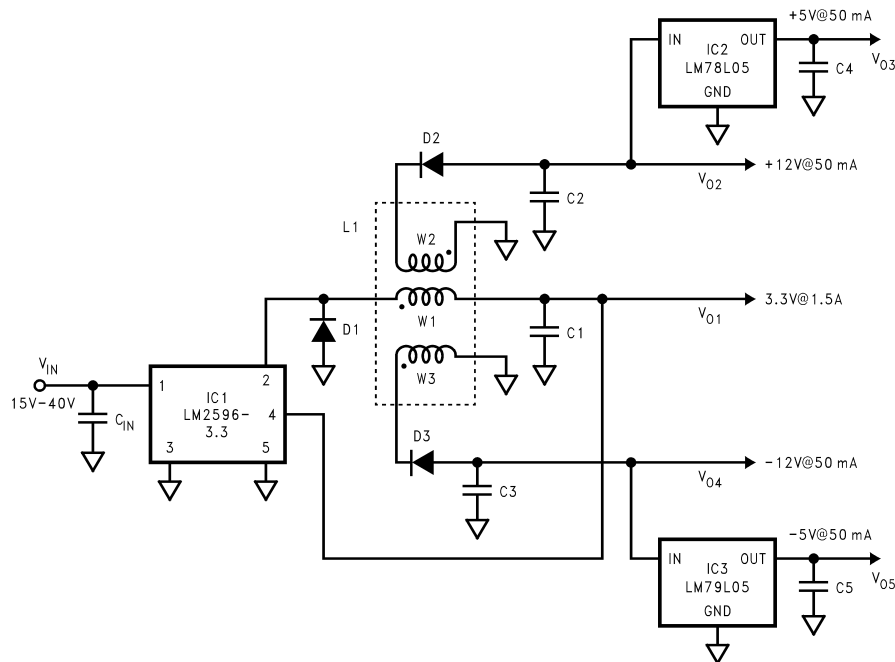

FIGURE 1. Circuit Schematic

The parts list for the circuit is:

Cin : 220  $\mu$ F, 50V, Nichicon UPL1H221MPH,  
C1: 270  $\mu$ F, 63V, Nichicon UPL1J271MRH,  
C2, C3: 47  $\mu$ F, 35V, Nichicon UPL1V470MPH,  
D1: MBR360,  
D2, D3: 1N459,

C4, C5: 0.01  $\mu$ F,  
IC1: LM2596-3.3 (SIMPLE SWITCHER® Step-Down Voltage Regulator),  
IC2, IC3: LM78L05, and LM79L05. (3- Terminal Regulators),  
L1: Custom Inductor with three windings (W1, W2 and W3) with the following specs:

SIMPLE SWITCHER® is a registered trademark of National Semiconductor Corporation

W1: 47  $\mu$ H; Peak Current: 2.6A, RMS Current = 2.32A  
W2: Number of turns = 3.4 x Number of turns in W1; RMS Current; 113 mA  
W3: Same as W2.

#### IV. CIRCUIT OPERATION

The circuit operates as a standard step-down (buck) switching regulator, except for the flyback windings (W2, W3). The flyback windings conduct current during the on-period of D1 and supply the 3-terminal regulators (IC2 and IC3). C2 and C3 should be of high enough value to smooth out the high ripple due to the flyback action of W2 and W3. The flyback windings supply the +12V and -12V outputs with  $\pm 20\%$  accuracy. The 3-terminal regulators are used to provide +5V and -5V with  $\pm 5\%$  accuracy. The LM2596 regulates the main output (3.3V) by standard step-down action.

#### V. DESIGN

##### Step 1: Design of Step-Down Regulator for the Main (3.3V) Output

This can be done using the *Switchers Made Simple* software by National Semiconductor. The following values (underlined>

$V_{IN(min)}$ : 15V

$V_{IN(max)}$ : 40V

$V_{OUT}$ : 3.3V

$I_{OUT}$ :

$$I_{OUT} = I_{O1} + N (I_{O2} + I_{O3} + I_{O4} + I_{O5}) \quad (1)$$

1.5A is the load for the 3.3V output.  $I_{O1}$ ,  $I_{O2}$ ,  $I_{O3}$ ,  $I_{O4}$  and  $I_{O5}$  are the load currents of outputs  $V_{O1}$ ,  $V_{O2}$ ,  $V_{O3}$ ,  $V_{O4}$  and  $V_{O5}$  respectively. N is the turns ratio between W2 and W1 (also between W3 and W1). It is calculated using

$$N = \frac{V_{O2} + V_{FD2}}{V_{O1} + V_{FD1}} = \frac{12 + 0.7}{3.3 + 0.4} = 3.4 \quad (2)$$

In this equation  $V_{FD2}$  is the forward voltage drop of D2 and  $V_{FD1}$  is the forward voltage drop of D1.

Using (1),  $I_{OUT} = 1.5A + 3.4 (50 \text{ mA} + 50 \text{ mA} + 50 \text{ mA} + 50 \text{ mA}) = 2.18A$

$I_{OUT} = 2.18A$ .

The software designs the step-down regulator and gives the following values:

IC1: LM2596-3.3

$C_{IN}$ : 220  $\mu$ F, 50V, Nichicon UPL1H221MPH

C1: 270  $\mu$ F, 63V, Nichicon UPL1J271MRH

D1: MBR360

L1: 47  $\mu$ H.

IC  $I_{pk}$ : 2.38A.

$C_{IN}$  and C<sub>1</sub> have been chosen primarily for ESR, not for voltage rating.

##### Step 2: Design of L1 and Flyback Outputs

###### a) Design of L1

The value of inductance due to W1 is the same as the value of L1 obtained in Step 1. The number of turns in windings W2 ( $N_{w2}$ ) and W3 ( $N_{w3}$ ) are

$$N_{w2} = N_{w3} = N \times \text{Number of turns in W1} \quad (3) = 3.4 \times \text{Number of turns in W1.}$$

The peak current in W2 ( $I_{pkw2}$ ) is

$$I_{pkw2} = \frac{I_{O2} + I_{O3}}{1 - \frac{V_{O1}}{V_{in(min)}}} = \frac{0.05 + 0.05}{1 - \frac{3.3}{15}} = 128 \text{ mA.} \quad (4)$$

The peak current in W3 ( $I_{pkw3}$ ) is

$$I_{pkw3} = \frac{I_{O4} + I_{O5}}{1 - \frac{V_{O1}}{V_{in(min)}}} = \frac{0.05 + 0.05}{1 - \frac{3.3}{15}} = 128 \text{ mA.} \quad (5)$$

The RMS current of W2 ( $I_{rmsw2}$ ) is

$$I_{rmsw2} \approx \sqrt{I_{pkw2}^2 \left(1 - \frac{V_{O1}}{V_{in(min)}}\right)} = \sqrt{0.128^2 \left(1 - \frac{3.3}{15}\right)} = 113 \text{ mA.} \quad (6)$$

The RMS current of W3 ( $I_{rmsw3}$ ) is

$$I_{rmsw3} \approx \sqrt{I_{pkw3}^2 \left(1 - \frac{V_{O1}}{V_{in(min)}}\right)} = \sqrt{0.128^2 \left(1 - \frac{3.3}{15}\right)} = 113 \text{ mA.} \quad (7)$$

The peak current of W1 ( $I_{pkw1}$ ) is

$$I_{pkw1} \approx IC I_{pk} + 3.4 (I_{pkw2} (I_{O2} + I_{O3}) + I_{pkw3} (I_{O4} + I_{O5})) \quad (8) = 2.38A + 3.4 (0.128(0.05+0.05) + (0.05+0.05)) = 2.6A.$$

This value is below the  $I_{CL(min)}$  specified in the LM2596 datasheet and thus is acceptable.

Since the current through W1 is continuous the RMS current is approximately equal to IC  $I_{pk}$  which is 2.38A.

###### b) Selection of C2 and C3

C2 and C3 should be selected to be large enough to smooth out the high ripple caused due to the flyback operation of W2 and W3. Also they should have a low enough ESR value. 47  $\mu$ H, 50V aluminum electrolytic capacitors are sufficient for this design.

###### c) Selection of D2 and D3

D2 and D3 should be selected to conduct the sum of the current through the two outputs each is connected to. The DC blocking voltage rating of D2 ( $V_{RD2}$ ) and D3 ( $V_{RD3}$ ) are calculated using equations (9) and (10).

$$V_{RD2} = (V_{in(max)} - V_{O1})N + V_{O2} \quad (9) = (40V - 3.3V) \times 3.4 + 12V = 137V.$$

$$V_{RD3} = (V_{in(max)} - V_{O1})N + V_{O3} \quad (10) = (40V - 3.3V) \times 3.4 + 12V = 137V.$$

1N459 diodes which have a reverse voltage rating of 175V are used in this design.

### **Step 3: Design of 3-Terminal Regulators**

The 3-terminal linear regulators are used to regulate the auxiliary outputs with  $\pm 5\%$  accuracy. Their design is straightforward and can be done using the datasheets for the 3-terminal regulators.

### **VI. Advantages**

This circuit can save both parts and cost by making use of only one step-down regulator IC, two inexpensive 3-terminal linear regulators, and a simple three-winding inductor to provide 5 outputs.

The usual solution for this design with multiple (positive and negative) outputs is a flyback converter. The design described in this application note is better than using a flyback regulator with multiple outputs because:

- It uses a much smaller output capacitor for the 3.3V output (270  $\mu\text{F}$  against 2.4 mF for flyback solution with a comparable output ripple voltage).
- It uses an inductor with only three windings whereas a flyback regulator solution requires a transformer with four windings.
- The overall peak current of the inductor in this design is less than that of a flyback transformer for the same application.
- Transformer construction is simplified because the leakage inductance does not result in power loss. Because of these reasons the magnetic structure of this design costs less than that in a flyback converter design.

- The peak switch current of this design is much less than that of a similar flyback design. The disadvantages of this design compared to the flyback converter are
- The 3.3V output should be loaded to keep the inductor in continuous conduction mode. Otherwise large peak currents result in the flyback windings. In worst cases (deep into discontinuous conduction mode), the auxiliary outputs ( $\pm 12\text{V}$  and  $\pm 5\text{V}$ ) will not be regulated.
- When the duty cycle of the main output gets large, large peak currents result in the flyback windings and may result in loss of regulation of the auxiliary outputs in worst cases.

In most applications the advantages far outweigh the disadvantages, as can be inferred from the comparison above.

The IC's used in this circuit are all available in surface mount packages.

### **VII. Summary**

In applications where multiple output DC/DC conversion is needed, the circuit presented in this application note is an attractive solution. It is low-cost, has a low-parts count, and provides the regulation needed with good efficiency. The detailed design procedure given in this application note makes this design easy and straightforward.

**LIFE SUPPORT POLICY**

NATIONAL'S PRODUCTS ARE NOT AUTHORIZED FOR USE AS CRITICAL COMPONENTS IN LIFE SUPPORT DEVICES OR SYSTEMS WITHOUT THE EXPRESS WRITTEN APPROVAL OF THE PRESIDENT OF NATIONAL SEMICONDUCTOR CORPORATION. As used herein:

1. Life support devices or systems are devices or systems which, (a) are intended for surgical implant into the body, or (b) support or sustain life, and whose failure to perform when properly used in accordance with instructions for use provided in the labeling, can be reasonably expected to result in a significant injury to the user.
2. A critical component is any component of a life support device or system whose failure to perform can be reasonably expected to cause the failure of the life support device or system, or to affect its safety or effectiveness.



**National Semiconductor Corporation**  
Americas  
Tel: 1-800-272-9959  
Fax: 1-800-737-7018  
Email: support@nsc.com

[www.national.com](http://www.national.com)

**National Semiconductor Europe**  
Fax: +49 (0) 1 80-530 85 86  
Email: europe.support@nsc.com  
Deutsch Tel: +49 (0) 1 80-530 85 85  
English Tel: +49 (0) 1 80-532 78 32  
Français Tel: +49 (0) 1 80-532 93 58  
Italiano Tel: +49 (0) 1 80-534 16 80

**National Semiconductor Asia Pacific Customer Response Group**  
Tel: 65-2544466  
Fax: 65-2504466  
Email: sea.support@nsc.com

**National Semiconductor Japan Ltd.**  
Tel: 81-3-5639-7560  
Fax: 81-3-5639-7507