

western peripherals™

Division of **WESPERCORP™**

MODEL TC-151 TAPE CONTROLLER
LOGIC MANUAL

PUBLICATION NUMBER

91000505

REV A

western peripherals

14321 MYFORD ROAD
TUSTIN, CALIFORNIA 92680

© 1981 by Western Peripherals, Inc.
All Rights Reserved

TABLE OF CONTENTS

| TITLE | |
|---|----------|
| Assembly Drawing, TC-151 Tape Controller | 60000619 |
| Assembly Drawing, TC-151 PE Adapter | 60000627 |
| Assembly Drawing, TC-151 Tape Controller | 60000866 |
| Assembly Drawing, TC-151 PE Adapter | 60000874 |
| Assembly, Cable, TC-151 PE BD Inter | 62000419 |
| Schematic, TC-151 Tape Controller | 75000547 |
| Schematic, TC-151 PE Adapter | 75000554 |
| Schematic, TC-151 Tape Controller | 75000778 |
| Schematic, TC-151 PE Adapter | 75000786 |
| LSI-11 Priority Jumper | 76000223 |
| PROM Set, TC-151, NRZ | 18001511 |
| PROM Set, TC-131/TC-151, PE | 18001321 |
| Modification Drawing, TC-151 Configuration "A" | 79000691 |
| Modification Drawing, TC-151N Configuration "A" | 79000717 |
| Modification Drawing, TC-151 Configuration "C" | 79000931 |
| Modification Drawing, TC-151N Configuration "D" | 79001194 |
| Notes | |
| Appendix A - Std Tape | |

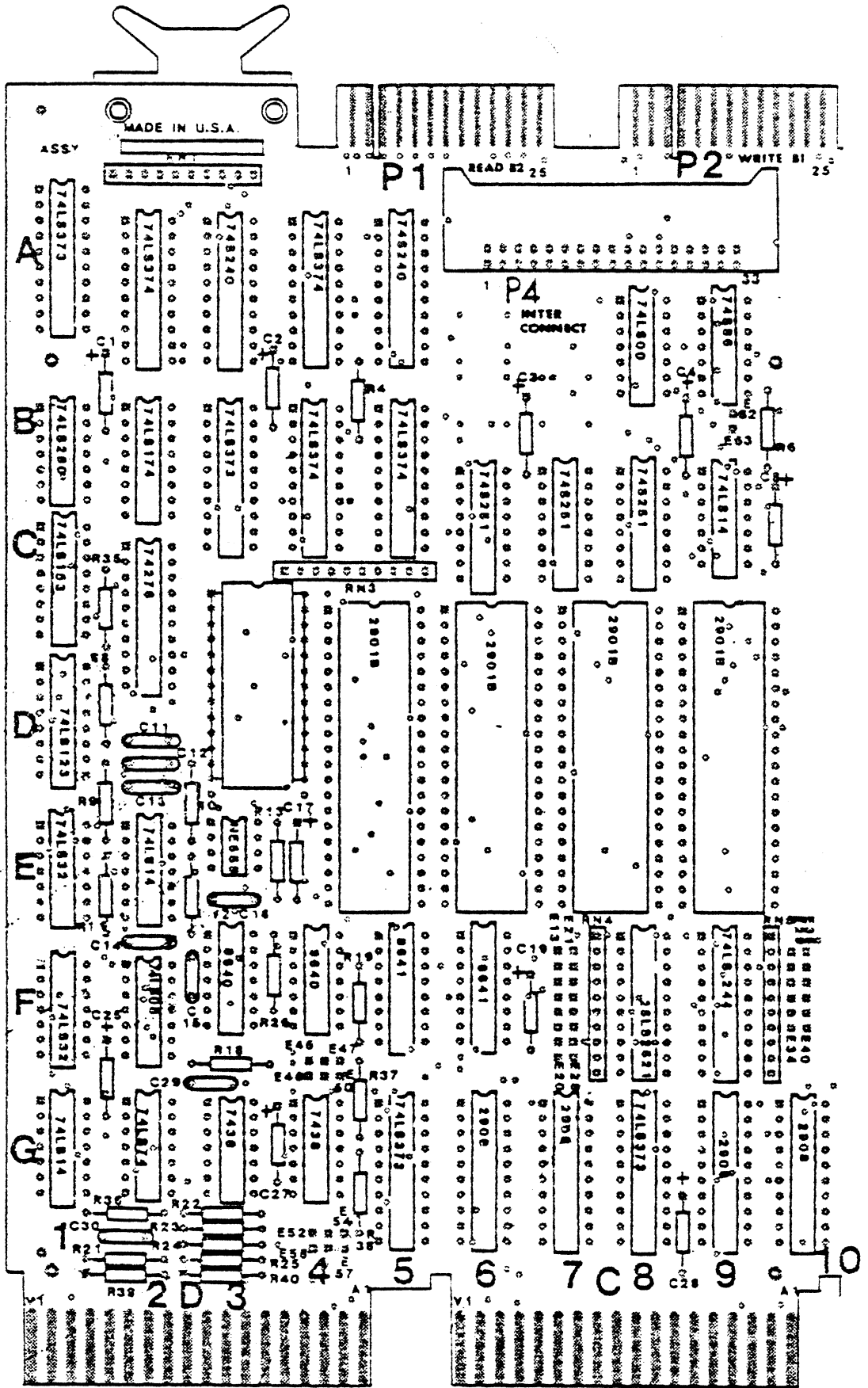

ASSEMBLY DRAWING, TC-151 TAPE CONTROLLER 60000619

LEFT HALF

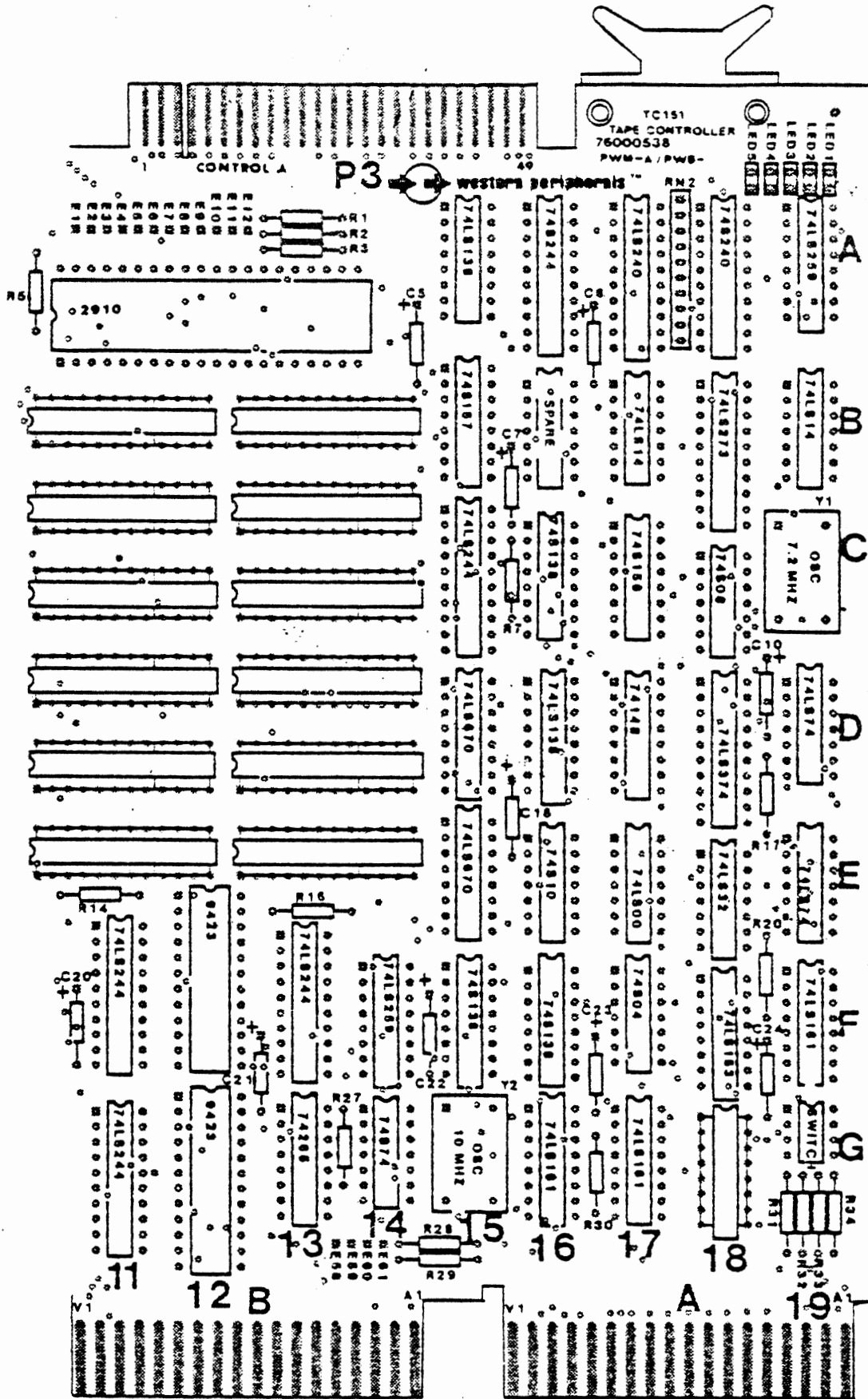

ASSEMBLY DRAWING, TC-151 TAPE CONTROLLER 60000619

RIGHT HALF

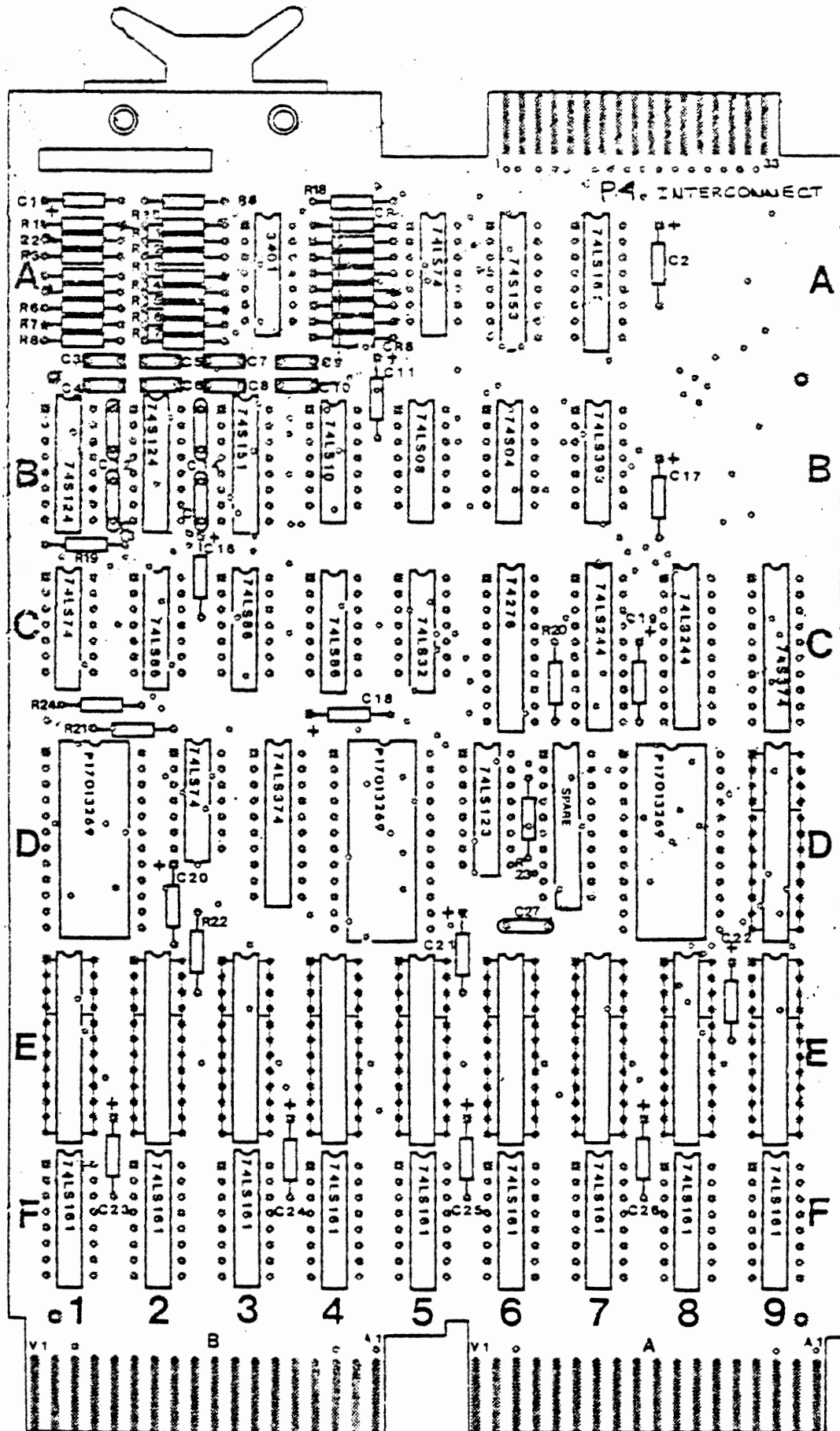

ASSEMBLY DRAWING, TC-151 PE ADAPTER 60000627

ASSY. NO.

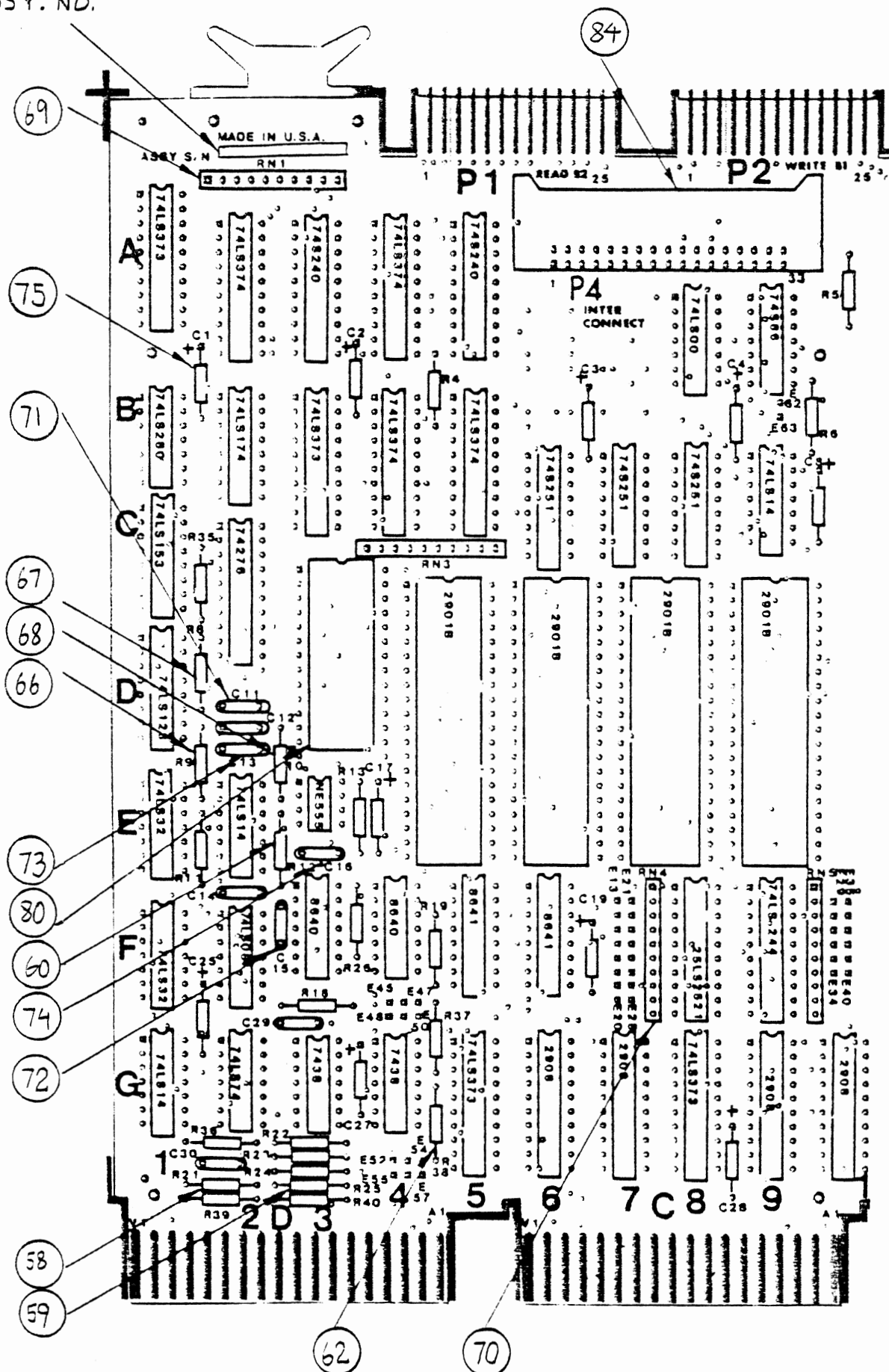

(LEFT HALF)

ASSEMBLY DRAWING TC-151 TAPE CTRLR.

60000866 D

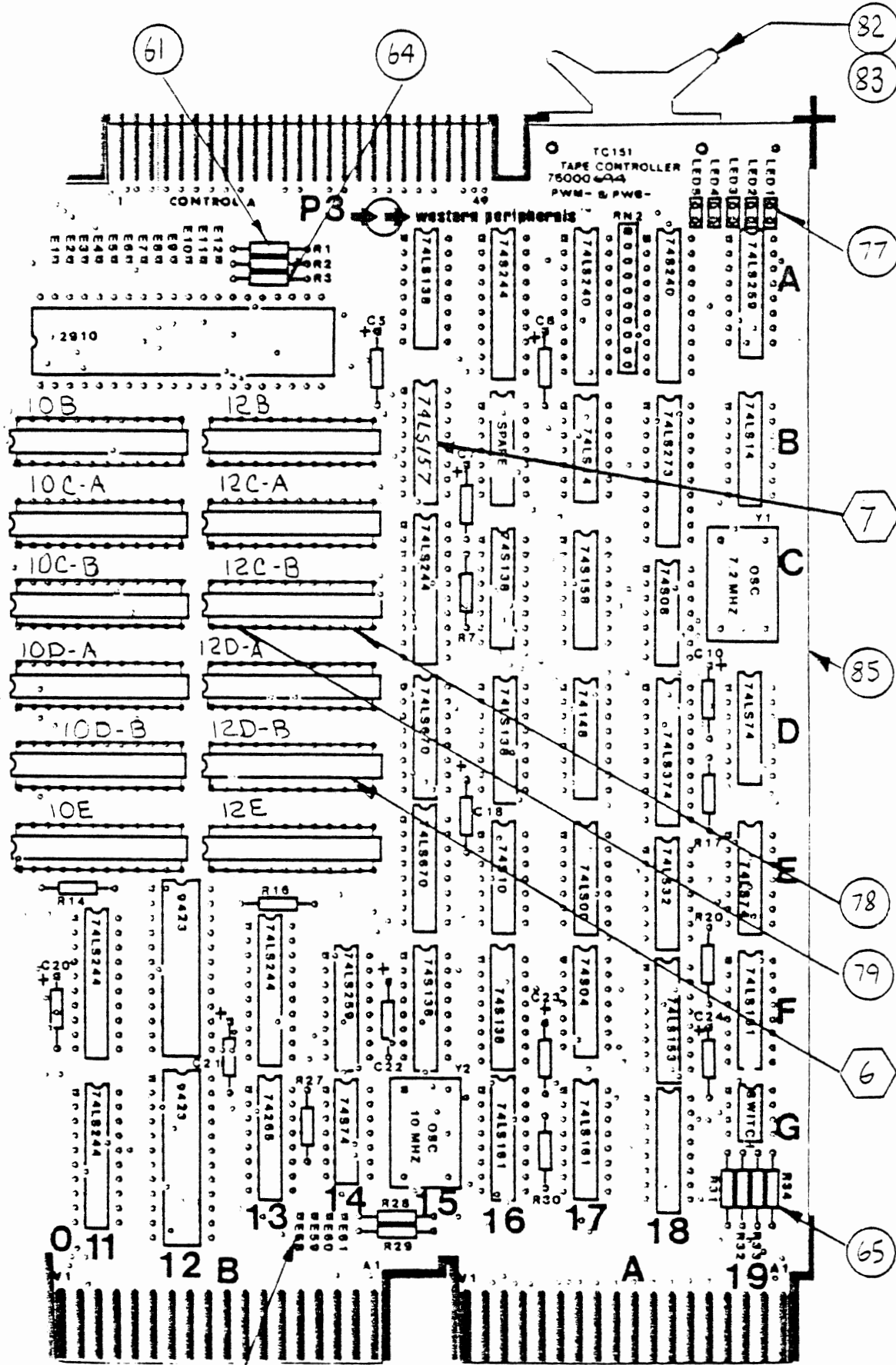

(RIGHT HALF)
 ASSEMBLY DRAWING TC-151 TAPE CTLR.
 60000866 D

CALL-OUT NOTES

4 PLCS (58)
R11 R16 R18 R21

4 PLCS (59)
R23 R25 R37 R40

R12 (60)

2 PLCS (61)
R1, R2

4 PLCS (62)
R22, R24, R38, R39

R9 (66)

R8 (67)

2 PLCS (68)
R10, R13

3 PLCS (69)
R11, R12, R13

2 PLCS (70)
R14, R15

2 PLCS (71)
C11, C12

4 PLCS (72)
C14, C15, C29, C30

C13 (73)

C16 (74)

20 PLCS (75)
C1-C8, C10, C17-C25, C27, C28

3C (80)

63 PLCS (81)
E1-E40 E45-E50
E52-E68

P4 (84)

(64) 11 PLCS
R3, R4, R7, R14, R17, R20,
R27-R30, R35

(65) 9 PLCS
R5, R6, R19, R26,
R31-R34, R36

(77) 5 PLCS
LED1-LED5

(78) 12 PLCS
10B, 10C-A, 10C-B, 10D-A, 10D-B, 10E
12B, 12C-A, 12C-B, 12D-A, 12D-B, 12E

(79) 13 PLCS
10B, 10C-A, 10C-B, 10D-A,
10D-B, 10E, 12B, 12C-A, 12C-B,
12D-A, 12D-B, 12E, 18G

(82) 2 PLCS

(83) 4 PLCS

(85)

6 REF. PROM 12D-B IS P17017609-C

7 SILKSCREEN WRONG, INSTALL
74LS157 AS SHOWN

REF SCHEMATIC 75000778

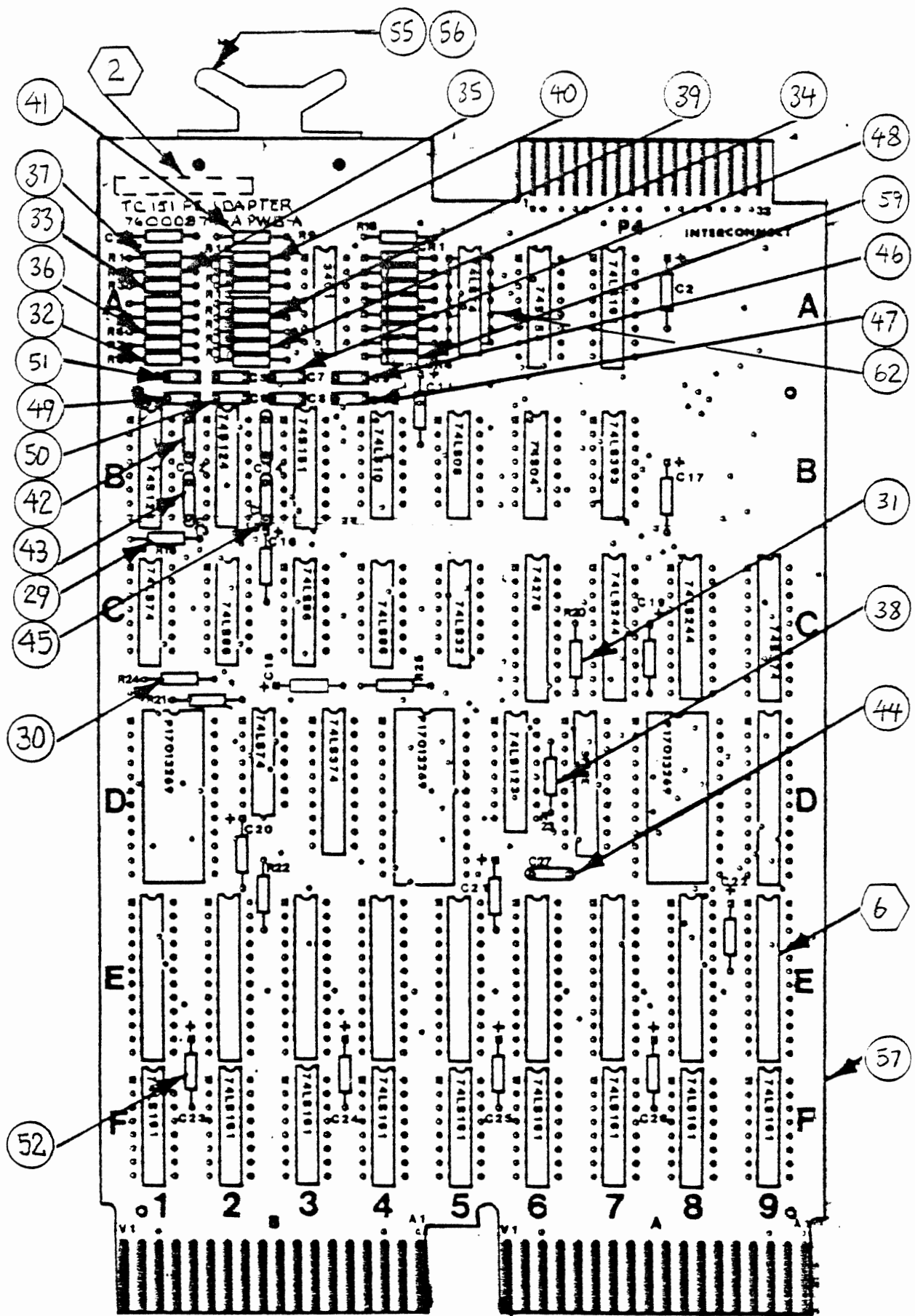

ASSEMBLY DWG TC-151 PE ADAPTER
60000874 C

NOTES

- ② ASSEMBLY NUMBER
- REF. SCHEMATIC 75000786
- ⑥ INSTALL PROMS 1E-9E & 9D PER PROM SET P18001321

- 29 R24
- 30 R19
- 31 4 PLCS R18, R20, R21, R22
- 32 R4, R8, R17 - 3 PLCS
- 33 R3
- 34 2 PLCS - R7, R16
- 35 R2
- 36 2 PLCS - R6, R15
- 37 R1, R25 - 2 PLCS
- 38 R23
- 39 2 PLCS R5, R14
- 40 4 PLCS. R10-R13
- 41 R9
- 42 C12
- 43 C13
- 44 2 PLCS - C14, C27
- 45 C15
- 46 C9
- 47 2 PLCS - C8, C10
- 48 C7
- 49 C4
- 50 2 PLCS - C5, C6
- 51 C3
- 52 14 PLCS - C1, C2, C11, C16-C26
- 55
- 56 2 PLCS.
- 57
- 59 8 PLCS CRI-CRB
- 62

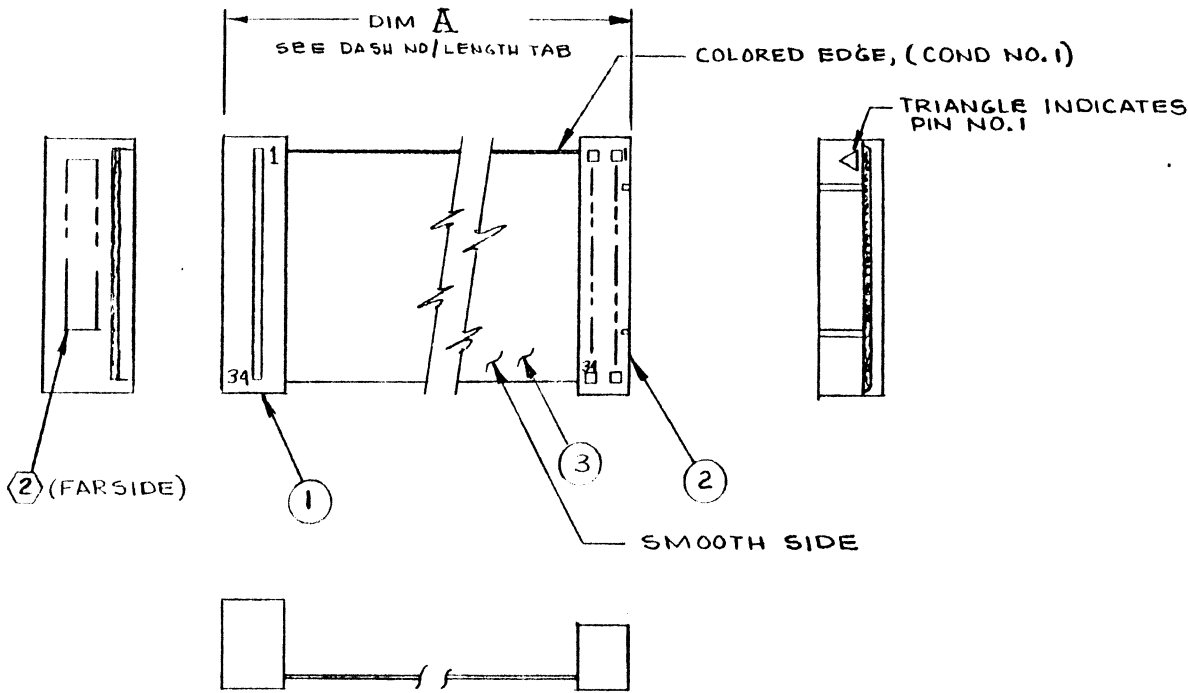

| REVISIONS | | | |
|-----------|--------------------|---------|-------------|
| LTR | DESCRIPTION | DATE | APPROVED |
| A | PRODUCTION RELEASE | 12/1/80 | [Signature] |

| CABLE DASH NO./LENGTH TABULATION | | |
|----------------------------------|--------------------|-------------------|
| DASH NO. | DIM. A (IN INCHES) | REMARKS |
| -00 | 2.50 ± .12 | BOARD TO BOARD |
| -01 | 11.50 ± .25 | BOARD TO EXTENDER |

DEC 5 1980

NOTE: UNLESS OTHERWISE SPECIFIED.
 1. FOR MATERIAL SEE P/L 62000419
 2. MARK PART NUMBER, DASH NUMBER AND LATEST REV LTR WHERE SHOWN USING CONTRASTING INK

THIS IS A TABULATED DRAWING SEE TAB. ABOVE

| | | | |
|--|--|---|---------------------------------------|
| TOLERANCES UNLESS OTHERWISE SPECIFIED FRACTIONS DEC ANGLES ± / ± / ± / | | western peripherals™ TUSTIN, CALIFORNIA | |
| APPROVALS | | | |
| DRAWN COPUM | | 12-2-80 | ASSY, CABLE, TC 151 P.E. BD INTER. |
| CHECKED S. HARRIS | | 12-2-80 | |
| | | SCALE NONE | SIZE B |
| | | DRAWING NO. 62000419 | |
| DO NOT SCALE DRAWING | | | SHEET 1 OF 1 |

TABLE OF CONTENTS

TC-151 SCHEMATIC

| <u>CPU BUS</u> | <u>PAGE</u> |
|------------------------------|-------------|
| CPU Bus Transceivers | 1 |
| TM-11 Address Detector | |
| Data Latch | |
| | |
| CPU Vector Jumpers and Gate | 2 |
| Bus Signal Receiver | |
| Reset Logic | |
| PIO Address Latch | |
| | |
| PLA Bus Sequencer | 3 |
| NXM Timer/Latch | |
| Control Line Drivers | |
| | |
| Bus-Master Control | 4 |
| Bus Priority Logic | |
| | |
| <u>DATA PROCESSOR</u> | |
| 2901 Data Processor | 5 |
| Write Byte Control | |
| | |
| Literal Gate | 6 |
| Control Pulse Decoder | |
| Destination Decoder | |
| Source Decoder | |
| Indicator LED's | |
| "A" Latch | |
| "B" Latch | |
| | |
| <u>ADDRESS PROCESSOR</u> | |
| Condition Test Registers | 7 |
| Condition Test Select | |
| D-Bus Test Select | |
| Micro-Interrupt Vector RAM's | |

TABLE OF CONTENTS (CONTINUED)

| <u>TITLE</u> | <u>PAGE</u> |
|---------------------------------------|-------------|
| Micro-Interrupt Control | 8 |
| 2910 Instruction Multiplexer | 9 |
| 2910 Program Address Processor | |
| PIO Vector Gate | |
| Timer Bit Generator | 10 |
| Controller Clock Generator | |
| Data Buffer FIFO (P/O Data Processor) | |
| Control Store ROM's (0-511) | 11 |
| Control Store ROM's (512-1023) | 12 |
| <u>TAPE INTERFACE</u> | |
| Tape Write Clock Generator | 13 |
| Tape Unit Command Register & Driver | 14 |
| Unit Select Decoder & Driver | |
| Write Data Register & Driver | |
| Tape Status Terminator & Gate | 15 |
| Tape Unit Select Register | |
| Parity Generator & Control | |
| PE Parity Gate | |
| NRZI Read Register | 16 |
| Tape Control & Status | |
| Read Line Terminators | |
| Read Strobe Interrupt | |

TABLE OF CONTENTS (CONTINUED)

| <u>PE READ BOARD</u> | <u>PAGE</u> |
|---------------------------------------|-------------|
| PE Data Gate | 1 |
| PE Drop-Out Gate | |
| PE Parity Control | |
| PE Status RDM | |
| PE Status Latch | |
| | |
| PE Reference Divider | 2 |
| PE Phase Comparator | |
| PE Read Activity Detector and Control | |
| | |
| PE Voltage Controlled Oscillators | 3 |
| PE Clock Selector | |
| | |
| PE Read Register | 4-6 |
| PE Window Counter | |
| PE Deskew Register | |
| | |
| PE Sequencer ROM's | 7-9 |
| | |
| PE Deskew Buffer Timer | 7 |

CONTROL A

| | P3 | | |
|------|----|----|-----|
| SLT6 | 1 | 2 | GND |
| SLT7 | 3 | 4 | GND |
| SLT5 | 5 | 6 | GND |
| SLT4 | 7 | 8 | GND |
| SLT3 | 9 | 10 | GND |
| SLT0 | 11 | 12 | GND |
| SLT1 | 13 | 14 | GND |
| SLT2 | 15 | 16 | GND |
| FLPT | 17 | 18 | GND |
| WNB | 19 | 20 | GND |
| OVW | 21 | 22 | GND |
| RSL | 23 | 24 | GND |
| EOT | 25 | 26 | GND |
| RWC | 27 | 28 | GND |
| DDS | 29 | 30 | GND |
| EOTP | 31 | 32 | GND |
| FSL | 33 | 34 | GND |
| +5V | 35 | 36 | GND |
| +5V | 37 | 38 | GND |
| RW6 | 39 | 40 | GND |
| RDY | 41 | 42 | GND |
| OML | 43 | 44 | GND |
| | 45 | 46 | GND |
| SPD | 47 | 48 | GND |
| NRZ | 49 | 50 | GND |

WRITE B1

| | P2 | | |
|------|----|----|-----|
| WD5 | 1 | 2 | GND |
| WD7 | 3 | 4 | GND |
| WARS | 5 | 6 | GND |
| WD6 | 7 | 8 | GND |
| | 9 | 10 | GND |
| WD5 | 11 | 12 | GND |
| WDP | 13 | 14 | GND |
| WD4 | 15 | 16 | GND |
| WDO | 17 | 18 | GND |
| WD3 | 19 | 20 | GND |
| WDI | 21 | 22 | GND |
| WD2 | 23 | 24 | GND |
| +5V | 25 | 26 | GND |

INTERCONNECT

| | P4 | | |
|--------|----|----|---------|
| DBUS01 | 1 | 2 | DBUS00 |
| DBUS03 | 3 | 4 | DBUS02 |
| DBUS06 | 5 | 6 | DBUS07 |
| DBUS05 | 7 | 8 | DBUS04 |
| GND | 9 | 10 | GND |
| | 11 | 12 | PEP |
| FWD | 13 | 14 | RD7 |
| RD6 | 15 | 16 | RD5 |
| RD4 | 17 | 18 | RD3 |
| RD2 | 19 | 20 | RDI |
| RDO | 21 | 22 | RDP |
| PEDATA | 23 | 24 | RGATE |
| PERDY | 25 | 26 | PEDO |
| SO | 27 | 28 | PESTAT |
| CKSEL4 | 29 | 30 | CKSEL1 |
| CKSEL2 | 31 | 32 | CHARCLK |
| GND | 33 | 34 | LIPCLK |

READ B2

| | P1 | | |
|-----|----|----|-----|
| RD7 | 1 | 2 | GND |
| RD6 | 3 | 4 | GND |
| RD5 | 5 | 6 | GND |
| RD4 | 7 | 8 | GND |
| RD3 | 9 | 10 | GND |
| RD2 | 11 | 12 | GND |
| RDI | 13 | 14 | GND |
| NRZ | 15 | 16 | GND |
| | 17 | 18 | GND |
| RDO | 19 | 20 | GND |
| RDS | 21 | 22 | GND |
| RDP | 23 | 24 | GND |
| | 25 | 26 | GND |

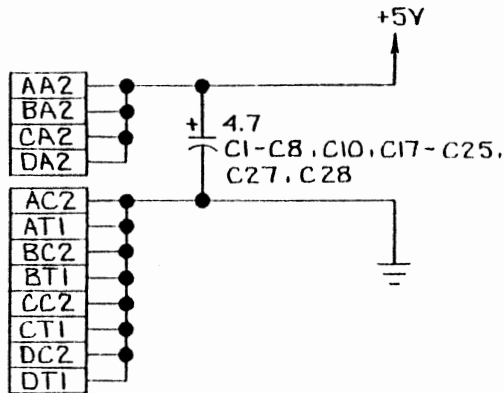

| LAST DESIGNATION USED | |
|-----------------------|------|
| RESISTOR | R40 |
| CAPACITOR | C30 |
| OSCILLATOR | Y2 |
| LIGHT EMITTING DIODE | LED5 |
| RESISTOR NETWORK | RM5 |

REFERENCE DESIGNATIONS NOT USED:
 R15
 C9
 E26
 E41-E44
 E51

| REVISIONS | | | |
|-----------|--------------------------------|---------|--------------------|
| LTR | DESCRIPTION | DATE | APPROVED |
| A | RELEASE TO PRODUCTION | 2-27-81 | <i>[Signature]</i> |
| B | REVISED SHTS ④⑦ PER E.C.O. 865 | 3-12-81 | <i>[Signature]</i> |
| C | REV. SHTS ③④ PER E.C.O. 865 | 4-23-81 | <i>[Signature]</i> |

- ⑧ FOR TEST ONLY.
 - ⑦ SEE SPEED SETTING TABLE.
 - ⑥ SEE INTERRUPT PRIORITY LEVEL TABLE.
 - ⑤ SEE INTERRUPT VECTOR TABLE.
 - ④ SEE DEVICE ADDRESS TABLE.
 - 3. REFERENCE ASSY. 60000619.
 - 2. CAPACITOR VALUES ARE IN MICROFARADS.
 - 1. RESISTANCE VALUES ARE IN OHMS.
- NOTES: UNLESS OTHERWISE SPECIFIED

| | | | |
|---------------------------------------|-----------|--|---|
| TOLERANCES UNLESS OTHERWISE SPECIFIED | | western peripherals™ TUSTIN, CALIFORNIA | |
| FRACTIONS | DEC. | | |
| ± | ± | ± | SCHEMATIC TC 151 TAPE CONTROLLER |
| APPROVALS | DATE | SCALE | |
| DRAWN <i>C. Ispoda</i> | 12-17-80 | SIZE | |
| CHECKED <i>[Signature]</i> | 12-15-80 | DRAWING NO. | |
| | 12 Dec 80 | B | 75000547 |
| DO NOT SCALE DRAWING | | | SHEET 1 OF 18 |

| REVISIONS | | | |
|-----------|-------------|------|----------|
| LTR | DESCRIPTION | DATE | APPROVED |

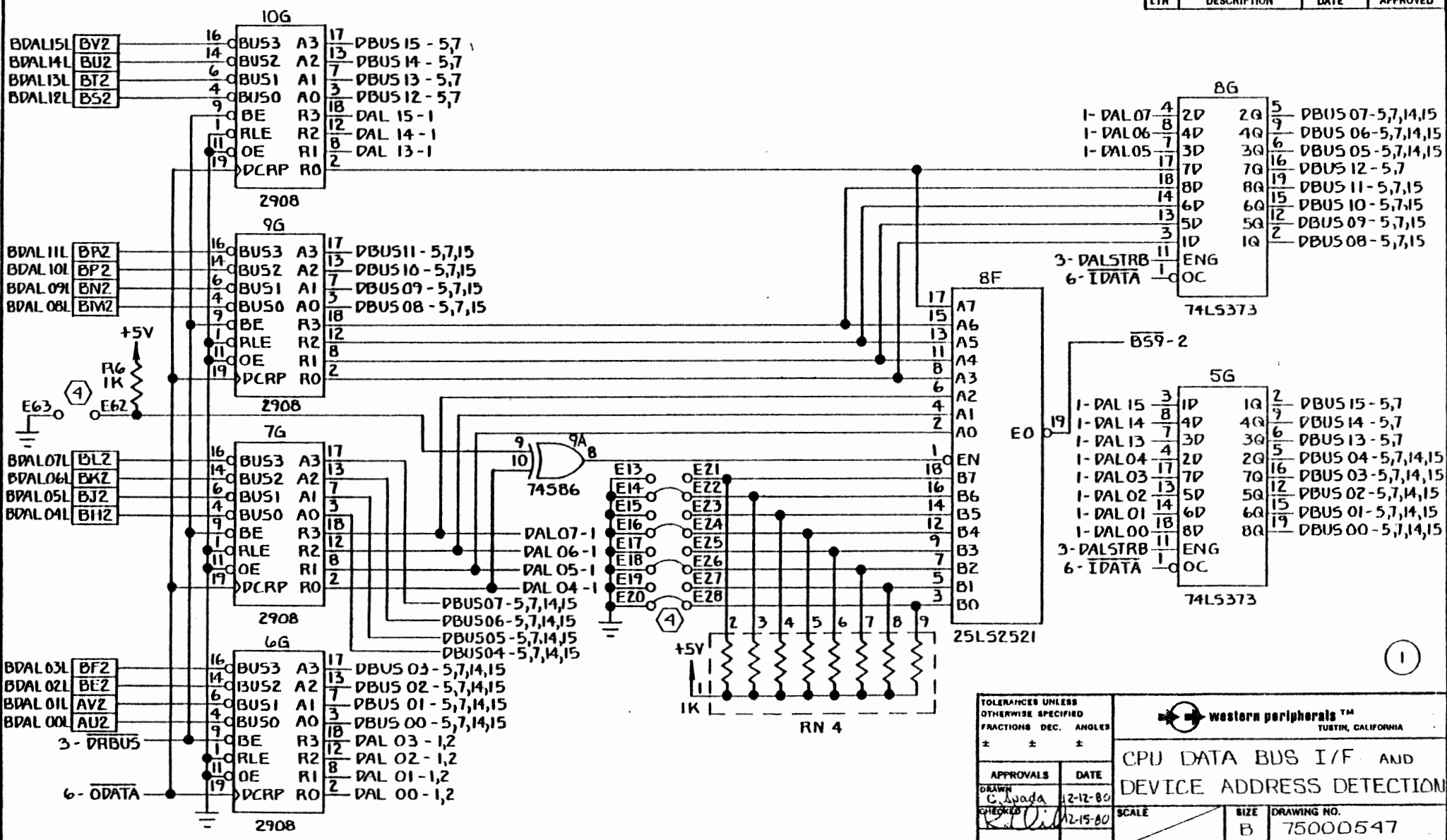

| | | | |
|---------------------------------------|----------|--|-------------------------|
| TOLERANCES UNLESS OTHERWISE SPECIFIED | | western peripherals™ TUSTIN, CALIFORNIA | |
| FRACTIONS DEC. ANGLES | | CPU DATA BUS I/F AND | |
| ± ± ± | | DEVICE ADDRESS DETECTION | |
| APPROVALS | DATE | SCALE | SIZE |
| DRAWN C. Canada | 12-12-80 | | B |
| CHECKED R. L. L. | 12-15-80 | | DRAWING NO. 75000547 |
| DO NOT SCALE DRAWING | | | SHEET 2 OF 18 |

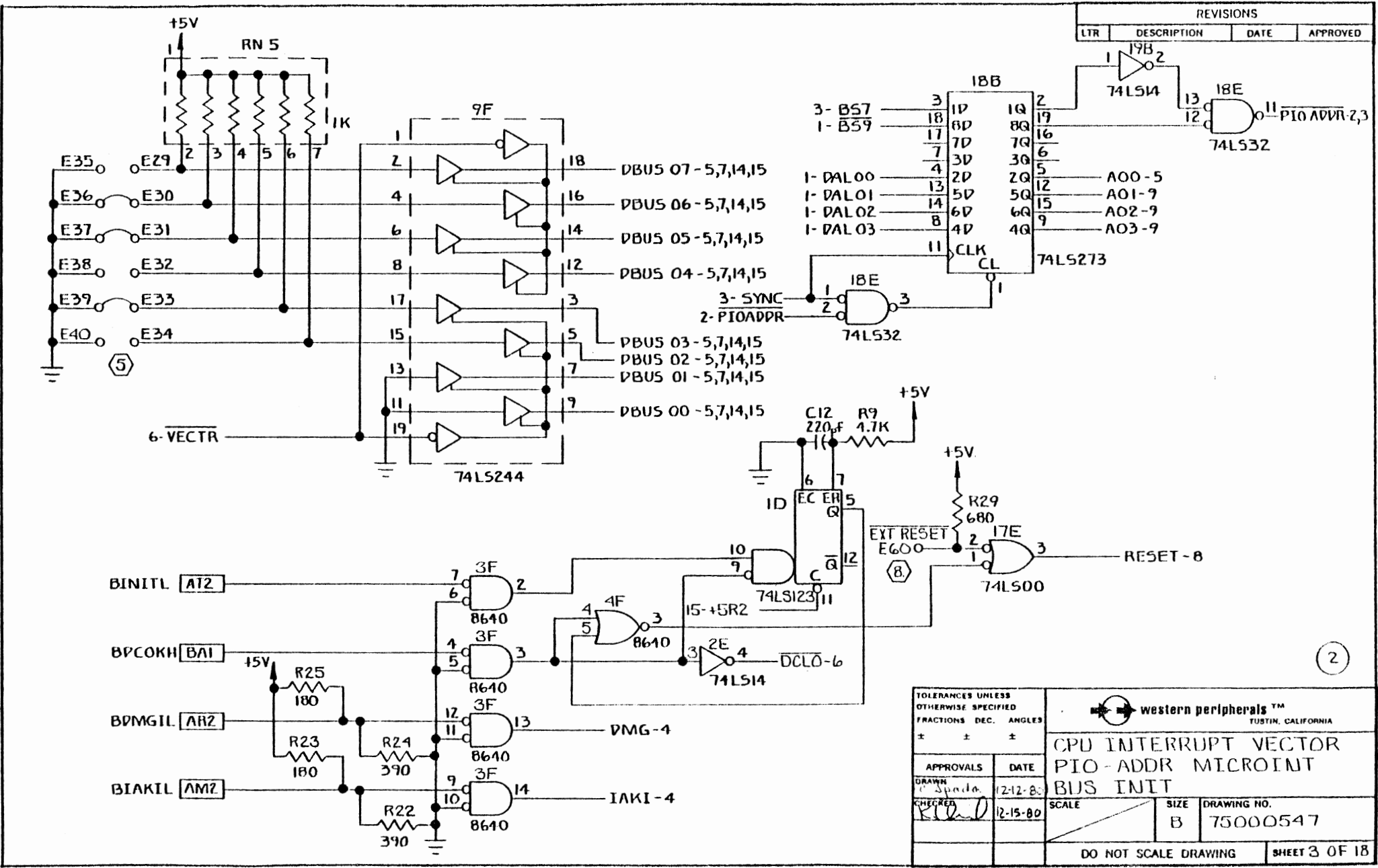

| REVISIONS | | | |
|-----------|-------------|------|----------|
| LTR | DESCRIPTION | DATE | APPROVED |
| | | | |

| | |
|---------------------------------------|----------|
| TOLERANCES UNLESS OTHERWISE SPECIFIED | |
| FRACTIONS DEC. ANGLES | ± ± ± |
| APPROVALS | DATE |
| DRAWN <i>[Signature]</i> | 12-12-80 |
| CHECKED <i>[Signature]</i> | 12-15-80 |

| | | | |
|--|------|-------------|---------------|
| western peripherals™ TUSTIN, CALIFORNIA | | | |
| CPU INTERRUPT VECTOR PIO-ADDR MICROINT BUS INIT | | | |
| SCALE | SIZE | DRAWING NO. | |
| | B | 75000547 | |
| DO NOT SCALE DRAWING | | | SHEET 3 OF 18 |

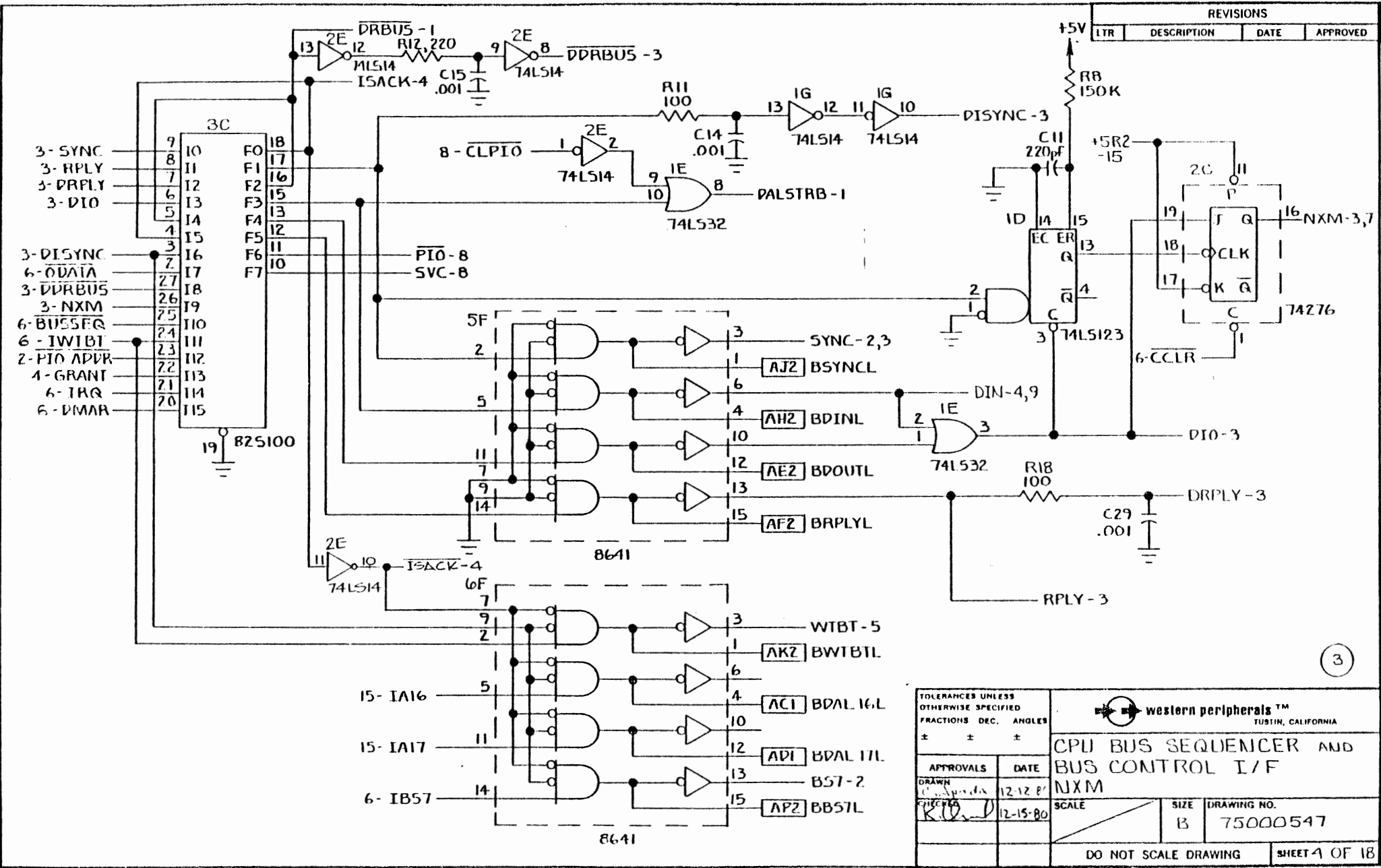

| REVISIONS | | | |
|-----------|-------------|------|----------|
| LTR | DESCRIPTION | DATE | APPROVED |
| | | | |

(3)

| | | | |
|--|----------|---|---|
| TOLERANCES UNLESS OTHERWISE SPECIFIED | | western peripherals™ TUSTIN, CALIFORNIA | |
| FRACTIONS | DEC. | ANGLES | CPU BUS SEQUENCER AND BUS CONTROL I/F NXM |
| ± | ± | ± | |
| APPROVALS | DATE | SCALE | SIZE |
| DRAWN <i>[Signature]</i> CHECKED <i>[Signature]</i> | 12-12-80 | | B |
| DRAWING NO. | | 75000547 | |
| DO NOT SCALE DRAWING | | | SHEET 4 OF 18 |

| REVISIONS | | | |
|-----------|-------------|------|----------|
| LTR | DESCRIPTION | DATE | APPROVED |

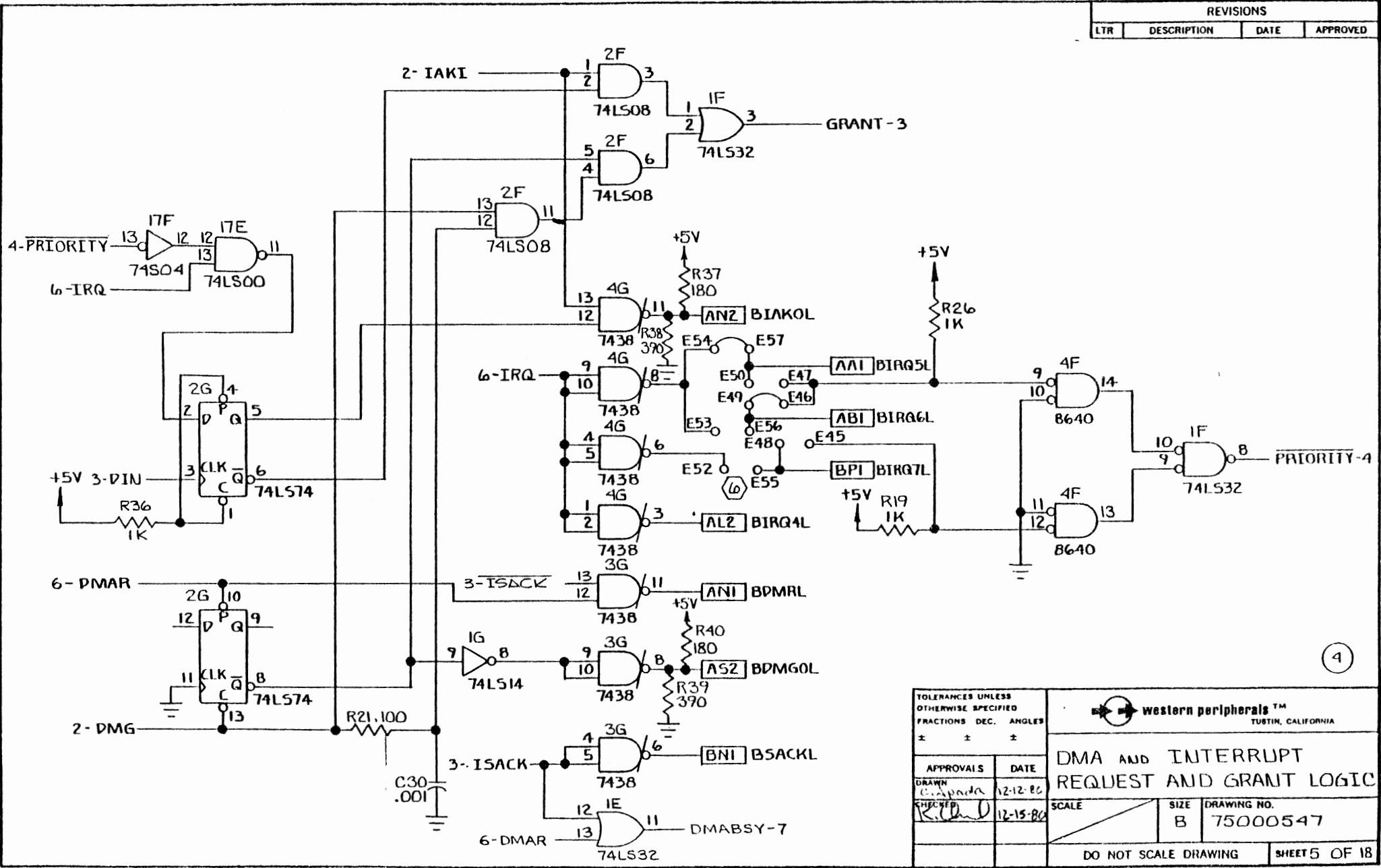

| | | | |
|---|----------|--|-----------|
| TOLERANCES UNLESS OTHERWISE SPECIFIED FRACTIONS DEC. ANGLES ± ± ± | | western peripherals™ TUSTIN, CALIFORNIA | |
| APPROVALS | DATE | DMA AND INTERRUPT REQUEST AND GRANT LOGIC | |
| DRAWN <i>C. Spada</i> | 12-12-80 | SCALE | SIZE B |
| CHECKED <i>R. D.</i> | 12-15-80 | DRAWING NO. 75000547 | |
| DO NOT SCALE DRAWING | | SHEET 5 OF 18 | |

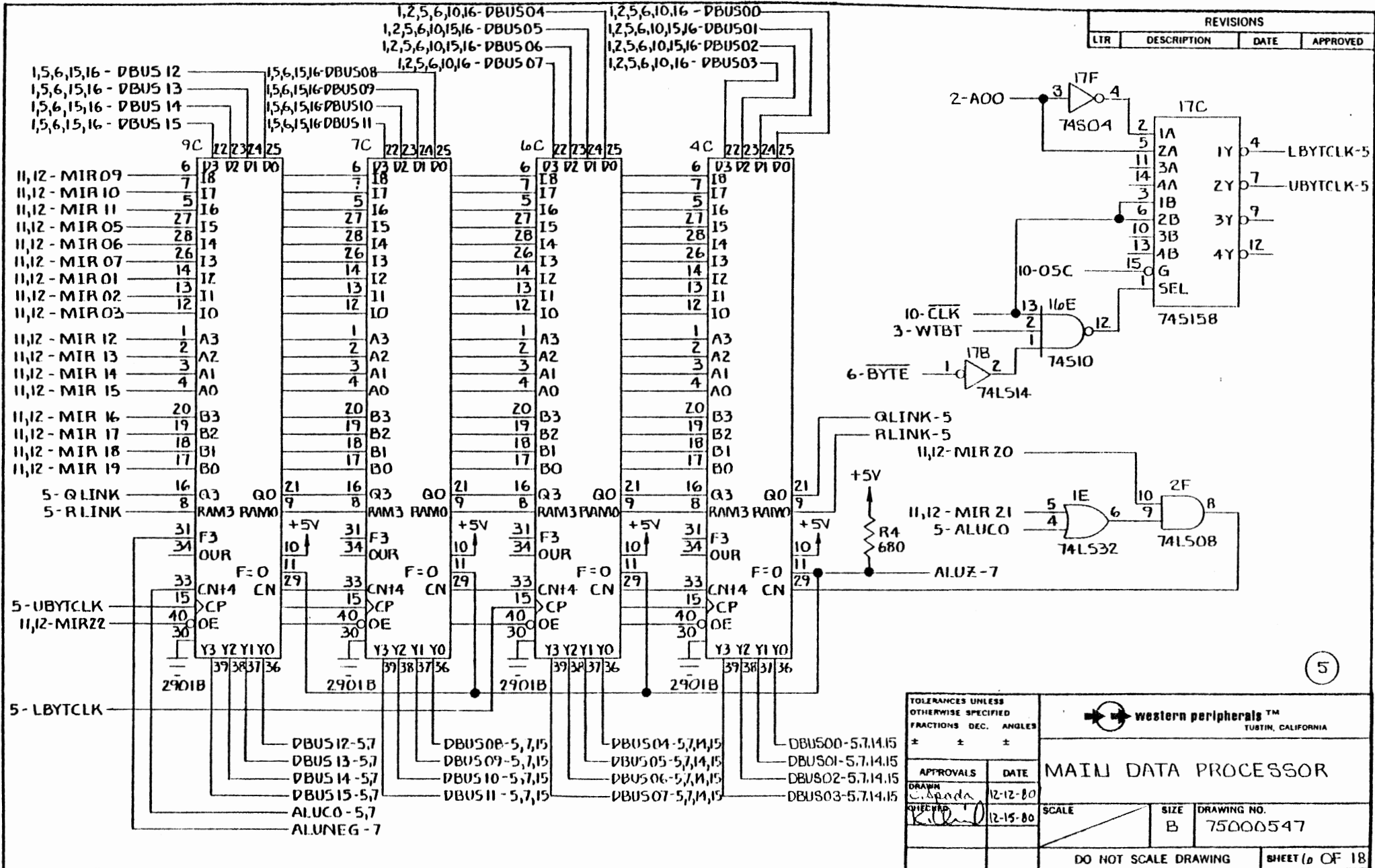

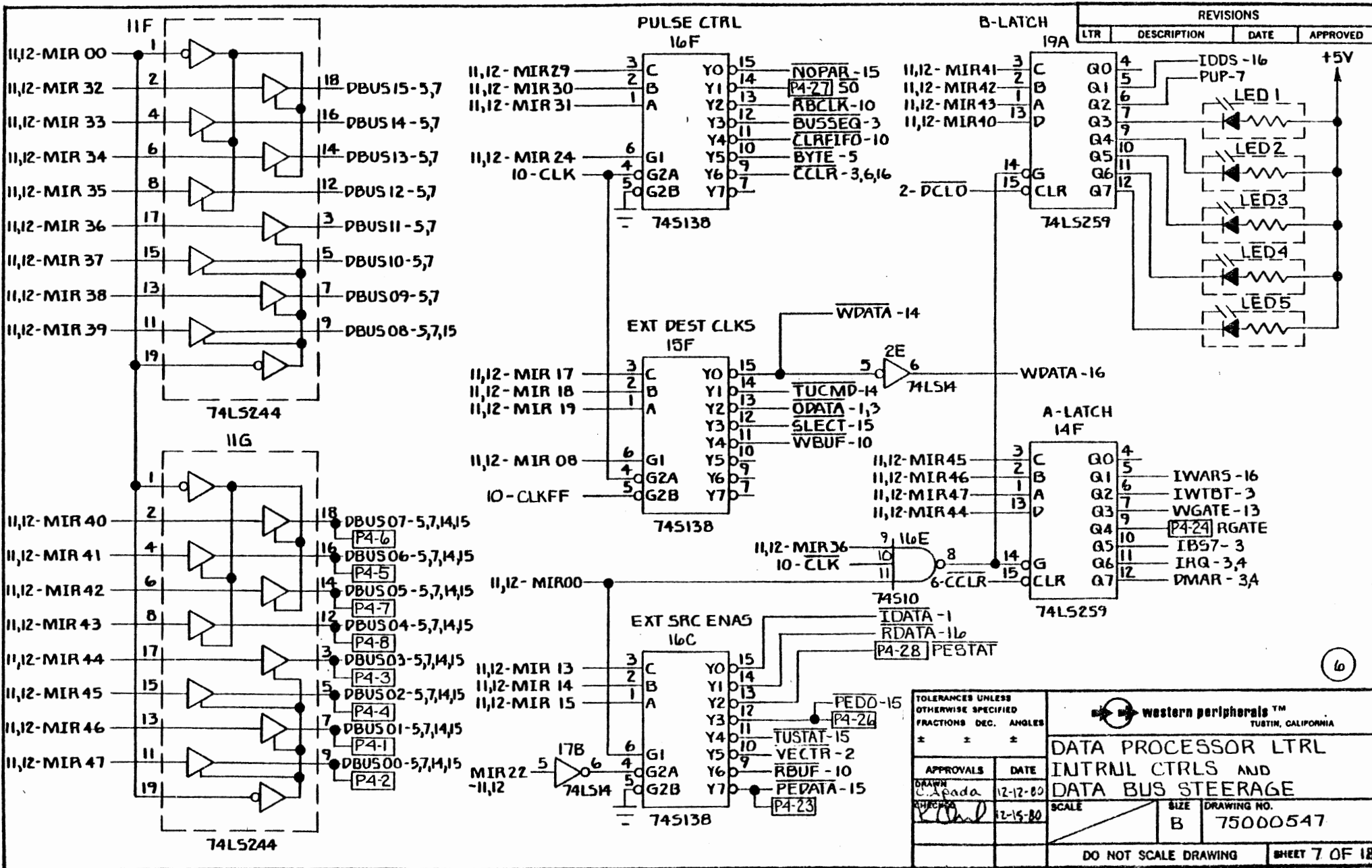

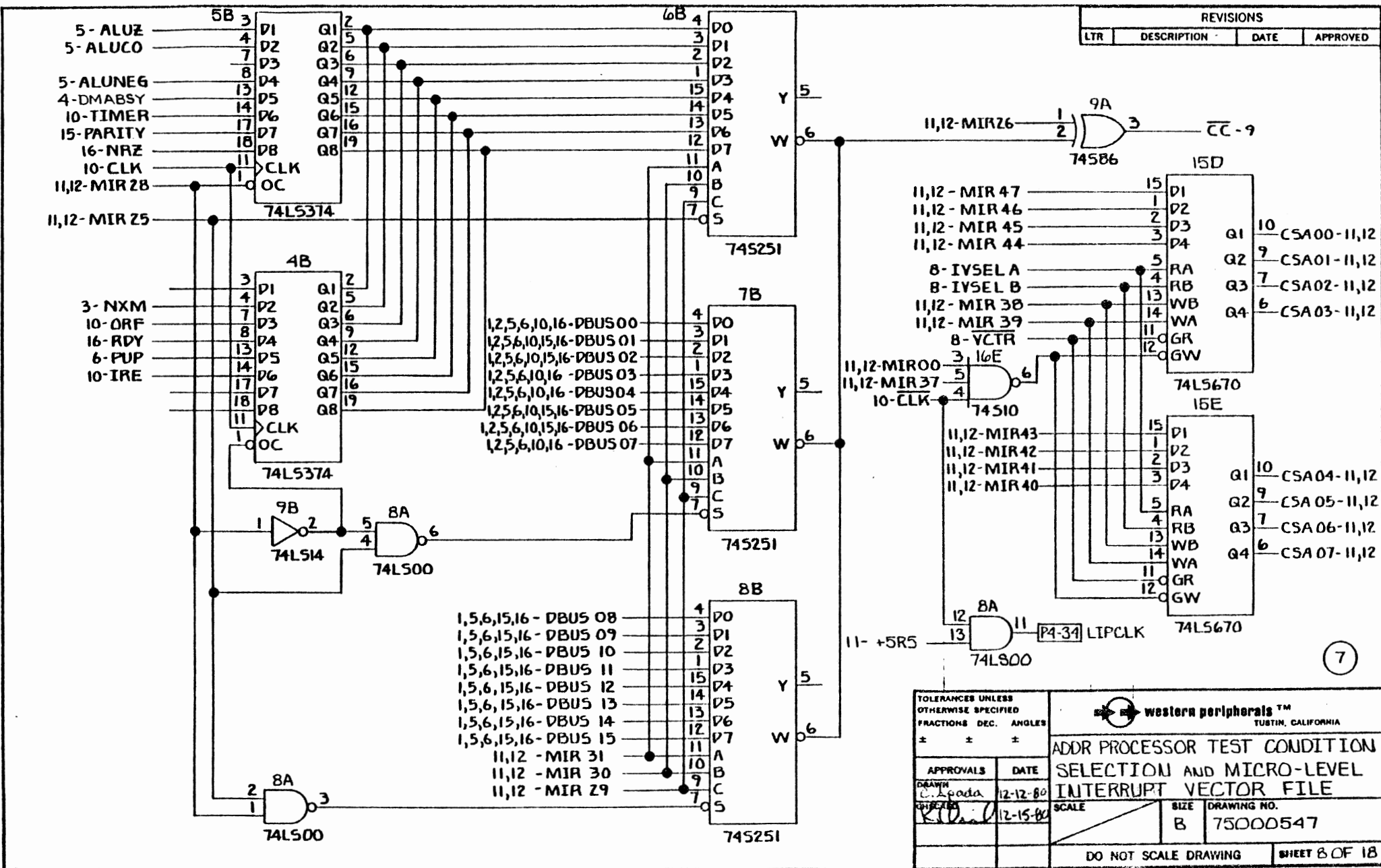

| REVISIONS | | | |
|-----------|-------------|------|----------|
| LTR | DESCRIPTION | DATE | APPROVED |
| | | | |

| | | | |
|--|--------------------------|--|--------------------------------------|
| TOLERANCES UNLESS OTHERWISE SPECIFIED FRACTIONS DEC. ANGLES | | western peripherals™ TUSTIN, CALIFORNIA | |
| APPROVALS | DATE | ADDR PROCESSOR TEST CONDITION SELECTION AND MICRO-LEVEL INTERRUPT VECTOR FILE | |
| DRAWN <i>C. Leada</i> CHECKED <i>R. De...</i> | 12-12-80 12-15-80 | SCALE | SIZE B DRAWING NO. 75000547 |
| DO NOT SCALE DRAWING | | SHEET 8 OF 18 | |

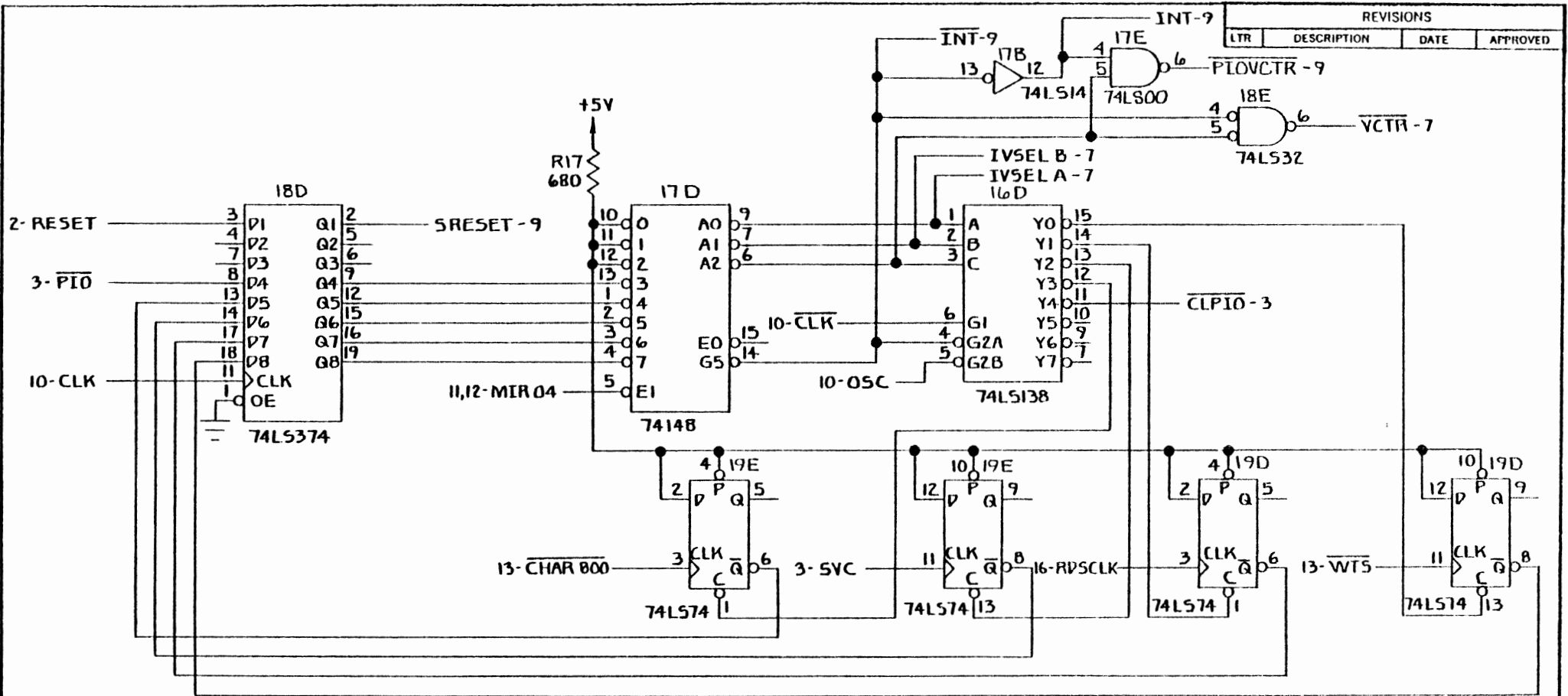

| REVISIONS | | | |
|-----------|-------------|------|----------|
| LTR | DESCRIPTION | DATE | APPROVED |
| | | | |

(8)

TOLERANCES UNLESS OTHERWISE SPECIFIED
 FRACTIONS DEC. ANGLES
 ± ± ±

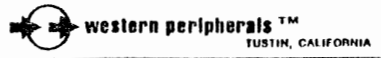

| | |
|-------------------|----------|
| APPROVALS | DATE |
| DRAWN C. Spada | 12-12-80 |
| CHECKED R. D. | 12-15-80 |

MICRO-LEVEL INTERRUPT CTRL

| | | |
|-------|-----------|-------------------------|
| SCALE | SIZE B | DRAWING NO. 75000547 |
|-------|-----------|-------------------------|

DO NOT SCALE DRAWING SHEET 9 OF 18

| REVISIONS | | | |
|-----------|-------------|------|----------|
| LTR | DESCRIPTION | DATE | APPROVED |

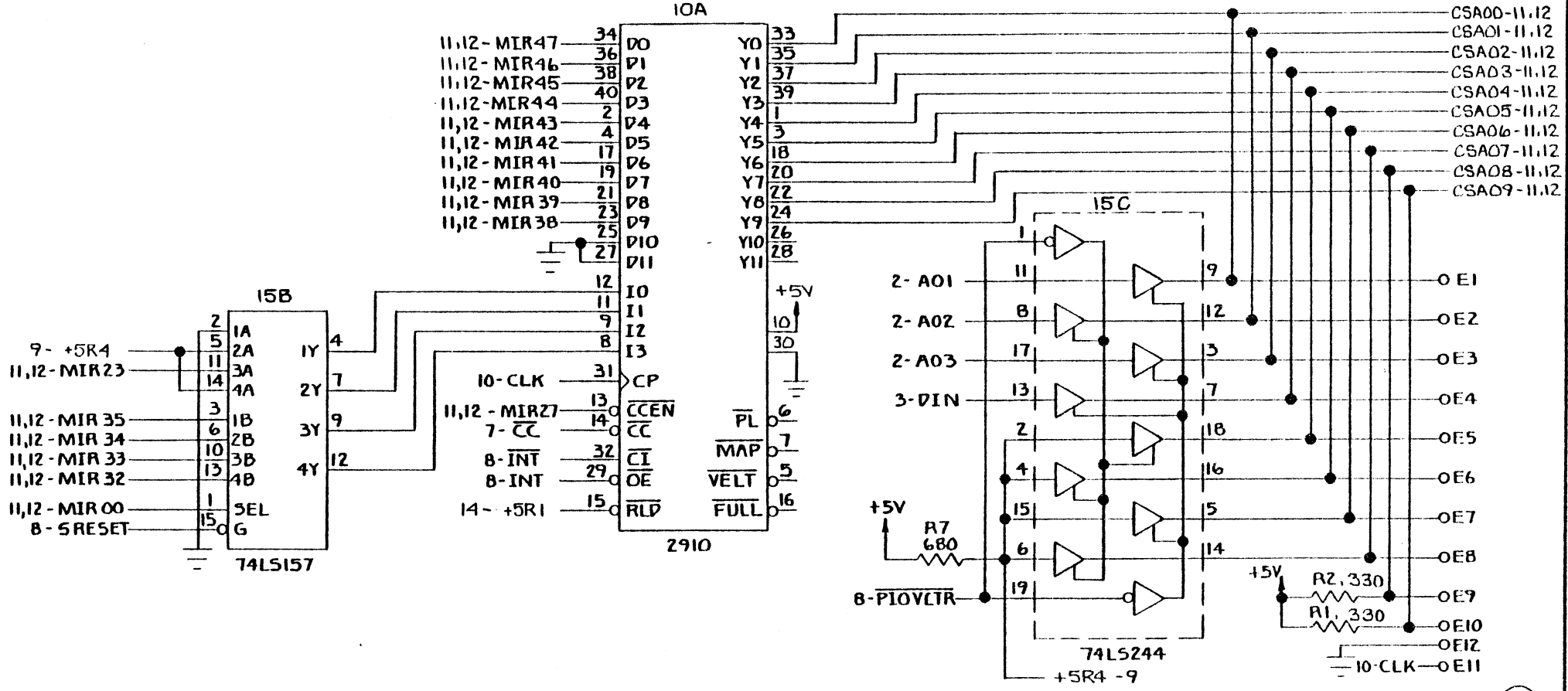

| | | | |
|--|--|--|-------------|
| | | | CSA00-11.12 |
| | | | CSA01-11.12 |
| | | | CSA02-11.12 |
| | | | CSA03-11.12 |
| | | | CSA04-11.12 |
| | | | CSA05-11.12 |
| | | | CSA06-11.12 |
| | | | CSA07-11.12 |
| | | | CSA08-11.12 |
| | | | CSA09-11.12 |

9

| | | | |
|---|--------------------------|--|--------------------------------------|
| TOLERANCES UNLESS OTHERWISE SPECIFIED FRACTIONS DEC. ANGLES ± ± ± | | western peripherals™ TUSTIN, CALIFORNIA | |
| APPROVALS | DATE | ADDR PROCESSOR | |
| DRAWN C. Apada CHECKED R. [Signature] | 12.12.80 12.15.80 | SCALE | SIZE B DRAWING NO. 75000547 |
| | | DO NOT SCALE DRAWING | |

| REVISIONS | | | |
|-----------|-------------|------|----------|
| LTR | DESCRIPTION | DATE | APPROVED |

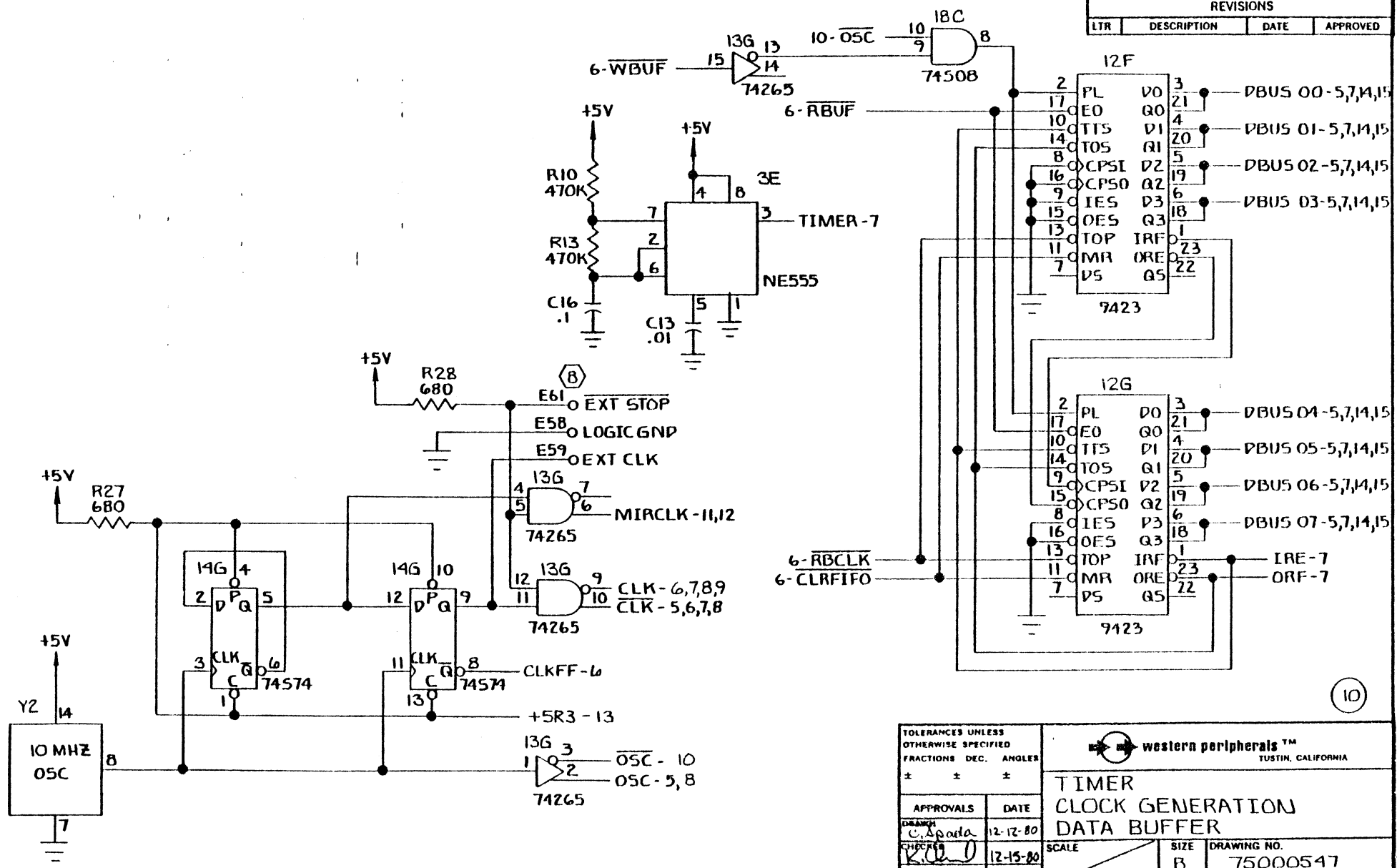

TOLERANCES UNLESS OTHERWISE SPECIFIED
FRACTIONS DEC. ANGLES
± ± ±



**TIMER
CLOCK GENERATION
DATA BUFFER**

| APPROVALS | DATE |
|---------------------|----------|
| DRANK C. Spada | 12-12-80 |
| CHECKED K. O. D. | 12-15-80 |

| | | |
|-------|------|-------------|
| SCALE | SIZE | DRAWING NO. |
| | B | 75000547 |

DO NOT SCALE DRAWING SHEET 11 OF 18

| REVISIONS | | | |
|-----------|-------------|------|----------|
| LTR | DESCRIPTION | DATE | APPROVED |

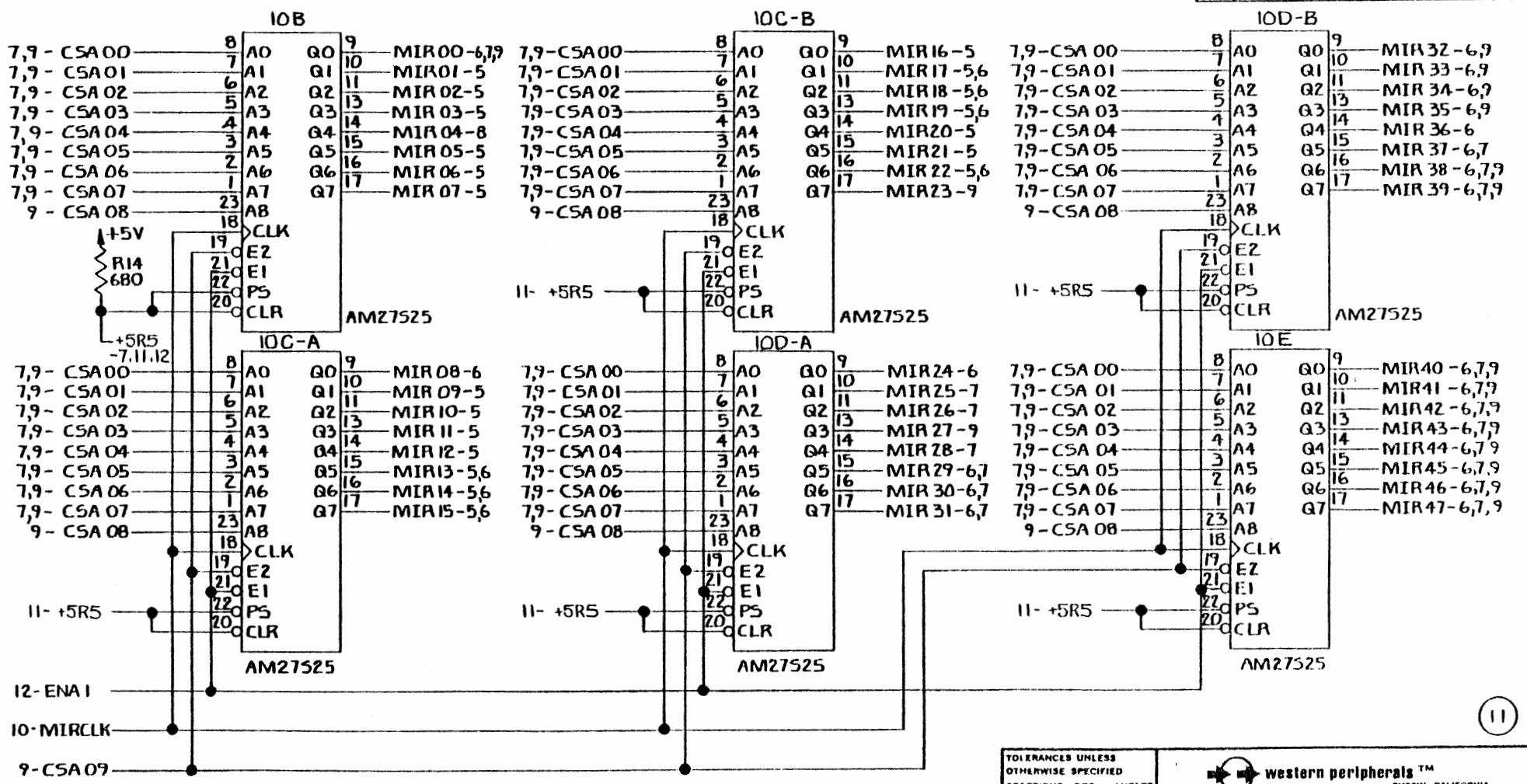

11

| | | | |
|---------------------------------------|----------|--|----------------------------|
| TOLERANCES UNLESS OTHERWISE SPECIFIED | | western peripherals™ TUSTIN, CALIFORNIA | |
| FRACTIONS | DEC. | | |
| ± | ± | ± | CONTROL STORE 0-511 |
| APPROVALS | DATE | SCALE | |
| DRAWN C. Apoda CHECKED | 12-12-80 | 12-15-80 | |
| DO NOT SCALE DRAWING | | SIZE B | DRAWING NO. 75000547 |
| | | | SHEET 12 OF 18 |

| REVISIONS | | | |
|-----------|-------------|------|----------|
| LTR | DESCRIPTION | DATE | APPROVED |

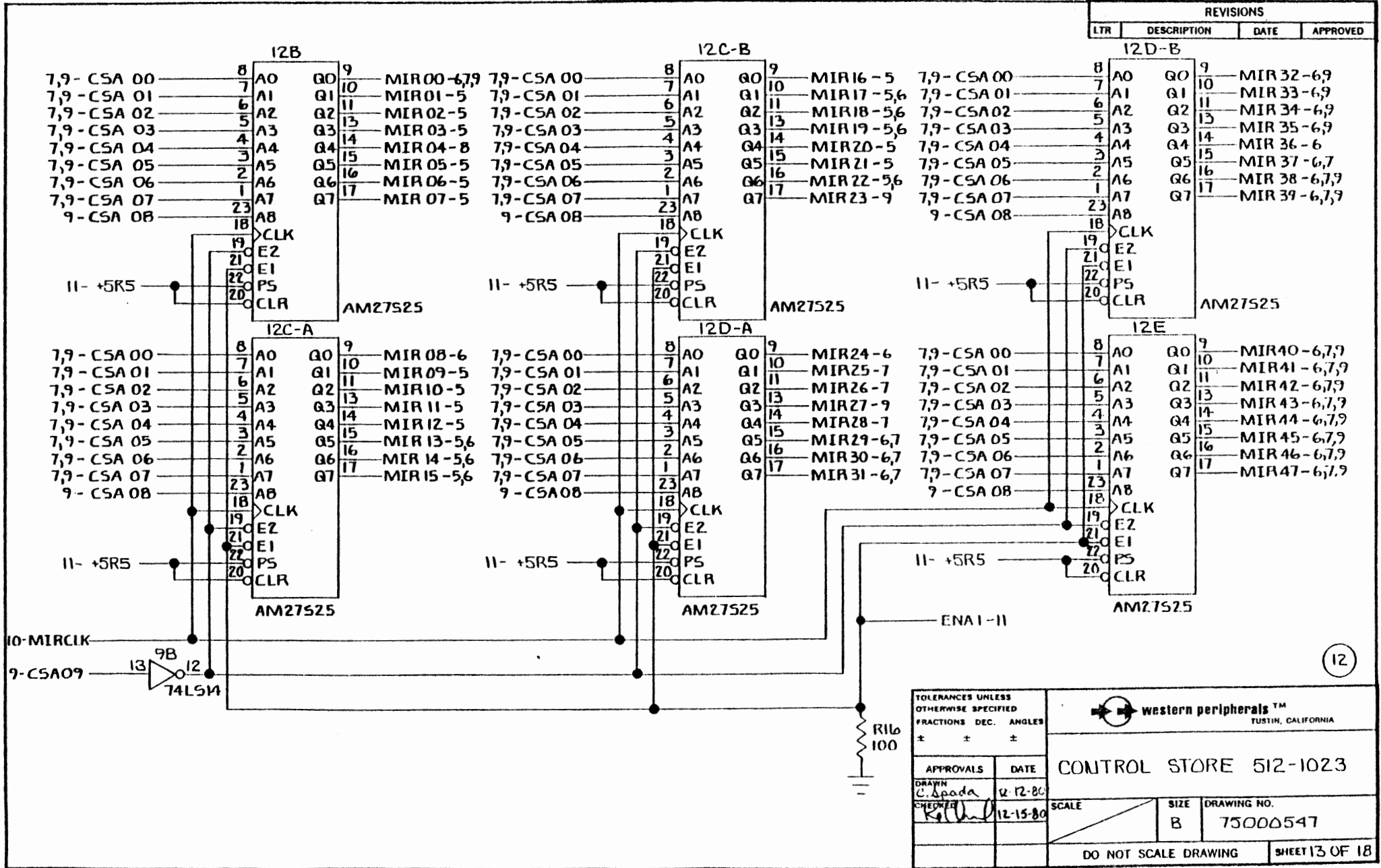

12

| | |
|---------------------------------------|----------|
| TOLERANCES UNLESS OTHERWISE SPECIFIED | |
| FRACTIONS DEC. | ANGLES |
| ± | ± |
| APPROVALS | DATE |
| DRAWN C. Spada | 12-12-80 |
| CHECKED K. [Signature] | 12-15-80 |

western peripherals™
TUSTIN, CALIFORNIA

CONTROL STORE 512-1023

| | | |
|-------|------|-------------|
| SCALE | SIZE | DRAWING NO. |
| | B | 75000547 |

DO NOT SCALE DRAWING SHEET 13 OF 18

504109-A

| REVISIONS | | | |
|-----------|-------------|------|----------|
| LTR | DESCRIPTION | DATE | APPROVED |
| | | | |

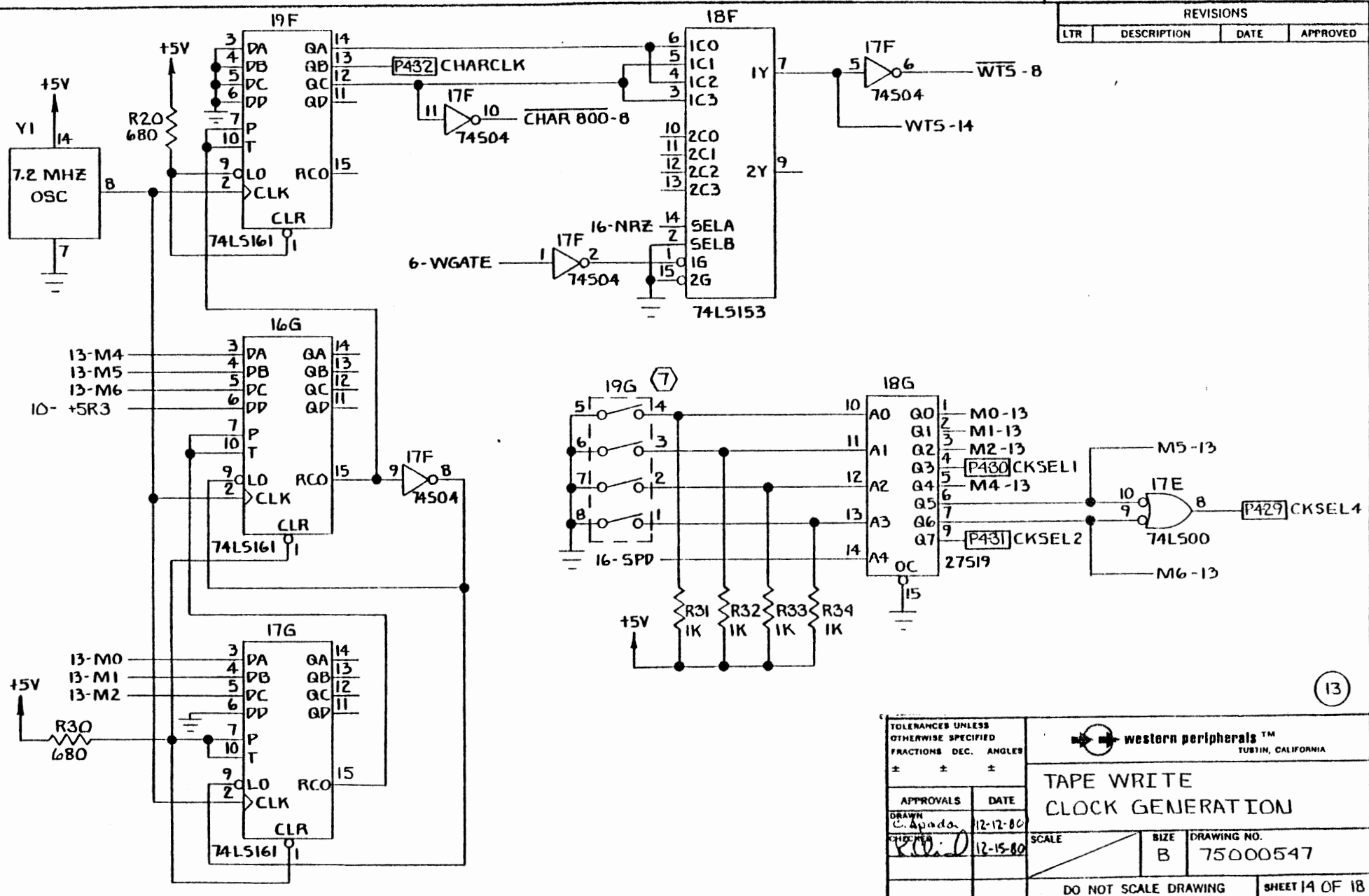

(13)

| | | | |
|---|--|--|--------|
| TOLERANCES UNLESS OTHERWISE SPECIFIED FRACTIONS DEC. ANGLES ± ± ± | | western peripherals™ TUSTIN, CALIFORNIA | |
| APPROVALS DRAWN C. Apada CHECKED [Signature] | | DATE 12-12-80 12-15-80 | |
| TAPE WRITE CLOCK GENERATION | | SCALE | SIZE B |
| DRAWING NO. 75000547 | | SHEET 14 OF 18 | |

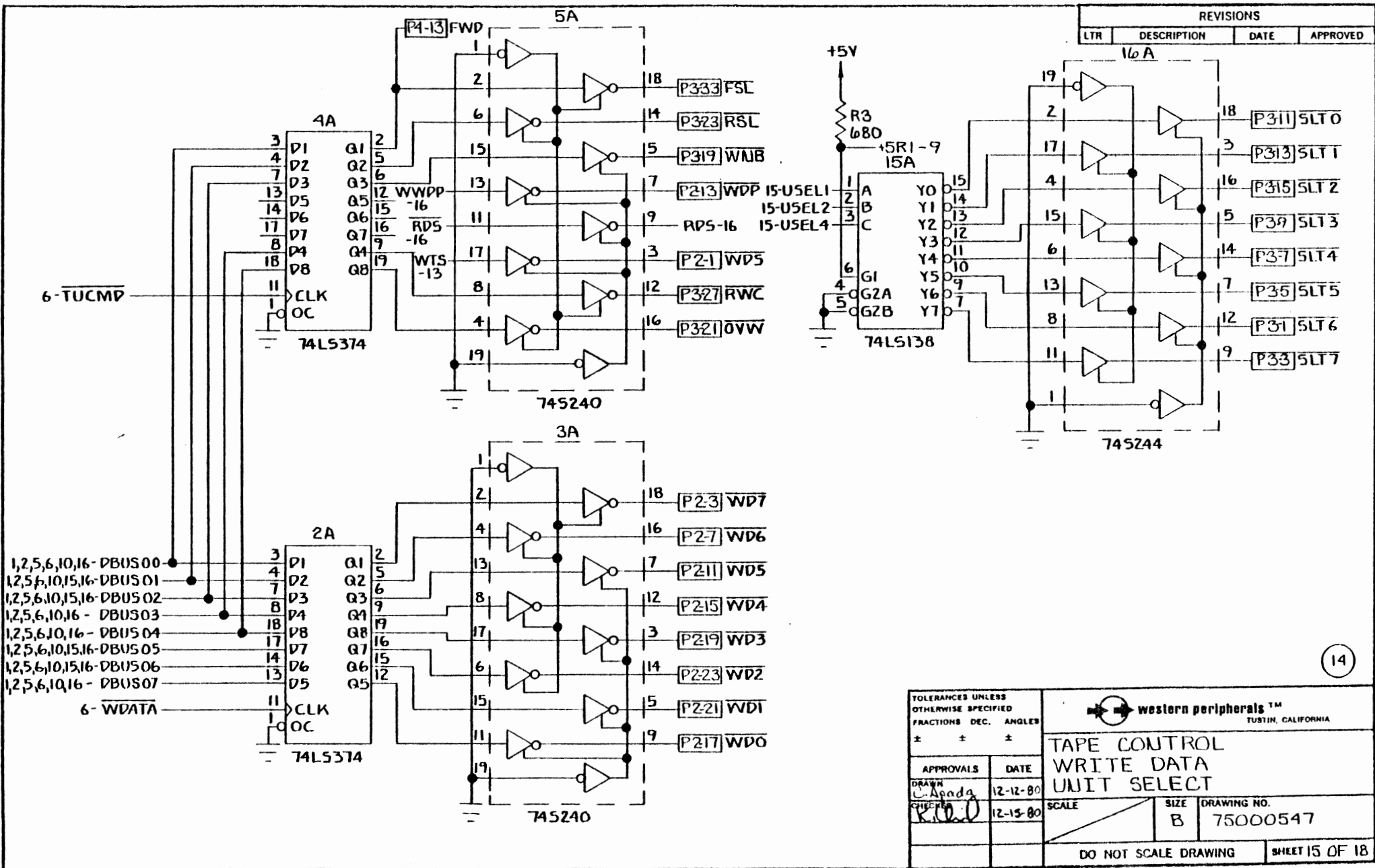

(14)

| | | | |
|---------------------------------------|----------|--|------------------|
| TOLERANCES UNLESS OTHERWISE SPECIFIED | | western peripherals™ TUSTIN, CALIFORNIA | |
| FRACTIONS DEC. ANGLES | ± ± ± | TAPE CONTROL WRITE DATA UNIT SELECT | |
| APPROVALS | DATE | SCALE | SIZE DRAWING NO. |
| DRAWN C. Ando | 12-12-80 | | B 75000547 |
| CHECKED R. D. | 12-13-80 | | |
| DO NOT SCALE DRAWING | | | SHEET 15 OF 18 |

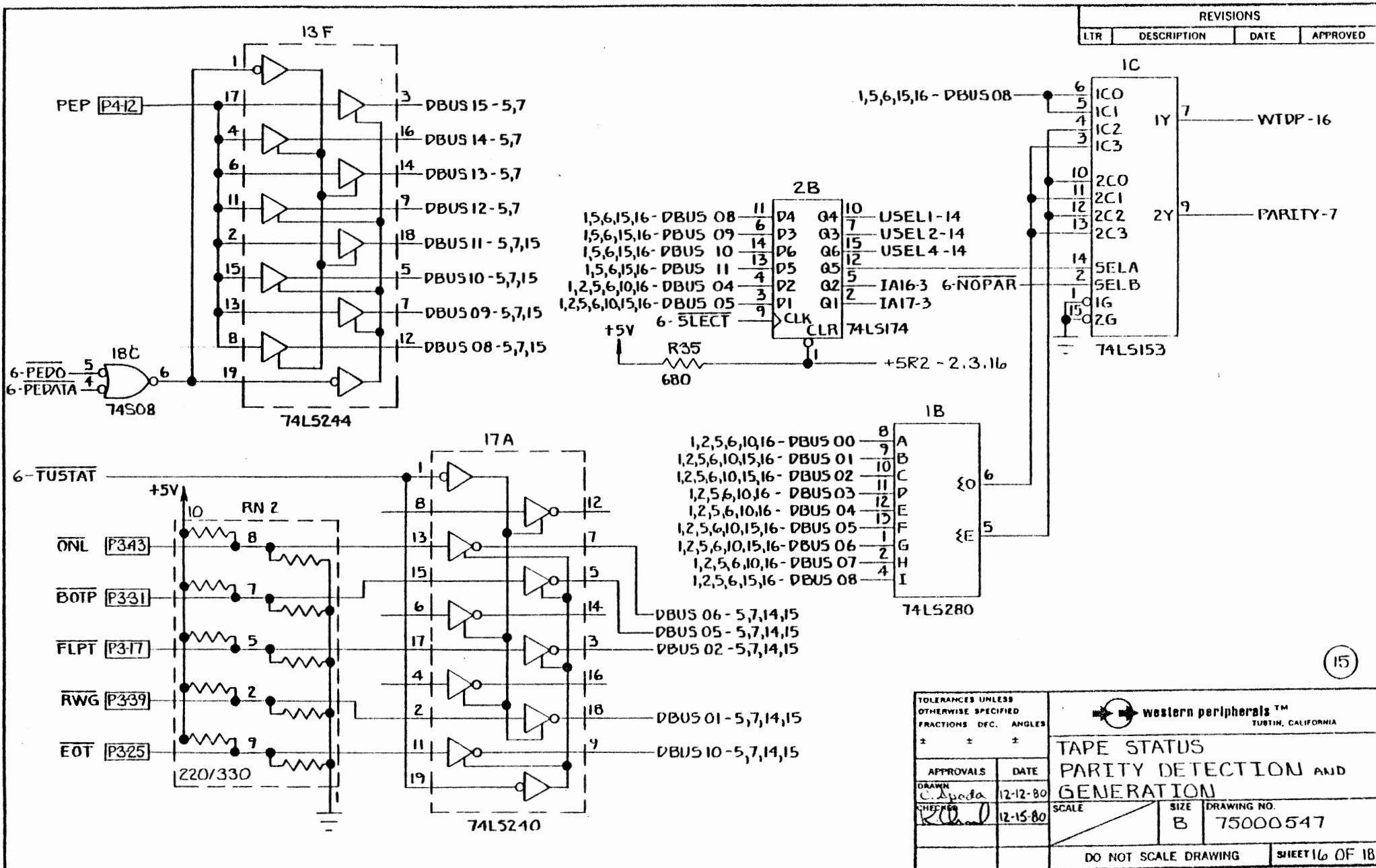

15

| | | | |
|---|--|---|----------------|
| TOLERANCES UNLESS OTHERWISE SPECIFIED FRACTIONS DEC. ANGLES ± ± ± | | western peripherals™ TUSTIN, CALIFORNIA | |
| APPROVALS DRAWN C. Spada CHECKED R. [Signature] | | DATE 12-12-80 12-15-80 | |
| Tape Status Parity Detection and Generation | | SCALE | SIZE B |
| | | DRAWING NO. 75000547 | |
| DO NOT SCALE DRAWING | | | SHEET 16 OF 18 |

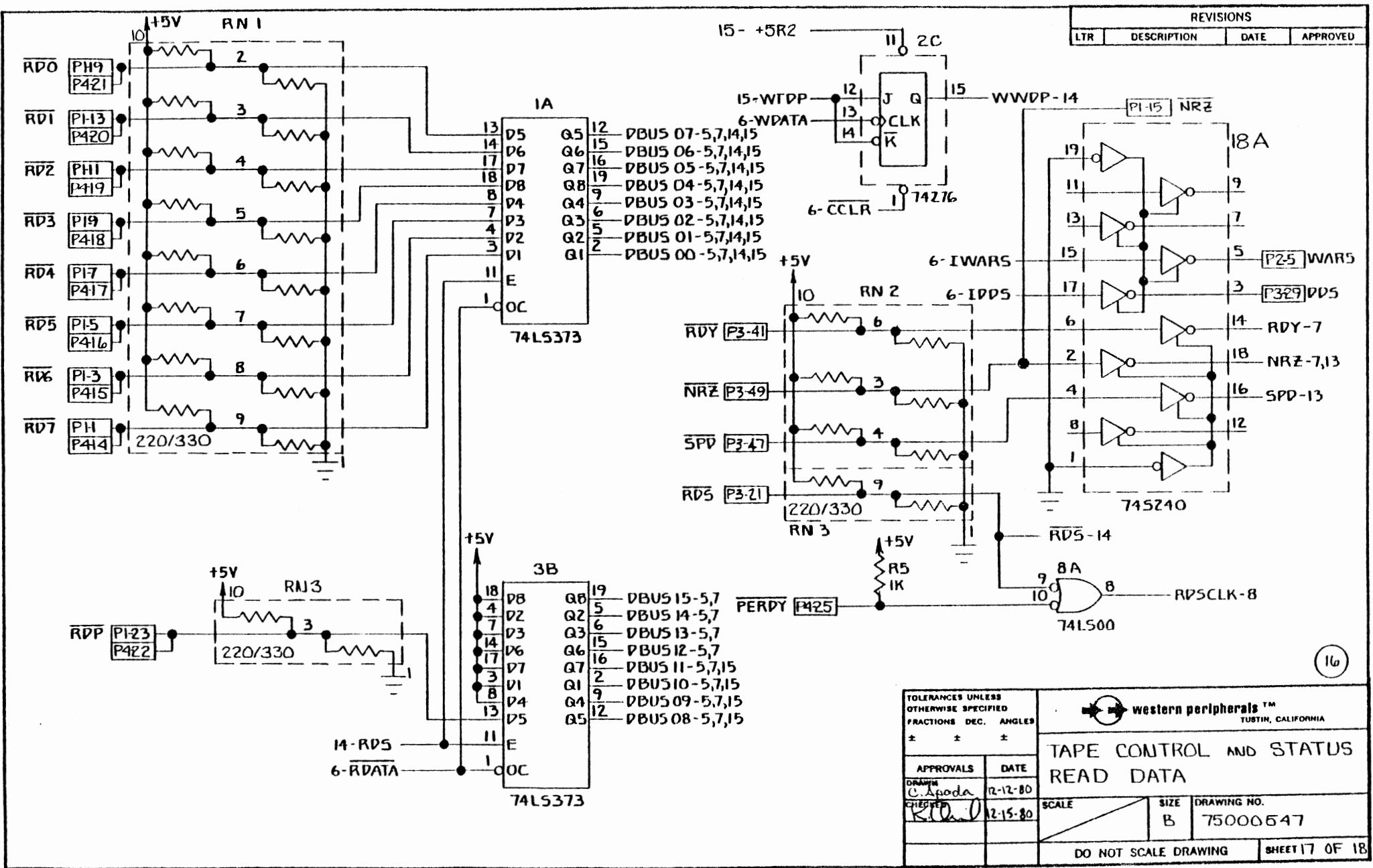

16

| | | | |
|---|--|--|-------------------------|
| TOLERANCES UNLESS OTHERWISE SPECIFIED FRACTIONS DEC. ANGLES ± ± ± | | western peripherals™ TUSTIN, CALIFORNIA | |
| APPROVALS DRAWN C. Spoda CHECKED K. O. | | DATE 12-12-80 12-15-80 | |
| SCALE | | SIZE B | DRAWING NO. 75000547 |
| DO NOT SCALE DRAWING | | | SHEET 17 OF 18 |

| REVISIONS | | | |
|-----------|-------------|------|----------|
| LTR | DESCRIPTION | DATE | APPROVED |

④ DEVICE ADDRESS
STD ADDR 772520₈

| ADDR BIT | ADDR RANGE | E JUMPERS | STD ADDR | INSTALLED JUMPERS |
|----------|------------|-----------|----------|-------------------|
| 17 | | | | |
| 16 | | | | |
| 15 | | | | |
| 14 | | | | |
| 13 | | | | |
| 12 | 0/1 | 13-21 | | |
| 11 | 0/1 | 14-22 | 0 | 14-22 |
| 10 | 0/1 | 15-23 | | |
| 9 | 0/1 | 16-24 | 0 | 16-24 |
| 8 | 0/1 | 17-25 | | |
| 7 | 0/1 | 18-26 | 0 | 18-26 |
| 6 | 0/1 | 19-27 | | |
| 5 | 0/1 | 20-28 | 0 | 20-28 |
| 4 | 0/1 | 62-63 | | |
| 3 | X | | X | |
| 2 | X | | X | |
| 1 | X | | X | |
| 0 | X | | X | |

⑥ INTERRUPT PRIORITY LEVEL

| BR4 | BR5 | BR6 | BR7 |
|-----------|-----------|-----------|-----------|
| E46 → E49 | E46 → E49 | E45 → E48 | E52 → E55 |
| E47 → E50 | E54 → E57 | E53 → E56 | E53 → E56 |

⑤ INTERRUPT VECTOR
STD VECTOR 224₈

| VCTR BIT | E JUMPERS | STD VCTR | INSTALLED JUMPERS |
|----------|-----------|----------|-------------------|
| 7 | 29-35 | 1 | |
| 6 | 30-36 | 0 | 30-36 |
| 5 | 31-37 | 0 | 31-37 |
| 4 | 32-38 | 1 | |
| 3 | 33-39 | 0 | 33-39 |
| 2 | 34-40 | 1 | |
| 1 | | 0 | |
| 0 | | 0 | |

⑦ SPEED SETTING

| SW POS | 125 | 125 | 125 | 125 | 75 | 75 | 75 | 45 | 45 | 37.5 | SELB |
|--------|-----|-----|------|-----|----|------|----|------|----|------|------|
| 196 | 75 | 45 | 37.5 | 25 | 45 | 37.5 | 25 | 37.5 | 25 | 25 | SELA |
| 1 | C | C | C | C | C | C | C | C | C | C | |
| 2 | C | C | C | C | C | C | C | C | C | C | |
| 3 | C | C | C | C | C | C | C | C | C | C | |
| 4 | C | C | C | C | C | C | C | C | C | C | |

TAPE
CTRL
CBL
SWA-4

C = ON
O = OFF

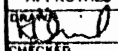
| | | | |
|--|----------|---|----------------|
| TOLERANCES UNLESS OTHERWISE SPECIFIED | |  western peripherals™ TUSTIN, CALIFORNIA | |
| FRACTIONS DEC. | ANGLES | | |
| ± | ± | ± | |
| APPROVALS | DATE | SWITCH AND JUMPER TABLES | |
| CHECKED | | | |
|  HD KOGA | 12-18-80 | SCALE | SIZE |
| | | | B |
| | | DRAWING NO. | |
| | | 75000547 | |
| DO NOT SCALE DRAWING | | | SHEET 18 of 18 |

| REVISIONS | | | |
|-----------|-------------|--------|--------------------|
| LTR | DESCRIPTION | DATE | APPROVED |
| A | RELEASE | 3-2-81 | <i>[Signature]</i> |

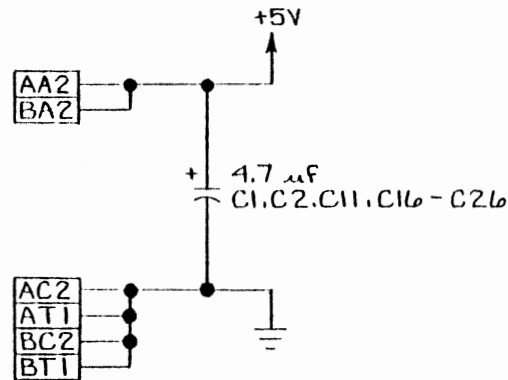

INTERCONNECT

| | P4 | | |
|--------|----|----|---------|
| DBUS01 | 1 | 2 | DBUS00 |
| DBUS03 | 3 | 4 | DBUS02 |
| DBUS06 | 5 | 6 | DBUS07 |
| DBUS05 | 7 | 8 | DBUS04 |
| GND | 9 | 10 | GND |
| | 11 | 12 | PEP |
| FWD | 13 | 14 | RD7 |
| RD6 | 15 | 16 | RD5 |
| RD4 | 17 | 18 | RD3 |
| RD2 | 19 | 20 | RDT |
| RDO | 21 | 22 | RDP |
| PEDATA | 23 | 24 | RDGATE |
| PERDY | 25 | 26 | PEDO |
| SO | 27 | 28 | PESTAT |
| CKSEL4 | 29 | 30 | CKSEL1 |
| CKSEL2 | 31 | 32 | CHARCLK |
| GND | 33 | 34 | PCLK |

| LAST DESIGNATION USED | |
|-----------------------|-----|
| RESISTOR | R24 |
| CAPACITOR | C27 |
| DIODE | CR8 |

3. REFERENCE ASSY. 60000627.
 2. CAPACITOR VALUES ARE IN MICROFARADS.
 1. RESISTANCE VALUES ARE IN OHMS.
- NOTES : UNLESS OTHERWISE SPECIFIED

| | | | |
|---|--|---|--|
| TOLERANCES UNLESS OTHERWISE SPECIFIED FRACTIONS DEC. ANGLES ± ± ± | |  western peripherals™ TUSTIN, CALIFORNIA | |
| APPROVALS DRAWN <i>C. Luoda</i> CHECKED <i>HDK/HA</i> <i>[Signature]</i> | | | |
| DATE 12-24-80 SCALE SIZE B DRAWING NO. 75000554 | | DO NOT SCALE DRAWING SHEET 1 OF 10 | |

| REVISIONS | | | |
|-----------|-------------|------|----------|
| LTR | DESCRIPTION | DATE | APPROVED |

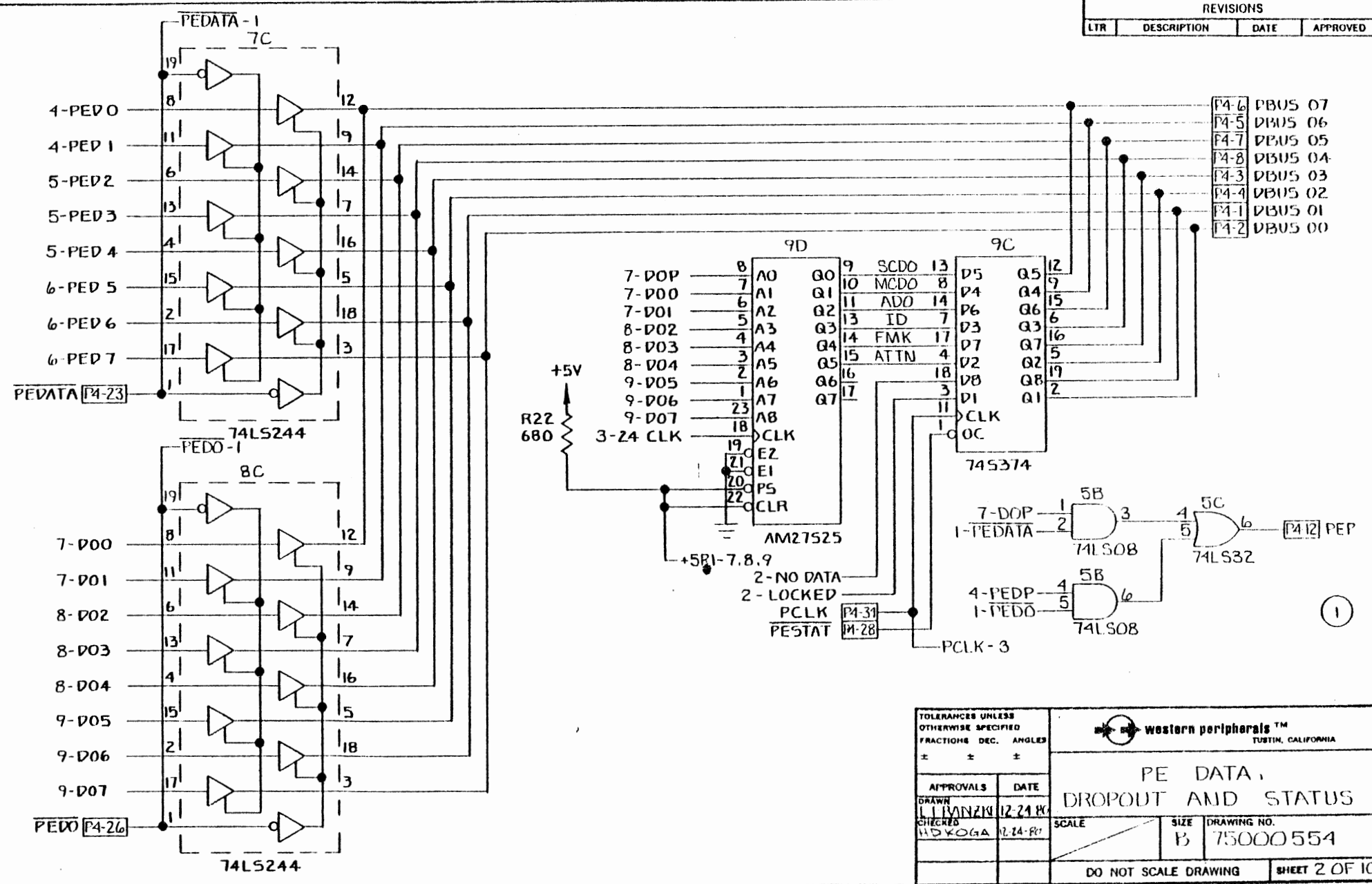

| | |
|------|---------|
| F4-6 | DBUS 07 |
| F4-5 | DBUS 06 |
| F4-7 | DBUS 05 |
| F4-8 | DBUS 04 |
| F4-3 | DBUS 03 |
| F4-4 | DBUS 02 |
| F4-1 | DBUS 01 |
| F4-2 | DBUS 00 |

| | | | |
|--|------|--|---------------|
| TOLERANCES UNLESS OTHERWISE SPECIFIED FRACTIONS DEC. ANGLES ± ± ± | | western peripherals™ TUSTIN, CALIFORNIA | |
| APPROVALS | | DATE | |
| DRAWN L. MANZINI | | 12-24-87 | |
| CHECKED V. D. KOZA | | 12-24-87 | |
| SCALE | SIZE | DRAWING NO. | |
| | B | 75000554 | |
| DO NOT SCALE DRAWING | | | SHEET 2 OF 10 |

| REVISIONS | | | |
|-----------|-------------|------|----------|
| LTR | DESCRIPTION | DATE | APPROVED |
| | | | |

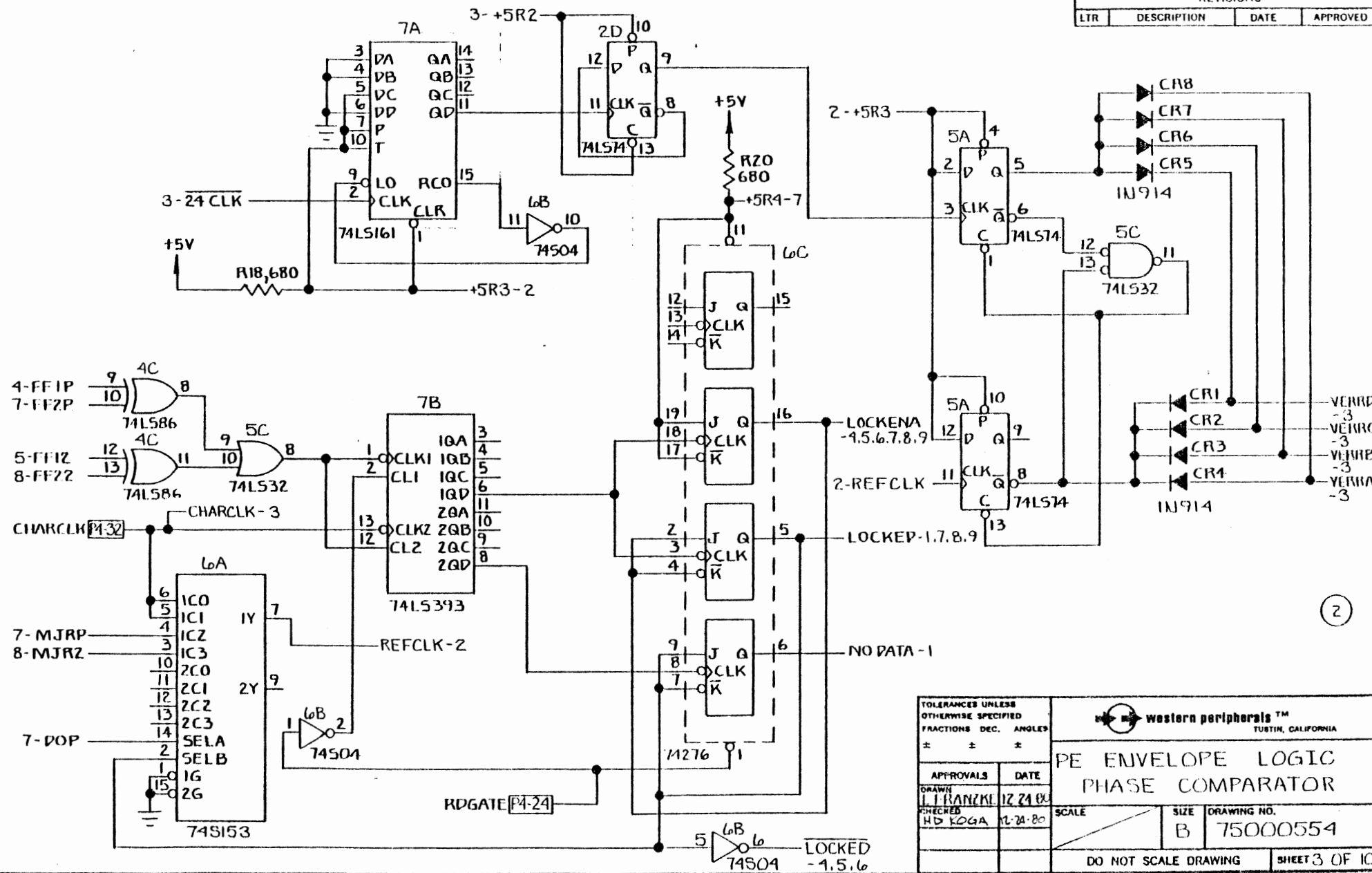

| | | | |
|---------------------------------------|----------|--|------|
| TOLERANCES UNLESS OTHERWISE SPECIFIED | | western peripherals™ TUSTIN, CALIFORNIA | |
| FRACTIONS DEC. ANGLES | ± ± ± | PE ENVELOPE LOGIC PHASE COMPARATOR | |
| APPROVALS | DATE | SCALE | SIZE |
| DRAWN L. I. RANZKE | 12 24 80 | | B |
| CHECKED HD KOGA | 12 24 80 | DRAWING NO. 75000554 | |
| DO NOT SCALE DRAWING | | SHEET 3 OF 10 | |

504110 A

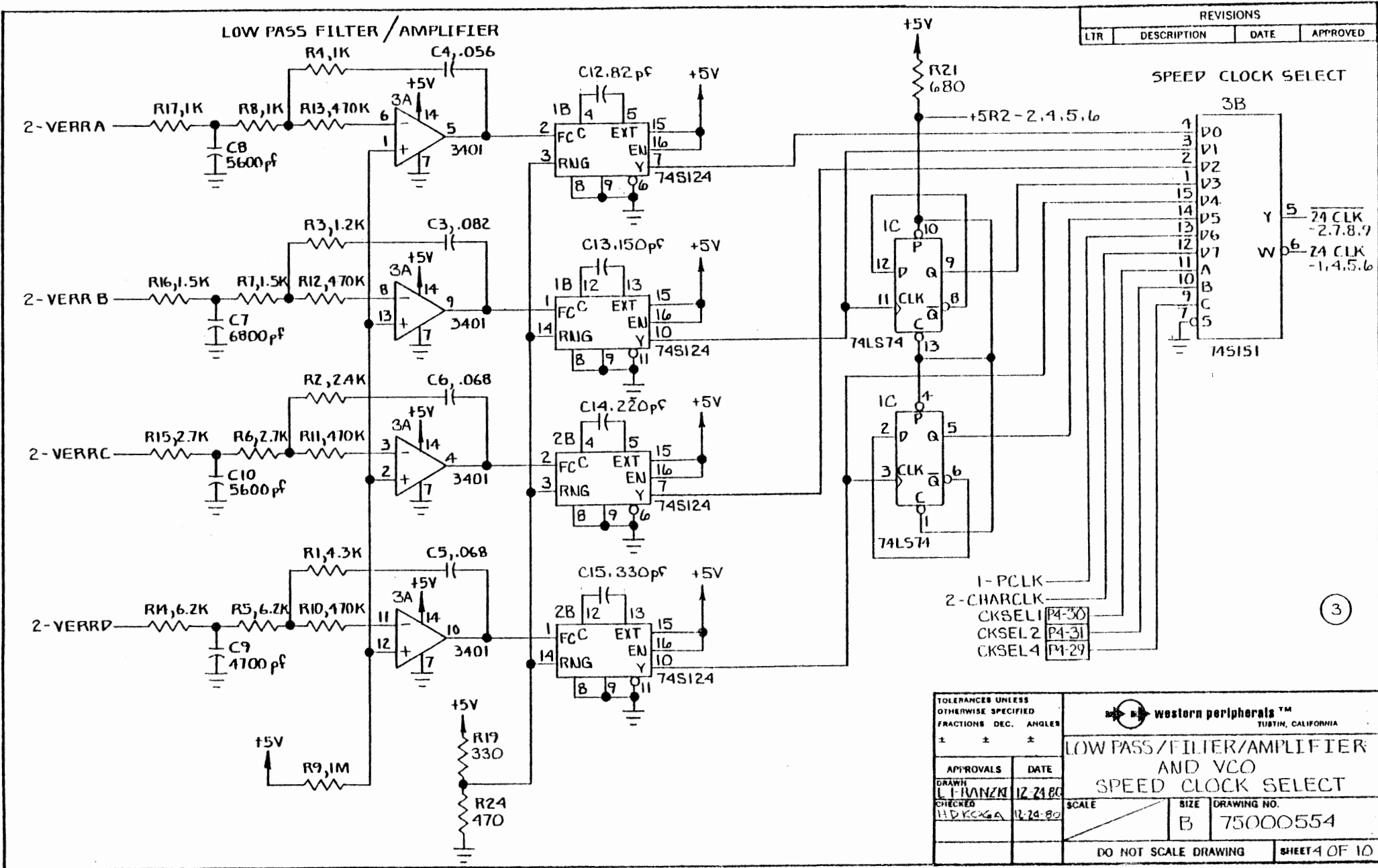

| REVISIONS | | | |
|-----------|-------------|------|----------|
| LTR | DESCRIPTION | DATE | APPROVED |
| | | | |

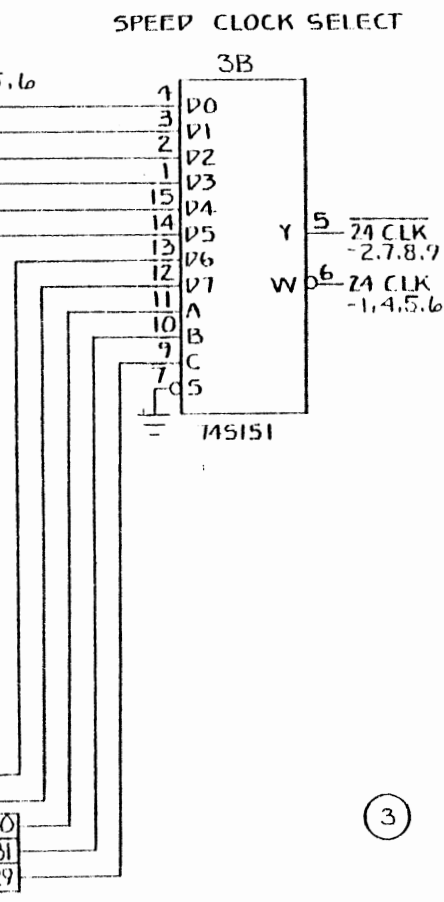

| | | | |
|---------------------------------------|----------|--|---------------|
| TOLERANCES UNLESS OTHERWISE SPECIFIED | | western peripherals™ TUSTIN, CALIFORNIA | |
| FRACTIONS DEC. ANGLES | ± ± ± | LOW PASS/FILTER/AMPLIFIER AND VCO | |
| APPROVALS | DATE | SPEED CLOCK SELECT | |
| DRAWN L. FRANZ | 12-21-80 | SCALE | SIZE B |
| CHECKED H. K. G. A. | 12-24-80 | DRAWING NO. 75000554 | |
| DO NOT SCALE DRAWING | | | SHEET 4 OF 10 |

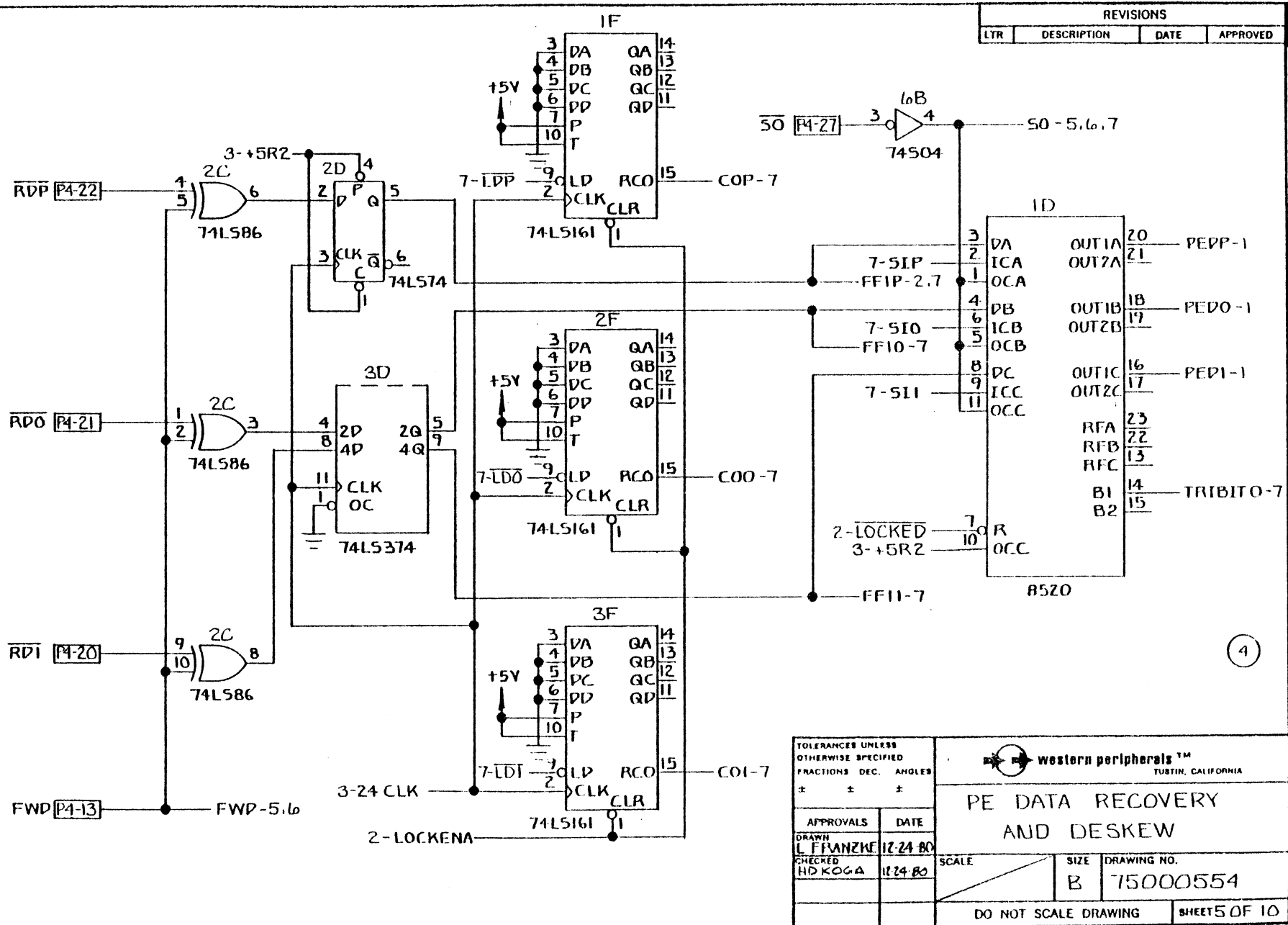

| REVISIONS | | | |
|-----------|-------------|------|----------|
| LTR | DESCRIPTION | DATE | APPROVED |

| | |
|---------------------------------------|-------------|
| TOLERANCES UNLESS OTHERWISE SPECIFIED | |
| FRACTIONS | DEC. ANGLES |
| ± | ± |
| APPROVALS | DATE |
| DRAWN L. FRANZKE | 12-24-80 |
| CHECKED HD KOGA | 12-24-80 |

| | |
|--|----------|
| western peripherals™ TUSTIN, CALIFORNIA | |
| PE DATA RECOVERY AND DESKEW | |
| SCALE | SIZE |
| | B |
| DRAWING NO. | 75000554 |
| DO NOT SCALE DRAWING | |
| SHEET 5 OF 10 | |

| REVISIONS | | | |
|-----------|-------------|------|----------|
| LTR | DESCRIPTION | DATE | APPROVED |

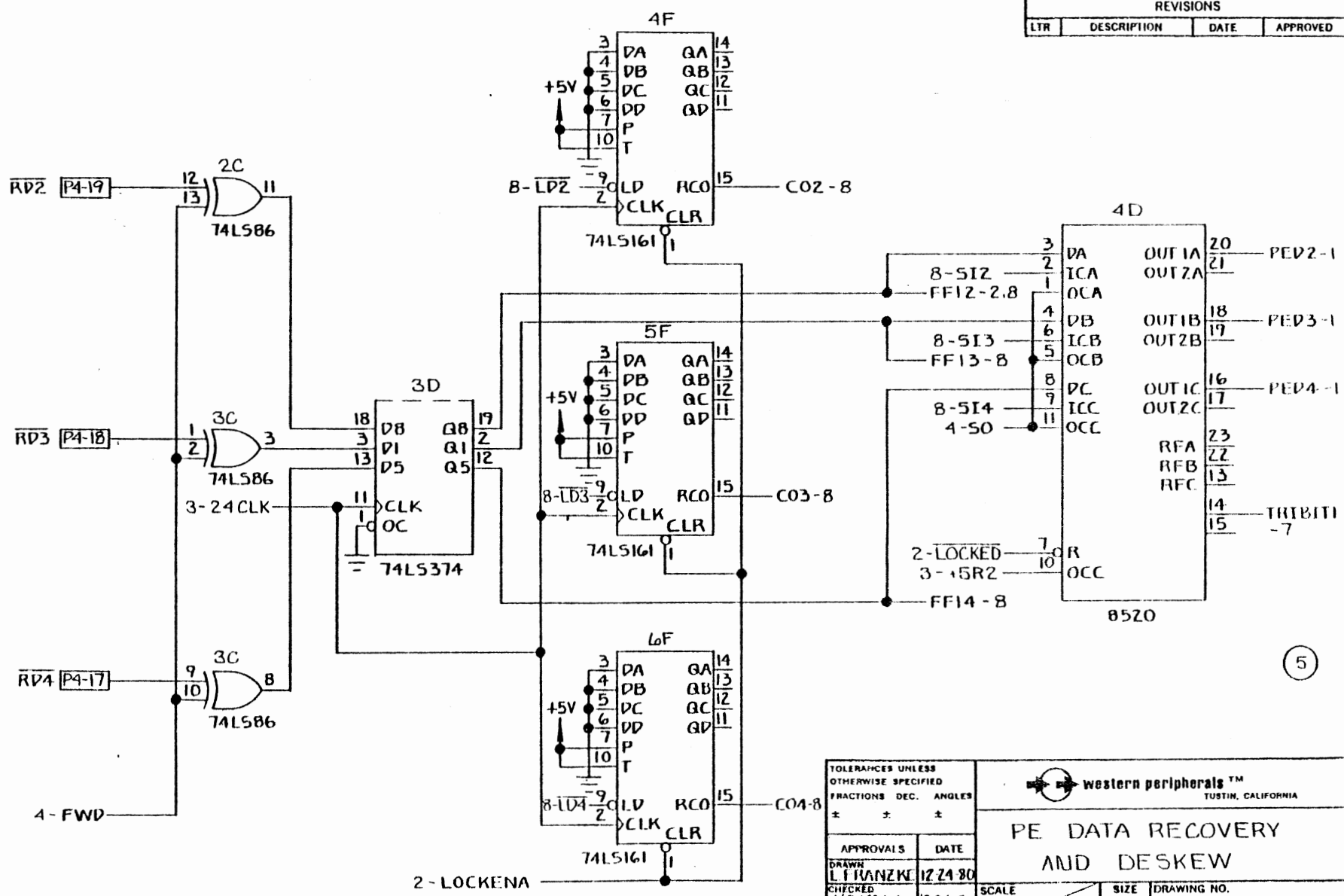

(5)

| | |
|---------------------------------------|----------|
| TOLERANCES UNLESS OTHERWISE SPECIFIED | |
| FRACTIONS DEC. ANGLES | |
| ± ± ± | |
| APPROVALS | DATE |
| DRAWN L. FRANZKE | 12-24-80 |
| CHECKED HDKOGA | 12-24-80 |

western peripherals™
TUSTIN, CALIFORNIA

**PE DATA RECOVERY
AND DESKEW**

| | | |
|----------------------|-----------|-------------------------|
| SCALE | SIZE B | DRAWING NO. 75000554 |
| DO NOT SCALE DRAWING | | SHEET 6 OF 10 |

| REVISIONS | | | |
|-----------|-------------|------|----------|
| LTR | DESCRIPTION | DATE | APPROVED |
| | | | |

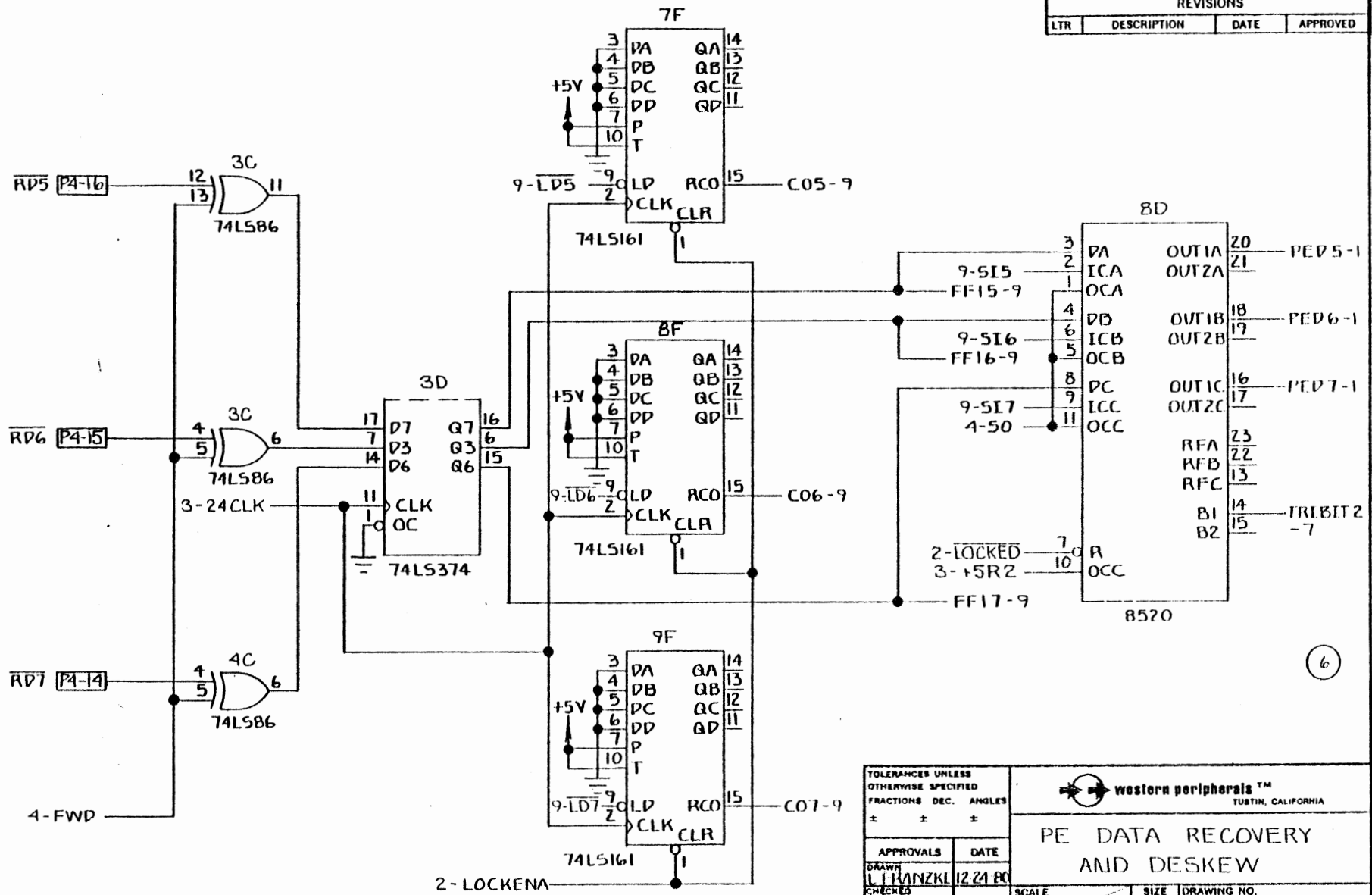

(6)

| | | | |
|---|--|---|---------------|
| TOLERANCES UNLESS OTHERWISE SPECIFIED FRACTIONS DEC. ANGLES ± ± ± | |  western peripherals™ TUSTIN, CALIFORNIA | |
| APPROVALS | | DATE | |
| DRAWN L. HANZL | | 12/21/80 | |
| CHECKED HD KOGA | | 12/24/80 | |
| SCALE | | SIZE | DRAWING NO. |
| | | B | 75000554 |
| DO NOT SCALE DRAWING | | | SHEET 7 OF 10 |

504110 A

| REVISIONS | | | |
|-----------|-------------|------|----------|
| LTR | DESCRIPTION | DATE | APPROVED |
| | | | |

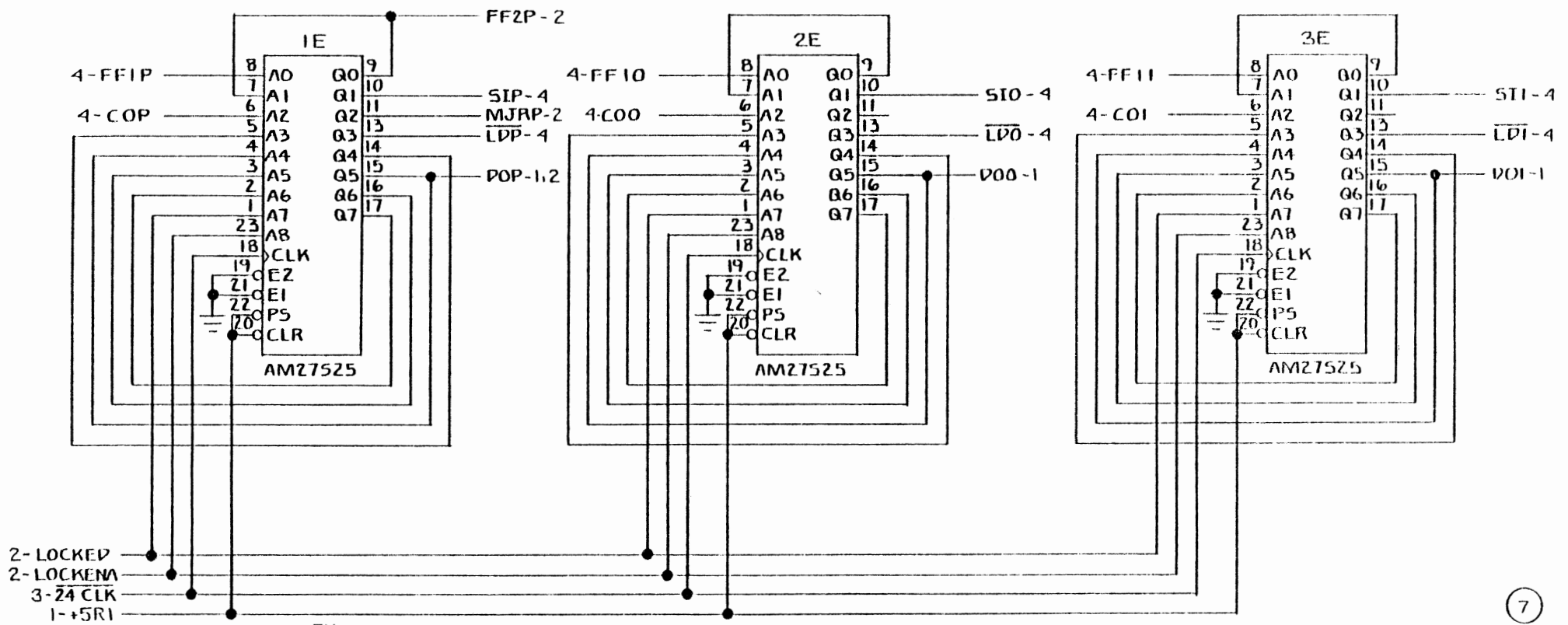

7

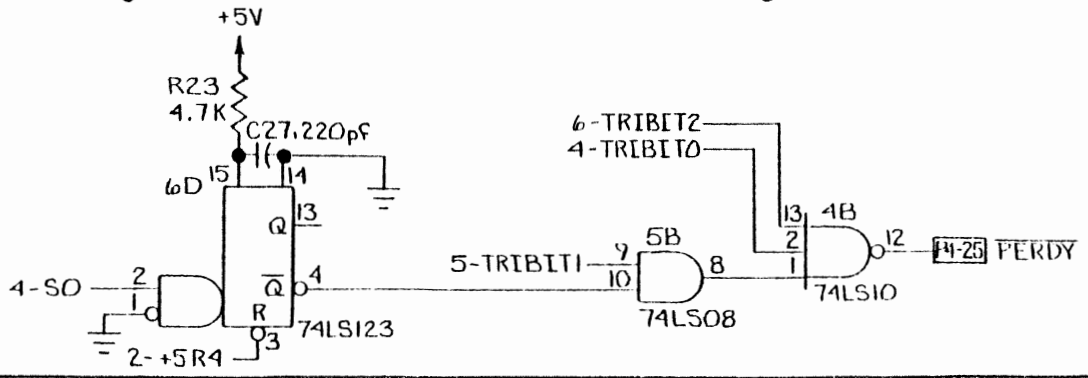

| | | | |
|---|--|--|--|
| TOLERANCES UNLESS OTHERWISE SPECIFIED FRACTIONS DEC. ANGLES * * * | | western peripherals™ TUSTIN, CALIFORNIA | |
| APPROVALS DRAWN L. J. WANKO 12-21-80 CHECKED HDK:OGA 11-24-80 | | PE CHNL SEQ CTRL SCALE: / SIZE: B DRAWING NO.: 75000554 | |
| | | DO NOT SCALE DRAWING | |
| | | SHEET 8 OF 10 | |

504110 A

| REVISIONS | | | |
|-----------|-------------|------|----------|
| LTR | DESCRIPTION | DATE | APPROVED |
| | | | |

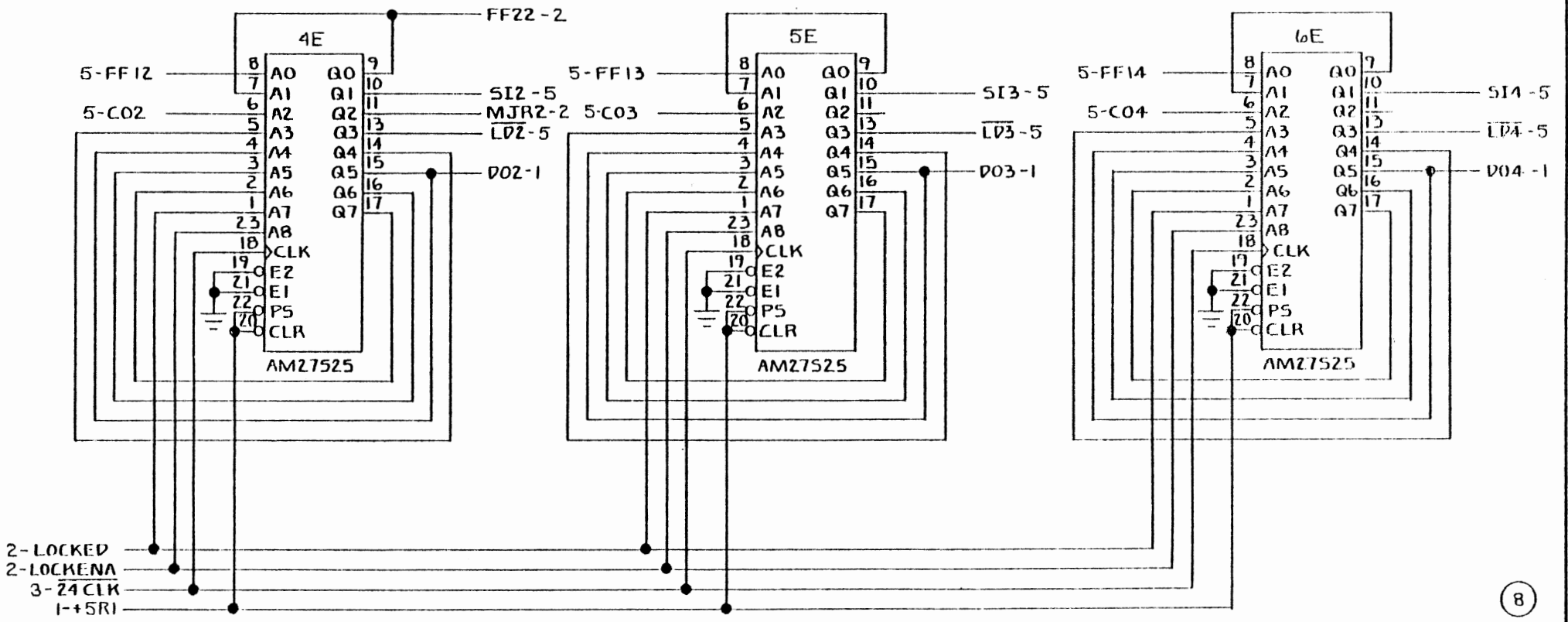

8

| | | | |
|---|--|---|-------------------------|
| TOLERANCES UNLESS OTHERWISE SPECIFIED FRACTIONS DEC. ANGLES ± ± ± | |  western peripherals™ TUSTIN, CALIFORNIA | |
| APPROVALS | | DATE | |
| DRAWN L J SAH/KE | | 12 21 88 | |
| CHECKED HD/KCGA | | 12 24 88 | |
| SCALE | | SIZE B | DRAWING NO. 75000554 |
| DO NOT SCALE DRAWING | | | SHEET 9 OF 10 |

50410 A

| REVISIONS | | | |
|-----------|-------------|------|----------|
| LTR | DESCRIPTION | DATE | APPROVED |
| | | | |

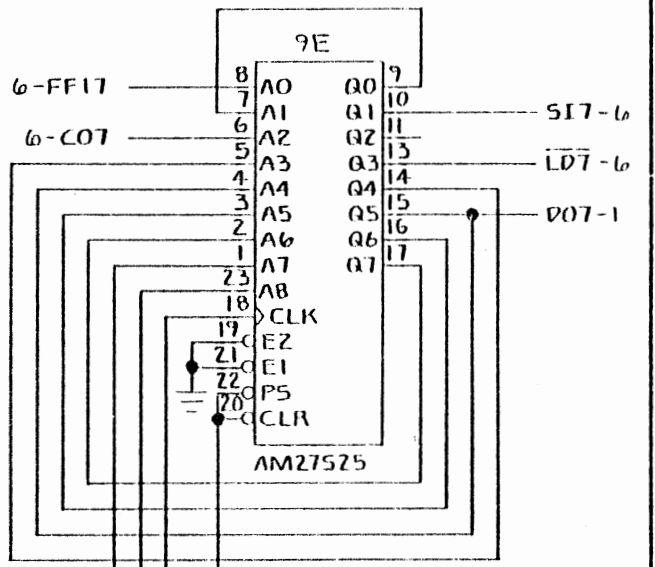
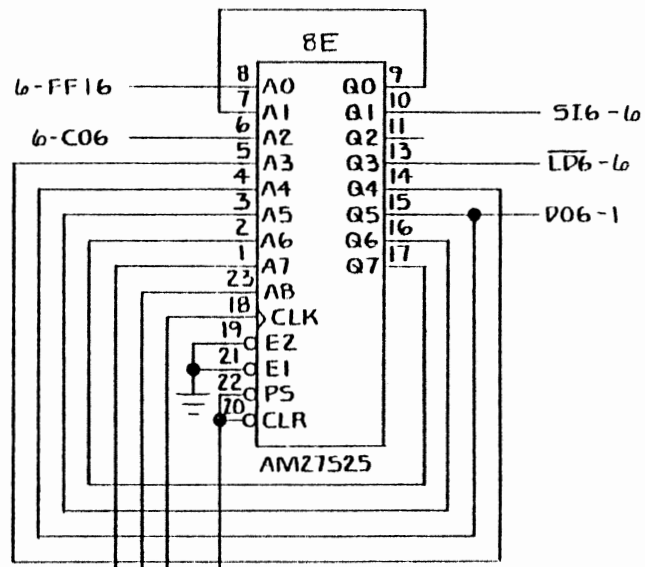
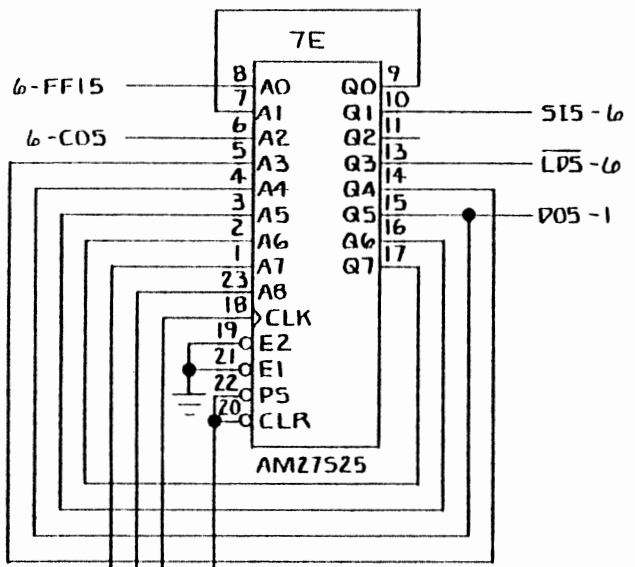

2- LOCKED
 2- LOCKENA
 3- 24 CLK
 1- +5RI

9

| | | | |
|---------------------------------------|----------|---|---|
| TOLERANCES UNLESS OTHERWISE SPECIFIED | | western peripherals™ TUSTIN, CALIFORNIA | |
| FRACTIONS | DEC. | | |
| ± | ± | ± | PE CHNL SEQ CTRL SIZE B DRAWING NO. 75000554 DO NOT SCALE DRAWING SHEET 10 OF 10 |
| APPROVALS | DATE | SCALE | |
| DRAWN L. IVAN/KI | 12-21-80 | | |
| CHECKED HD KOGA | 12-24-80 | | |

504110 A

CONTROL A

| | P3 | | |
|------|----|----|-----|
| SLT6 | 1 | 2 | GND |
| SLT7 | 3 | 4 | GND |
| SLT5 | 5 | 6 | GND |
| SLT4 | 7 | 8 | GND |
| SLT3 | 9 | 10 | GND |
| SLT0 | 11 | 12 | GND |
| SLT1 | 13 | 14 | GND |
| SLT2 | 15 | 16 | GND |
| FLPT | 17 | 18 | GND |
| WNB | 19 | 20 | GND |
| OVW | 21 | 22 | GND |
| RSL | 23 | 24 | GND |
| EOT | 25 | 26 | GND |
| RWC | 27 | 28 | GND |
| DDS | 29 | 30 | GND |
| BOTP | 31 | 32 | GND |
| FSL | 33 | 34 | GND |
| +5V | 35 | 36 | GND |
| +5V | 37 | 38 | GND |
| RWB | 39 | 40 | GND |
| RDY | 41 | 42 | GND |
| OKL | 43 | 44 | GND |
| | 45 | 46 | GND |
| SPD | 47 | 48 | GND |
| NRZ | 49 | 50 | GND |

WRITE BI

| | P2 | | |
|------|----|----|-----|
| WD5 | 1 | 2 | GND |
| WD7 | 3 | 4 | GND |
| WARS | 5 | 6 | GND |
| WD6 | 7 | 8 | GND |
| | 9 | 10 | GND |
| WD5 | 11 | 12 | GND |
| WDP | 13 | 14 | GND |
| WD4 | 15 | 16 | GND |
| WDO | 17 | 18 | GND |
| WD3 | 19 | 20 | GND |
| WDT | 21 | 22 | GND |
| WD2 | 23 | 24 | GND |
| +5V | 25 | 26 | GND |

INTERCONNECT

| | P4 | | |
|--------|----|----|---------|
| DBUS01 | 1 | 2 | DBUS00 |
| DBUS03 | 3 | 4 | DBUS02 |
| DBUS06 | 5 | 6 | DBUS07 |
| DBUS05 | 7 | 8 | DBUS04 |
| GND | 9 | 10 | GND |
| | 11 | 12 | PEP |
| FWD | 13 | 14 | RD7 |
| RD6 | 15 | 16 | RD5 |
| RD4 | 17 | 18 | RD3 |
| RD2 | 19 | 20 | RDI |
| RDO | 21 | 22 | RDP |
| PEDATA | 23 | 24 | RGATE |
| PERDY | 25 | 26 | PEDO |
| SO | 27 | 28 | PESTAT |
| CKSEL4 | 29 | 30 | CKSEL1 |
| CKSEL2 | 31 | 32 | CHARCLK |
| GND | 33 | 34 | LIPCLK |

READ B2

| | P1 | | |
|-----|----|----|-----|
| RD7 | 1 | 2 | GND |
| RD6 | 3 | 4 | GND |
| RD5 | 5 | 6 | GND |
| RD4 | 7 | 8 | GND |
| RD3 | 9 | 10 | GND |
| RD2 | 11 | 12 | GND |
| RDT | 13 | 14 | GND |
| NRZ | 15 | 16 | GND |
| | 17 | 18 | GND |
| RDO | 19 | 20 | GND |
| RDS | 21 | 22 | GND |
| RDP | 23 | 24 | GND |
| | 25 | 26 | GND |

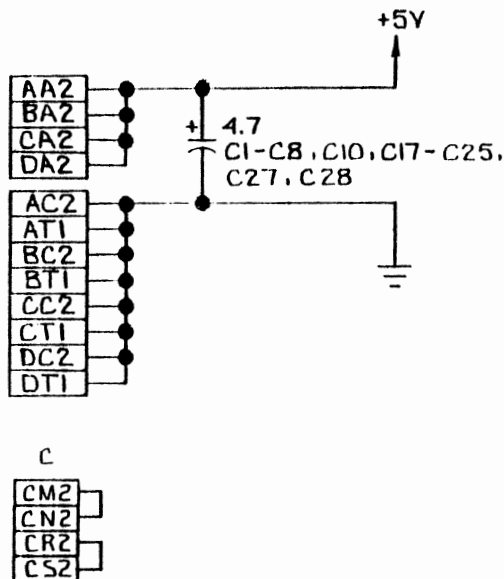

| LAST DESIGNATION USED | |
|-----------------------|------|
| RESISTOR | R40 |
| CAPACITOR | C30 |
| OSCILLATOR | Y2 |
| LIGHT EMITTING DIODE | LED5 |
| RESISTOR NETWORK | RN5 |

REFERENCE DESIGNATIONS NOT USED:
 R15
 C9
 C21a
 E41-E44
 E51

| REVISIONS | | | |
|-----------|-----------------------|---------|--------------------|
| LTR | DESCRIPTION | DATE | APPROVED |
| A | RELEASE TO PRODUCTION | 2-27-81 | <i>[Signature]</i> |
| B | REVISED PER ECD # 998 | 3-31-82 | <i>[Signature]</i> |

- 8. FOR TEST ONLY.
 - 7. SEE SPEED SETTING TABLE.
 - 6. SEE INTERRUPT PRIORITY LEVEL TABLE.
 - 5. SEE INTERRUPT VECTOR TABLE.
 - 4. SEE DEVICE ADDRESS TABLE.
 - 3. REFERENCE ASSY. 60000866
 - 2. CAPACITOR VALUES ARE IN MICROFARADS.
 - 1. RESISTANCE VALUES ARE IN OHMS.
- NOTES: UNLESS OTHERWISE SPECIFIED

| | | | |
|---|-----------------------------------|--|---|
| TOLERANCES UNLESS OTHERWISE SPECIFIED | | western peripherals™ TUSTIN, CALIFORNIA | |
| FRACTIONS | DEC. | | |
| ± | ± | ± | SCHEMATIC TC 151 TAPE CONTROLLER |
| APPROVALS | DATE | SCALE | |
| DRAWN <i>C. Hoada</i> CHECKED <i>[Signature]</i> | 12-12-80 12-15-80 14 Dec 80 | SIZE B | |
| DO NOT SCALE DRAWING | | DRAWING NO. 75000778 | |
| | | | SHEET 1 OF 18 |

| REVISIONS | | | |
|-----------|-------------|------|----------|
| LTR | DESCRIPTION | DATE | APPROVED |

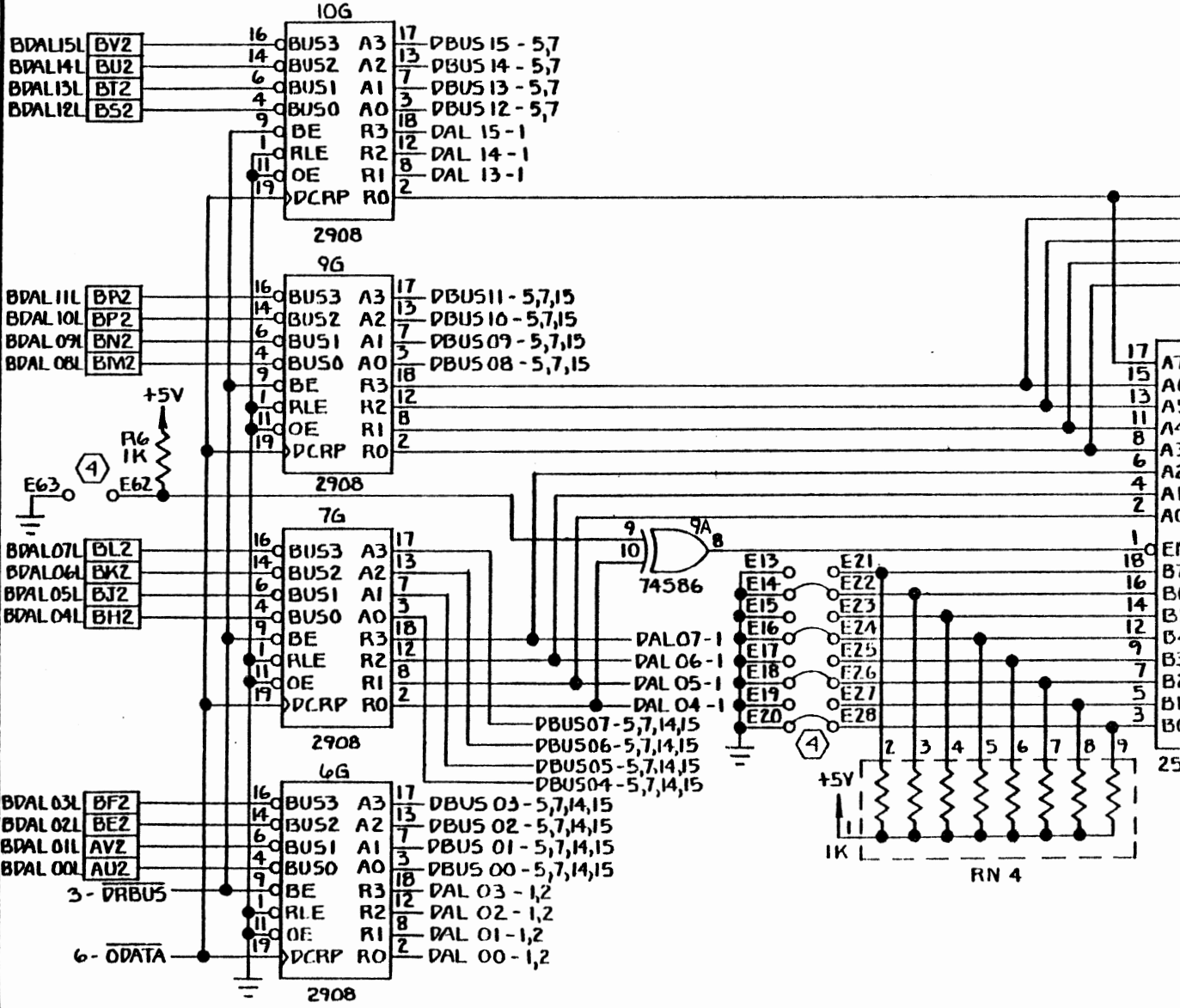

| 8G | | | | |
|----------|----|-----|-------|-------------------|
| 1- DAL07 | 4 | 2D | 2Q 5 | DBUS 07-5,7,14,15 |
| 1- DAL06 | 8 | 4D | 4Q 9 | DBUS 06-5,7,14,15 |
| 1- DAL05 | 7 | 3D | 3Q 6 | DBUS 05-5,7,14,15 |
| | 17 | 7D | 7Q 16 | DBUS 12-5,7 |
| | 18 | 8D | 8Q 19 | DBUS 11-5,7,15 |
| | 14 | 6D | 6Q 15 | DBUS 10-5,7,15 |
| | 13 | 5D | 5Q 12 | DBUS 09-5,7,15 |
| | 3 | 1D | 1Q 2 | DBUS 08-5,7,15 |
| | 11 | ENG | | |
| | 10 | OC | | |

| 5G | | | | |
|------------|----|-----|-------|-------------------|
| 1- DAL 15 | 3 | 1D | 1Q 2 | DBUS 15-5,7 |
| 1- DAL 14 | 8 | 4D | 4Q 9 | DBUS 14-5,7 |
| 1- DAL 13 | 7 | 3D | 3Q 6 | DBUS 13-5,7 |
| 1- DAL 04 | 4 | 2D | 2Q 5 | DBUS 04-5,7,14,15 |
| 1- DAL 03 | 17 | 7D | 7Q 16 | DBUS 03-5,7,14,15 |
| 1- DAL 02 | 13 | 5D | 5Q 12 | DBUS 02-5,7,14,15 |
| 1- DAL 01 | 14 | 6D | 6Q 15 | DBUS 01-5,7,14,15 |
| 1- DAL 00 | 18 | 8D | 8Q 19 | DBUS 00-5,7,14,15 |
| 3- DALSTRB | 11 | ENG | | |
| 6- IDATA | 10 | OC | | |

| | | | |
|---|--|--|---------------|
| TOLERANCES UNLESS OTHERWISE SPECIFIED FRACTIONS DEC. ANGLES ± ± ± | | western peripherals™ TUSTIN, CALIFORNIA | |
| APPROVALS | | DATE | |
| DRAWN <i>C. Ayuda</i> | | 12-12-80 | |
| CHECKED <i>[Signature]</i> | | 12-15-80 | |
| SCALE | | SIZE | DRAWING NO. |
| | | B | 75000778 |
| DO NOT SCALE DRAWING | | | SHEET 2 OF 18 |

| REVISIONS | | | |
|-----------|-------------|------|----------|
| LTR | DESCRIPTION | DATE | APPROVED |
| | | | |

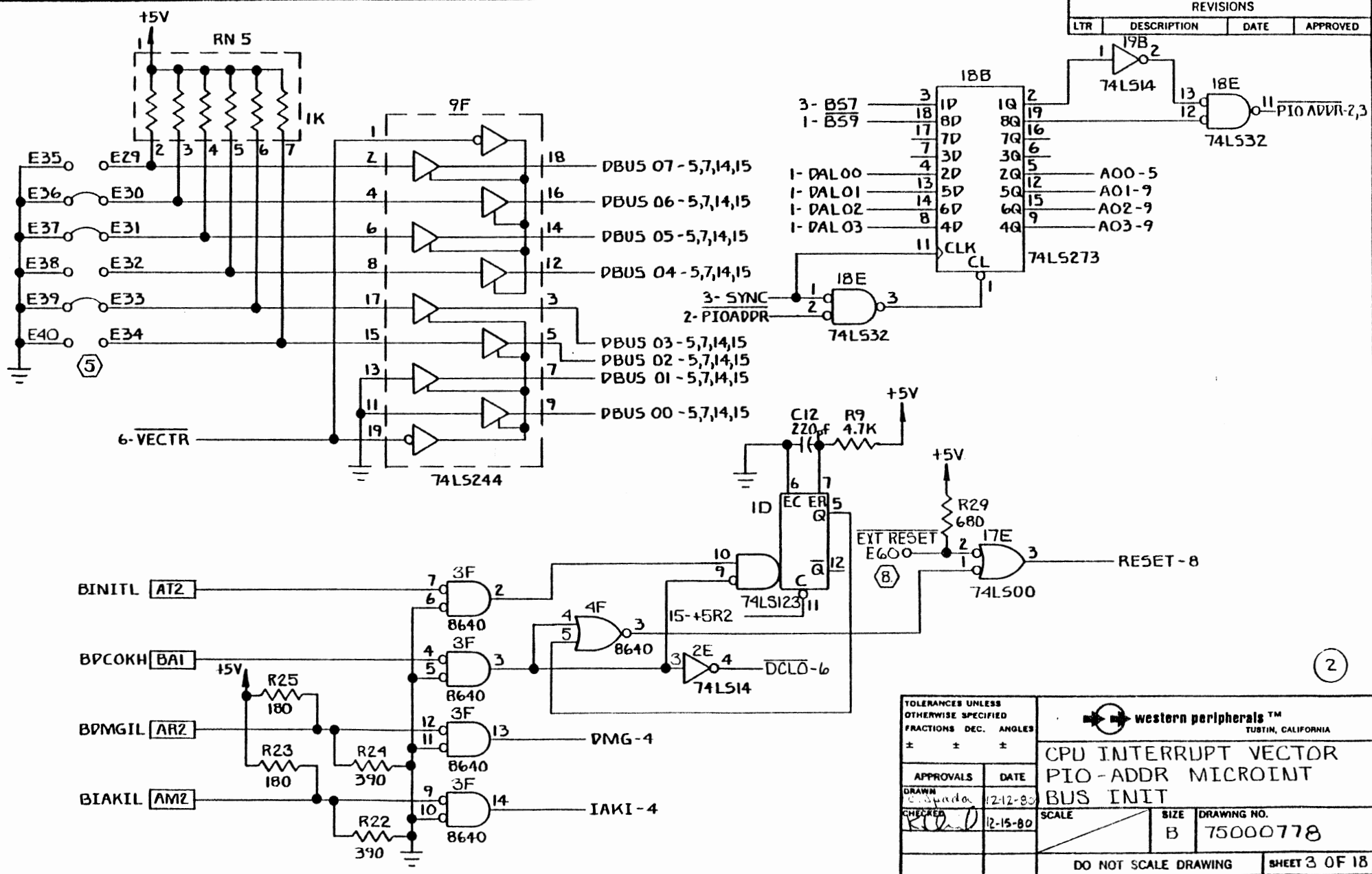

| | | | | |
|---------------------------------------|----------|-------------|---|----------|
| TOLERANCES UNLESS OTHERWISE SPECIFIED | | | western peripherals™ TUSTIN, CALIFORNIA | |
| FRACTIONS | DEC. | ANGLES | | |
| ± | ± | ± | CPU INTERRUPT VECTOR PIO-ADDR MICRINT BUS INIT | |
| APPROVALS | DATE | SCALE | | |
| DRAWN <i>C. Spada</i> | 12-12-80 | SIZE | | |
| CHECKED <i>R. L...</i> | 12-15-80 | DRAWING NO. | | |
| DO NOT SCALE DRAWING | | | B | 75000778 |
| SHEET 3 OF 18 | | | | |

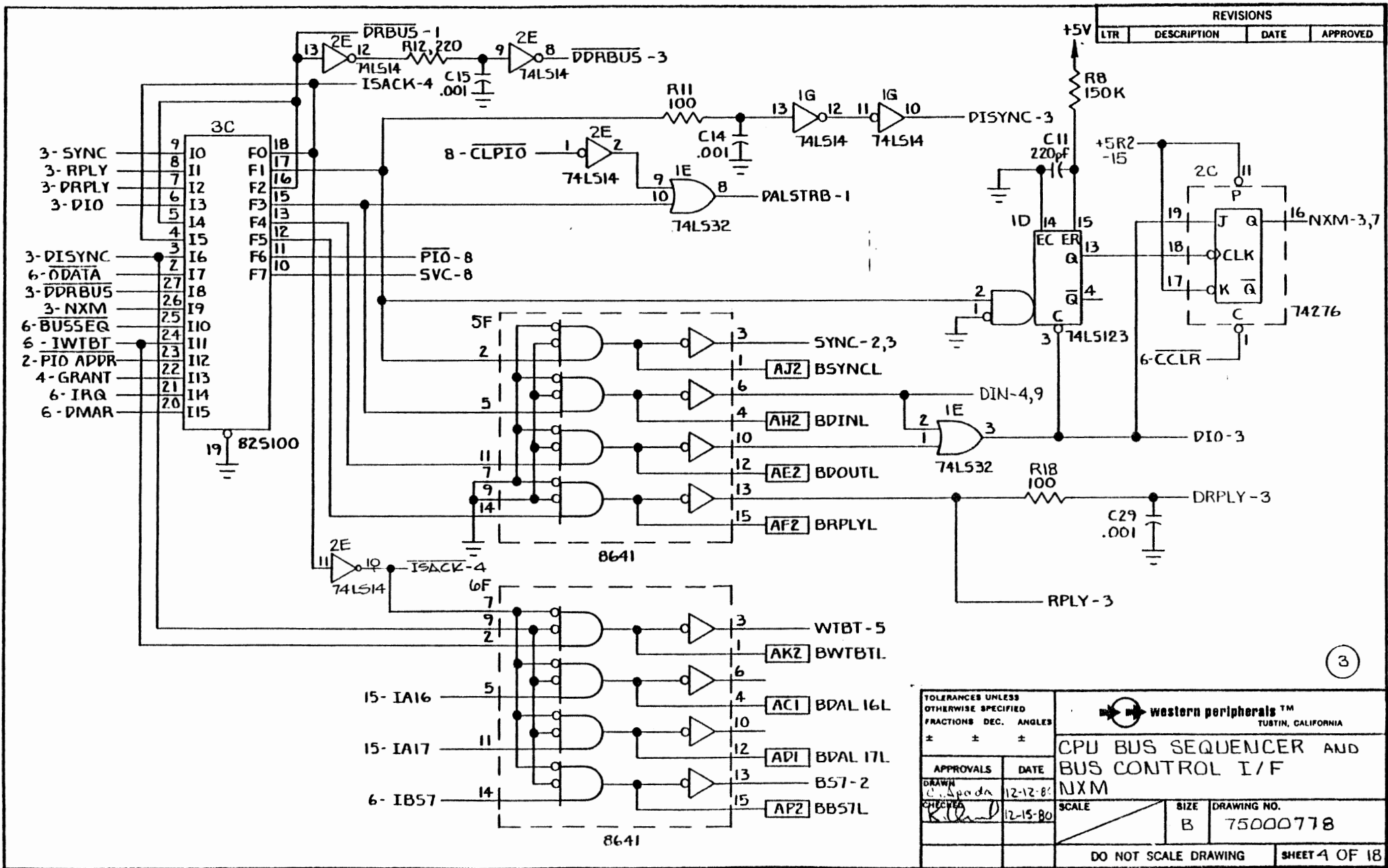

| REVISIONS | | | |
|-----------|-------------|------|----------|
| LTR | DESCRIPTION | DATE | APPROVED |
| | | | |

(3)

| | | | |
|--|---|--|---------------|
| TOLERANCES UNLESS OTHERWISE SPECIFIED FRACTIONS DEC. ANGLES | | western peripherals™ TUSTIN, CALIFORNIA | |
| ± | ± | ± | ± |
| APPROVALS | | DATE | |
| DRAWN C. Spada | | 12-12-80 | |
| CHECKED K. [Signature] | | 12-15-80 | |
| SCALE | | SIZE | DRAWING NO. |
| | | B | 75000778 |
| DO NOT SCALE DRAWING | | | SHEET 4 OF 18 |

| REVISIONS | | | |
|-----------|-------------|------|----------|
| LTR | DESCRIPTION | DATE | APPROVED |
| | | | |

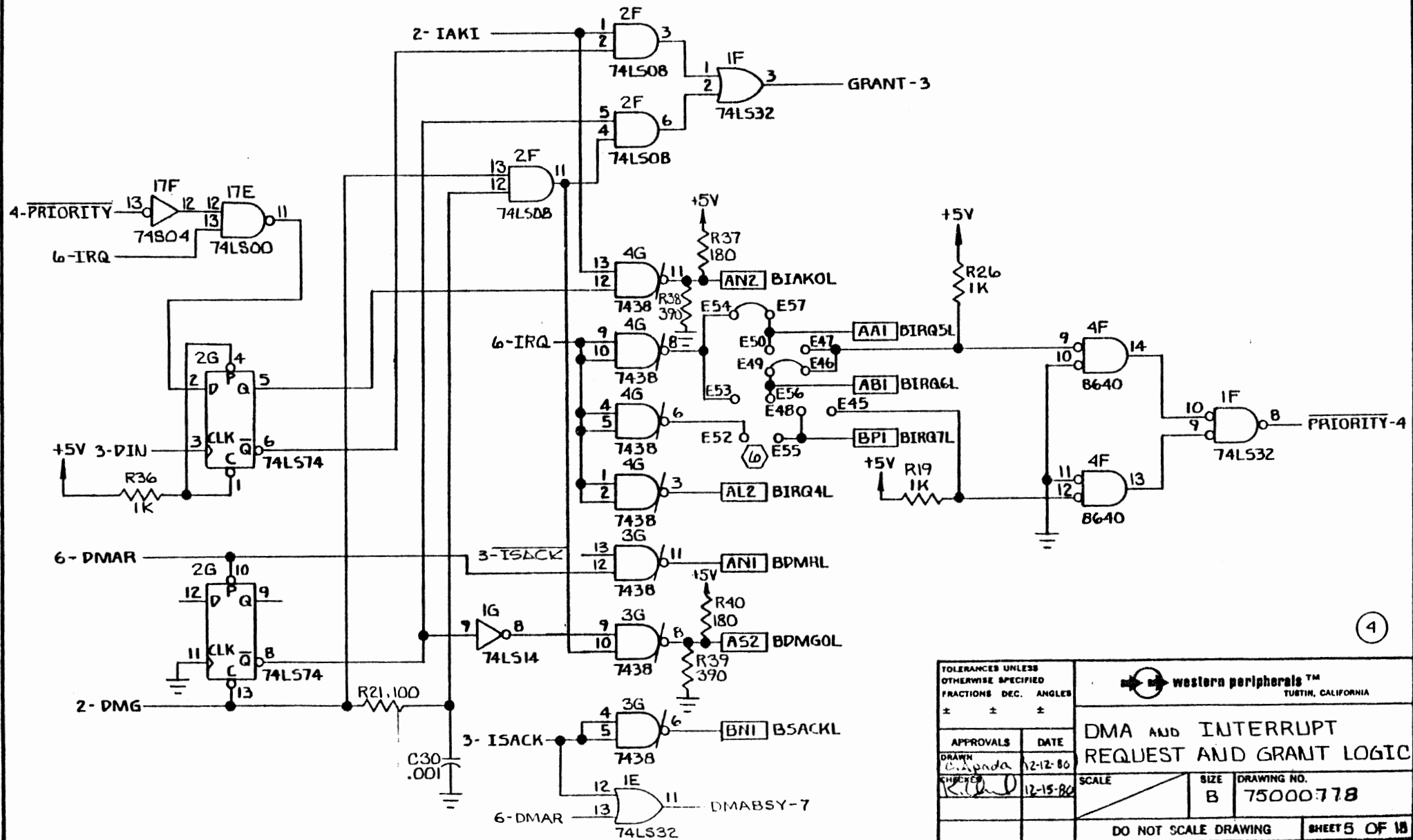

TOLERANCES UNLESS OTHERWISE SPECIFIED
FRACTIONS DEC. ANGLES
± ± ±

western peripherals™
TUSTIN, CALIFORNIA

DMA AND INTERRUPT REQUEST AND GRANT LOGIC

| | |
|------------------------|----------|
| APPROVALS | DATE |
| DRAWN C. S. S. S. | 12-12-80 |
| CHECKED C. S. S. S. | 12-15-80 |

| | | |
|-------|-----------|-------------------------|
| SCALE | SIZE B | DRAWING NO. 75000778 |
|-------|-----------|-------------------------|

DO NOT SCALE DRAWING SHEETS OF 18

4

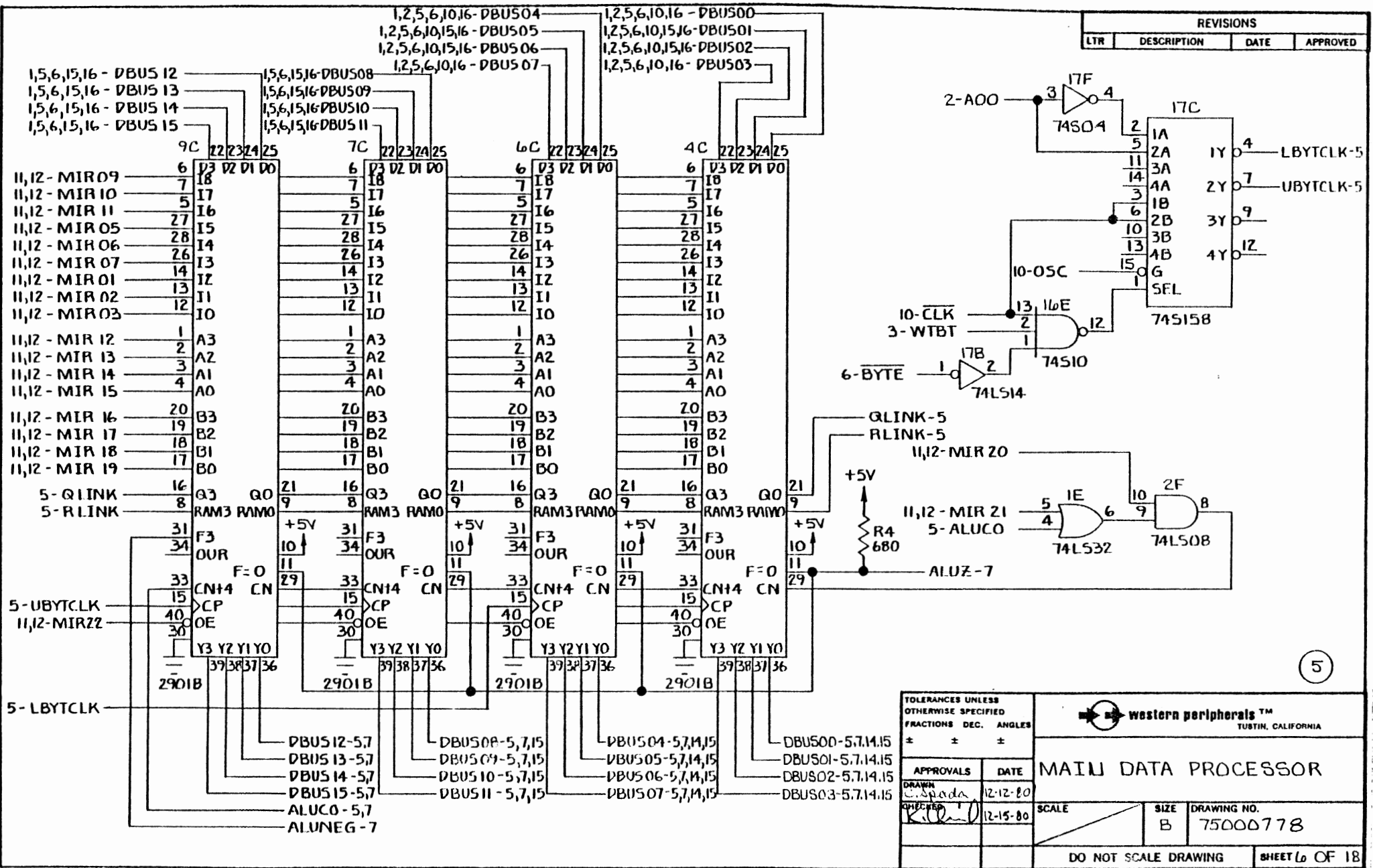

| REVISIONS | | | |
|-----------|-------------|------|----------|
| LTR | DESCRIPTION | DATE | APPROVED |
| | | | |

5

| | | | |
|---|--|--|----------------------|
| TOLERANCES UNLESS OTHERWISE SPECIFIED FRACTIONS DEC. ANGLES ± ± ± | | western peripherals™ TUBBIN, CALIFORNIA | |
| APPROVALS | | DATE | MAIL DATA PROCESSOR |
| DRAWN C. Sparda | | 12-12-80 | |
| CHECKED K. D. [Signature] | | 12-15-80 | SCALE |
| | | | SIZE B |
| | | | DRAWING NO. 75000778 |
| DO NOT SCALE DRAWING | | | SHEET 6 OF 18 |

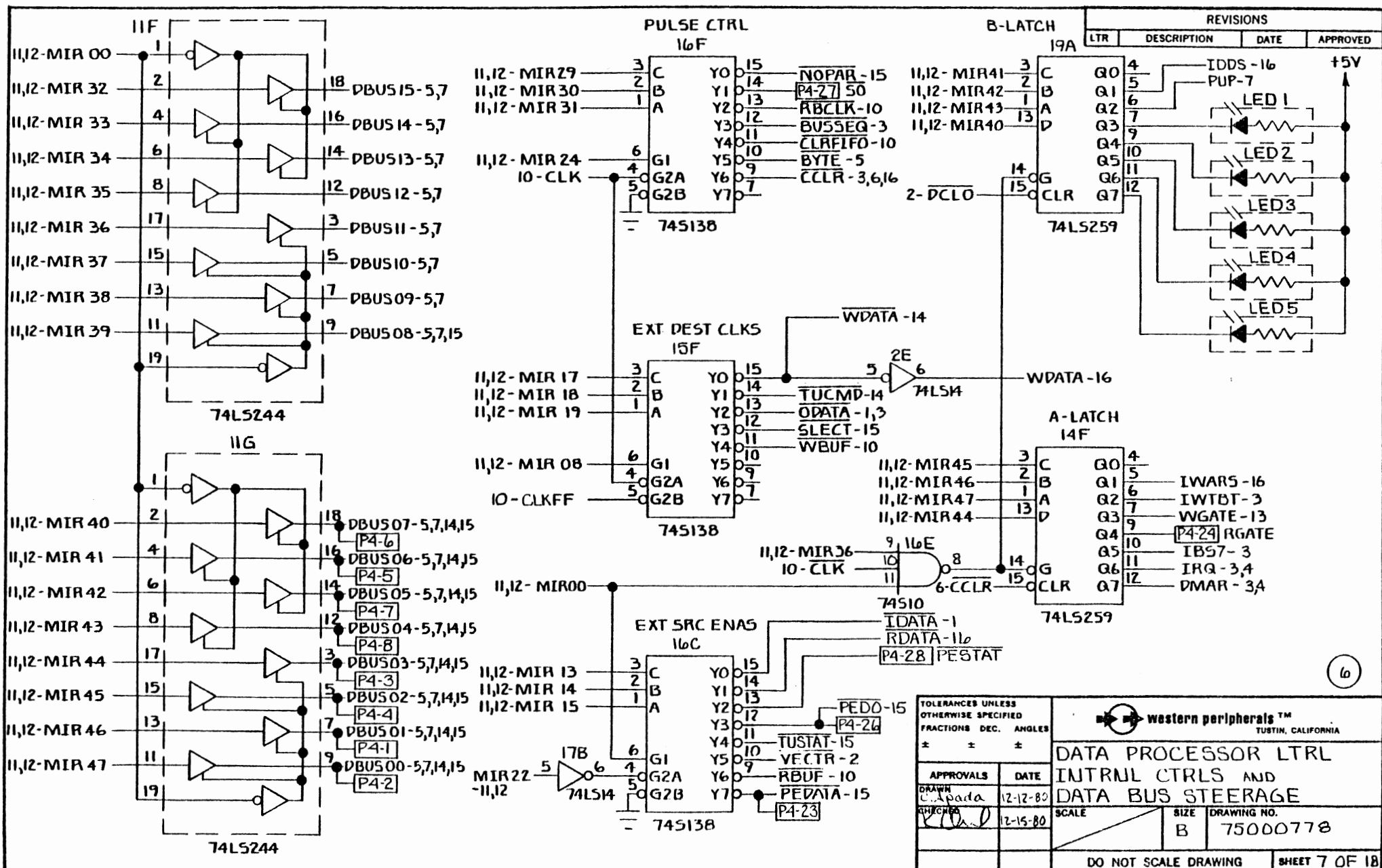

| REVISIONS | | | |
|-----------|-------------|------|----------|
| LTR | DESCRIPTION | DATE | APPROVED |

| | | | |
|---------------------------------------|------|--|---------------|
| TOLERANCES UNLESS OTHERWISE SPECIFIED | | western peripherals™ TUSTIN, CALIFORNIA | |
| FRACTIONS | DEC. | ANGLES | |
| * ± | ± | ± | |
| APPROVALS | | DATE | SCALE |
| DRAWN C. Apada | | 12-12-80 | |
| CHECKED | | DATE | SIZE |
| P. J. J. | | 12-15-80 | B |
| DRAWING NO. | | | SHEET 7 OF 18 |
| 75000778 | | | |
| DO NOT SCALE DRAWING | | | |

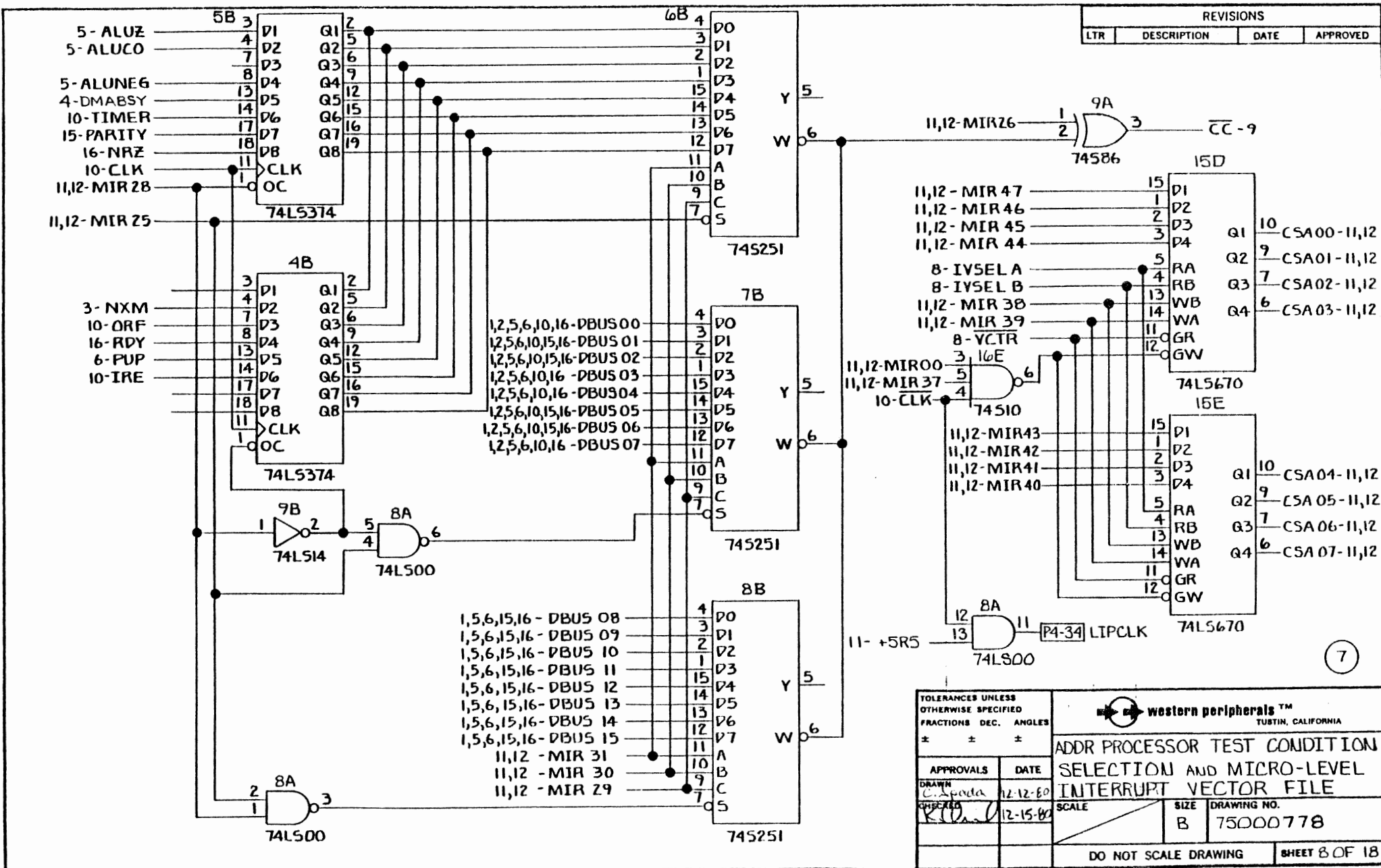

| REVISIONS | | | |
|-----------|-------------|------|----------|
| LTR | DESCRIPTION | DATE | APPROVED |

| | | | |
|---|--|--|---------------|
| TOLERANCES UNLESS OTHERWISE SPECIFIED FRACTIONS DEC. ANGLES ± ± ± | | western peripherals™ TUSTIN, CALIFORNIA | |
| APPROVALS | | DATE | |
| DRAWN C. Spada | | 12-12-80 | |
| CHECKED KID | | 12-15-80 | |
| SCALE | | SIZE | DRAWING NO. |
| | | B | 75000778 |
| DO NOT SCALE DRAWING | | | SHEET 8 OF 18 |

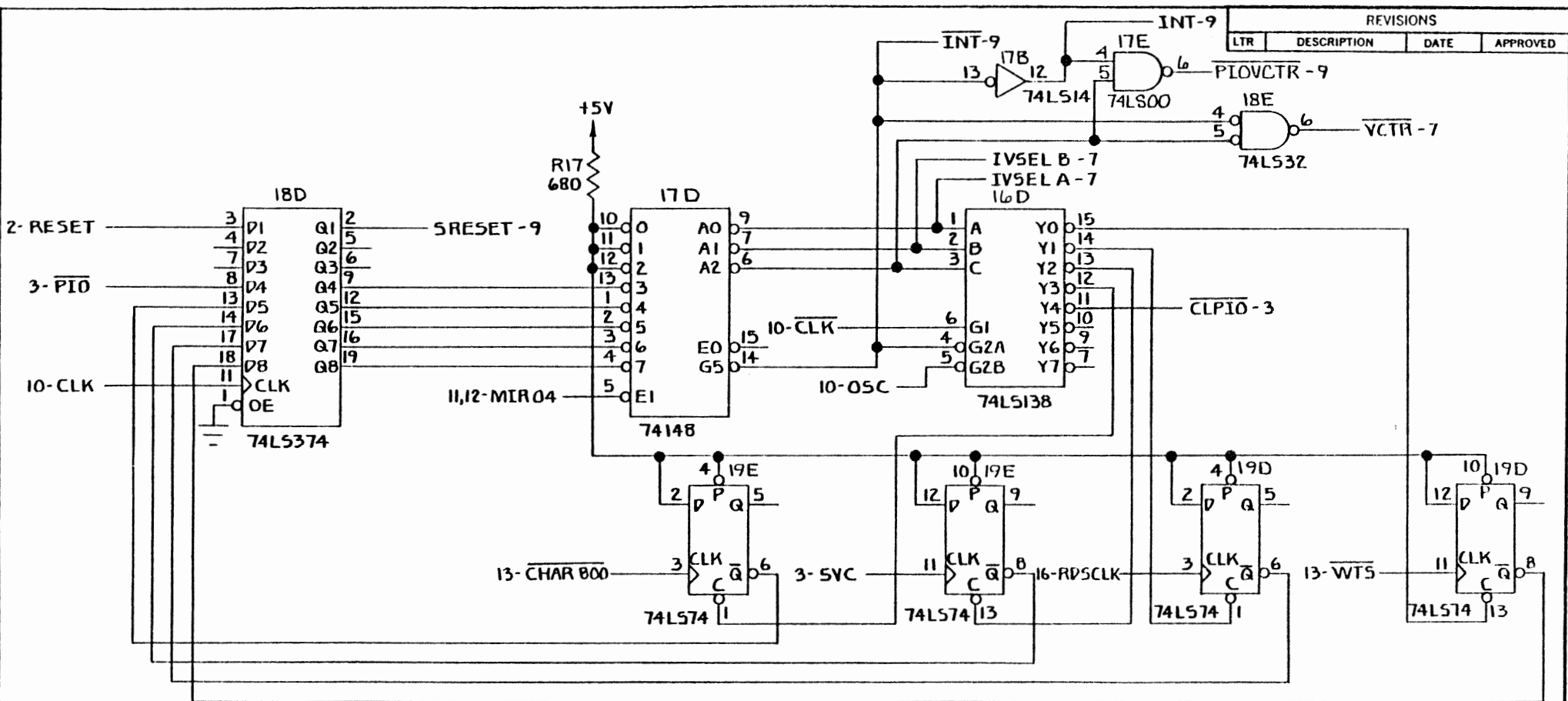

| REVISIONS | | | |
|-----------|-------------|------|----------|
| LTR | DESCRIPTION | DATE | APPROVED |
| | | | |

(8)

| | | | |
|---|------------------|---|---------------|
| TOLERANCES UNLESS OTHERWISE SPECIFIED FRACTIONS DEC. ANGLES ± ± ± | | western peripherals™ TUSTIN, CALIFORNIA | |
| APPROVALS | | MICRO-LEVEL INTERRUPT CTRL | |
| DRAWN <i>C. Spada</i> | DATE 12-12-80 | SCALE | SIZE B |
| CHECKED <i>R. [Signature]</i> | DATE 12-15-80 | DRAWING NO. 75000778 | SHEET 9 OF 18 |
| DO NOT SCALE DRAWING | | | |

| REVISIONS | | | |
|-----------|-------------|------|----------|
| LTR | DESCRIPTION | DATE | APPROVED |

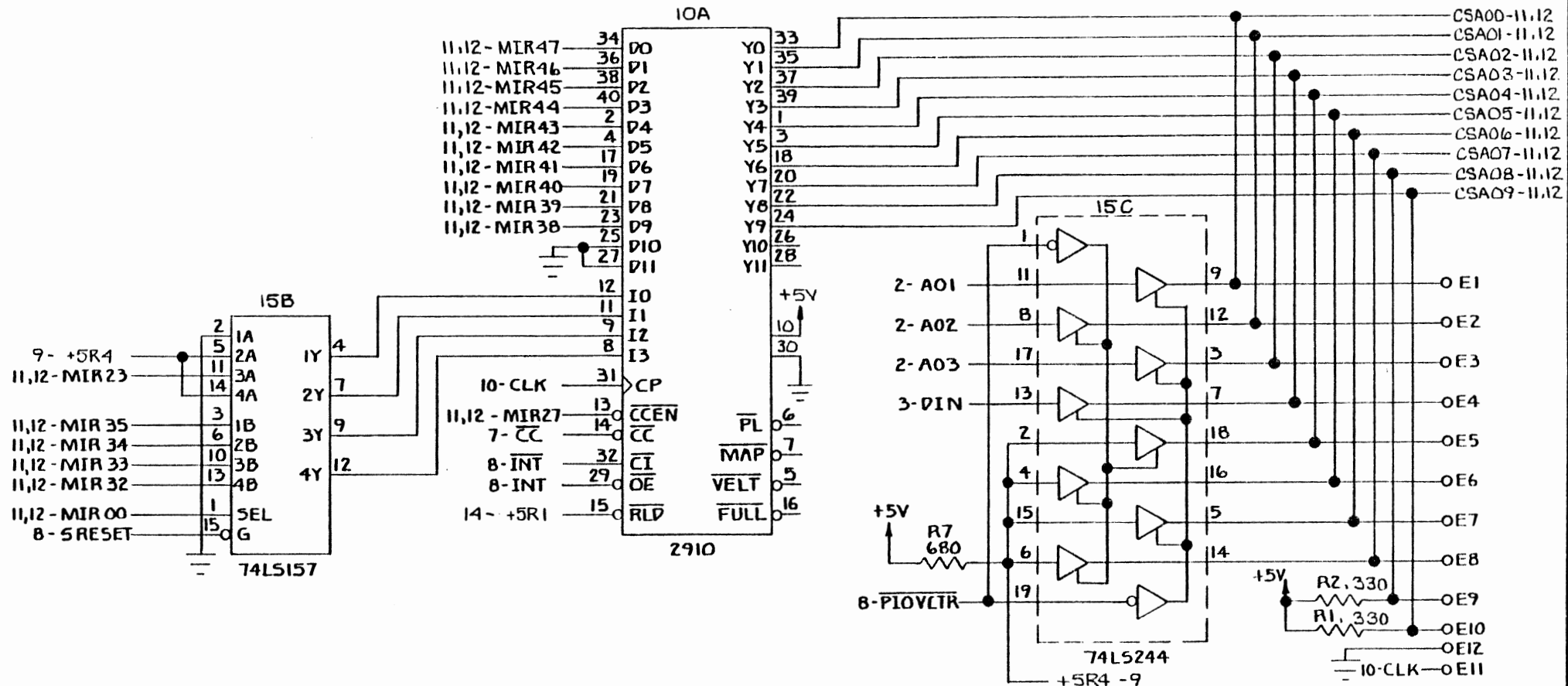

| | | | |
|--|--|--|-------------|
| | | | CSA00-11.12 |
| | | | CSA01-11.12 |
| | | | CSA02-11.12 |
| | | | CSA03-11.12 |
| | | | CSA04-11.12 |
| | | | CSA05-11.12 |
| | | | CSA06-11.12 |
| | | | CSA07-11.12 |
| | | | CSA08-11.12 |
| | | | CSA09-11.12 |

9

| | | | |
|---|--|---|----------------|
| TOLERANCES UNLESS OTHERWISE SPECIFIED FRACTIONS DEC. ANGLES ± ± ± | | western peripherals™ TUSTIN, CALIFORNIA | |
| APPROVALS DRAWN: C. Spada CHECKED: [Signature] | | ADDR PROCESSOR DATE: 12.12.80 SCALE: 12-15-80 | |
| SIZE: B | | DRAWING NO.: 75000778 | |
| DO NOT SCALE DRAWING | | | SHEET 10 OF 18 |

| REVISIONS | | | |
|-----------|-------------|------|----------|
| LTR | DESCRIPTION | DATE | APPROVED |

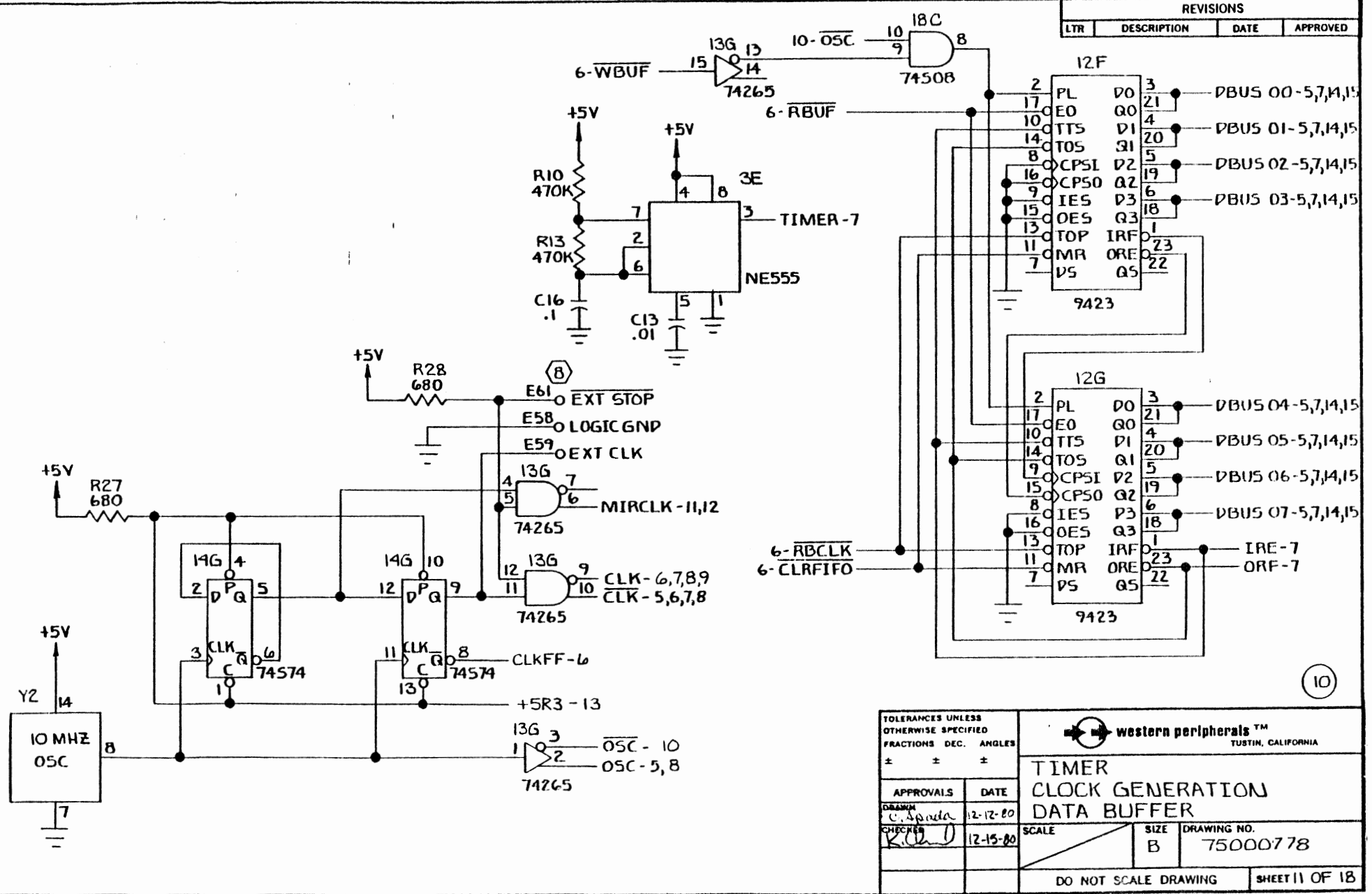

10

| | | | |
|---|--|---|----------------|
| TOLERANCES UNLESS OTHERWISE SPECIFIED FRACTIONS DEC. ANGLES ± ± ± | |  western peripherals™ TUSTIN, CALIFORNIA | |
| APPROVALS | | DATE | |
| DRAWN <i>C. Sparta</i> | | 12-12-80 | |
| CHECKED <i>R. D.</i> | | 12-15-80 | |
| SCALE | | SIZE | DRAWING NO. |
| | | B | 75000778 |
| DO NOT SCALE DRAWING | | | SHEET 11 OF 18 |

| REVISIONS | | | |
|-----------|-------------|------|----------|
| LTR | DESCRIPTION | DATE | APPROVED |

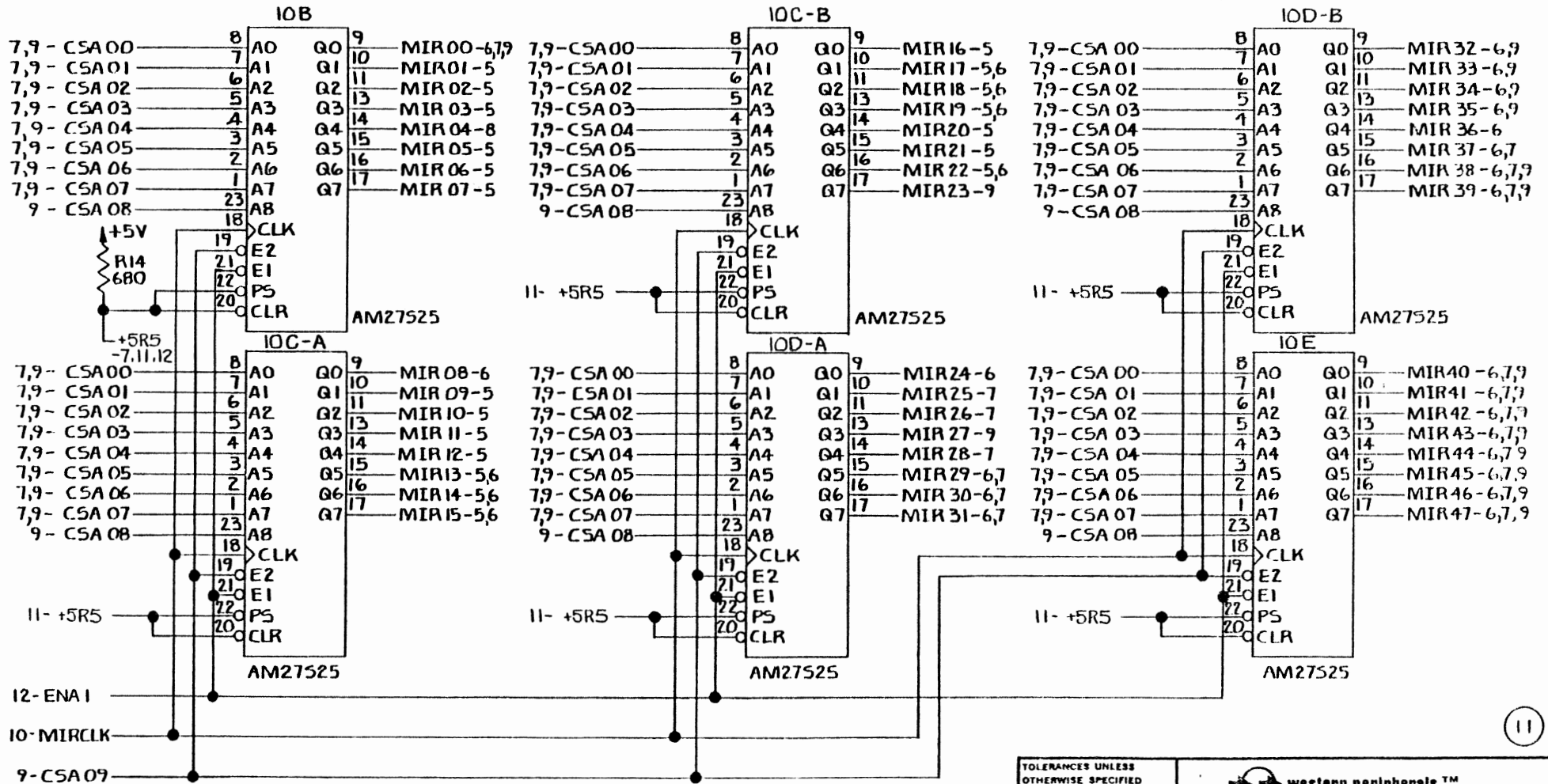

| | | | |
|---------------------------------------|----------|--|----------------------------|
| TOLERANCES UNLESS OTHERWISE SPECIFIED | | western peripherals™ TUSTIN, CALIFORNIA | |
| FRACTIONS | DEC. | | |
| ± | ± | ± | CONTROL STORE 0-511 |
| APPROVALS | DATE | SCALE | |
| DRAWN C. Apada | 12-12-80 | SIZE B | |
| CHECKED K. J. | 12-15-80 | DRAWING NO. 75000778 | |
| DO NOT SCALE DRAWING | | | SHEET 12 OF 18 |

| REVISIONS | | | |
|-----------|-------------|------|----------|
| LTR | DESCRIPTION | DATE | APPROVED |

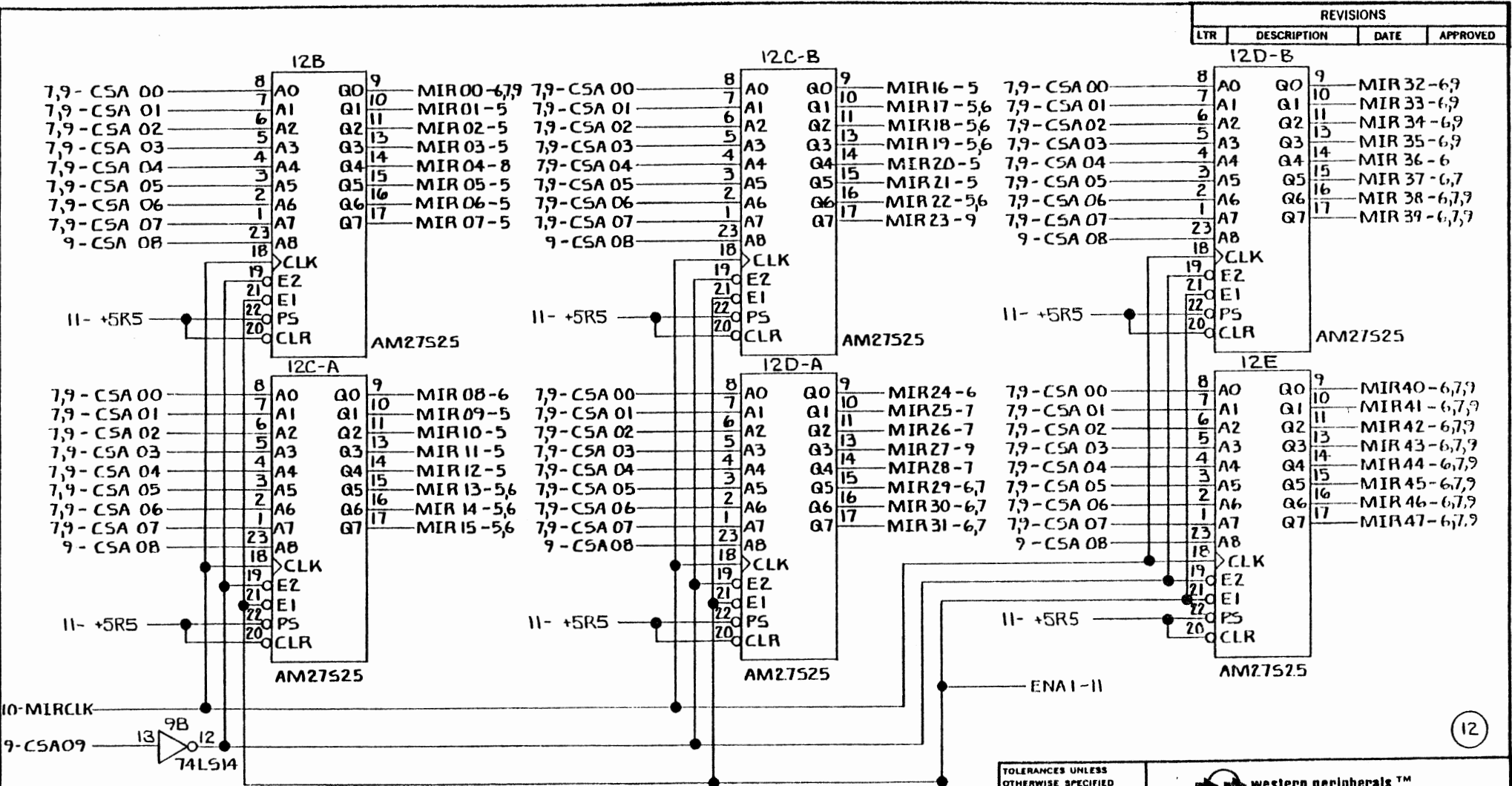

12

| | | | |
|--|----------|--|-------------------------------|
| TOLERANCES UNLESS OTHERWISE SPECIFIED | | western peripherals™ TUSTIN, CALIFORNIA | |
| FRACTIONS | DEC. | | |
| ± | ± | ± | CONTROL STORE 512-1023 |
| APPROVALS | DATE | SCALE | |
| DRAWN <i>C. Spada</i> CHECKED <i>K. [Signature]</i> | 12-15-80 | B | |
| DO NOT SCALE DRAWING | | SIZE | DRAWING NO. |
| | | B | 75000778 |
| | | | SHEET 13 OF 18 |

| REVISIONS | | | |
|-----------|-------------|------|----------|
| LTR | DESCRIPTION | DATE | APPROVED |
| | | | |

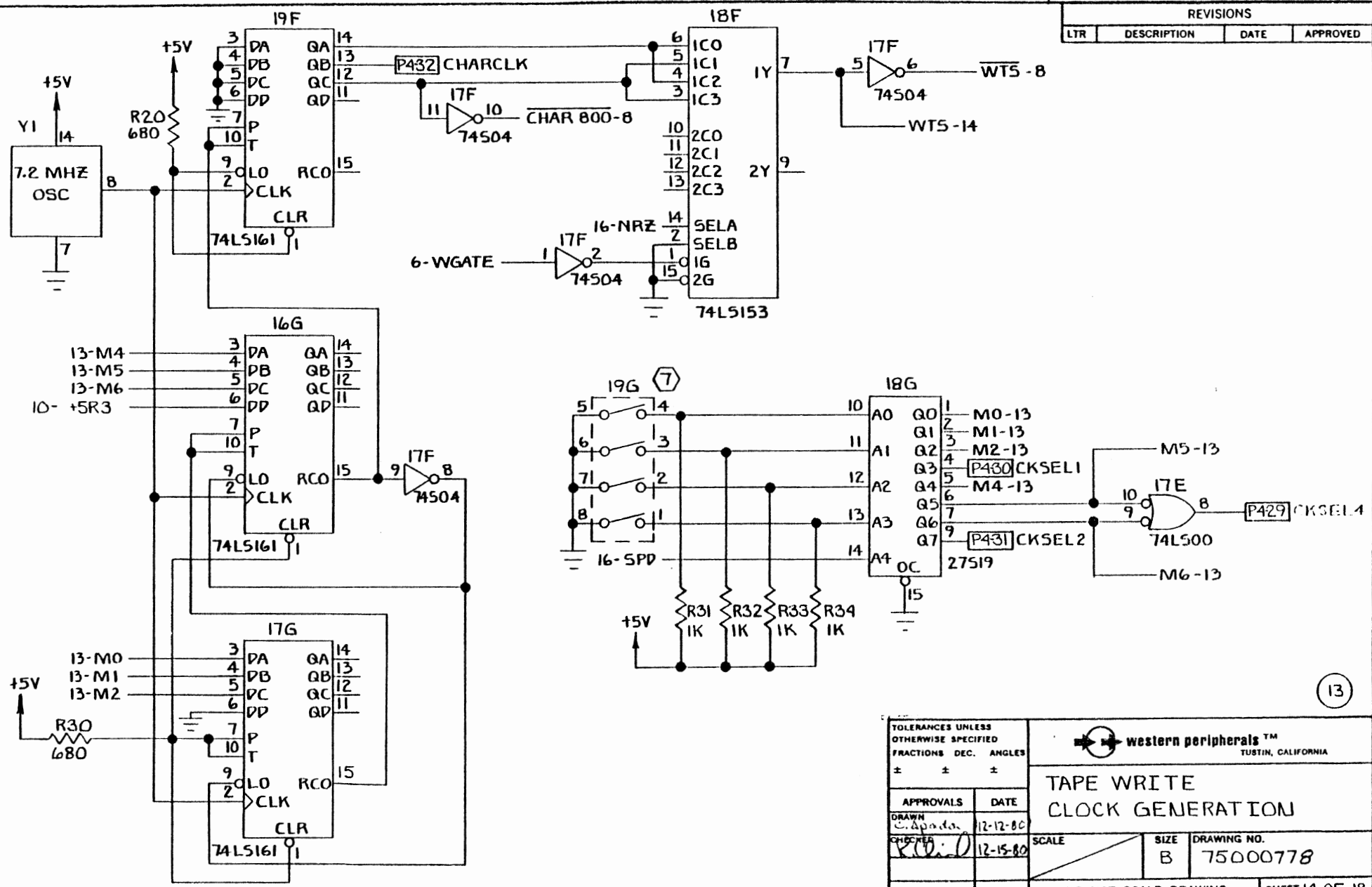

13

| | | | |
|---------------------------------------|----------|---|--|
| TOLERANCES UNLESS OTHERWISE SPECIFIED | | western peripherals™ TUSTIN, CALIFORNIA | |
| FRACTIONS | DEC. | | |
| ± | ± | ± | TAPE WRITE CLOCK GENERATION |
| APPROVALS | DATE | SCALE | |
| DRAWN C. Appada | 12-12-80 | SIZE B | |
| CHECKED R. D. | 12-15-80 | DRAWING NO. 75000778 | |
| DO NOT SCALE DRAWING | | | SHEET 14 OF 18 |

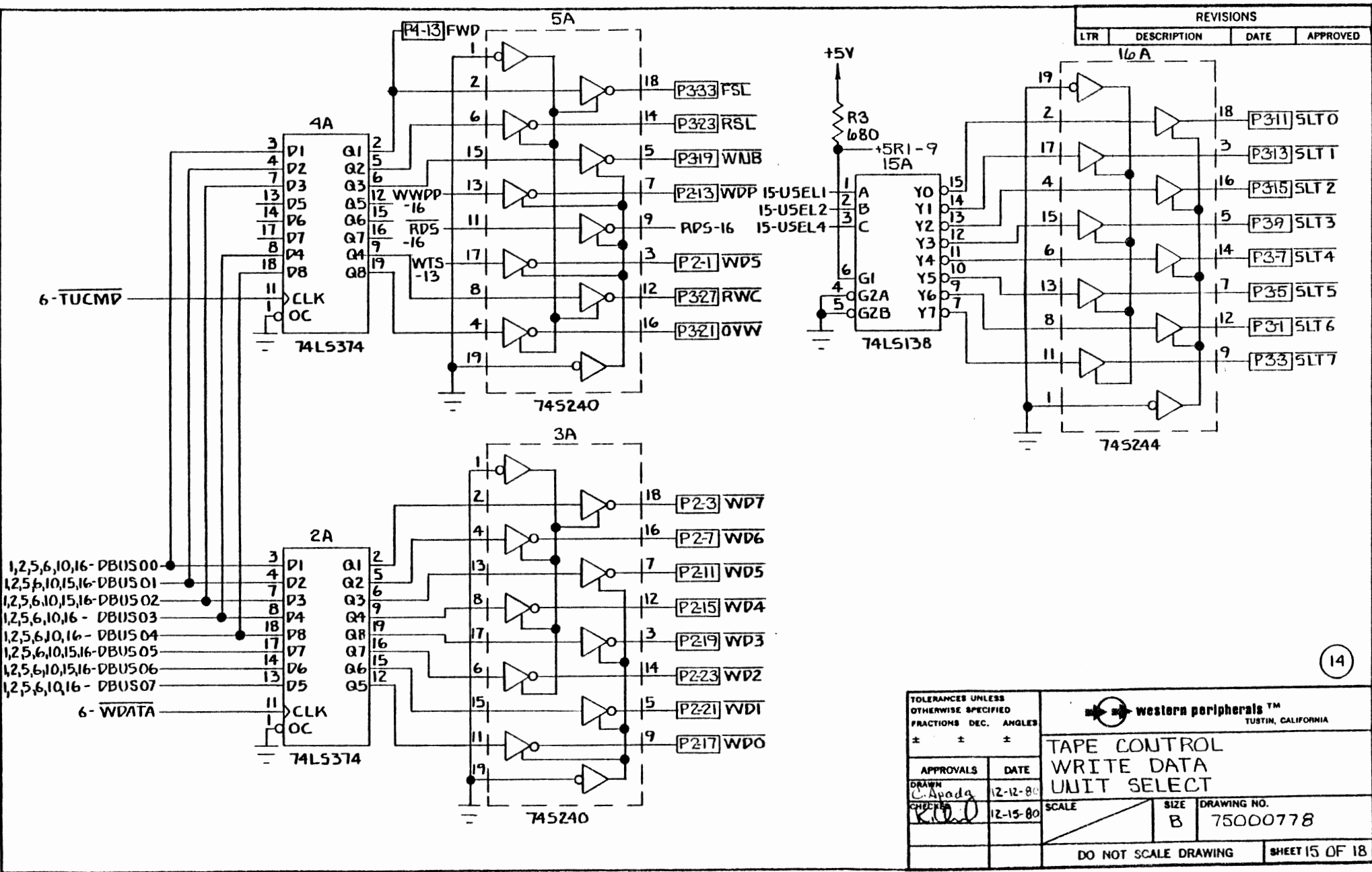

| REVISIONS | | | |
|-----------|-------------|------|----------|
| LTR | DESCRIPTION | DATE | APPROVED |

14

| | | | |
|---|--|--|----------------------|
| TOLERANCES UNLESS OTHERWISE SPECIFIED FRACTIONS DEC. ANGLES | | western peripherals™ TUSTIN, CALIFORNIA | |
| APPROVALS | | DATE | |
| DRAWN C. Apada | | 12-12-80 | |
| CHECKED K.O. | | 12-15-80 | |
| SCALE | | SIZE B | DRAWING NO. 75000778 |
| DO NOT SCALE DRAWING | | | SHEET 15 OF 18 |

| REVISIONS | | | |
|-----------|-------------|------|----------|
| LTR | DESCRIPTION | DATE | APPROVED |

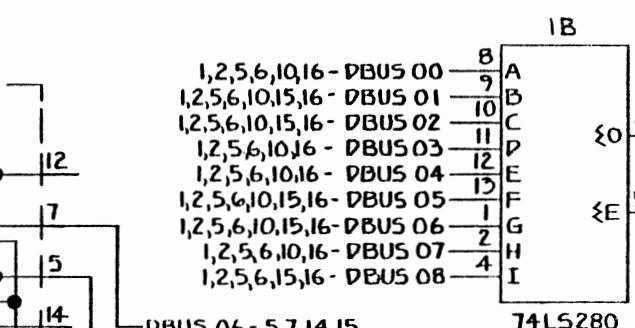
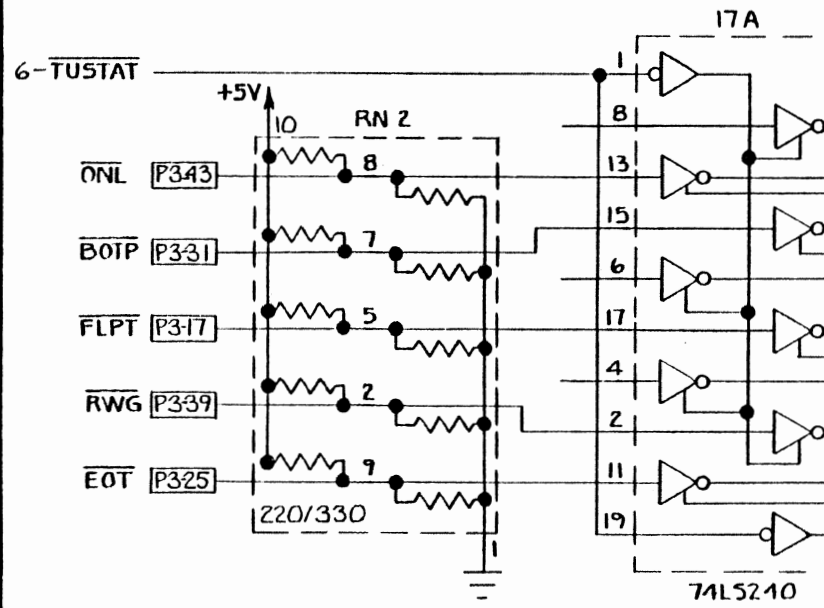
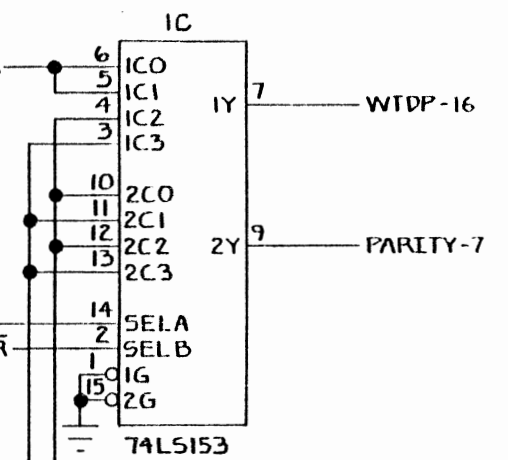
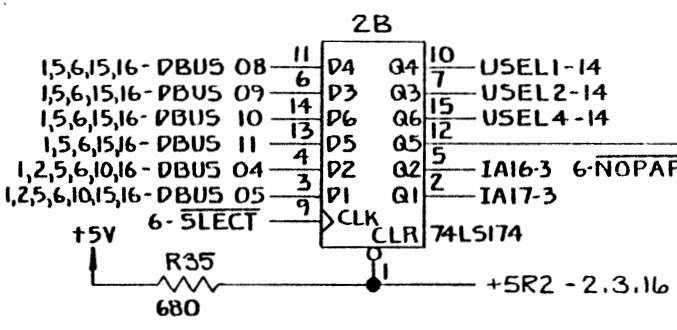
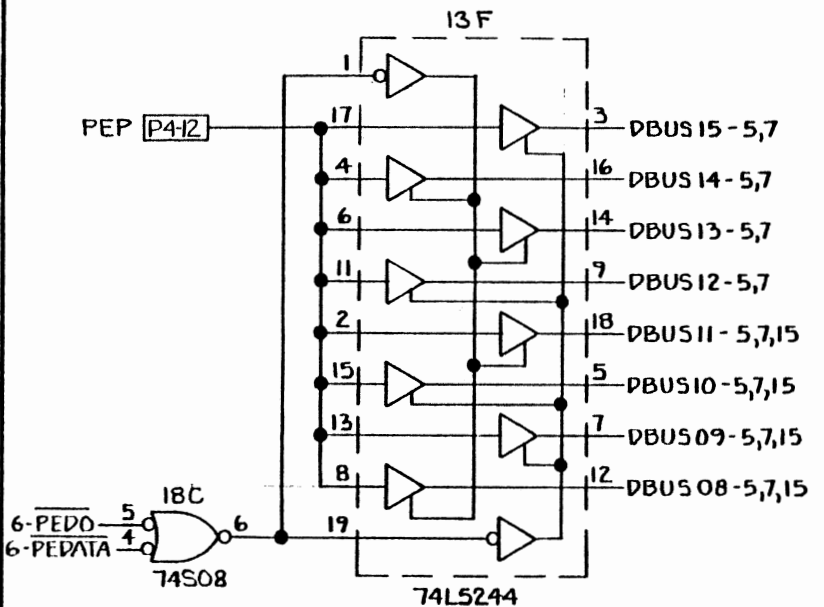

15

| | | | |
|--|----------|---|----------------------|
| TOLERANCES UNLESS OTHERWISE SPECIFIED FRACTIONS DEC. ANGLES | | western peripherals™ TUBSTIN, CALIFORNIA | |
| APPROVALS | DATE | TAPE STATUS | |
| DRAWN C. Spoda | 12-12-80 | PARITY DETECTION AND GENERATION | |
| CHECKED R. [Signature] | 12-15-80 | SCALE | SIZE B |
| | | | DRAWING NO. 75000778 |
| DO NOT SCALE DRAWING | | | SHEET 16 OF 18 |

504109-A

| REVISIONS | | | |
|-----------|-------------|------|----------|
| LTR | DESCRIPTION | DATE | APPROVED |

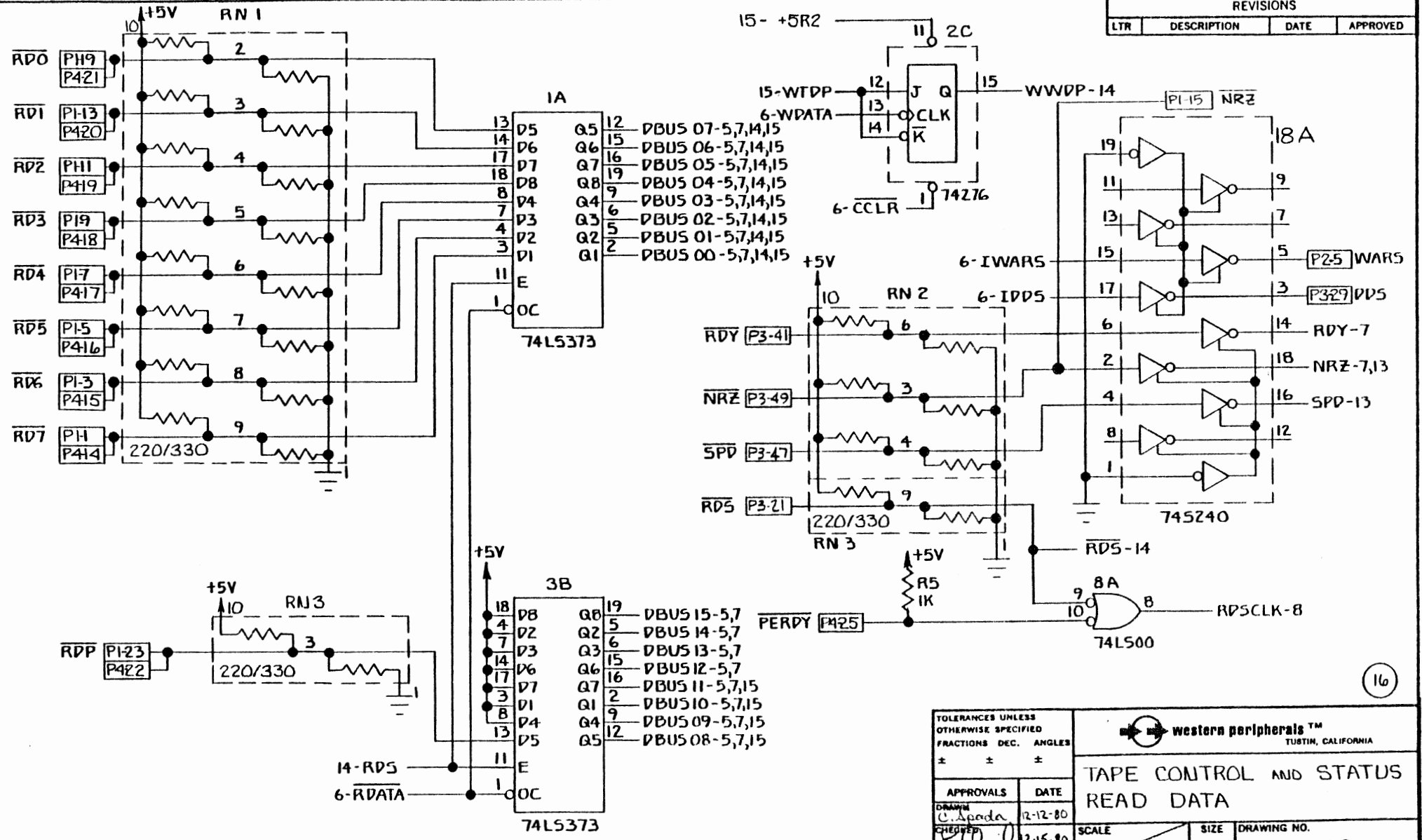

| | |
|---|----------|
| TOLERANCES UNLESS OTHERWISE SPECIFIED FRACTIONS DEC. ANGLES | |
| ± | ± |
| APPROVALS | DATE |
| DRAWN C. Spada | 12-12-80 |
| CHECKED K. O. | 12-15-80 |

western peripherals™
TUSTIN, CALIFORNIA

TAPE CONTROL AND STATUS
READ DATA

| | | |
|-------|------|-------------|
| SCALE | SIZE | DRAWING NO. |
| | B | 75000778 |

DO NOT SCALE DRAWING SHEET 17 OF 18

| REVISIONS | | | |
|-----------|-------------|------|----------|
| LTR | DESCRIPTION | DATE | APPROVED |

4

DEVICE ADDRESS
STD ADDR 772520_B

| ADDR BIT | ADDR RANGE | E JUMPERS | STD ADDR | INSTALLED JUMPERS |
|----------|------------|-----------|----------|-------------------|
| 17 | | | | |
| 16 | | | | |
| 15 | | | | |
| 14 | | | | |
| 13 | | | | |
| 12 | 0/1 | 13-21 | | |
| 11 | 0/1 | 14-22 | 0 | 14-22 |
| 10 | 0/1 | 15-23 | | |
| 9 | 0/1 | 16-24 | 0 | 16-24 |
| 8 | 0/1 | 17-25 | | |
| 7 | 0/1 | 18-26 | 0 | 18-26 |
| 6 | 0/1 | 19-27 | | |
| 5 | 0/1 | 20-28 | 0 | 20-28 |
| 4 | 0/1 | 62-63 | | |
| 3 | X | | X | |
| 2 | X | | X | |
| 1 | X | | X | |
| 0 | X | | X | |

6

INTERRUPT PRIORITY LEVEL

| BR4 | BR5 | BR6 | BR7 |
|-----------|-----------|-----------|-----------|
| E46 → E49 | E46 → E49 | E45 → E48 | E52 → E55 |
| E47 → E50 | E54 → E57 | E53 → E56 | E53 → E56 |

5

INTERRUPT VECTOR
STD VECTOR 224_B

| VCTR BIT | E JUMPERS | STD VCTR | INSTALLED JUMPERS |
|----------|-----------|----------|-------------------|
| 7 | 29-35 | | |
| 6 | 30-36 | 0 | 30-36 |
| 5 | 31-37 | 0 | 31-37 |
| 4 | 32-38 | | |
| 3 | 33-39 | 0 | 33-39 |
| 2 | 34-40 | | |
| 1 | | 0 | |
| 0 | | 0 | |

7

SPEED SETTING

| SW POS | 125 | 125 | 125 | 125 | 75 | 75 | 75 | 45 | 45 | 37.5 | SELB |
|--------|-----|-----|------|-----|----|------|----|------|----|------|------|
| 196 | 75 | 45 | 37.5 | 25 | 45 | 37.5 | 25 | 37.5 | 25 | 25 | SELA |
| 1 | C | C | C | C | C | C | C | 0 | 0 | 0 | |
| 2 | C | C | C | C | 0 | 0 | 0 | C | C | 0 | |
| 3 | C | C | 0 | 0 | C | 0 | 0 | C | 0 | C | |
| 4 | C | 0 | 0 | 0 | 0 | C | 0 | 0 | C | C | |

TAPE
CTRL
CBL
SWA-4

C=ON
O=OFF

| | | | |
|---|--|---|-------------------------|
| TOLERANCES UNLESS OTHERWISE SPECIFIED FRACTIONS DEC. ANGLES ± ± ± | |  western peripherals™ TUSTIN, CALIFORNIA | |
| APPROVALS <i>[Signature]</i> | | DATE 12-18-80 | |
| CHECKED HD KOGA | | DATE 12-18-80 | |
| SCALE | | SIZE B | DRAWING NO. 75000778 |
| DO NOT SCALE DRAWING | | | SHEET 18 OF 18 |

| REVISIONS | | | |
|-----------|-----------------------------|---------|------------|
| LTR | DESCRIPTION | DATE | APPROVED |
| A | RELEASE | 3-2-81 | <i>DRZ</i> |
| A1 | RECORD CHG PG. 4136 8370 | 7-17-81 | <i>CMY</i> |
| B | REV PER ECO 1072 | 5-6-82 | <i>DRZ</i> |

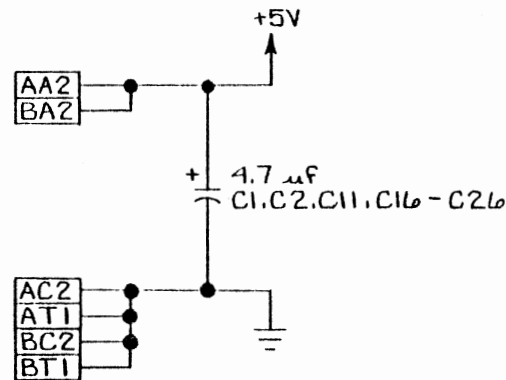

INTERCONNECT

| | | P4 | | | |
|--------|----|----|---------|--|--|
| DBUS01 | 1 | 2 | DBUS00 | | |
| DBUS03 | 3 | 4 | DBUS02 | | |
| DBUS06 | 5 | 6 | DBUS07 | | |
| DBUS05 | 7 | 8 | DBUS04 | | |
| GND | 9 | 10 | GND | | |
| | 11 | 12 | PEP | | |
| FWD | 13 | 14 | RD7 | | |
| RD6 | 15 | 16 | RD5 | | |
| RD4 | 17 | 18 | RD3 | | |
| RD2 | 19 | 20 | RD1 | | |
| RD0 | 21 | 22 | RDP | | |
| PEDATA | 23 | 24 | RDGATE | | |
| PERDY | 25 | 26 | PED0 | | |
| SO | 27 | 28 | PESTAT | | |
| CKSEL4 | 29 | 30 | CKSEL1 | | |
| CKSEL2 | 31 | 32 | CHARCLK | | |
| GND | 33 | 34 | PCLK | | |

| LAST DESIGNATION USED | |
|-----------------------|-----|
| RESISTOR | R24 |
| CAPACITOR | C27 |
| DIODE | CR8 |

3. REFERENCE ASSY. 60000874.
 2. CAPACITOR VALUES ARE IN MICROFARADS.
 1. RESISTANCE VALUES ARE IN OHMS.
- NOTES : UNLESS OTHERWISE SPECIFIED

| | | | |
|---|----------|---|------------------|
| TOLERANCES UNLESS OTHERWISE SPECIFIED FRACTIONS DEC. ANGLES ± ± ± | |  western peripherals™ TUSTIN, CALIFORNIA | |
| SCHEMATIC | | TC 151 PE ADAPTER | |
| APPROVALS | DATE | SCALE | SIZE DRAWING NO. |
| DRAWN <i>C. Guada</i> | 12-24-80 | / | B 15000786 |
| CHECKED <i>HDY/24A</i> | 12-24-80 | | |
| DO NOT SCALE DRAWING | | SHEET 1 OF 10 | |

| REVISIONS | | | |
|-----------|-------------|------|----------|
| LTR | DESCRIPTION | DATE | APPROVED |

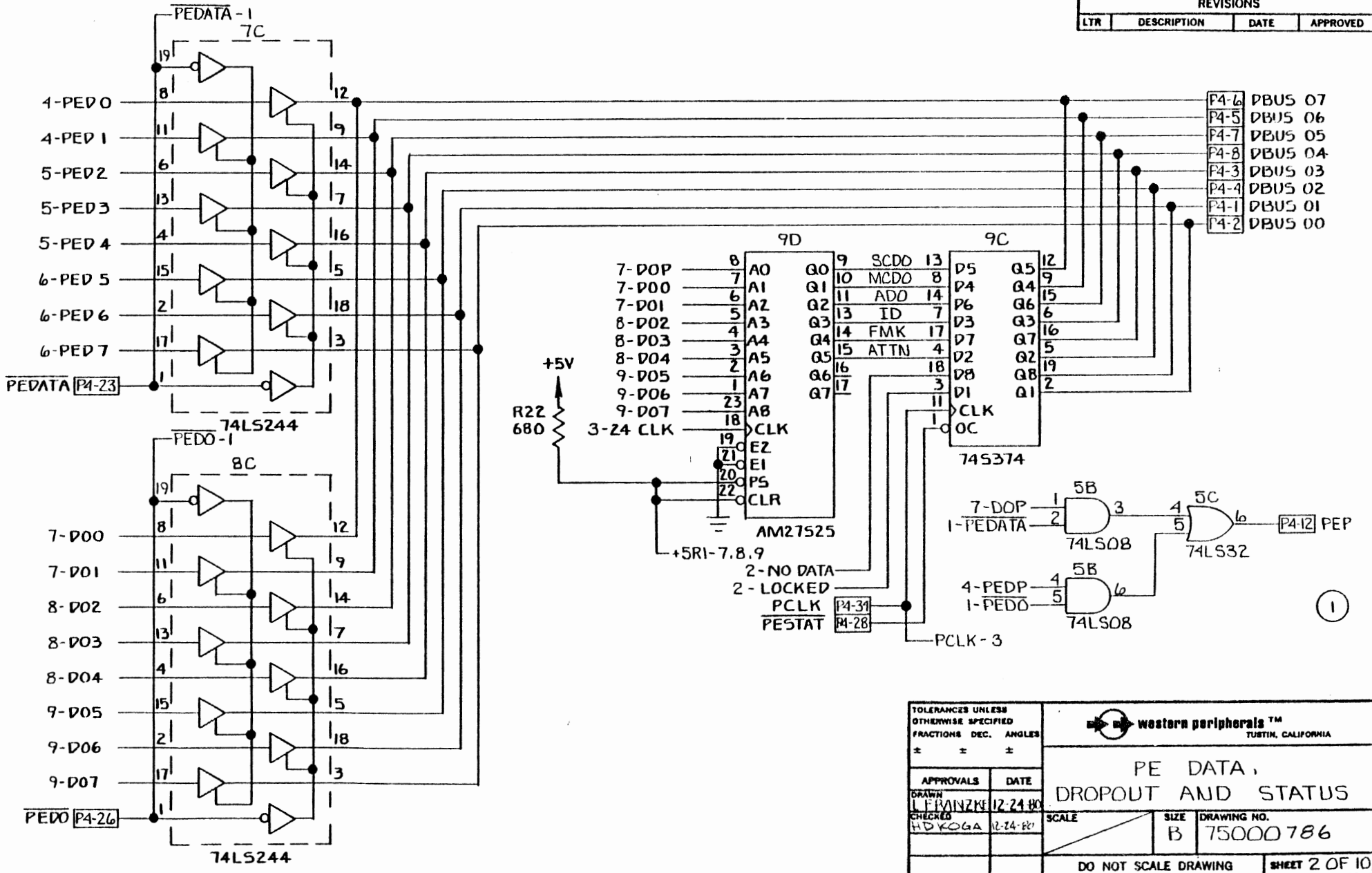

| | |
|------|---------|
| P4-6 | DBUS 07 |
| P4-5 | DBUS 06 |
| P4-7 | DBUS 05 |
| P4-8 | DBUS 04 |
| P4-3 | DBUS 03 |
| P4-4 | DBUS 02 |
| P4-1 | DBUS 01 |
| P4-2 | DBUS 00 |

| | | | |
|---|--|--|----------------------|
| TOLERANCES UNLESS OTHERWISE SPECIFIED FRACTIONS DEC. ANGLES ± ± ± | | western peripherals™ TUSTIN, CALIFORNIA | |
| APPROVALS DRAWN L. F. FINZKE CHECKED H. D. KOGA | | DATE 12-24-80 | |
| SCALE | | SIZE B | DRAWING NO. 75000786 |
| DO NOT SCALE DRAWING | | | SHEET 2 OF 10 |

| REVISIONS | | | |
|-----------|-------------|------|----------|
| LTR | DESCRIPTION | DATE | APPROVED |
| | | | |

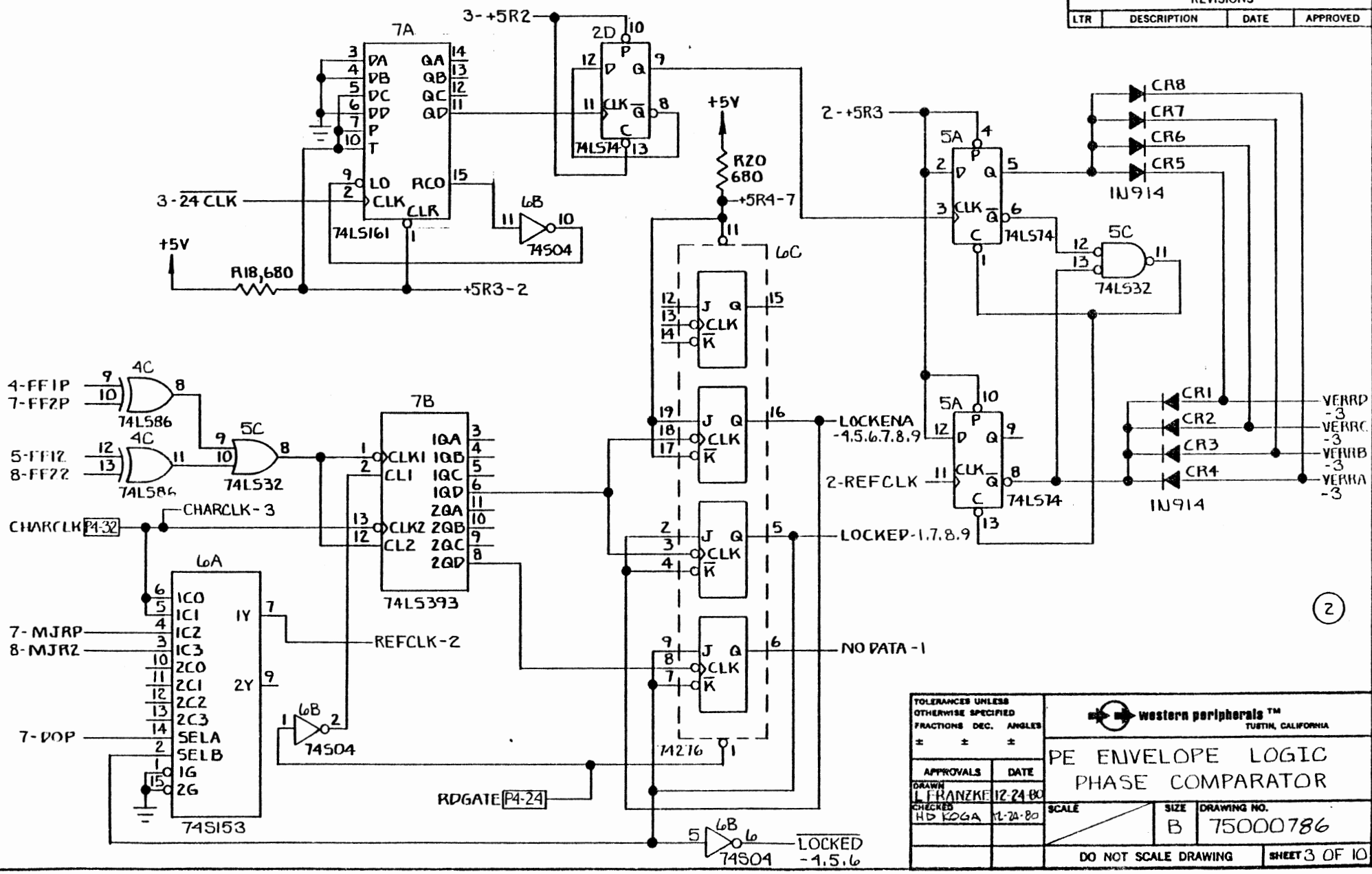

(2)

| | | | |
|---|--|---|-------------------------|
| TOLERANCES UNLESS OTHERWISE SPECIFIED FRACTIONS DEC. ANGLES ± ± ± | | western peripherals™ TUSTIN, CALIFORNIA | |
| APPROVALS | | DATE | |
| DRAWN L. FRANZKE | | 12-24-80 | |
| CHECKED HD KOGA | | 12-24-80 | |
| SCALE | | SIZE B | DRAWING NO. 75000786 |
| DO NOT SCALE DRAWING | | | SHEET 3 OF 10 |

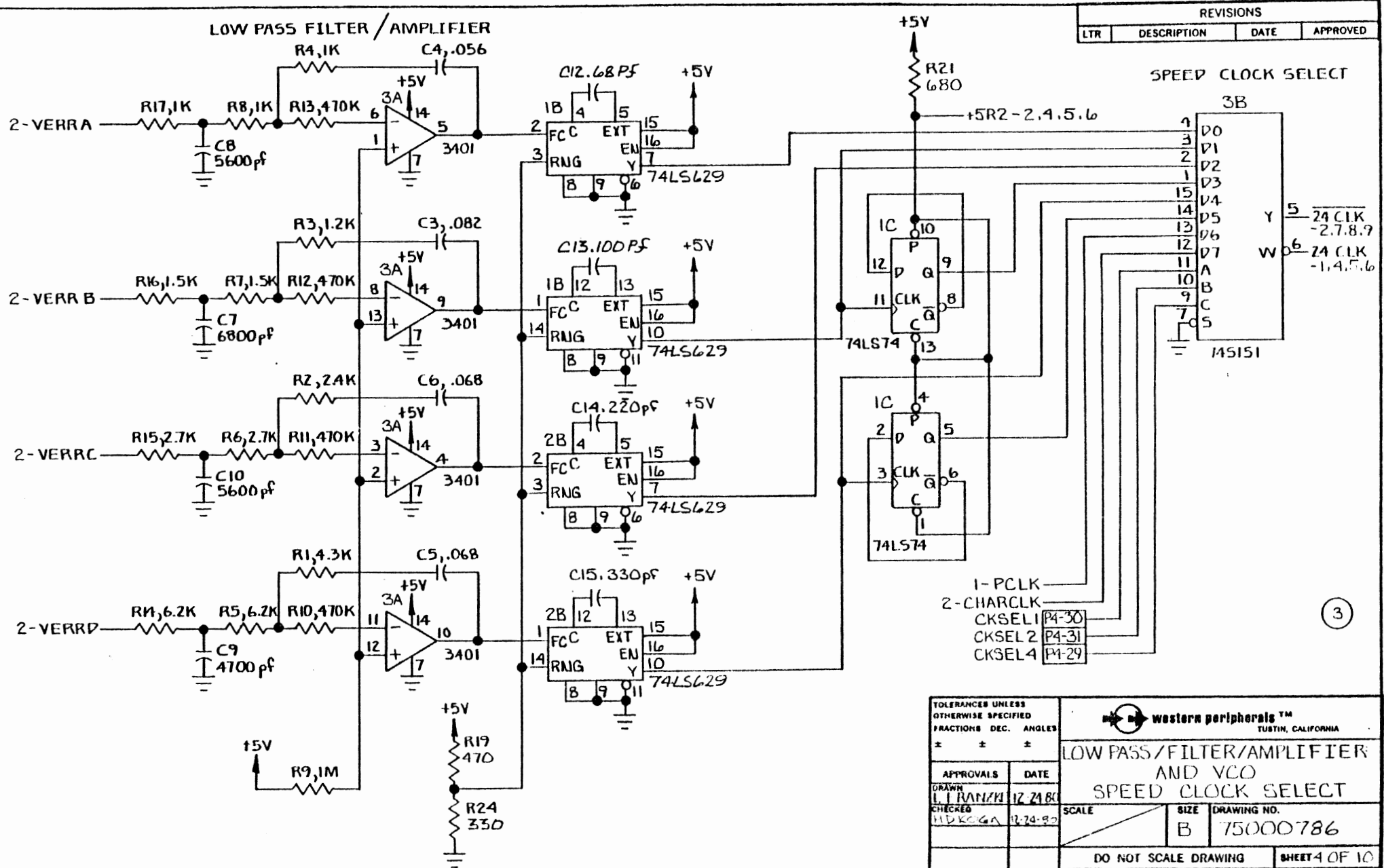

| REVISIONS | | | |
|-----------|-------------|------|----------|
| LTR | DESCRIPTION | DATE | APPROVED |

SPEED CLOCK SELECT

- 1- PCLK
- 2- CHARCLK
- CKSEL1 P4-30
- CKSEL2 P4-31
- CKSEL4 P1-29

(3)

| | | | | |
|--|----------|--|---------------|--|
| TOLERANCES UNLESS OTHERWISE SPECIFIED FRACTIONS DEC. ANGLES | | western peripherals™ TUSTIN, CALIFORNIA | | |
| ± | ± | | | LOW PASS/FILTER/AMPLIFIER AND VCO SPEED CLOCK SELECT |
| APPROVALS | DATE | SCALE | SIZE | DRAWING NO. |
| DRAWN L.I. MAN/WH | 12-21-80 | | B | 750000786 |
| CHECKED HDK/CGA | 12-24-80 | | | |
| DO NOT SCALE DRAWING | | | SHEET 4 OF 10 | |

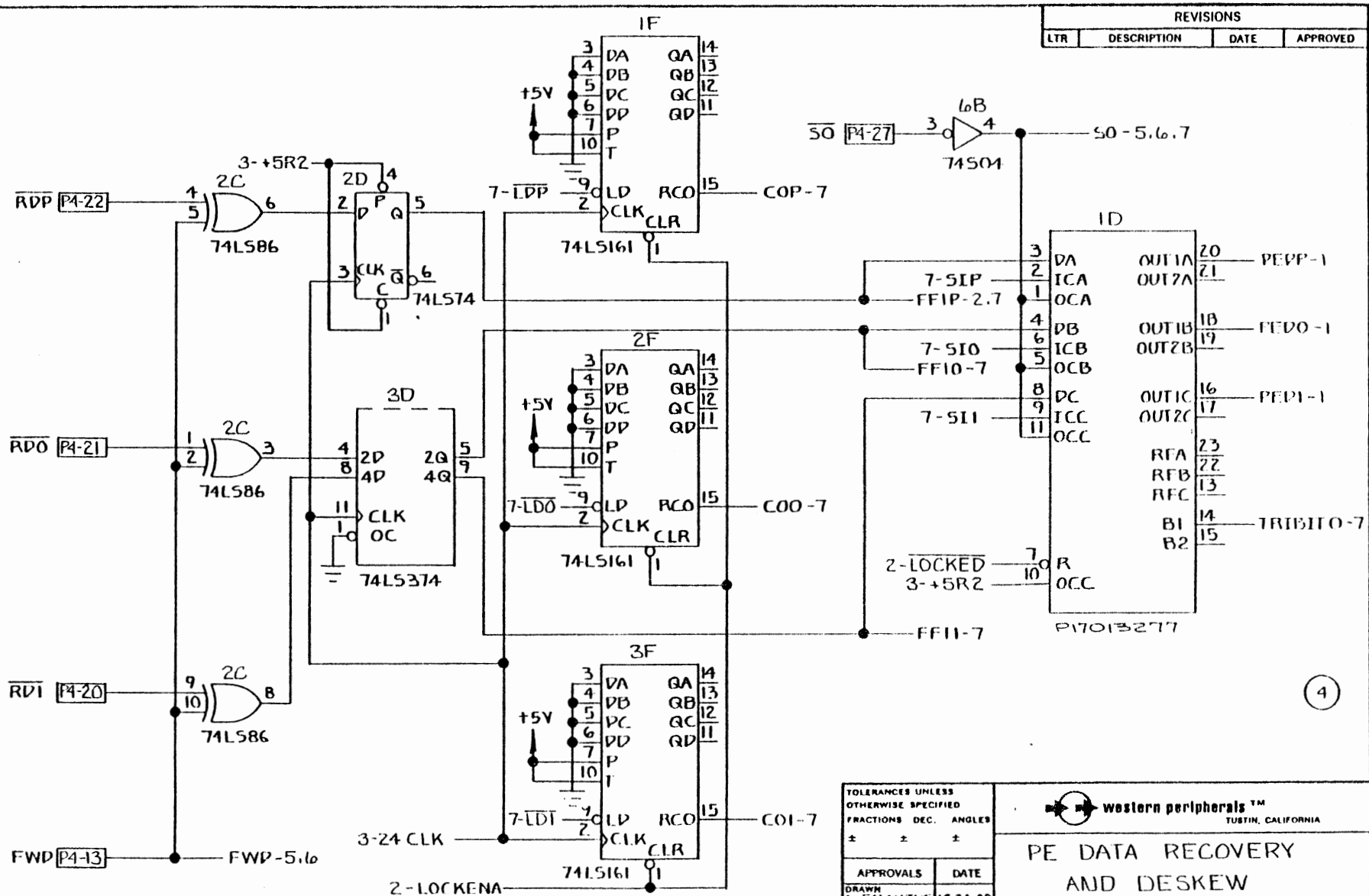

| REVISIONS | | | |
|-----------|-------------|------|----------|
| LTR | DESCRIPTION | DATE | APPROVED |

| | | | | | | |
|---|--|--|--|--------------------------------|--|---------------|
| TOLERANCES UNLESS OTHERWISE SPECIFIED FRACTIONS DEC. ANGLES ± ± ± | | western peripherals™ TUSTIN, CALIFORNIA | | | | |
| APPROVALS | | | | DATE | | |
| DRAWN L. FRANZKE | | 12-24-80 | | PE DATA RECOVERY AND DESKEW | | |
| CHECKED HD KOGA | | 12-24-80 | | | | SCALE |
| | | | | DO NOT SCALE DRAWING | | SHEET 5 OF 10 |

504110 A

| REVISIONS | | | |
|-----------|-------------|------|----------|
| LTR | DESCRIPTION | DATE | APPROVED |
| | | | |

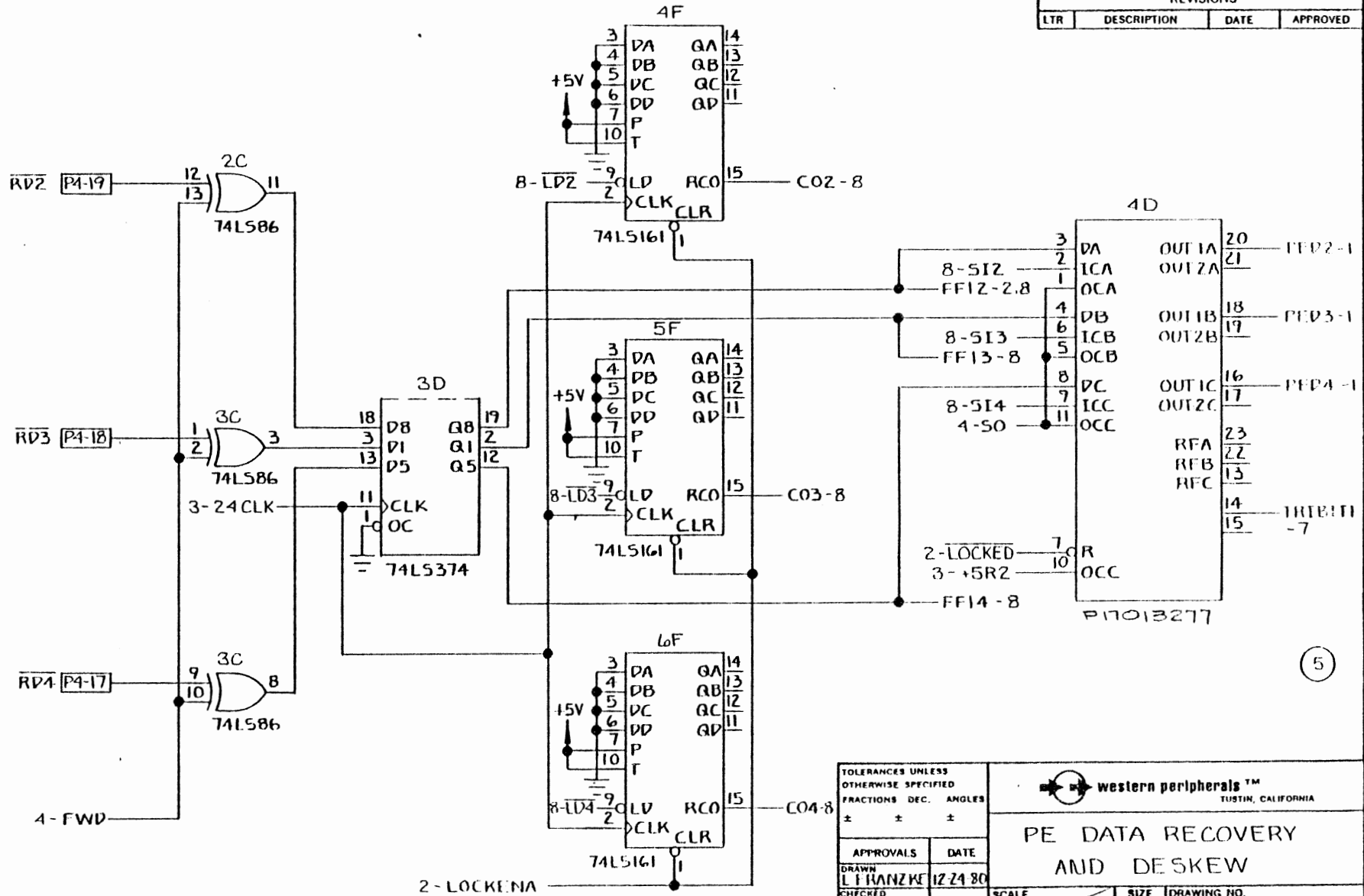

(5)

| | | | |
|---------------------------------------|----------|---|--|
| TOLERANCES UNLESS OTHERWISE SPECIFIED | | western peripherals™ TUSTIN, CALIFORNIA | |
| FRACTIONS | DEC. | | |
| ± | ± | ± | PE DATA RECOVERY AND DESKEW |
| APPROVALS | DATE | SCALE | |
| DRAWN L I HANZKE | 12-24-80 | SIZE B | |
| CHECKED HDKCXA | 12-24-80 | DRAWING NO. 75000786 | |
| DO NOT SCALE DRAWING | | | SHEET 6 OF 10 |

504110 A

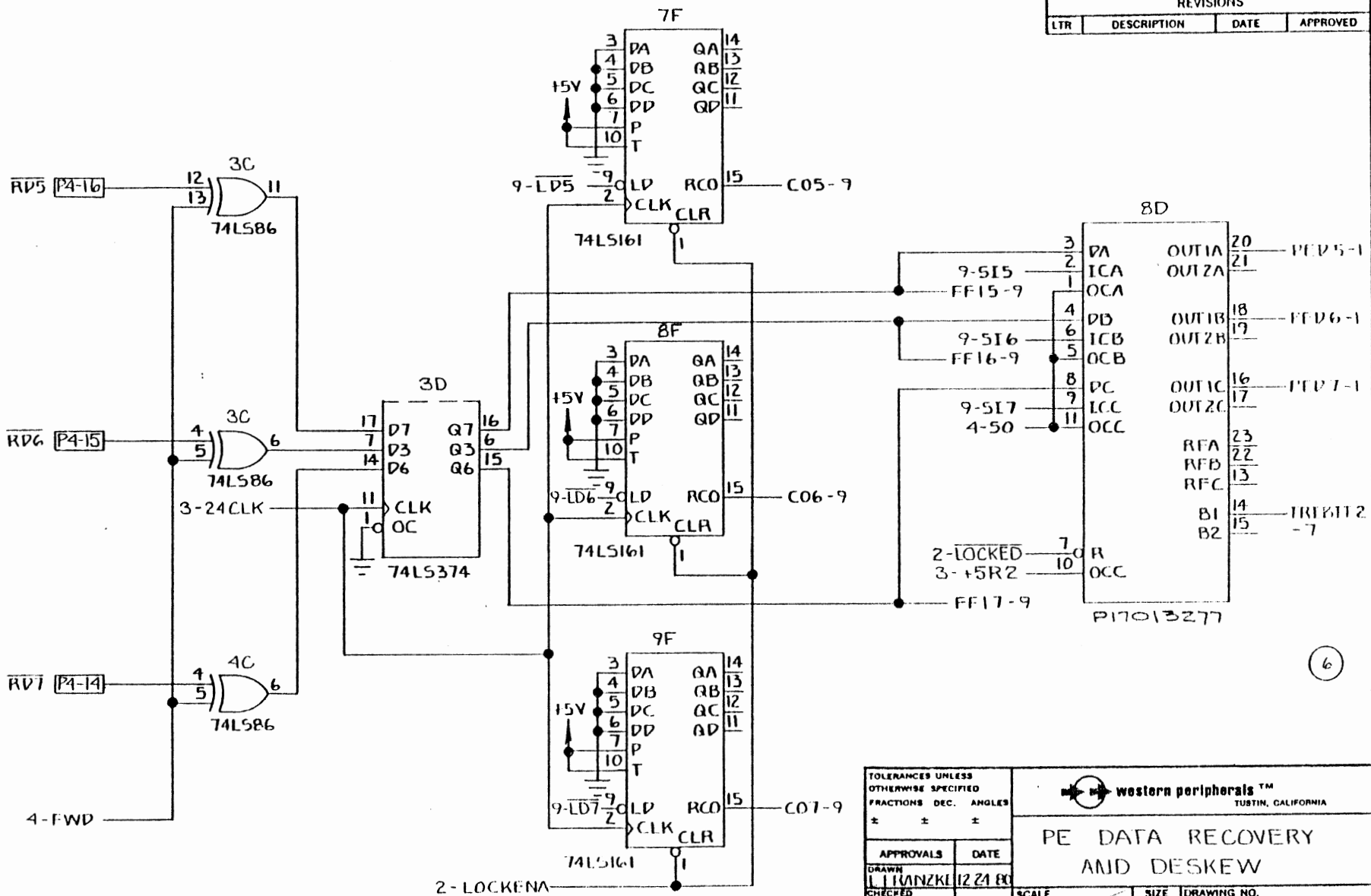

| REVISIONS | | | |
|-----------|-------------|------|----------|
| LTR | DESCRIPTION | DATE | APPROVED |

6

| | | | |
|---|----------|---|-------------------------|
| TOLERANCES UNLESS OTHERWISE SPECIFIED FRACTIONS DEC. ANGLES ± ± ± | | western peripherals™ TUSTIN, CALIFORNIA | |
| PE DATA RECOVERY AND DESKEW | | | |
| APPROVALS | DATE | SCALE | SIZE |
| DRAWN L. HANZKE | 12 21 80 | | B |
| CHECKED H. KOGA | 12 24 80 | | DRAWING NO. 75000786 |
| DO NOT SCALE DRAWING | | | SHEET 7 OF 10 |

| REVISIONS | | | |
|-----------|-------------|------|----------|
| LTR | DESCRIPTION | DATE | APPROVED |

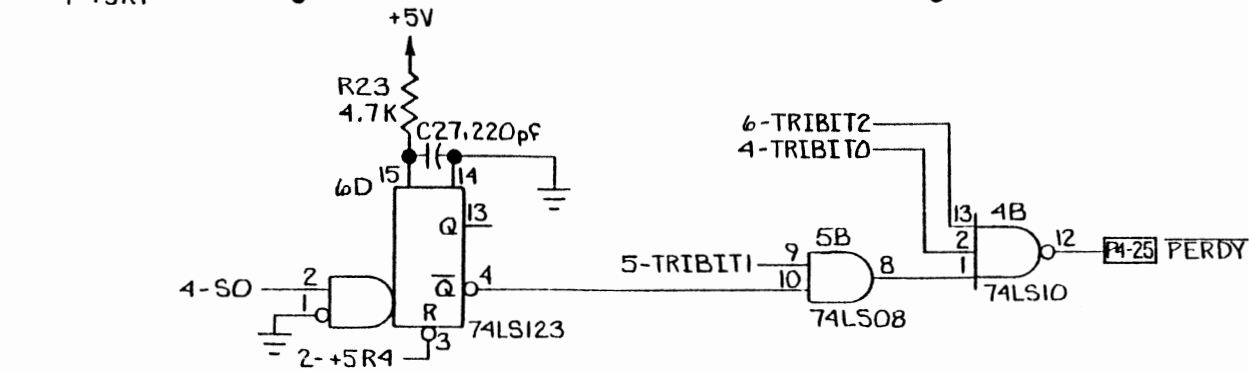
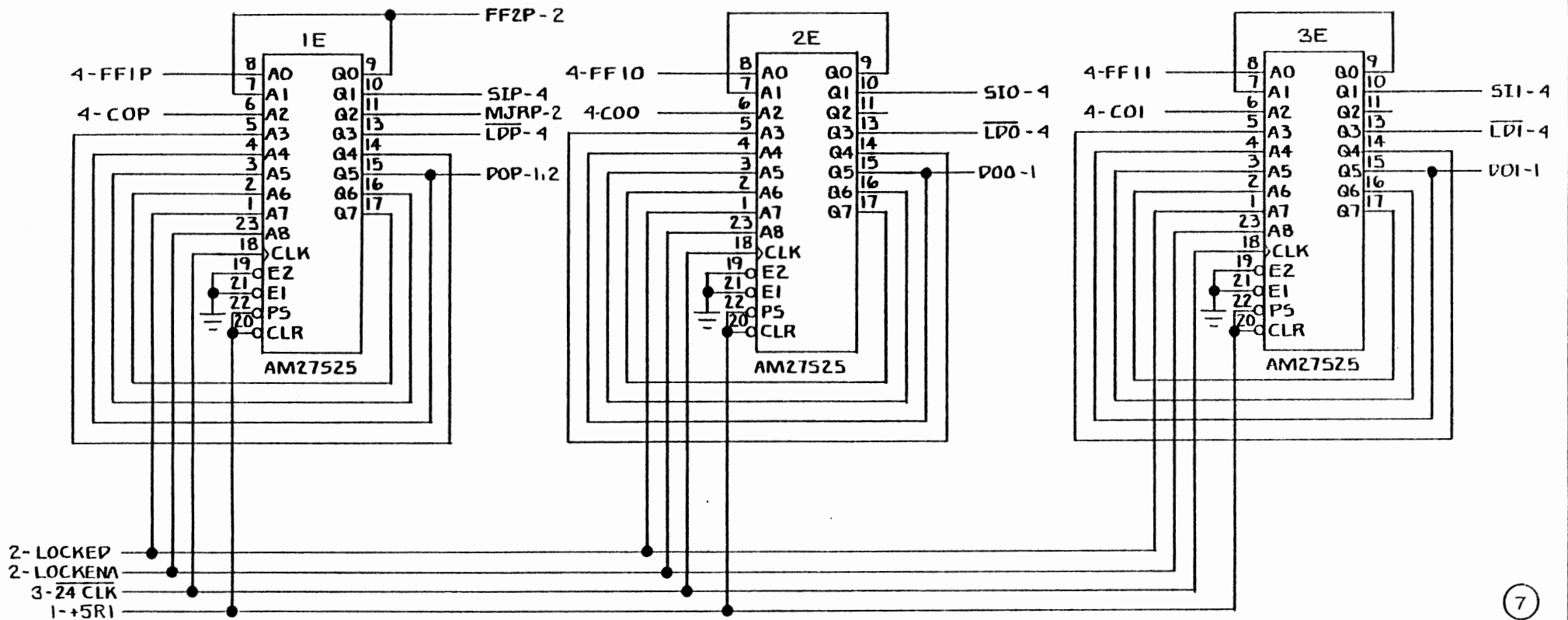

| | | | |
|---|--|--|-------------------------|
| TOLERANCES UNLESS OTHERWISE SPECIFIED FRACTIONS DEC. ANGLES ± ± ± | | western peripherals™ TUSTIN, CALIFORNIA | |
| APPROVALS | | DATE | |
| DRAWN L. F. HANZKI | | 12-21-80 | |
| CHECKED HDKOGA | | 11-26-80 | |
| SCALE | | SIZE B | DRAWING NO. 75000786 |
| DO NOT SCALE DRAWING | | | SHEET 8 OF 10 |

| REVISIONS | | | |
|-----------|-------------|------|----------|
| LTR | DESCRIPTION | DATE | APPROVED |
| | | | |

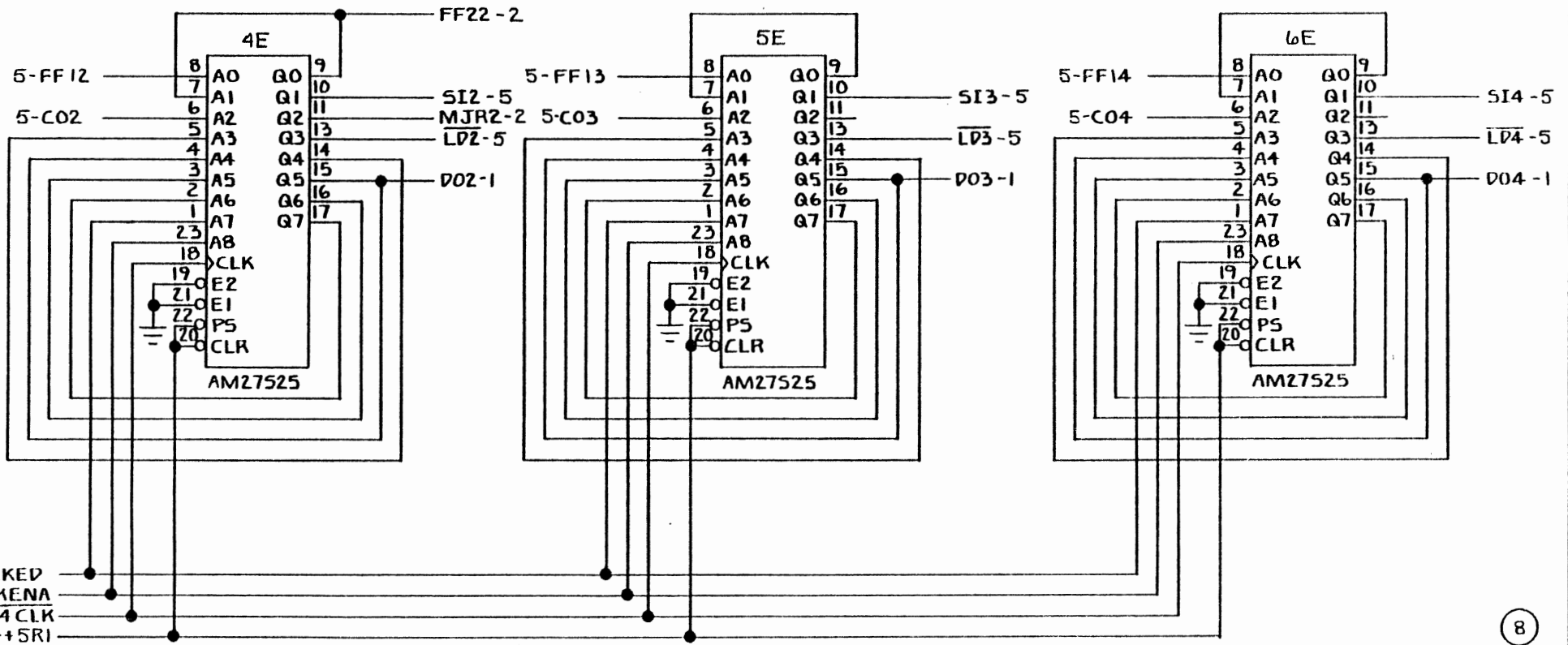

8

TOLERANCES UNLESS OTHERWISE SPECIFIED
FRACTIONS DEC. ANGLES
± ± ±



| | |
|---------------------|----------|
| APPROVALS | DATE |
| DRAWN L. FRANZKE | 12-24-80 |
| CHECKED H. KOGA | 12-24-80 |

PE CHNL SEQ CTRL

| | | |
|-------|------|-------------|
| SCALE | SIZE | DRAWING NO. |
| | B | 75000786 |

DO NOT SCALE DRAWING SHEET 9 OF 10

| REVISIONS | | | |
|-----------|-------------|------|----------|
| LTR | DESCRIPTION | DATE | APPROVED |
| | | | |

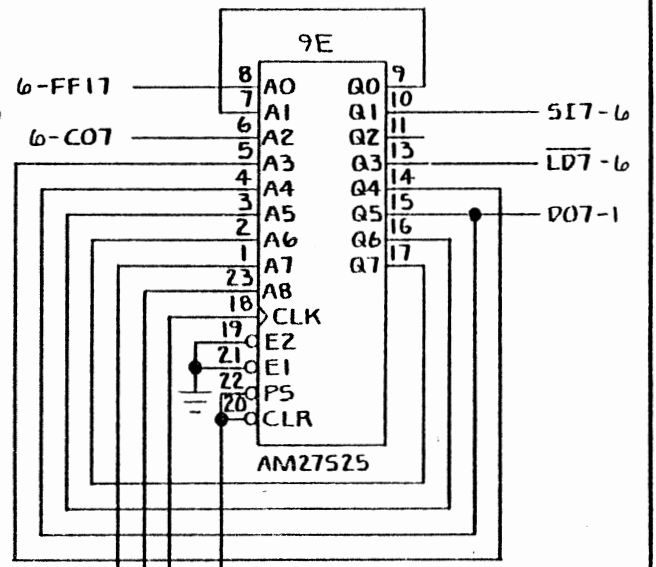
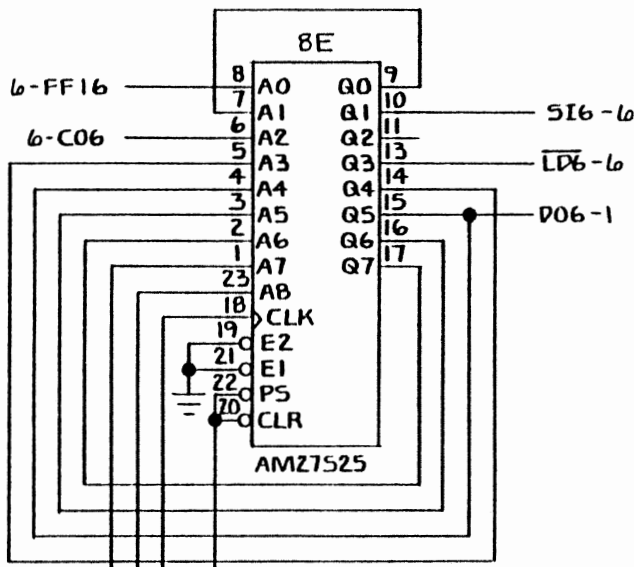
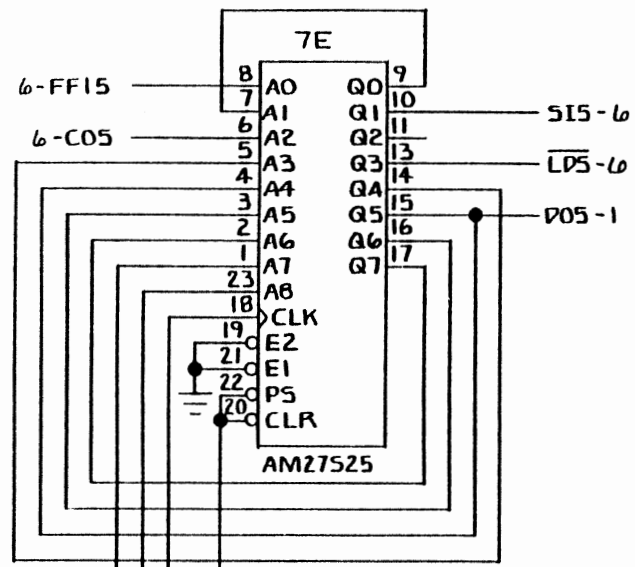

2- LOCKED
 2- LOCKENA
 3- 24 CLK
 1- +5RI

9

| | | | |
|--|----------|--|----------------|
| TOLERANCES UNLESS OTHERWISE SPECIFIED FRACTIONS DEC. ANGLES | | western peripherals™ TUSTIN, CALIFORNIA | |
| ± ± ± | | PE CHNL SEQ CTRL | |
| APPROVALS | DATE | SCALE | DRAWING NO. |
| DRAWN L. FRANZKI | 12-21-80 | B | 75000786 |
| CHECKED HD KOGA | 12-14-80 | DO NOT SCALE DRAWING | |
| | | | SHEET 10 OF 10 |

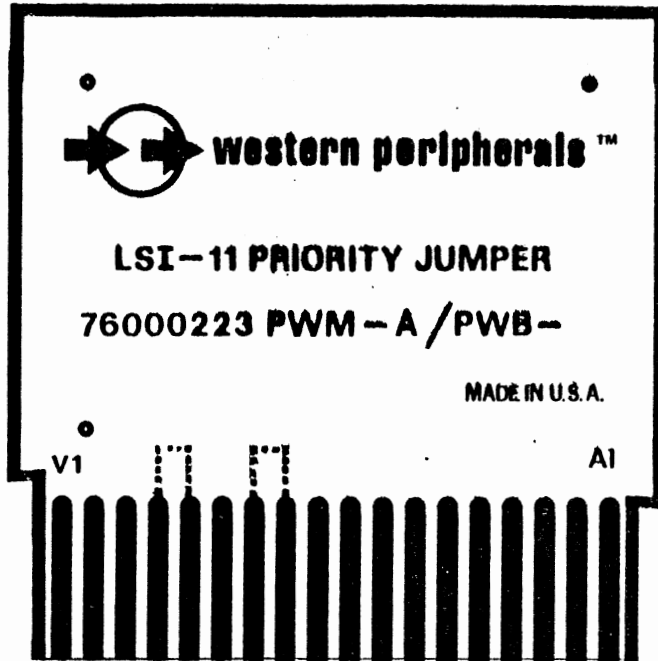

| | | | |
|---|--|--|--------------|
| TOLERANCES UNLESS OTHERWISE SPECIFIED FRACTIONS DEC. ANGLES ± ± ± | |  western peripherals ANAHEIM, CALIFORNIA | |
| APPROVALS | | DATE | |
| DRAWN <i>W. J. Davis</i> | | 5/21/77 | |
| CHECKED <i>J. J. Davis</i> | | 5/21/77 | |
| FAI/A Z | | 5/22/77 | |
| | | LSI-11 PRIORITY JUMPER | |
| SCALE | | SIZE | DRAWING NO. |
| 2:1 | | B | 76000223 |
| DO NOT SCALE DRAWING | | | SHEET 1 OF 3 |

03/15/82 BILL OF MATERIAL TOP LEVEL ASSEMBLY LIST
 ASSEMBLY NO. P18CC1511 REVISION D1

PAGE 1
 DESC: PRST PROM SET, TC151

| SEG | PART NUMBER | DESCRIPTION | CCN | QTY | HRS | SUB | REV | L | LOCATION | EFF DATE |
|-----|-------------|--------------------------|-----|-----|-----|-----|-----|---|----------|----------|
| CC0 | LSC | NO INVENTORY ITEM | | 14 | .0 | | | | | C1/14/81 |
| OC1 | P17019704 | PROM TC131 27G (27S19) | | 1 | .0 | S | | | 18G | C3/27/81 |
| OC2 | P17017518 | PROM TC151 1CB (27S25) | | 1 | .0 | S | B | | 10E | C3/12/82 |
| OC3 | P17017526 | PROM TC151 12B (27S25) | | 1 | .0 | S | B | | 12E | C3/12/82 |
| OC4 | P17017534 | PROM TC151 1CC-A (27S25) | | 1 | .0 | S | B | | 10C-A | C3/12/82 |
| OC5 | P17017542 | PROM TC151 1CC-B (27S25) | | 1 | .0 | S | B | | 1CC-B | C3/12/82 |
| OC6 | P17017559 | PROM TC151 12C-A (27S25) | | 1 | .0 | S | B | | 12C-A | C3/12/82 |
| OC7 | P17017567 | PROM TC151 12C-B (27S25) | | 1 | .0 | S | B | | 12C-B | C3/12/82 |
| CC8 | P17017575 | PROM TC151 1CD-A (27S25) | | 1 | .0 | S | B | | 10D-A | C3/12/82 |
| OC9 | P17017583 | PROM TC151 1CD-B (27S25) | | 1 | .0 | S | B | | 10C-B | C3/12/82 |
| O10 | P17017591 | PROM TC151 12D-A (27S25) | | 1 | .0 | S | B | | 12D-A | C3/12/82 |
| O11 | P17017609 | PROM TC151 12D-B (27S25) | | 1 | .0 | S | C | | 12D-B | C3/12/82 |
| O12 | P17017617 | PROM TC151 1CE (27S25) | | 1 | .0 | S | B | | 10E | C3/12/82 |
| O13 | P17017625 | PROM TC151 12E (27S25) | | 1 | .0 | S | B | | 12E | C3/12/82 |
| O14 | P17017633 | PROM TC151 3C (82S10C) | | 1 | .0 | S | A | | 3C | C3/12/82 |

MAR 17 1982

03/15/82 BILL OF MATERIAL TOP LEVEL ASSEMBLY LIST
ASSEMBLY NO. P18CG1321 REVISION B1

PAGE 1
DESC: PRST, TC131/151, PE

| SEQ | PART NUMBER | DESCRIPTION | CCN | QTY | HRS | SUB | REV | L | LOCATION | EFF DATE |
|-----|-------------|-------------------------------|-----|-----|-----|-----|-----|---|----------|----------|
| 000 | LSC | NO INVENTORY ITEM | | 2 | .0 | | | | | 03/05/81 |
| 001 | P1702C785 | PROM TC110/131/151 PE SEQUENC | | 9 | .0 | | A | | 1F-9F | 03/12/82 |
| 002 | P17019761 | PROM TC131 9D (27S25) | | 1 | .0 | S | | | 9D | 03/05/81 |

MAR 17 1982

| REVISIONS | | | |
|-----------|-----------------|---------|------------|
| LTR | DESCRIPTION | DATE | APPROVED |
| A | INITIAL RELEASE | 3-24-81 | <i>llk</i> |
| B | Update ECO 969 | 9-25-81 | <i>llk</i> |

PURPOSE

This modification provides capability to control 12.5 and 18.75 ips drives.

1. Rework TC151 Assy 60000619 or 60000866 as follows:
 - a. Replace PROM in Location 18G with PROM P17017492.
 - b. Set switches 1, 2 and 4 OFF (OPEN).
 - c. Set switch 3 ON (CLOSED).
2. Rework TC151 PE Adapter Assy 60000627 or 60000874 as follows:
 - a. Cut etch on solder side at 3B-14.
 - b. Jumper 3B-1 to 3B-14.
 - c. Add 100 pf capacitor in parallel to existing capacitor C13.
 - d. Add 390 pf capacitor in parallel to existing capacitor C15.
3. Identify both assemblies by marking "CONF A" on them using contrasting ink.
4. For 12.5 ips drives, switch 4 on the tape control adapter at the drive end of the control cable must be OPEN. CLOSE it for 18.75 ips drives.
5. Material required:
 - a. PROM P/N P17017492
 - b. 100 pf capacitor (W.P. P/N P15000136 or equivalent)
 - c. 390 pf capacitor (W.P. P/N P15000243 or equivalent)
6. The resultant changes to TC151 PE Adapter schematic Sht ③ are shown on Sht 2 of this drawing.

NOTE: FOR NRZ ONLY UNIT (TC151N), SEE MOD DWG 79000717

AUG 26 1981

| | | | |
|---------------------------------------|------|--|---|
| TOLERANCES UNLESS OTHERWISE SPECIFIED | |  western peripherals™ TUSTIN, CALIFORNIA | |
| FRACTIONS | DEC. | | |
| ± | ± | ± | Modification Drawing - TC151 Configuration "A" |
| APPROVALS | | DATE | |
| DRAWN <i>H. Deutsch</i> | | 3-24-81 | |
| CHECKED <i>llk</i> | | 3-24-81 | SCALE |
| | | | SIZE A |
| | | | DRAWING NO. 79000691 |
| DO NOT SCALE DRAWING | | | SHEET 1 OF 2 |

| REVISIONS | | | |
|-----------|-------------|------|----------|
| LTR | DESCRIPTION | DATE | APPROVED |
| | | | |

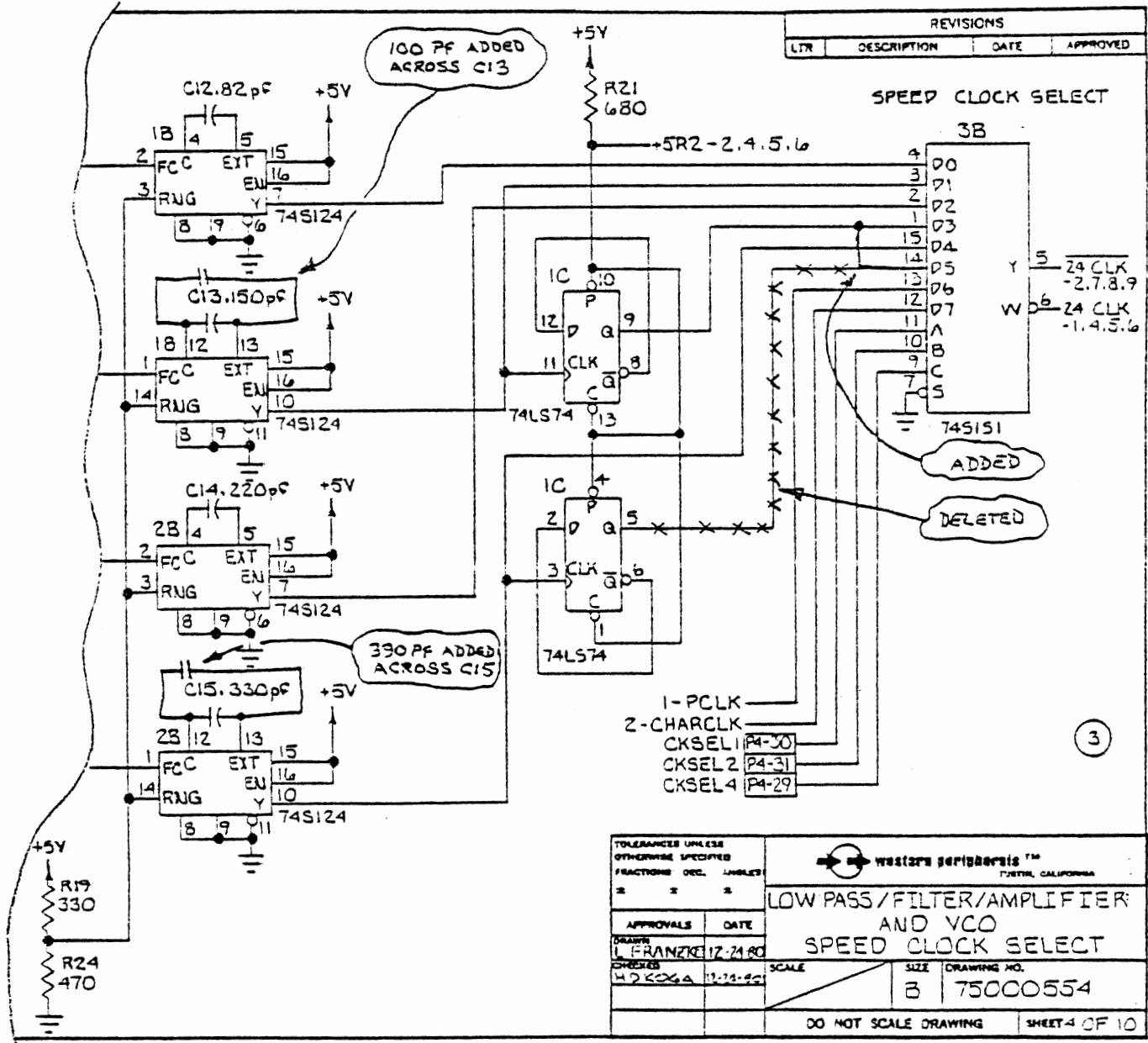

| REVISIONS | | | |
|-----------|-------------|------|----------|
| LTR | DESCRIPTION | DATE | APPROVED |
| | | | |

| | | | |
|---|----------|--|---------------|
| TOLERANCES UNLESS OTHERWISE SPECIFIED FRACTIONS DEC. UNLESS | | WESTERN PERIPHERALS™ FURNISH, CALIFORNIA | |
| APPROVALS | DATE | LOW PASS / FILTER / AMPLIFIER AND VCO SPEED CLOCK SELECT | |
| DESIGNED BY L. FRANZKE | 12-21-80 | SCALE | SIZE B |
| CHECKED BY H. D. KOGA | 12-21-80 | DRAWING NO. 75000554 | |
| DO NOT SCALE DRAWING | | | SHEET 4 OF 10 |

AUG 26 1981

| | | |
|----------------------|------------------|-------------------------|
| SCALE | SIZE A | DRAWING NO. 79000691 |
| DO NOT SCALE DRAWING | | SHEET 2 OF 2 |

REVISIONS

| LTR | DESCRIPTION | DATE | APPROVED |
|-----|-----------------|---------|------------|
| A | INITIAL RELEASE | 3-25-81 | <i>LLT</i> |
| B | Update ECO 969 | 9-25-81 | |

PURPOSE

This modification provides capability to control 12.5 and 18.75 ips drives.

1. Rework TC151 Assy 60000619 or 60000866 as follows:
 - a. Replace PROM in location 18G with PROM P17017492.
 - b. Set switches 1, 2 and 4 OFF (OPEN).
 - c. Set switch 3 ON (CLOSED).
 - d. Identify the assembly by marking "CONF A" on it using contrasting ink.
2. For 12.5 ips drives, switch 4 on the tape control adapter at the drive end of the control cable must be OPEN. CLOSE it for 18.75 ips drives.
3. Material required:
 - a. PROM P17017492

NOTE: FOR PHASE ENCODED UNIT, SEE MOD DWG 79000691

AUG 26 1981

| | | | | | |
|---|--|--|---|------------------|-------------------------|
| TOLERANCES UNLESS OTHERWISE SPECIFIED FRACTIONS DEC. ANGLES ± ± ± | | |  western peripherals ™ TUSTIN, CALIFORNIA | | |
| APPROVALS DATE DRAWN L. CRAWFORD 3-25-81 | | | Modification Drawing - TC151N Configuration "A" | | |
| CHECKED <i>J. Deutch</i> 3-25-81 | | | | | |
| | | | SCALE | SIZE A | DRAWING NO. 79000717 |
| | | | DO NOT SCALE DRAWING | | SHEET 1 OF 1 |

| REVISIONS | | | |
|-----------|-------------|------|----------|
| LTR | DESCRIPTION | DATE | APPROVED |

| | | | |
|---|----------|----------|-----------|
| A | PROD REL | 10-28-81 | <i>MJ</i> |
|---|----------|----------|-----------|

REF ASSY: 60000619

OCT 29 1981

| | | | |
|---------------------------------------|------|---|--------------|
| TOLERANCES UNLESS OTHERWISE SPECIFIED | |  western peripherals ™ TUSTIN, CALIFORNIA | |
| FRACTIONS | DEC. | | |
| ± | ± | ± | |
| APPROVALS | | DATE | |
| <i>KM</i> | | 10-26-81 | |
| CHECKED | | SCALE | SIZE |
| | | — | A |
| | | DRAWING NO. | |
| | | P790000931 | |
| DO NOT SCALE DRAWING | | | SHEET 1 OF 4 |

CONFIG C
TC151 IBM PACK SW.

| REVISIONS | | | |
|-----------|-------------|------|----------|
| LTR | DESCRIPTION | DATE | APPROVED |

TC-151

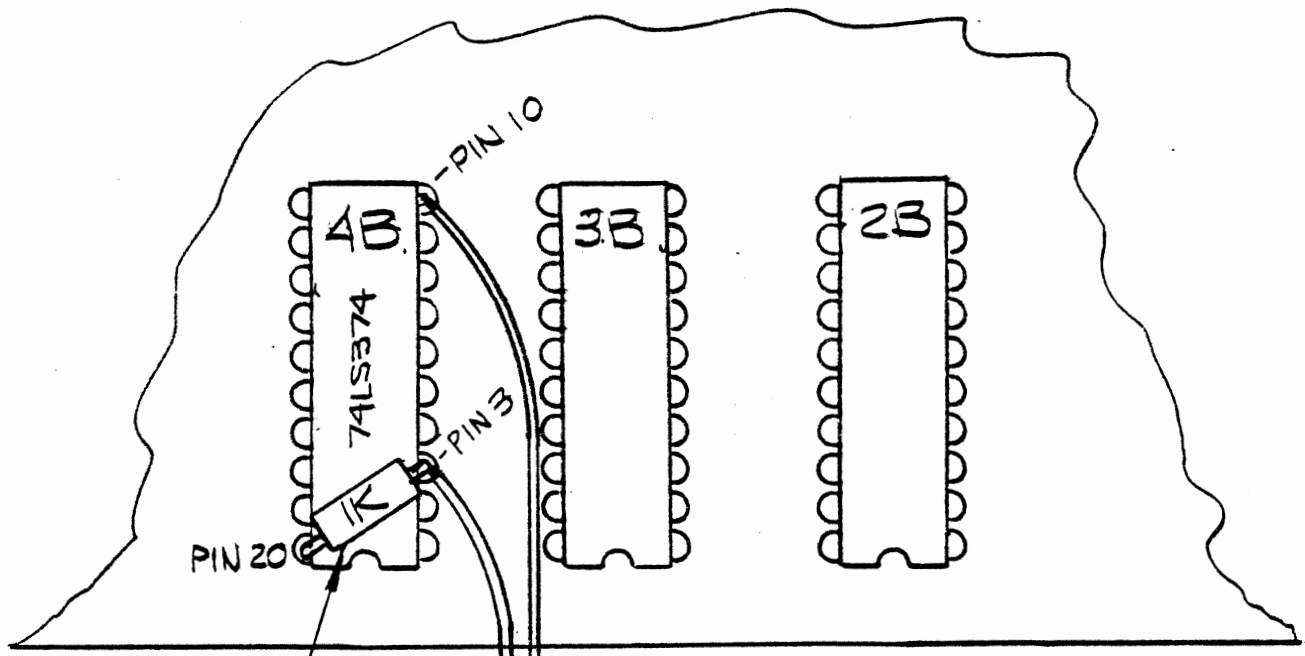

1K, 1/4W, 5% RESISTOR

30 AWG WIRE

FRONT

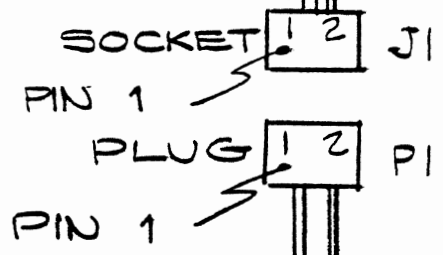

SEE NEXT SHEET FOR INSTRUCTIONS

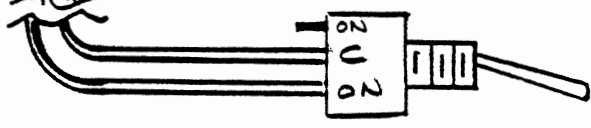

SW 1

OCT 29 1981

| | | |
|----------------------|------------------|--------------------------|
| SCALE <i>7</i> | SIZE A | DRAWING NO. P79000931 |
| DO NOT SCALE DRAWING | | SHEET 2 OF 4 |

TC 151

| REVISIONS | | | |
|-----------|-------------|------|----------|
| LTR | DESCRIPTION | DATE | APPROVED |

INSTALLATION INSTRUCTIONS

1. INSTALL 1K. 1/4W. 5% RESISTOR BETWEEN PINS 4B-3 TO 4B-20 AS SHOWN ON SHT. 2.
2. ADD WIRE FROM SOCKET J1-1 TO 4B PIN 3 AS SHOWN ON SHT 2
3. ADD WIRE FROM SOCKET J1-2 TO 4B PIN 10 AS SHOWN ON SHT 2.
4. ADD SWITCH TO FRONT PANEL AS SHOWN ON SHT 1
5. CONNECT SOCKET J1 TO PLUG PI

SCHEMATIC

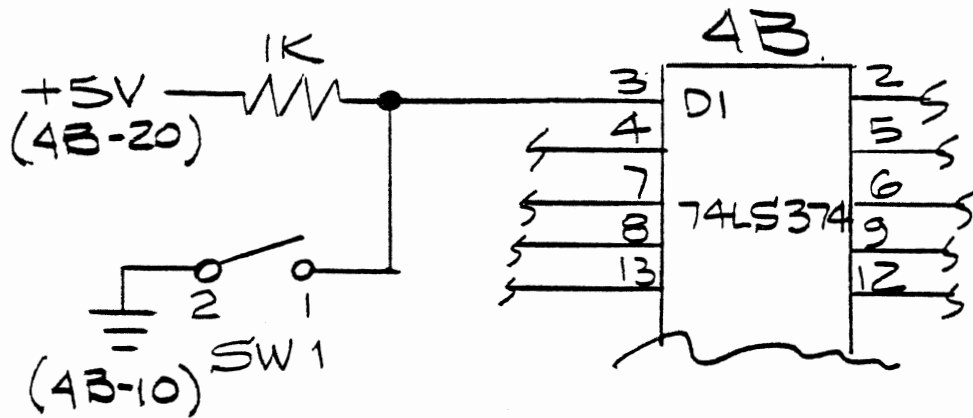

SW-1 = ON POS = IBM
OFF POS = DEC

OCT 29 1981

| | | |
|----------------------|------------------|--------------------------|
| SCALE <i>2</i> | SIZE A | DRAWING NO. P79000931 |
| DO NOT SCALE DRAWING | | SHEET 3 OF 4 |

| | | | |
|---------------------------|-------------------------|------------|------|
| DRAWN BY <i>HARRIS</i> | DATE <i>10-28-81</i> | CHECKED BY | DATE |
|---------------------------|-------------------------|------------|------|

BILL OF MATER LS



| | |
|------------------------------|-----|
| DWG. NO. <i>P79000931</i> | REV |
|------------------------------|-----|

SHEET *4* OF *4*

TITLE *TC 151*
CONFIGURATION "C"

| ITEM | QUAN | UNITS | PART NUMBER | DESCRIPTION |
|----------|------------|-------|------------------|--|
| <i>1</i> | <i>1</i> | | <i>P23004179</i> | <i>PLUG, 3M, 03-06-1023</i> |
| <i>2</i> | <i>1</i> | | <i>P23004153</i> | <i>SKT, 3M, 03-06-2023</i> |
| <i>3</i> | <i>2</i> | | <i>P23004633</i> | <i>CONTACT MALE, 3M, 02-06-2132</i> |
| <i>4</i> | <i>2</i> | | <i>P23004617</i> | <i>CONTACT, FEMALE, 3M, 02-06-1132</i> |
| <i>5</i> | <i>1</i> | | <i>W20000097</i> | <i>SWITCH</i> |
| <i>6</i> | <i>1FT</i> | | <i>P28001410</i> | <i>WIRE - 30 AWG, BK</i> |
| | | | | |
| | | | | |
| | | | | |
| | | | | |
| | | | | |
| | | | | |
| | | | | |
| | | | | |
| | | | | |
| | | | | |
| | | | | |
| | | | | |
| | | | | |
| | | | | |
| | | | | |
| | | | | |
| | | | | |
| | | | | |
| | | | | |
| | | | | |
| | | | | |
| | | | | |
| | | | | |
| | | | | |

"S" FOR SUB-ASSY
REF.DESIG.

1981
OCT 29 1030

REWORK INSTRUCTIONS

| REVISIONS | | | |
|-----------|-------------|---------|--------------------|
| LTR | DESCRIPTION | DATE | APPROVED |
| A | PROD. REL | 4-21-82 | <i>[Signature]</i> |

THIS CONFIGURATION ALLOWS THE FUNCTION OF REMOTE DENSITY SELECT WITH BIT 10 OF MTC REGISTER ON TC 151 NRZ.

ASSY. AFFECTED: 60000866

REWORK INSTRUCTIONS:

- LIFT PINS AT 19A-5 AND 15A-3.
- ADD WIRES IN THE FOLLOWING LOCATIONS:

| <u>FROM</u> | <u>TO</u> |
|-------------|-----------|
| 2B-15 | 18A-17 |
| 15A-3 | 15A-4 |

REWORK INSTRUCTIONS FOR SCHEMATIC # 75000778:

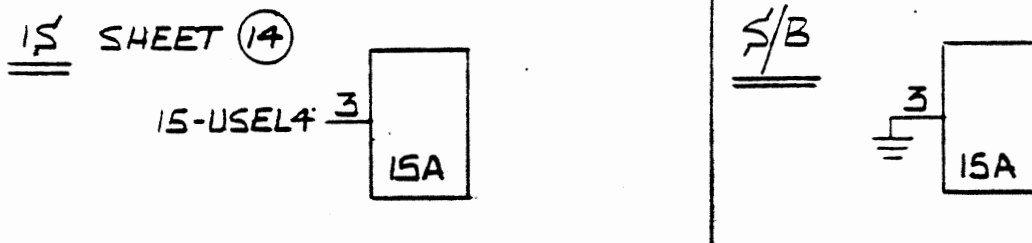
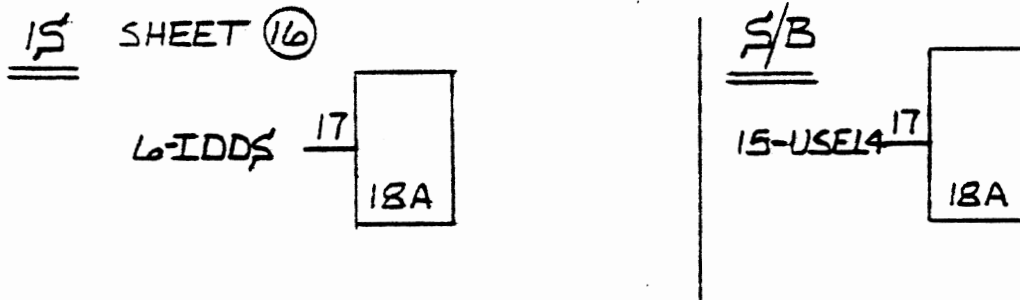
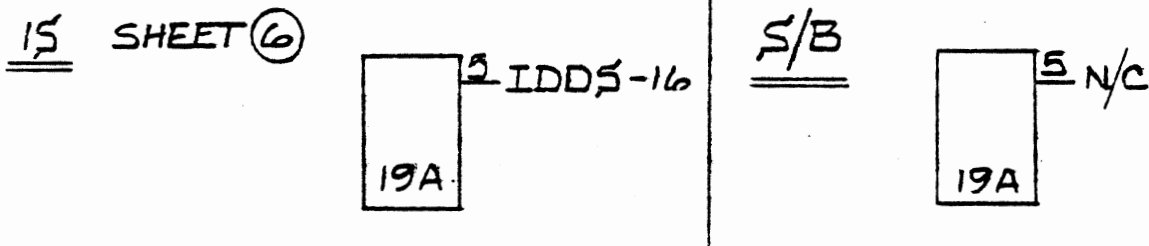

APP 2 2 1982

| | | | |
|--|--|--|----------------------------------|
| TOLERANCES UNLESS OTHERWISE SPECIFIED FRACTIONS: DEC. ANGLES ± ± ± | | western peripherals™ TUSTIN, CALIFORNIA | |
| APPROVALS DRAWN: SIMBECK CHECKED: <i>[Signature]</i> | | CONFIGURATION "D" TC 151 NRZ | |
| DATE: 4-21-82 DATE: 4-22-82 | | SCALE: <i>[Signature]</i> | SIZE: A DRAWING NO.: 79001194 |
| DO NOT SCALE DRAWING | | | SHEET 1 OF 1 |

NOTES

| MAIN CONTROLLER BOARD | | | | |
|-----------------------|--|-----------|-------------|-----------|
| | CONNECTOR A | | CONNECTOR B | |
| | 1 | 2 | 1 | 2 |
| A | BIRQ5L-4 | *5V-Ø | BDCOKH-2 | *5V-Ø |
| B | BIRQ6L-4 | | | |
| C | BDAL16L-3 | *GND-Ø | | *GND-Ø |
| D | BDAL17L-3 | | BE2 | |
| E |  SCHEMATIC PAGE NUMBER | BDOUTL-3 | SCHEMATIC | BDAL02L-1 |
| F | | BRPLYL-3 | CONNECTOR | BDAL03L-1 |
| H | | BDINL-3 | SYMBOL | BDAL04L-1 |
| J | | BSYNCL-3 | | BDAL05L-1 |
| K | | BWTBTL-3 | | BDAL06L-1 |
| L | BIRQ4L-4 | | | BDAL07L-1 |
| M | | BIAKIL-2 | | BDAL08L-1 |
| N | BDMRL-4 | BIAKOL-4 | BSACKL-4 | BDAL09L-1 |
| P | | BBS7L-3 | BIRQ7L-4 | BDAL10L-1 |
| R | | BDMGIL-2 | | BDAL11L-1 |
| S | | BDMGOL-4 | | BDAL12L-1 |
| T | *GND-Ø | BINITL-2 | *GND-Ø | BDAL13L-1 |
| U | | BDAL00L-1 | | BDAL14L-1 |
| V | | BDAL01L-1 | | BDAL15L-1 |

TC-151 BUS CONNECTIONS

1 = COMPONENT SIDE 2 = SOLDER SIDE

* ONLY INDICATED POWER & GND CONNECTIONS ARE MADE
TO CONNECTORS C, D, AND PE ADAPTER CONNECTORS A & B.

** THESE SIGNALS ARE JUMPERED ON CONNECTOR C & PE ADAPTER CONNECTOR A

4

APPENDIX A

STANDARD TAPE DRIVE
CABLES AND ADAPTERS

12-16-81

TABLE OF CONTENTS

| TITLE | DRAWING NO. |
|---|-----------------|
| Modification Drawing, Tape Control Adapter (Config. "S") | 112001 |
| Assembly - Cable, Control | 121004 |
| Assembly - Cable, Read | 121006 |
| Assembly - Cable, Write | 121014 |
| Assembly Drawing - Adapter, Tape Read Connector | 122005 |
| Assembly Drawing - Tape Write Connector | 122006 |
| Assembly, Jumper Array, Select Switch Option | 122010 |
| Assembly, Jumper Array, Select Switch Option, Special | 122011 |
| Assembly, Jumper Array, Non-Select Switch Option | 122012 |
| Assembly Drawing - Adapter, Tape Read, Kennedy, Cipher | 122018 |
| Assembly Drawing - Adapter, Tape Write, Kennedy, Cipher | 122019 |
| Schematic - Adapter, Tape Write Connector | 122021 |
| Schematic - Adapter, Tape Read Connector | 122022 |
| Assembly, Adapter, Tape Write, Kennedy 9800 | 122034 |
| Assembly, Adapter, Tape Read, Kennedy 9800 | 122035 |
| Schematic - Tape Control Adapter | 122036 |
| Assembly - Adapter, Tape Control Connector | 122037 |
| Assembly - Adapter, Tape Control Connector, 90° Mounting | 122038 |
| Assembly - Adapter, Tape Control Connector, 2-inch Standoff | 122039 |
| Assembly - Adapter, Tape Read, Reverse Image, 90° | 122043 |
| Modification Drawing, Tape Control Adapter (Config. "N") | 122044 |
| Modification Drawing, Cipher 900X (Config. "A") | 79000410 |
| Modification Drawing, Cipher 900X (Config. "B") | 79000642 |
| Notes | |

FUNCTIONAL INDEX

| | | DRAWING NO. |
|------|---|-----------------|
| I. | RIBBON CABLES AND BACKPLANE CONNECTORS | |
| | Assembly - Cable, Control | 121004 |
| | Assembly - Cable, Read | 121006 |
| | Assembly - Cable, Write | 121014 |
| II. | ADAPTER PADDLEBOARDS | |
| I. | SCHEMATICS | |
| | Schematic - Tape Control Adapter | 122036 |
| | Schematic - Adapter, Tape Write Connector | 122021 |
| | Schematic - Adapter, Tape Read Connector | 122022 |
| 2. | ASSEMBLY DRAWINGS | |
| | a. CONTROL | |
| | Assembly - Adapter, Tape Control Connector (Standard) | 122037 |
| | Assembly - Adapter, Tape Control Connector (90° Mount) | 122038 |
| | Assembly - Adapter, Tape Control Connector (2-inch Standoff) | 122039 |
| | b. WRITE | |
| | Assembly Drawing - Tape Write Connector (Standard) | 122006 |
| | Assembly Drawing - Adapter, Tape Writer (Reverse Image) | 122019 |
| | Assembly - Adapter, Tape Write (90° Mount) | 122034 |
| | c. READ | |
| | Assembly Drawing - Adapter, Tape Read Connector | 122005 |
| | Assembly Drawing - Adapter, Tape Read (Reverse Image) | 122018 |
| | Assembly - Adapter, Tape Read (90° Mount) | 122035 |
| | Assembly - Adapter, Tape Read (Reverse Image 90° Mount) | 122043 |
| | d. DRIVE SELECT JUMPERS | |
| | Assembly, Jumper Array, Select Switch Option | 122010 |
| | Assembly, Jumper Array, Select Switch Option (4th Drive) | 122011 |
| | Assembly, Jumper Array, Non-Select Switch Option | 122012 |
| III. | SPECIAL FEATURE MODIFICATIONS | |
| | Modification Drawing, Tape Control Adapter Configuration "S" | 112001 |
| | Modification Drawing - Tape Control Adapter Configuration "N" | 122044 |
| | Modification Drawing, Cipher 900X (Config. "A") | 79000410 |
| | Modification Drawing, Cipher 900X (Config. "B") | 79000642 |

PURPOSE:

THIS MODIFICATION REQUIRED FOR CONTROL OF QUANTEX TAPE DRIVES.

| REVISIONS | | | |
|-----------|--|---------|------------|
| LTR | DESCRIPTION | DATE | APPROVAL |
| A | REDRAWN TO CORRECT DETAIL FOR E OR F ARTWORK (REF ECQ 780) | 10-2-80 | <i>Kip</i> |

SHEET (2) OF SCHEMATIC 122036 IS ALTERED AS OUTLINED BELOW.

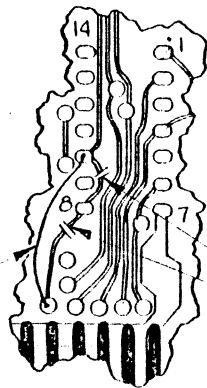
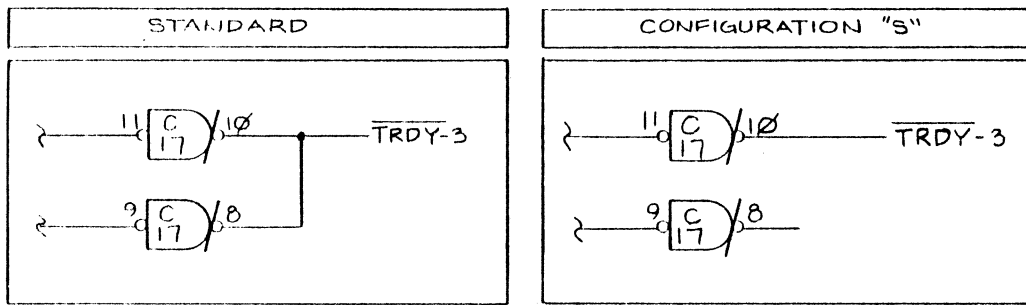

JUMPER

REWORK INSTRUCTIONS:

FOR ASSY: 122037, 122038, 122039

- A) CUT ETCH 2 PLCS AT C-8 (SOLDER SIDE)
- B) ADD JUMPER FROM C-10 TO FEED-THRU ON ETCH THAT WAS CONNECTED TO C-8
- C) IDENTIFY AT ASSY NO. WITH "CONF 5" USING BLACK INK.

CUT

SOLDER SIDE VIEW
IC. LOCATION "C"

OCT 2 1980

| | | | |
|--|---------|--|---|
| TOLERANCES UNLESS OTHERWISE SPECIFIED | | western peripherals™ TUSTIN, CALIFORNIA | |
| FRACTIONS | DEC | | |
| ± | ± | ± | MODIFICATION DWG- TAPE CONT. ADAPTER, CONF "S" |
| APPROVALS | DATE | SCALE | |
| DRAWN <i>AS</i> CHECKED <i>W. K. Kich</i> | 10-1-80 | 10-2-80 | |
| DO NOT SCALE DRAWING | | SIZE B | |
| | | DRAWING NO. 112001 | SHEET 1 OF 1 |

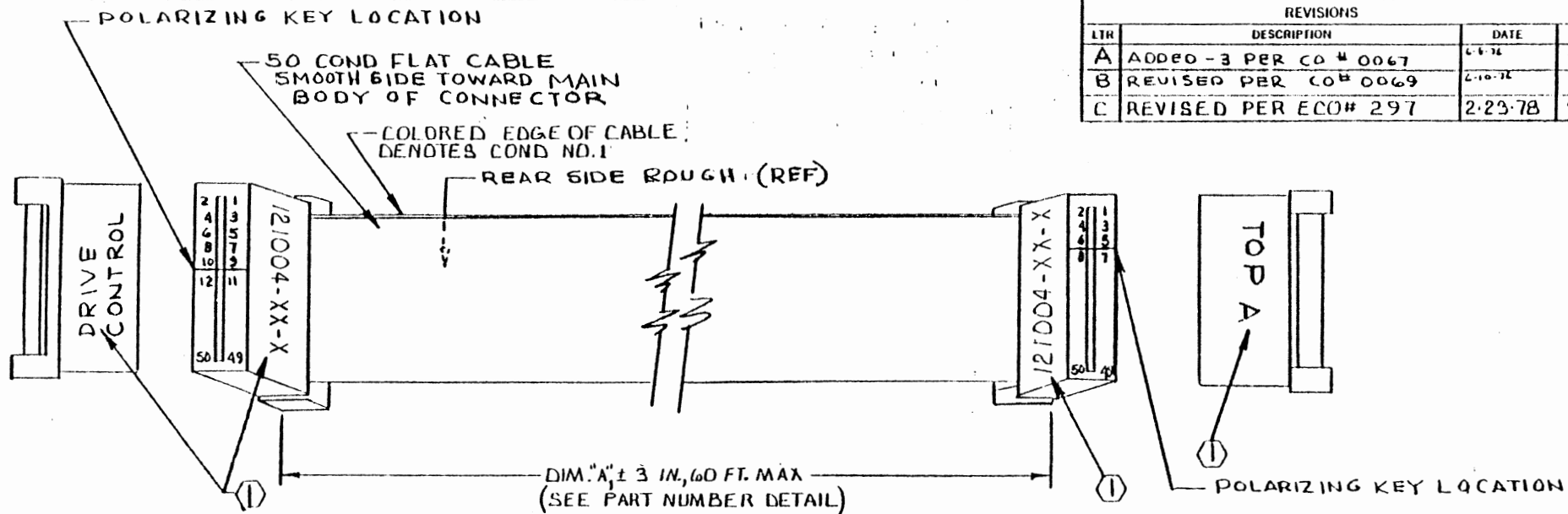

| REVISIONS | | | |
|-----------|------------------------|---------|------------|
| LTR | DESCRIPTION | DATE | APPROVED |
| A | ADDED -3 PER CO # 0067 | 6-1-76 | W.D. |
| B | REVISED PER CO# 0069 | 2-10-76 | W.D. |
| C | REVISED PER ECO# 297 | 2-23-78 | W.D., q-78 |

PART NUMBER DETAIL

| | |
|-------------------------------------|-------|
| 121004-XX-X | |
| BASIC PART NUMBER | _____ |
| DASH NUMBER IN FEET (REF. DIM. 'A') | _____ |
| (-07 FOR 7 FT, -10 FOR 10 FT, ETC.) | |
| LATEST REVISION LETTER | _____ |

NOTES.

① MARK CHARACTERS SHOWN USING CONTRASTING COLOR INK.
SEE PART NUMBER DETAIL FOR MARKING OF VARIABLE CHARACTERS (X's).

2. ASSEMBLY:

- USE 3M PRESS NO. 3440
- USE LOCATOR PLATE NO. 3443-II
- USE SETTING NO 9 OF GAUGE 3436-1
- CUT CABLE USING SCOTCHFLEX CABLE SHEAR OR EQUIV.
- SEAT CABLE INTO COVER USING SCOTCHFLEX TOOL NO. 3453, CHECK FOR ALIGNMENT
- PLACE BODY ON LOCATOR PLATE
- POSITION COVER AND CABLE OVER CONN BODY
- LOWER HANDLE TO COMPLETE ASSY
- REMOVE BY LIFTING ON CONNECTOR

FOR PARTS SEE PARTS LIST 121004

| | | | |
|---------------------------------------|-------------|--|--------|
| TOLERANCES UNLESS OTHERWISE SPECIFIED | | western peripherals ANAHEIM, CALIFORNIA | |
| FRACTIONS | DEC. | | |
| L | ± | ± | |
| APPROVALS | DATE | ASSEMBLY- CABLE, CONTROL | |
| DRAWN | 6-1-76 | | |
| CHECKED | W.D. 6-1-76 | | |
| SCALE | NONE | SIZE | B |
| | | DRAWING NO. | 121004 |
| DO NOT SCALE DRAWING | | | SHEET |

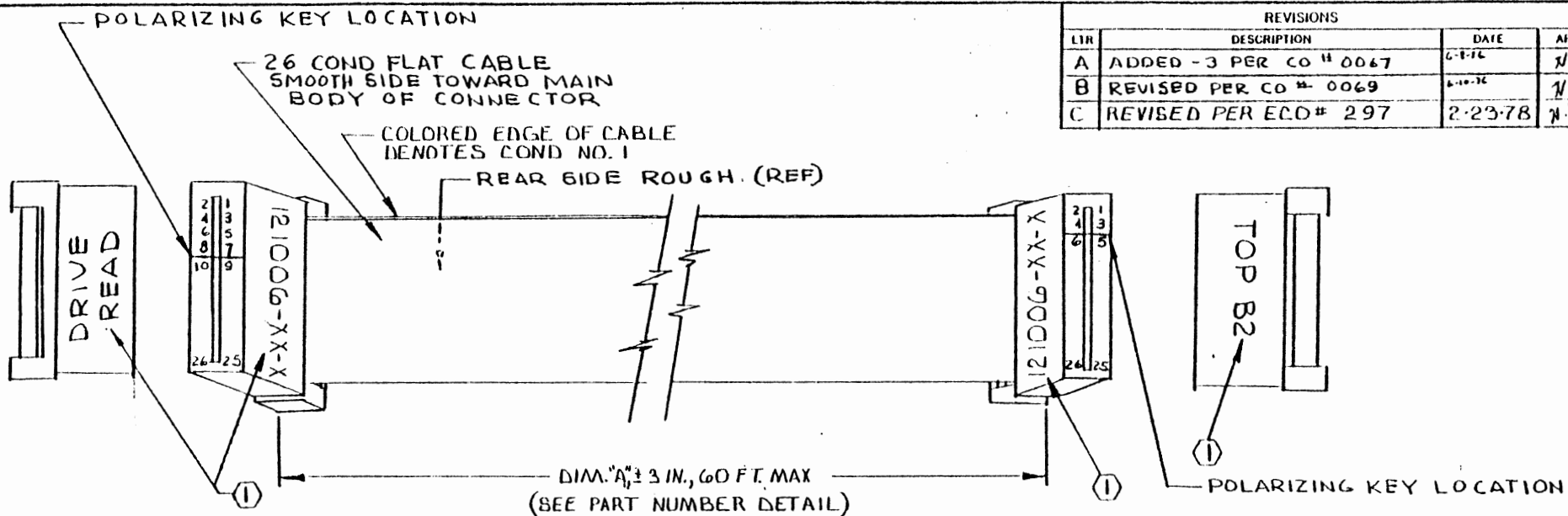

| REVISIONS | | | |
|-----------|------------------------|---------|-----------|
| LTR | DESCRIPTION | DATE | APPROVED |
| A | ADDED -3 PER CO # 0067 | 6-8-76 | N.D. |
| B | REVISED PER CO # 0069 | 6-10-76 | N.D. |
| C | REVISED PER ECD# 297 | 2-23-78 | N.D. 2-78 |

PART NUMBER DETAIL

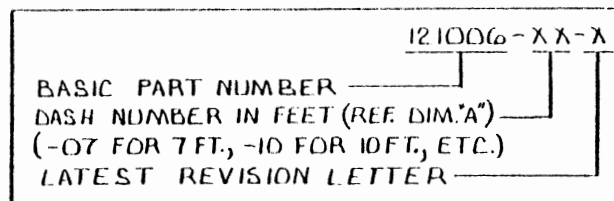

NOTES:

① MARK CHARACTERS SHOWN USING CONTRASTING COLOR INK.
SEE PART NUMBER DETAIL FOR MARKING OF VARIABLE CHARACTERS (X's).

2. ASSEMBLY:

- USE 3M PRESS NO 3440
- USE LOCATOR PLATE NO. 3443-II
- USE SETTING NO. 9 OF GAUGE NO. 3436-I
- CUT CABLE USING SCOTCHFLEX CABLE SHEAR OR EQUIV.
- BEAT CABLE INTO COVER USING SCOTCHFLEX TOOL NO 3453, CHECK FOR ALIGNMENT
- PLACE BODY ON LOCATOR PLATE
- POSITION COVER AND CABLE OVER CONN BODY
- LOWER HANDLE TO COMPLETE ASSY
- REMOVE BY LIFTING ON CONNECTOR

FOR PARTS SEE PARTS LIST 121006

| | | | |
|---------------------------------------|--------|---|---------------------------------|
| TOLERANCES UNLESS OTHERWISE SPECIFIED | | western peripherals ANAHEIM, CALIFORNIA | |
| FRACTIONS | DEC. | | |
| ± | ± | ± | ASSEMBLY CABLE, READ |
| APPROVALS | DATE | SCALE | |
| DRAWN FORUM | 6-1-76 | NONE | |
| CHECKED J.D. | 6-1-76 | SIZE B | |
| DO NOT SCALE DRAWING | | | DRAWING NO. 121006 |
| | | | SHEET |

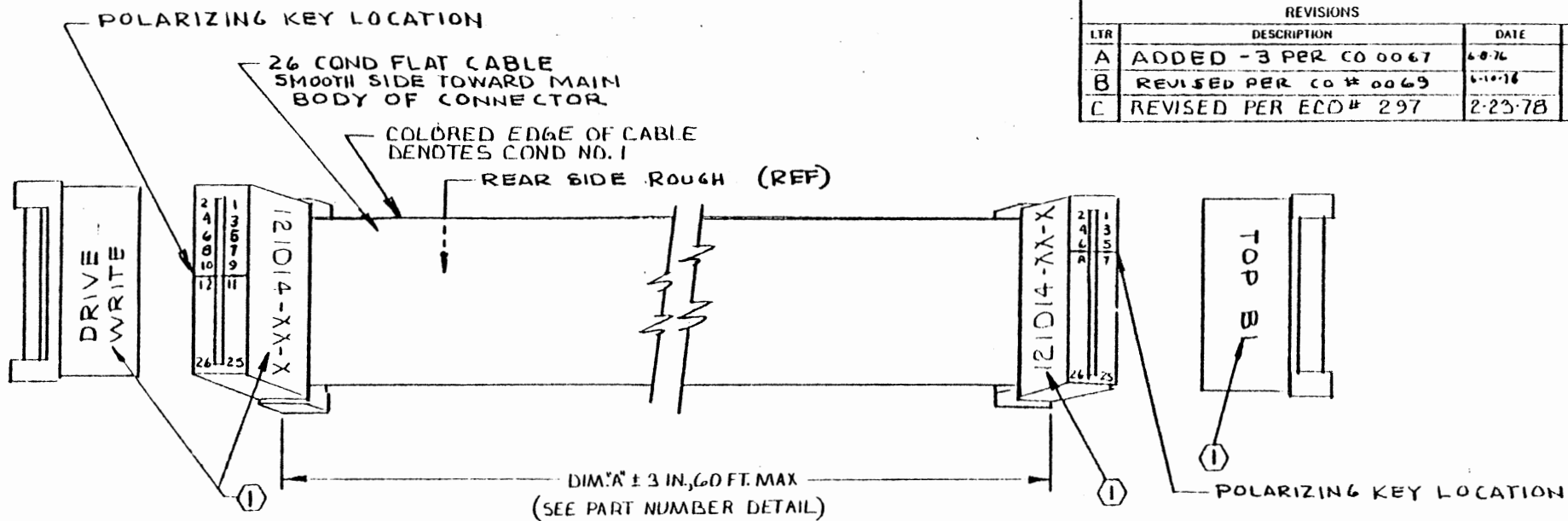

| REVISIONS | | | |
|-----------|-----------------------|---------|-------------|
| LTR | DESCRIPTION | DATE | APPROVED |
| A | ADDED - 3 PER CO 0067 | 6-8-76 | N.D. |
| B | REVISED PER CO # 0069 | 6-10-76 | N.D. |
| C | REVISED PER ECO # 297 | 2-23-78 | N.D., 11-78 |

NOTE 5:

- ① MARK CHARACTERS SHOWN USING CONTRASTING COLOR INK.
SEE PART NUMBER DETAIL FOR MARKING OF VARIABLE CHARACTERS (X'S).

2. ASSEMBLY:

USE 3M PRESS NO. 3440.
 USE LOCATOR PLATE NO 3443-11
 USE SETTING NO 9 OF GAUGE 3436-1
 CUT CABLE USING SCOTCHFLEX CABLE SHEAR OR EQUIV.
 SEAT CABLE INTO COVER USING SCOTCHFLEX
 TOOL NO 3453, CHECK FOR ALIGNMENT
 PLACE BODY ON LOCATOR PLATE
 POSITION COVER AND CABLE OVER CONN BODY
 LOWER HANDLE TO COMPLETE ASSY
 REMOVE BY LIFTING ON CONNECTOR

121014-XX-X

BASIC PART NUMBER _____

DASH NUMBER IN FEET (REF. DIM. "A") _____

(-07 FOR 7 FT., -10 FOR 10 FT., ETC.) _____

LATEST REVISION LETTER _____

FOR PARTS SEE PARTS LIST 121014

| | | | |
|---------------------------------------|--------|---|-----------------------------------|
| TOLERANCES UNLESS OTHERWISE SPECIFIED | | western peripherals <small>ANAHEIM, CALIFORNIA</small> | |
| FRACTIONS | DEC. | | |
| ± | 1 | ± | ASSEMBLY- CABLE, WRITE |
| APPROVALS | DATE | SCALE | |
| DRAWN C. SCUTA | 6-1-76 | NONE | |
| CHECKED N.D. | 6-1-76 | SIZE | DRAWING NO |
| | | B | 121014 |
| | | DO NOT SCALE DRAWING | SHEET |

| REVISIONS | | | |
|-----------|------------------------------|---------|---------------|
| LTR | DESCRIPTION | DATE | APPROVED |
| A | REV PER CO NO. 0105 | 9-8-76 | |
| B | E.C.O NO. -0190 | 6-6-77 | <i>J.D.</i> |
| C | REVISED NOTE 2 PER ECO. #415 | 2/2/79 | <i>J.D.</i> |
| D | ADDED NOTE (4) PER ECO # 504 | 6-20-79 | <i>K.H.C.</i> |

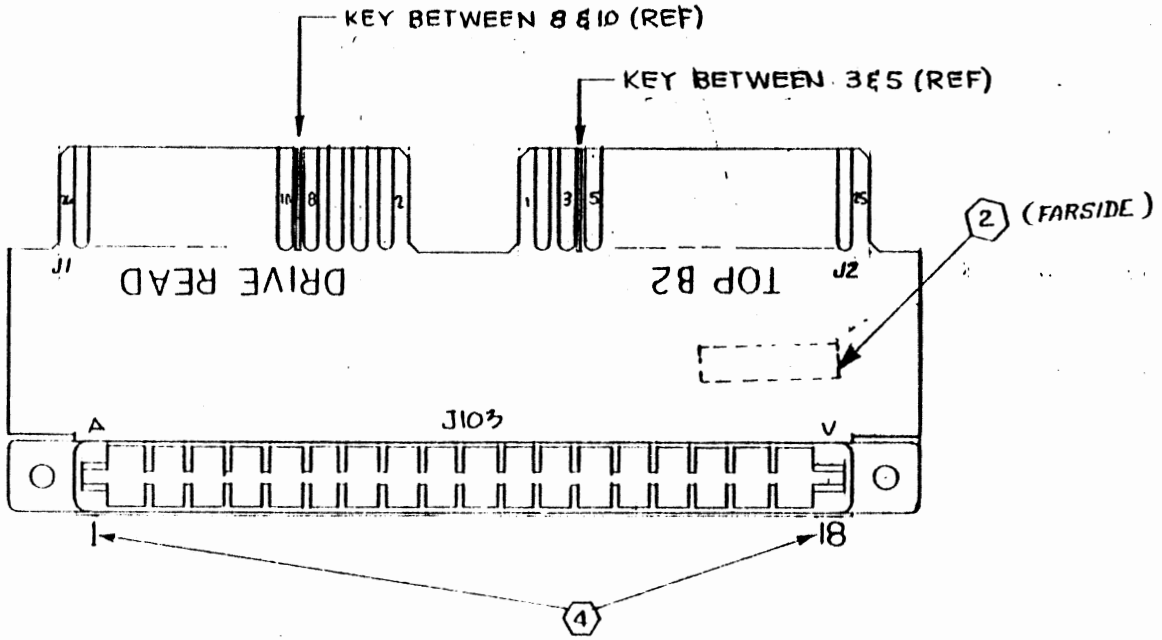

- NOTE.
- REF SCHEMATIC DWG NO. 122022
 - (2)* RUBBER STAMP ASSEMBLY NO. WITH LATEST REV. LTR APPLICABLE WHERE SHOWN USING BLACK INK.
 - FOR MATL. SEE P/L 122005
 - (4)* MARK CHARACTERS SHOWN (1 & 18) ON SIDE OF CONNECTOR USING CONTRASTING INK.

| | | | |
|---------------------------------------|---------|---|---|
| TOLERANCES UNLESS OTHERWISE SPECIFIED | | western peripherals ANAHEIM, CALIFORNIA | |
| FRACTIONS | DEC. | ANGLES | ASSEMBLY DWG. ADAPTER, TAPE READ CONNECTOR |
| ± | ± | ± | |
| APPROVALS | DATE | SCALE | SIZE |
| DRAWN <i>HEB</i> | 2-13-76 | 2:1 | B |
| CHECKED <i>at.</i> | 2-25-76 | DRAWING NO. | 122005 |
| DO NOT SCALE DRAWING | | | SHEET 1 OF 1 |

COPYRIGHT © 1976 BY WESTERN PERIPHERALS, INC.

| REVISIONS | | | |
|-----------|------------------------------------|----------|---------------|
| LTR | DESCRIPTION | DATE | APPROVED |
| A | E.C.O. NO.-0190 | 6-6-77 | W.D. 6-11-77 |
| B | ADVANCED REV LTR TO AGREE WITH P/L | 11/29/77 | W.H.W. 1-6-78 |
| C | REVISED NOTE 2 PER ECO# 416 | 11/29/77 | W.H.W. 1-6-78 |
| D | ADDED NOTE (4) PER ECO# 504 | 6-20-78 | W.D. 6-11-77 |

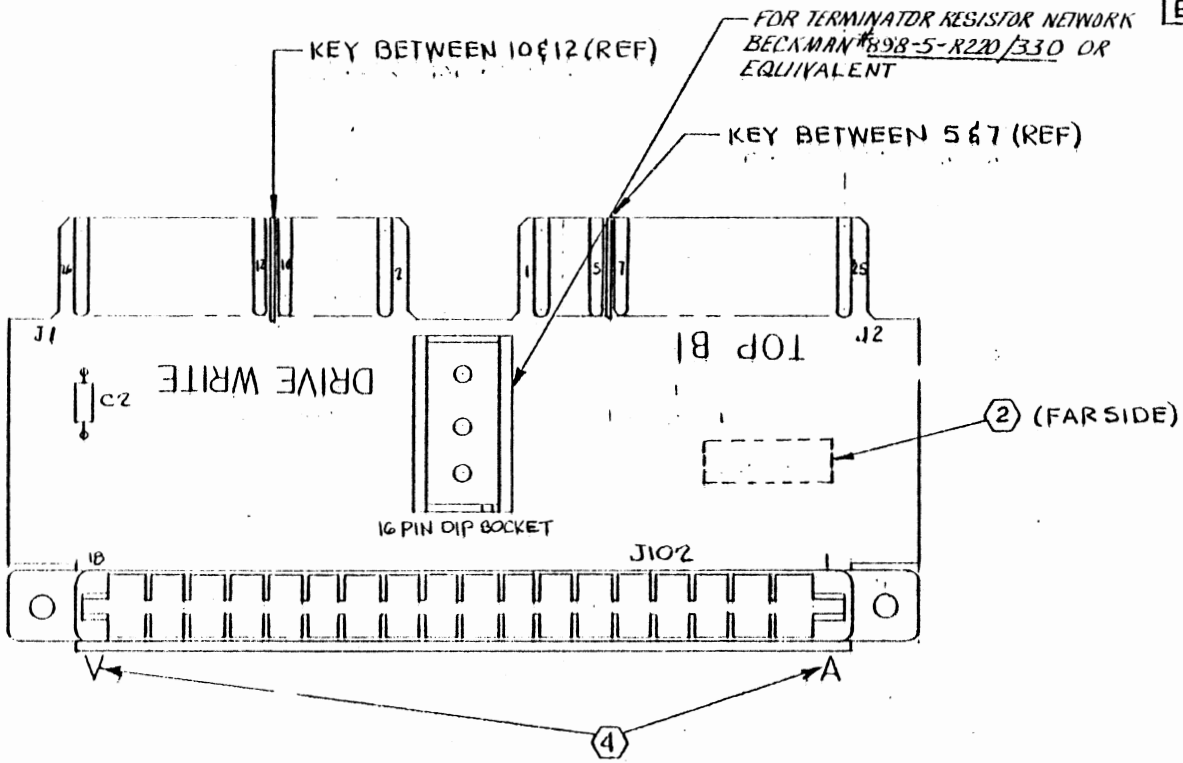

NOTE:

1. REF SCHEMATIC DWG. NO. 122021.
- (2) RUBBER STAMP ASSY NO. WITH LATEST REV LTR APPROX. WHERE SHOWN USING BLK INK.
3. FOR MATL SEE P/L 122006.
- (4) MARK CHARACTERS SHOWN (A&V) ON SIDE OF CONNECTOR USING CONTRASTING INK.

COPYRIGHT © 1976 BY WESTERN PERIPHERALS, INC.

| | | | |
|---------------------------------------|---------|--|--|
| TOLERANCES UNLESS OTHERWISE SPECIFIED | | western peripherals ANAHEIM, CALIFORNIA | |
| FRACTIONS | DEC. | | |
| ± | ± | ± | ASSEMBLY DWG. ADAPTER, TAPE WRITE CONNECTOR |
| APPROVALS | DATE | SCALE | |
| DRAWN HRB | 2-12-76 | 2:1 | |
| CHECKED WZ | 2-25-76 | SIZE B | DRAWING NO. 122006 |
| DO NOT SCALE DRAWING | | | SHEET 1 of 1 |

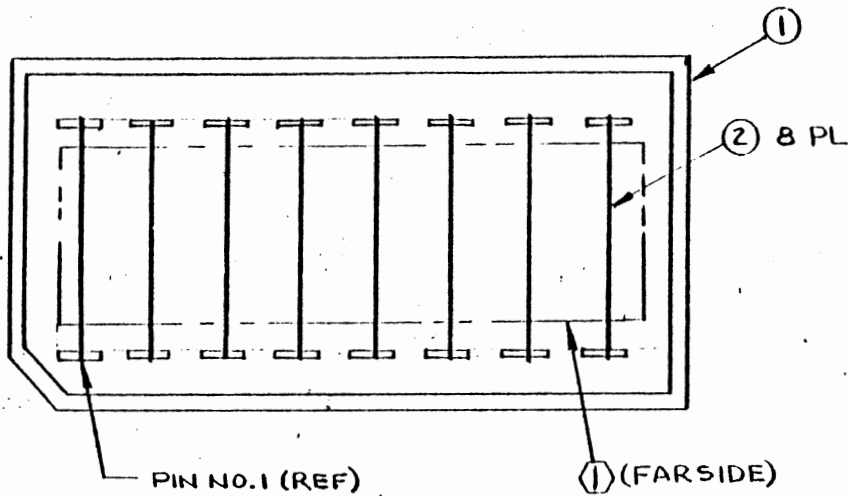

| REVISIONS | | | |
|-----------|-------------|------|----------|
| LTR | DESCRIPTION | DATE | APPROVED |
| | | | |

NOTE: UNLESS OTHERWISE SPECIFIED
 (1) AFFIX ADHESIVE LABEL WITH PART NO. & LATEST REV LTR WHERE SHOWN

| WIRE LIST | | |
|-----------|--------------|------------|
| WIRE NO. | FROM PIN NO. | TO PIN NO. |
| 1 | 1 | 16 |
| 2 | 2 | 15 |
| 3 | 3 | 14 |
| 4 | 4 | 13 |
| 5 | 5 | 12 |
| 6 | 6 | 11 |
| 7 | 7 | 10 |
| 8 | 8 | 9 |

BILL OF MATERIALS

| ITEM | NO. REQD | PART NO. | DESCRIPTION | REMARKS |
|------|----------|-----------|--------------------------------|-----------------------|
| 1 | 1 | CA-16P-12 | DIP PLUG, 16-PIN | CIRCUIT ASSY OR EQUIV |
| 2 | A/R | | WIRE, INSULATED, #30 AWG SOLID | WIRE WRAP WIRE |

| | | | |
|---|--|---|------------------------------|
| TOLERANCES UNLESS OTHERWISE SPECIFIED FRACTIONS DEC. ANGLES ± ± ± | | western peripherals ANAHAIM, CALIFORNIA | |
| APPROVALS | | DATE | |
| DRAWN CORONA | | 11-18-76 | |
| CHECKED Z. D. | | 11-18-76 | |
| SCALE NONE | | SIZE B | DRAWING NO. 122010 |
| DO NOT SCALE DRAWING | | | SHEET 1 OF 1 |

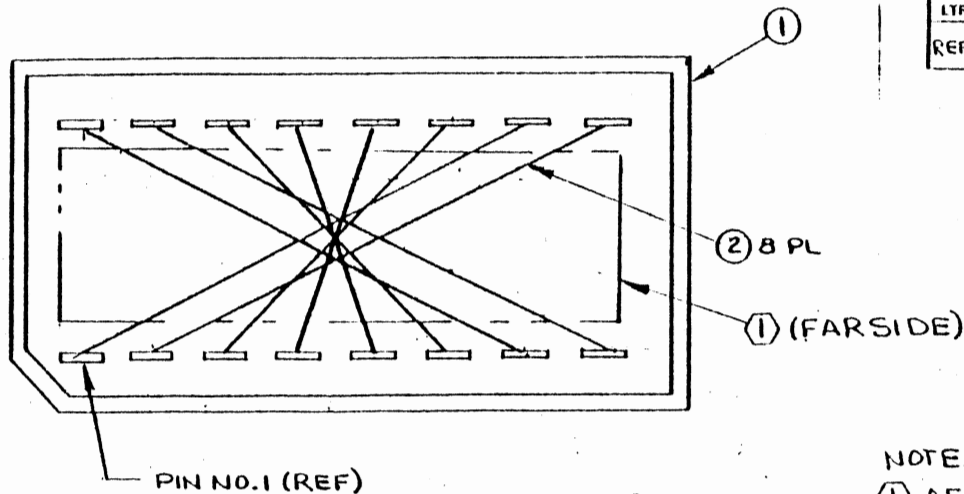

| REVISIONS | | | |
|-----------|--|------|----------|
| LTR | DESCRIPTION | DATE | APPROVED |
| REF | REC. CHG: ADD 'FARSIDE' TO (1) (ALL PARTS MADE CONFORM) | | |

| WIRE NO. | FROM PIN NO. | TO PIN NO. |
|----------|--------------|------------|
| 1 | 1 | 10 |
| 2 | 2 | 9 |
| 3 | 3 | 11 |
| 4 | 4 | 12 |
| 5 | 5 | 13 |
| 6 | 6 | 14 |
| 7 | 7 | 16 |
| 8 | 8 | 15 |

NOTE: UNLESS OTHERWISE SPECIFIED
 (1) AFFIX ADHESIVE LABEL WITH PART NO. &
 LATEST REV LTR WHERE SHOWN

BILL OF MATERIALS

| ITEM | NO. REQD | PART NO. | DESCRIPTION | REMARKS |
|------|----------|-----------|--------------------------------|-----------------------|
| 1 | 1 | CA-16P-12 | DIP PLUG, 16-PIN | CIRCUIT ASSY OR EQUIV |
| 2 | A/R | | WIRE, INSULATED, #30 AWG SOLID | WIRE WRAP WIRE |

| TOLERANCES UNLESS OTHERWISE SPECIFIED | | FRACTIONS DEC. ANGLES | | western peripherals <small>ANAHEIM, CALIFORNIA</small> | | | |
|---------------------------------------|----------|-----------------------|---|--|--|------|-------------|
| ± | ± | ± | ± | ASSY, JUMPER ARRAY, SELECT SWITCH OPTION, SPECIAL (4TH TRANSPORT) | | | |
| APPROVALS | DATE | SCALE | | | | SIZE | DRAWING NO. |
| DRAWN CORUM | 11-18-76 | NONE | | | | B | 122011 |
| CHECKED V.D. | 11-18-76 | DO NOT SCALE DRAWING | | SHEET 1 OF 1 | | | |

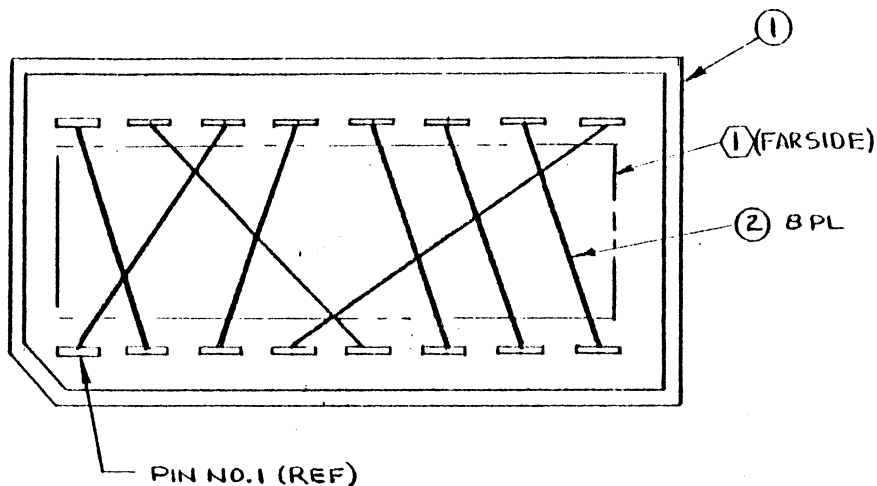

| REVISIONS | | | |
|-----------|-------------|------|----------|
| LTR | DESCRIPTION | DATE | APPROVED |
| | | | |

| WIRE LIST | | |
|-----------|--------------|------------|
| WIRE NO. | FROM PIN NO. | TO PIN NO. |
| 1 | 1 | 14 |
| 2 | 2 | 16 |
| 3 | 3 | 13 |
| 4 | 4 | 9 |
| 5 | 5 | 15 |
| 6 | 6 | 12 |
| 7 | 7 | 11 |
| 8 | 8 | 10 |

NOTE: UNLESS OTHERWISE SPECIFIED
 ① AFFIX ADHESIVE LABEL WITH PART NO. & LATEST REV LTR WHERE SHOWN

BILL OF MATERIALS

| ITEM | NO. REQD | PART NO. | DESCRIPTION | REMARKS |
|------|----------|-----------|--------------------------------|-----------------------|
| 1 | 1 | CA-16P-12 | DIP PLUG, 16-PIN | CIRCUIT ASSY OR EQUIV |
| 2 | A/R | | WIRE, INSULATED, #30 AWG SOLID | WIRE WRAP WIRE |

TOLERANCES UNLESS OTHERWISE SPECIFIED
 FRACTIONS DEC. ANGLES
 ± ± ±



ASSY, JUMPER ARRAY, NON-SELECT SWITCH OPTION

| APPROVALS | DATE |
|-----------------|----------|
| DRAWN CORDEA | 11-18-76 |
| CHECKED J.D. | 11-18-76 |

| SCALE | SIZE | DRAWING NO. |
|-------|------|-------------|
| NONE | B | 122012 |

| REVISIONS | | | | |
|-----------|--------------------------------|----------|---------------|--|
| LTR | DESCRIPTION | DATE | APPROVED | |
| A | INCORP. CO # 0145 <i>mc</i> | 1-21-77 | H.D. 1-24-77 | |
| B | E.C.O. NO. - 0190 | 6-6-77 | H.D. 6-11-77 | |
| C | DELETED NOTE 2 PER E.C.O. #417 | 11-11-79 | H.H. 11-14-79 | |
| D | ADDED NOTE ⑤ PER ECO #504 | 6-20-79 | K.W. 6-20-79 | |

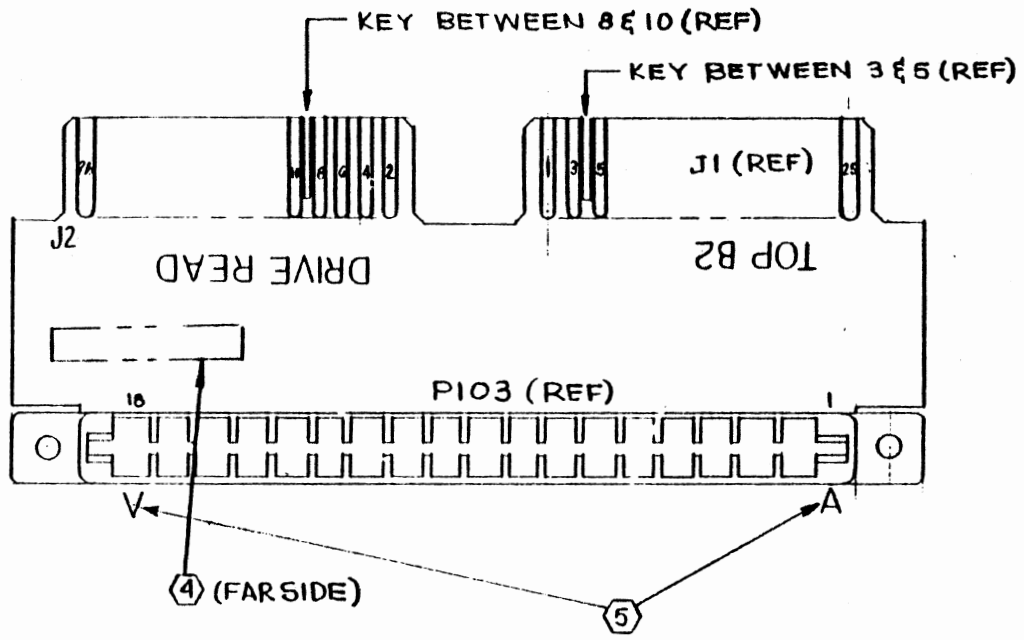

- NOTE: UNLESS OTHERWISE SPECIFIED
- REF SCHEMATIC DWG NO. 122022
 -
 - FOR MATERIAL SEE P/L 122018
 - RUBBER STAMP ASSY NO. WITH LATEST REV LTR APPROX WHERE SHOWN USING BLK INK.
 - MARK CHARACTERS SHOWN (A&V) ON SIDE OF CONNECTOR USING CONTRASTING INK.

COPYRIGHT © 1976 BY WESTERN PERIPHERALS, INC.

| | | | |
|---------------------------------------|---------|---|--------------|
| TOLERANCES UNLESS OTHERWISE SPECIFIED | | western peripherals ANAHEIM, CALIFORNIA | |
| FRACTIONS DEC. | ANGLES | ASSEMBLY DWG. | |
| ± ± ± | ± | ADAPTER, TAPE READ | |
| APPROVALS | DATE | KENNEDY CIPHER | |
| DRAWN <i>HRB</i> | 2-15-76 | SCALE | SIZE |
| CHECKED <i>AL</i> | 2-15-76 | 2:1 | B |
| | | DRAWING NO. | |
| | | 122018 | |
| DO NOT SCALE DRAWING | | | SHEET 1 OF 1 |

| REVISIONS | | | |
|-----------|--------------------------------------|----------|----------------|
| LTR | DESCRIPTION | DATE | APPROVED |
| A | INCORPORATE CO # 0146 | 1-21-77 | J.D. 1-24-77 |
| B | INCORP. ECO 172 | 5/11/77 | J.D. 5-11-77 |
| C | INCORP. ECO. NO. - 0190 | 6-6-77 | J.D. 6-11-77 |
| D | DELETED NOTE 2 & CALLOUT PER ECO 118 | 11/24/79 | J.H.W. 1-19 |
| E | ADDED NOTE (5) PER ECO # 504 | 6-20-79 | Cons. C. 10-79 |

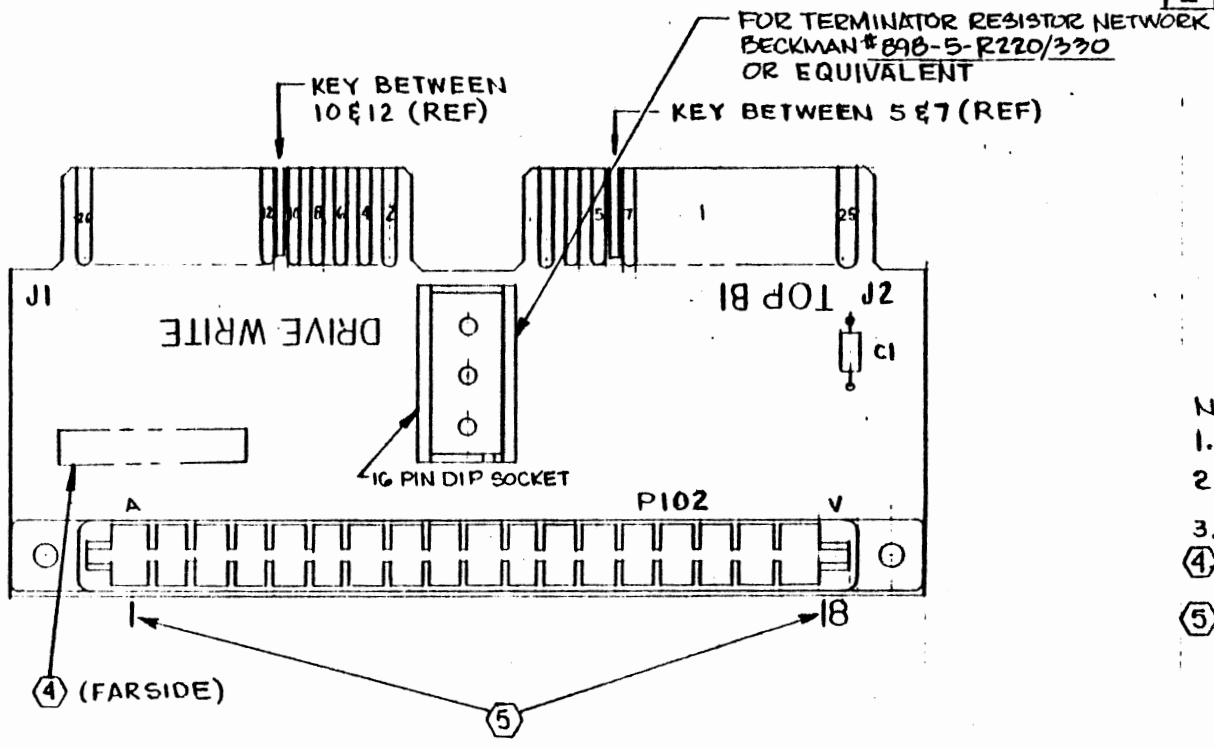

NOTE: UNLESS OTHERWISE SPECIFIED
 1. REF SCHEMATIC DWG NO. 122021
 2.
 3. FOR MATERIAL SEE P/L 122019
 (4) RUBBER STAMP ASSY NO. WITH LATEST REV LTR APPROX WHERE SHOWN
 (5) MARK CHARACTERS (1 & 18) ON SIDE OF CONNECTOR USING CONTRASTING INK.

COPYRIGHT © 1976 BY WESTERN PERIPHERALS, INC.

| | | | | |
|---------------------------------------|-------------|--|-----------------|-------------|
| TOLERANCES UNLESS OTHERWISE SPECIFIED | | western peripherals ANAHEIM, CALIFORNIA | | |
| FRACTIONS | DEC. ANGLES | | | |
| ± | ± ± | ASSEMBLY DWG. ADAPTER, TAPE WRITE KENNEDY-CIPHER | | |
| APPROVALS | DATE | SCALE | SIZE | DRAWING NO. |
| DRAWN | | | | |
| CHECKED | | 2:1 | B | 122019 |
| DO NOT SCALE DRAWING | | | SHEET of | |

DAISY-CHAIN TO NEXT TAPE DRIVE

| | | | |
|---|---|---------|--------|
| B | INCOMP ECO 172 | 5/11/77 | (A, D) |
| C | IDENTIFIED SIGNALS AND CONNECTORS PER ECO 169 | 9-18-80 | (A, D) |

| REVISIONS | | DATE | APPROVED |
|-----------|-------------|---------|----------|
| LTR | DESCRIPTION | | |
| A | ECO-0147 | 8-30-77 | (A, D) |

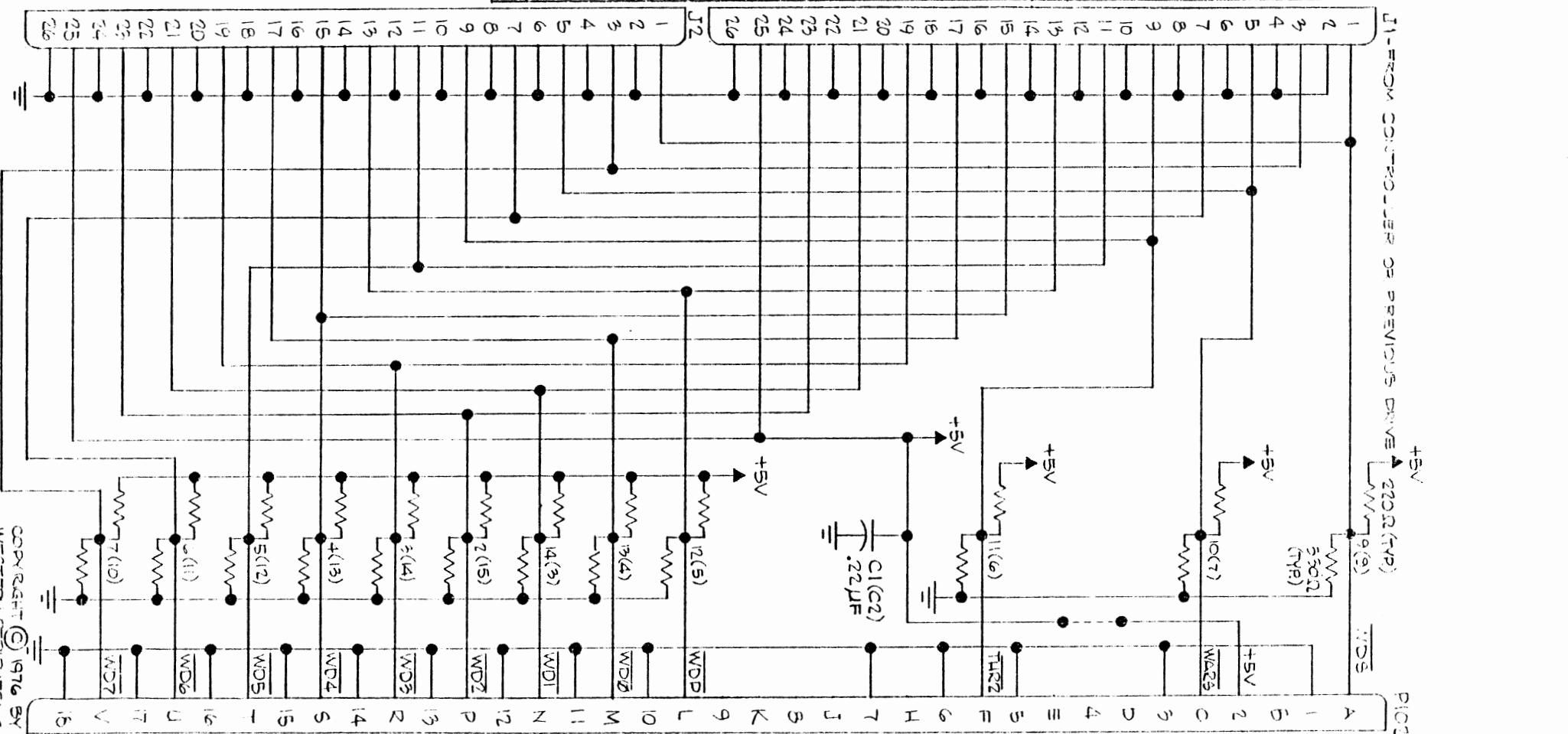

TO
TAPE
DRIVE

NOTES:

1. NEXT ASSY. NO: 122006, 122034.
2. PIN NUMBERS AND REFERENCE DESIG-NATIONS SHOWN IN PARENTHESES APPLY TO ASSY. 122006, 122034.

| | | | |
|---|--|---|-----------------------|
| TOLERANCES UNLESS OTHERWISE SPECIFIED FRACTIONS DEC. ANGLES | | western peripherals ANAHEIM, CALIFORNIA | |
| APPROVALS DRAWN <i>HRB</i> CHECKED <i>RL</i> | | DATE 1-12-76 1-26-76 | |
| SCALE NONE | | SIZE B | DRAWING NO. 122021 |
| DO NOT SCALE DRAWING | | | SHEET 1 OF 1 |

COPYRIGHT © 1976 BY WESTERN PERIPHERALS, INC.

| REVISIONS | | DATE | APPROVED |
|-----------|--|---------|----------|
| LT# | DESCRIPTION | | |
| A | ISSUED FIELD SIGNALS AND CONNECTORS REV. 100-1169 | 9-18-80 | |

DI - FROM CONTROLLER OR PREVIOUS DRIVE

DAIRY-CHAIN TO NEXT TAPE DRIVE

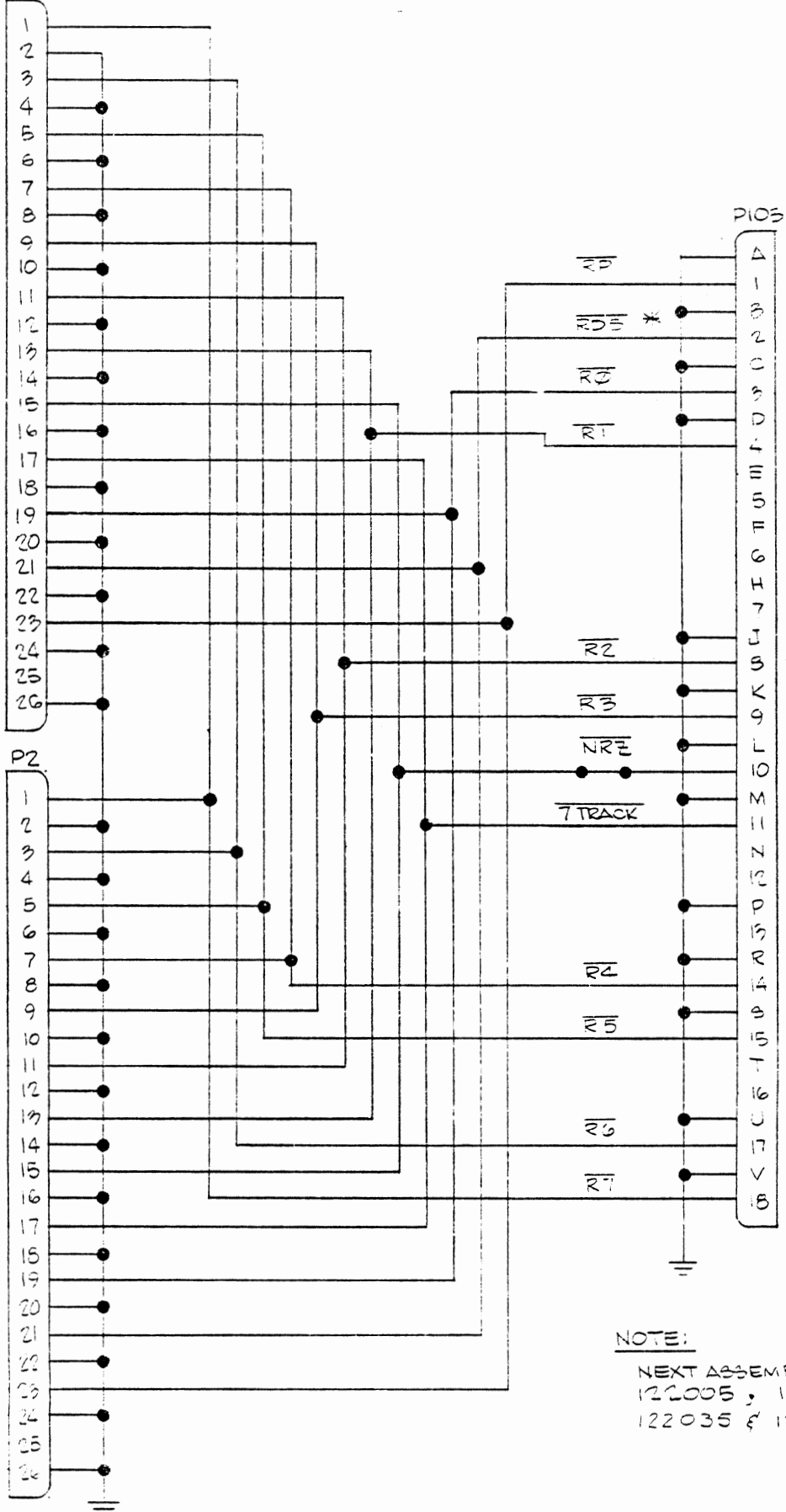

NOTE:
NEXT ASSEMBLY NO.
122005, 122018,
122035 & 122043.

| | |
|--|---|
| western peripherals ANAHEIM, CALIFORNIA | |
| SCHEMATIC ADPTR., TAPE READ CONNECTOR | |
| TOLERANCES UNLESS OTHERWISE SPECIFIED FRACTIONS DEC. ANGLES | APPROVALS DATE DRAWN HLB 1-13-76 CHECKED JH 1-16-76 |
| SCALE NONE B | DRAWING NO. 122022 |
| DO NOT SCALE DRAWING | |

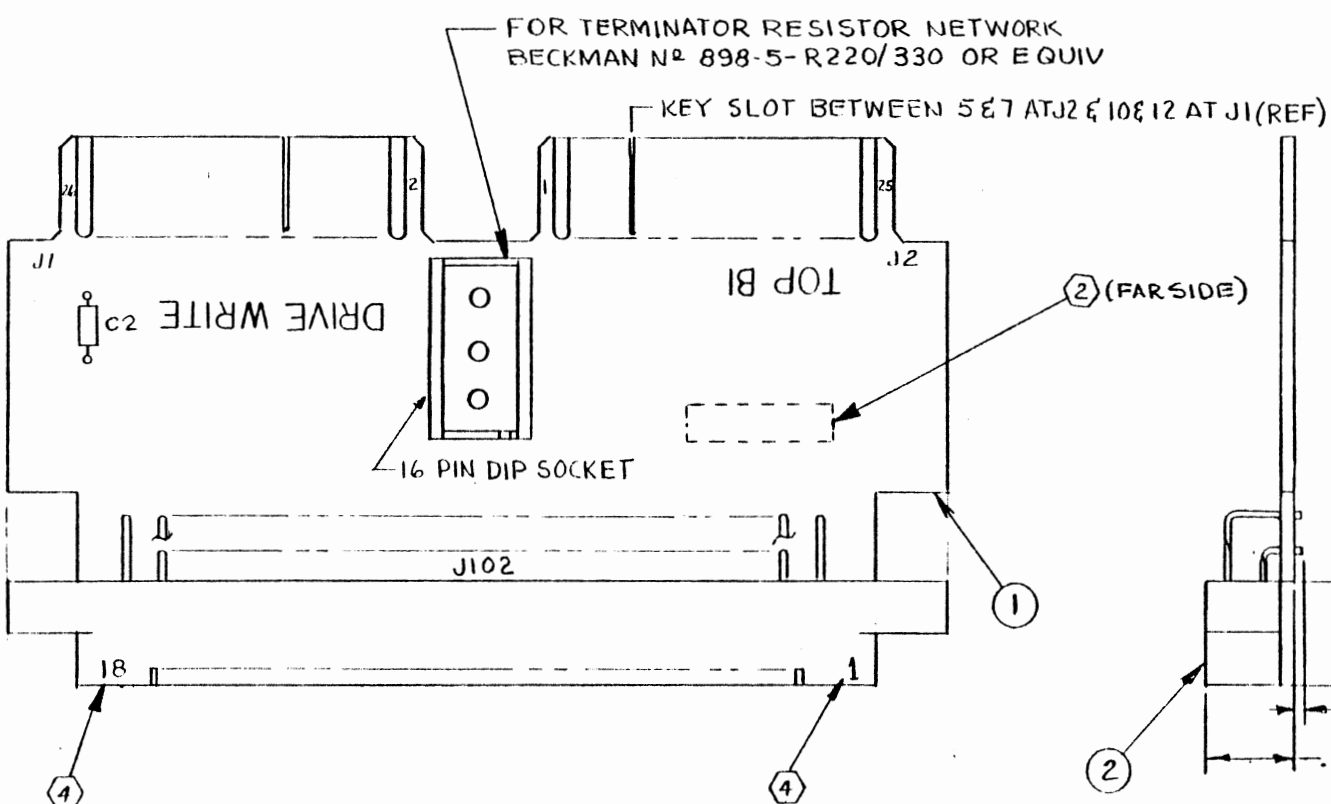

| REVISIONS | | | |
|-----------|--|---------|------------|
| LTR | DESCRIPTION | DATE | APPROVED |
| A | INCORP ECO 172 | 5/11/77 | J.D. Smith |
| B | INCORP E.C.O. NO. 0190 | 6-6-77 | J.D. Smith |
| C | INCORP E.C.O. NO. 0197 | 8-8-77 | J.D. Smith |
| D | ADD NOTE 4 PER ECO 355 | | |
| E | ADVANCE REV LTR TO AGREE WITH P/L | | |
| F | CHANGED NOTE 2 PER ECO 416 | | |
| G | INC ECO# 852 AND CHG ASSY NO. LOCATION | 3/24/81 | |

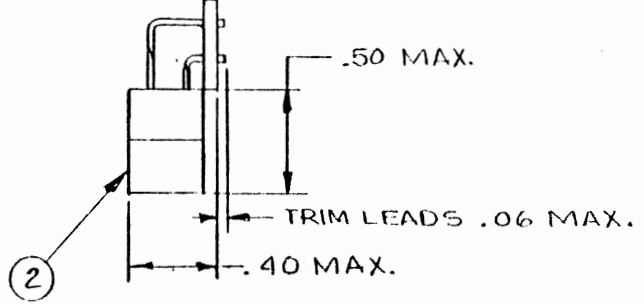

- ④ RUBBER STAMP CHARACTERS SHOWN USING WHITE INK.
 - ③ FOR MATERIAL LIST SEE P/L 122034.
 - ② RUBBER STAMP ASSY NO. & LATEST REV LTR APPROX WHERE SHOWN USING P/LK INK.
 - ① REF. SCHEMATIC DWG NO. 122021.
- NOTE: UNLESS OTHERWISE SPECIFIED.

MAR 27 1981

| | | | |
|---------------------------------------|---------|---|--|
| TOLERANCES UNLESS OTHERWISE SPECIFIED | | western peripherals ANAHEIM, CALIFORNIA | |
| FRACTIONS | DEC. | | |
| ± | ± | ± | ASSEMBLY- ADAPTER TAPE WRITE KENNEDY 9800 |
| APPROVALS | DATE | | |
| DRAWN CORUM | 6-11-76 | SCALE 2X | SIZE B |
| CHECKED | | DRAWING NO. 122034 | |
| DO NOT SCALE DRAWING | | | SHEET 1 OF 1 |

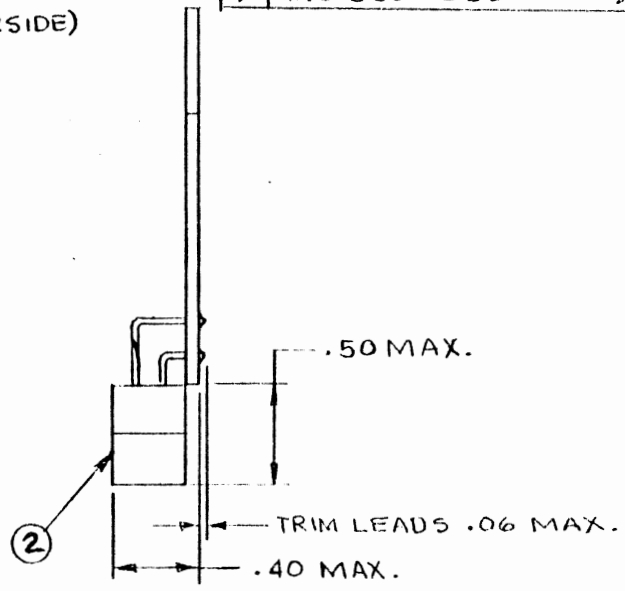
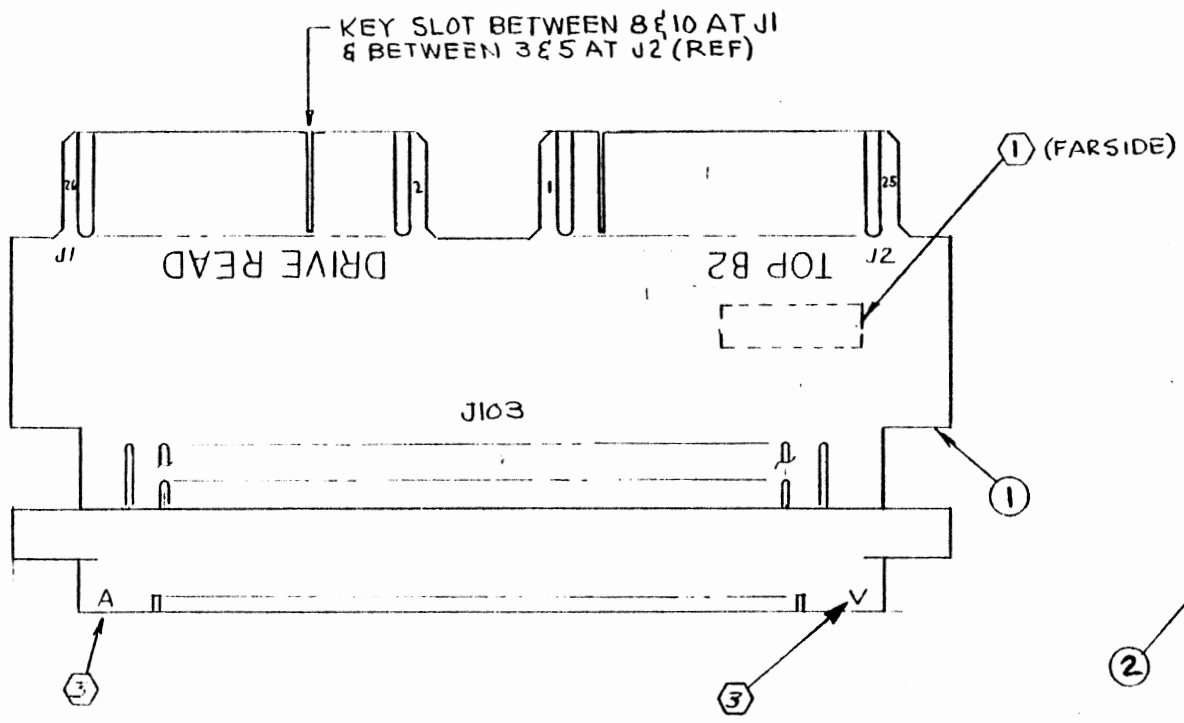

| REVISIONS | | | |
|-----------|------------------------------------|---------|--------------|
| LTR | DESCRIPTION | DATE | APPROVED |
| A | E.C.O. NO-0190 | 6-6-77 | N.S. 6-11-77 |
| B | E.C.O. NO-0197 | 8-8-77 | N.S. 8-9-77 |
| C | ADDED NOTE 3 PER ECO #355 | 11/2/77 | 11/2/77 |
| D | ADVANCED REV LTR TO AGREE WITH P/L | 11/2/77 | 11/2/77 |
| E | CHANGED NOTE 1 PER ECO #415 | 11/2/77 | 11/2/77 |
| F | INC ECO # 852 | 11/2/77 | 11/2/77 |

MAR 27 1981

- (3) RUBBER STAMP CHARACTERS SHOWN USING WHITE INK.
 - 2. REF SCHEMATIC DWG NO. 122035.
 - (1) RUBBER STAMP Assy NO. 4 LATE ST REV LTR APPROX WHEAT SHOWN USING BIK INK.
- NOTE : UNLESS OTHERWISE SPECIFIED.

| | | | |
|---------------------------------------|---------|---|--|
| TOLERANCES UNLESS OTHERWISE SPECIFIED | | western peripherals ANAHEIM, CALIFORNIA | |
| FRACTIONS | DEC. | | |
| ± | ± | ± | ASSEMBLY-ADAPTER TAPE READ KENNEDY 9800 |
| APPROVALS | DATE | SCALE | |
| DRAWN C. G. D. H. A. | 6-11-76 | 2 X | |
| CHECKED Acc. | | SIZE B | DRAWING NO. 122035 |
| DO NOT SCALE DRAWING | | | SHEET 1 OF 1 |

| REVISIONS | | | |
|-----------|---|---------|--------------------|
| LTR | DESCRIPTION | DATE | APPROVED |
| A | CORRECTED SWITCH SETTING CHART FOR SA4 PER ECO 118. | 5-4-77 | |
| B | REDRAWN PER ECO 236. | 5-16-78 | <i>[Signature]</i> |
| C | CHANGED I.C. LOC'N PER ECO 806 | 12-9-78 | <i>[Signature]</i> |

| SWITCH A | SWITCH SETTINGS | SYSTEM CONSIDERATIONS |
|----------|--|--|
| 1 | ON FOR DRIVES THAT REQUIRE REWIND COMMAND REMOVAL PRIOR TO BOT | 1. REMOVE ALL INTERFACE TERMINATORS FROM TRANSPORT(S) 2. INSTALL CONTROL TERMINATOR ONLY IN LAST DAISY CHAIN POSITION |
| | OFF FOR DRIVES THAT DO NOT REQUIRE REWIND COMMAND REMOVAL PRIOR TO BOT | |
| 2 | ON FOR DRIVES THAT STORE EOT STATUS NOTE: A5 SHOULD BE OFF | 3. CORRECTLY IDENTIFY CONFIGURATION AND SET SWITCHES ACCORDINGLY |
| | OFF FOR DRIVES THAT DO NOT STORE EOT STATUS NOTE: A5 SHOULD BE ON | |
| 3 | ON FOR 7 TRACK DRIVES | NOTES: 1. FOR 7 TRACK DRIVES IN DRIVE DAISY CHAINS, ONLY PRIMARY SPEED SELECTION IS AVAILABLE. 2. REF. ASSY. DWG. 122037, 122038, & 122039. ③ 122010 INSTALLED WHEN TRANSPORT HAS 4- POSITION UNIT SELECT SWITCH (SEE EXCEPTION BELOW). 122011 INSTALLED IN 4 TH TRANSPORT IF MORE THAN 4 TRANSPORTS ARE DAISY CHAINED. 122012 INSTALLED WHEN TRANSPORT DOES NOT HAVE UNIT SELECT SWITCH. ④ FOR PERTEC COMPATIBLE UNIT SELECT OPTION: JUMPER E TO F, G TO H, AND M TO N. ⑤ FOR EXTERNALLY CONNECTED UNIT SELECT SWITCH: CUT ETCH BETWEEN P & R AND CONNECT EXTERNAL SWITCH TO A, B, C, D, & L. ⑥ TO POWER ADAPTER FROM TAPE TRANSPORT, CUT ETCH BETWEEN J & S AND JUMPER J TO K. 7. FOR CONFIGURATION "L" SEE DWG. 130047. 8. FOR CONFIGURATION "N" SEE DWG. 122044. 9. FOR CONFIGURATION "S" SEE DWG. 112061. |
| | OFF FOR 9 TRACK DRIVES | |
| 4 | ON FOR 7 TRACK 556/800 BPI DENSITY SELECTIONS OR 9 TRACK SECONDARY SPEED (SELECTION B) | |
| | OFF FOR 7 TRACK 200/556 BPI DENSITY SELECTIONS OR 9 TRACK PRIMARY SPEED (SELECTION A) | |
| 5 | ON FOR DRIVES THAT DO NOT STORE EOT STATUS NOTE: A2 SHOULD BE OFF | |
| | OFF FOR DRIVES THAT STORE EOT STATUS NOTE: A2 SHOULD BE ON | |
| 6 | ON FOR 9 TRACK NRZI ONLY DRIVE | |
| | OFF FOR 7 TRACK DRIVES, 9 TRACK 1600 BPI DRIVES, OR 9 TRACK 800/1600 DUAL DENSITY | |
| 7 | ON FOR DUAL DENSITY 9 TRACK DRIVES THAT DO NOT PRESENT NRZ STATUS ON DRIVE READ CONNECTOR | |
| | OFF FOR DUAL DENSITY 9 TRACK DRIVES THAT DO PRESENT NRZ STATUS ON DRIVE READ CONNECTOR | |
| 8 | ON FOR 7 TRACK DRIVES | |
| | OFF FOR 9 TRACK DRIVES | |

| | |
|---------------------------------------|-------------|
| TOLERANCES UNLESS OTHERWISE SPECIFIED | |
| FRACTIONS | DEC. ANGLES |
| ± | ± |
| APPROVALS | DATE |
| DRAWN T.M. | 2-15-78 |
| CHECKED J.D. | 5-14-78 |

 **western peripherals**
ANAHEIM, CALIFORNIA

SCHEMATIC
TAPE CONTROL ADAPTER

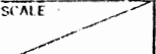
SCALE:  SIZE: **B** DRAWING NO. 122036

DO NOT SCALE DRAWING SHEET 1 OF 3

* SELECT JUMPER ARRAY P/N 122012

REVISIONS

| LTR | DESCRIPTION | DATE | APPROVED |
|-----|-------------|------|----------|
| | | | |

- J1
- SLT0 11
- SLT1 13
- SLT2 15
- SLT3 9
- SLT4 7
- SLT5 5
- SLT6 1
- SLT7 3
- FLPT 17
- FSL 33
- RSL 23
- OVW 21
- WNB 19
- RWDC 27
- DSL 29

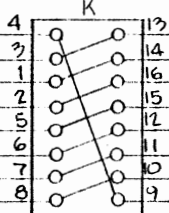

- J2
- 11
- 13
- 15
- 9
- 7
- 5
- 1
- 3
- 17
- 33
- 23
- 21
- 19
- 27
- 29

(TO NEXT DRIVE
IN DAISY CHAIN)

- J101
- P FLPT
- C FSL
- E RSL
- B OVW
- K WNB
- D DSL
- J
- A
- 18
- V
- 3

+5V { 35
37

RWDC-2
OVW-2
RSL-2
FSL-2

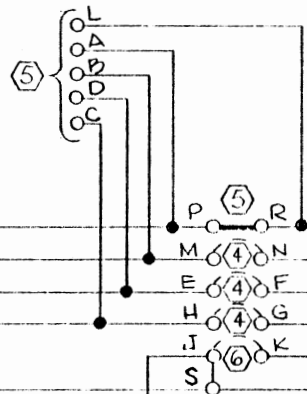

INSTALLED FOR SINGLE
TRANSPORT OR LAST UNIT
IF UNITS ARE DAISY CHAINED

+5V TO ADAPTER

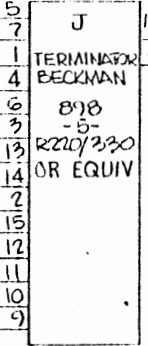

TERMINATOR
BECKMAN
898
-5-
R220/330
OR EQUIV

* SELECT JUMPER ARRAY
ALTERNATES

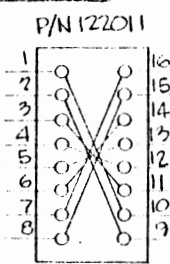
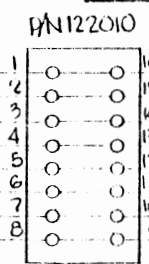

- NOTES: UNLESS OTHERWISE SPECIFIED
- J1 & J2 HAVE ALL EVEN NUMBERED GROUND PINS.
 - J101 GROUND PINS ARE 2-14, 16 & 17.
 - ALL RESISTORS ARE 10K OHMS.

(FROM CONTROLLER
OR PREVIOUS DRIVE)

| | |
|---------------------------------------|-------------|
| TOLERANCES UNLESS OTHERWISE SPECIFIED | |
| FRACTIONS | DEC. ANGLES |
| ± | ± |
| APPROVALS | DATE |
| DRAWN: HED | |
| CHECKED | |



**SCHEMATIC - TAPE
CONTROL ADAPTER**

| | | |
|----------------------|----------|--------------|
| SCALE | SIZE | DRAWING NO. |
| | B | 122036 |
| DO NOT SCALE DRAWING | | SHEET 2 OF 3 |

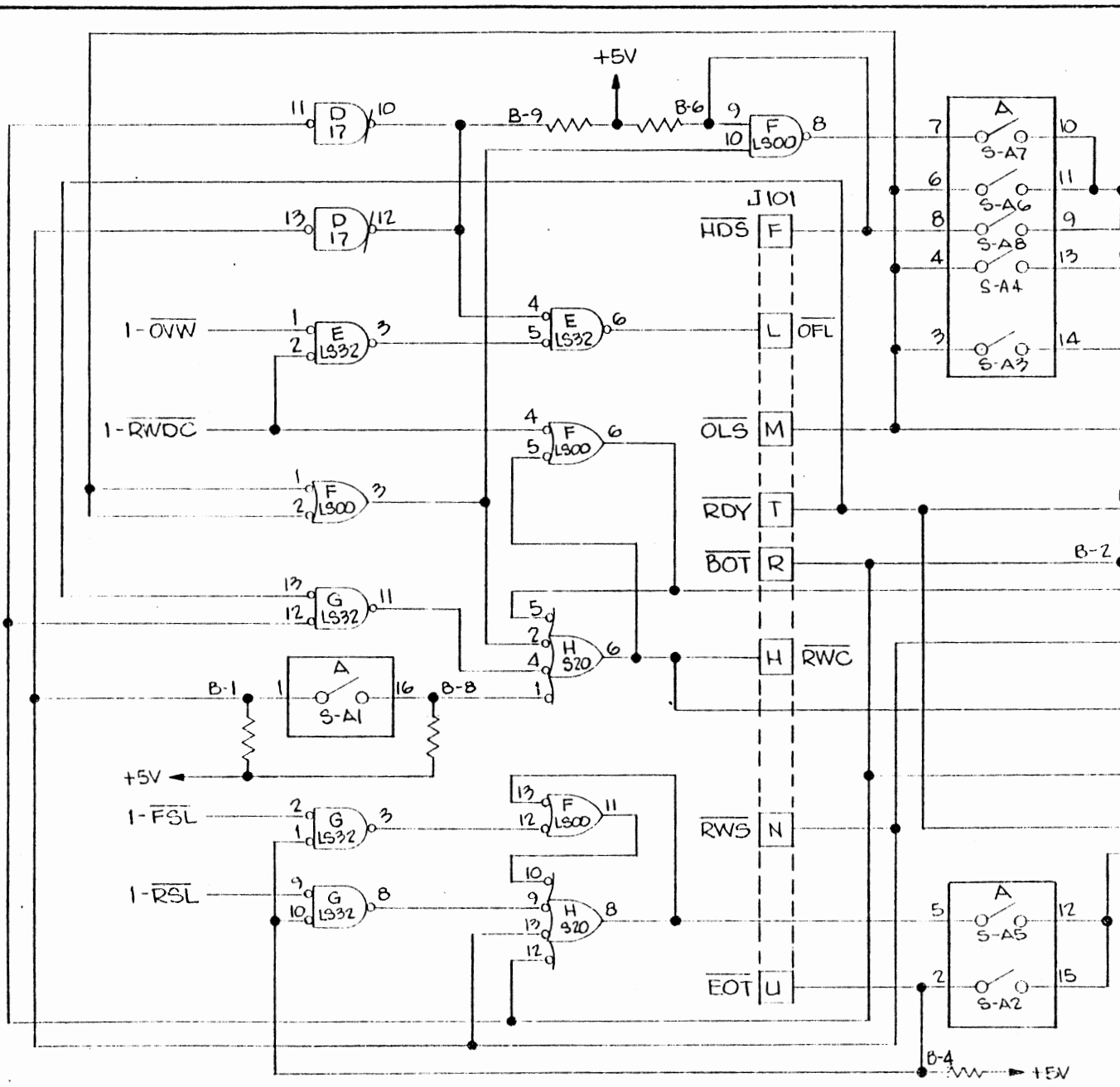

| REVISIONS | | | |
|-----------|-------------|------|----------|
| LTR | DESCRIPTION | DATE | APPROVED |

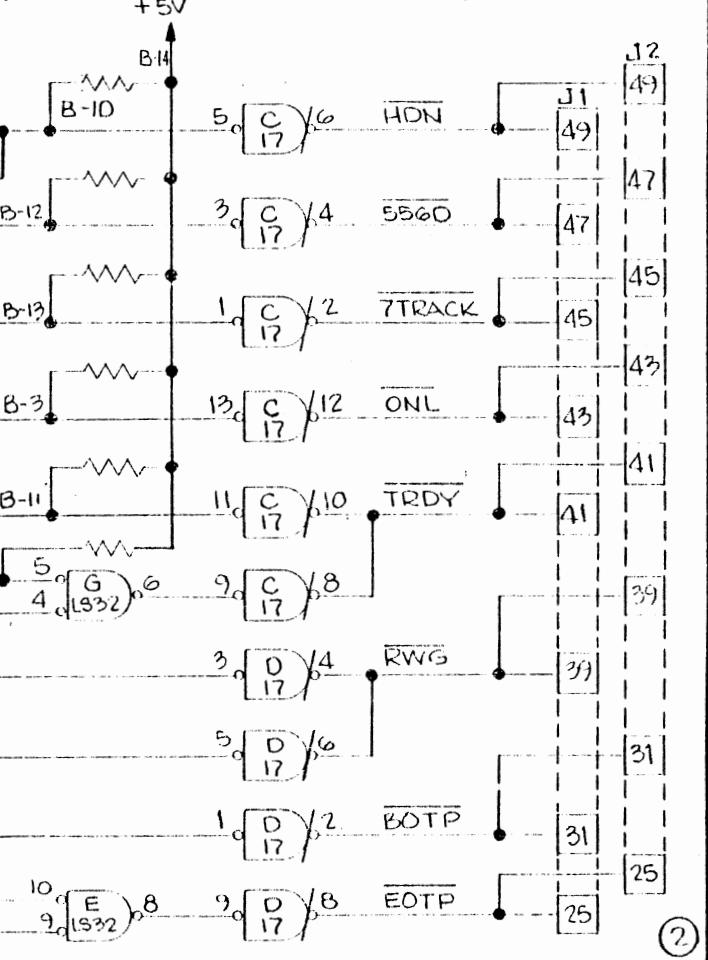

| | |
|---------------------------------------|-------------|
| TOLERANCES UNLESS OTHERWISE SPECIFIED | |
| FRACTIONS | DEC. ANGLES |
| ± | ± |
| APPROVALS | DATE |
| DRAWN HRS | |
| CHECKED | |

western peripherals
ANAHEIM, CALIFORNIA

SCHEMATIC - TAPE CONTROL ADAPTER

| | | |
|----------------------|------------------|-----------------------|
| SCALE | SIZE B | DRAWING NO. 122036 |
| DO NOT SCALE DRAWING | | SHEET 3 OF 3 |

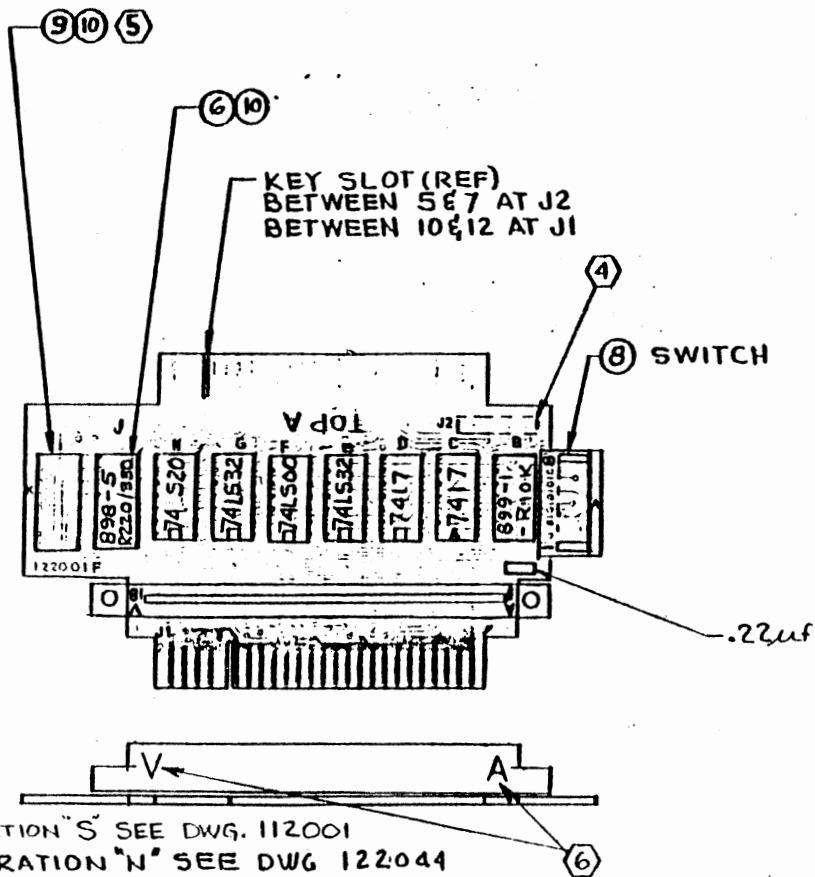

| REVISIONS | | | |
|-----------|---|----------|---------------|
| LTR | DESCRIPTION | DATE | APPROVED |
| A | E.C.O. NO.-0143 | 1-18-77 | |
| B | E.C.O. NO.-0190 | 6-5-77 | N.D. 11-77 |
| | RECORD CHANGE: ADD CONF. "L" (REV. LTR. CHANGE NOT REQD.) | 8-9-77 | N.D. 8-9-77 |
| | RECORD CHG: ADD CONF'N' (REV LTR CHG NOT REQD) | 9-28-77 | N.D. 9-28-77 |
| | RECORD CHG: ADD SH NO. 2 (ASSEMBLY NO CHG TO BASIC BD SEE ECO # 0254 (NO REV. LTR REQD)) | 11-14-77 | N.D. 11-22-77 |
| | ECO # 299 (NO REV. LTR. CHANGE) | 3-8-78 | N.D. 3-7-78 |
| C | USE "F" REV. PWB, REF. ECON. 236A | 5-16-78 | N.D. 5-16-78 |
| D | DELETED NOTES 3 & 6 PER ECO 114 | 11-22-79 | N.D. 11-22-79 |
| E | CORRECT VALUE SHOWN FOR CAPACITOR PER ECO No. 460 | 3-6-79 | N.D. 3-6-79 |
| F | ADDED NOTE 6 PER ECO # 504 | 6-20-77 | N.D. 6-20-77 |

G 1C "H" S/B 74520 ECO 806

- 9. FOR CONFIGURATION "S" SEE DWG. 112001
- 8. FOR CONFIGURATION "N" SEE DWG 122044
- 7. FOR CONFIGURATION "L" SEE DWG. 130041

- 6. MARK CHARACTERS SHOWN (A & V) ON SIDE OF CONNECTOR USING CONTRASTING INK.
 - 5. FOR OPTIONAL JUMPERING AND/OR JUMPER ARRAYS, REF J.O.A. & SCHEMATIC
 - 4. RUBBER STAMP ASSY NO. WITH LATEST REV LTR AND DASH NO. (IF REQD) APPROX WHERE SHOWN (FAR SIDE)
 - 3.
 - 2. FOR MATERIAL SEE P/L NO. 122037
 - 1. REF SCHEMATIC 122036
- NOTE: UNLESS OTHERWISE SPECIFIED

BASIC ASSY SHOWN
FOR -1 ASSY SEE SH NO. 2

| | | | |
|--|----------|---|---|
| TOLERANCES UNLESS OTHERWISE SPECIFIED FRACTIONS DEC. ANGLES | | western peripherals ANAHEIM, CALIFORNIA | |
| ± | ± | ± | ASSEMBLY- ADAPTER TAPE CONTROL CONNECTOR |
| APPROVALS | DATE | SCALE | SIZE DRAWING NO. |
| DRAWN CORUM | 11-8-76 | FULL | B 122037 |
| CHECKED N.D. | 12-16-78 | | |
| DO NOT SCALE DRAWING | | | SHEET 1 OF 2 |

| | | | | |
|-----|---|-----|-----|----------|
| 0 | 3 | YEL | (A) | 122037-1 |
| 1 | 6 | RED | (B) | |
| 2 | 9 | GRN | (D) | |
| 3 | 2 | ORG | (C) | |
| COM | 1 | BRN | (L) | |

122037-1 WIRING DIAGRAM

ITEM NO.14
(9 PIN MOLEX PLUG, REF)

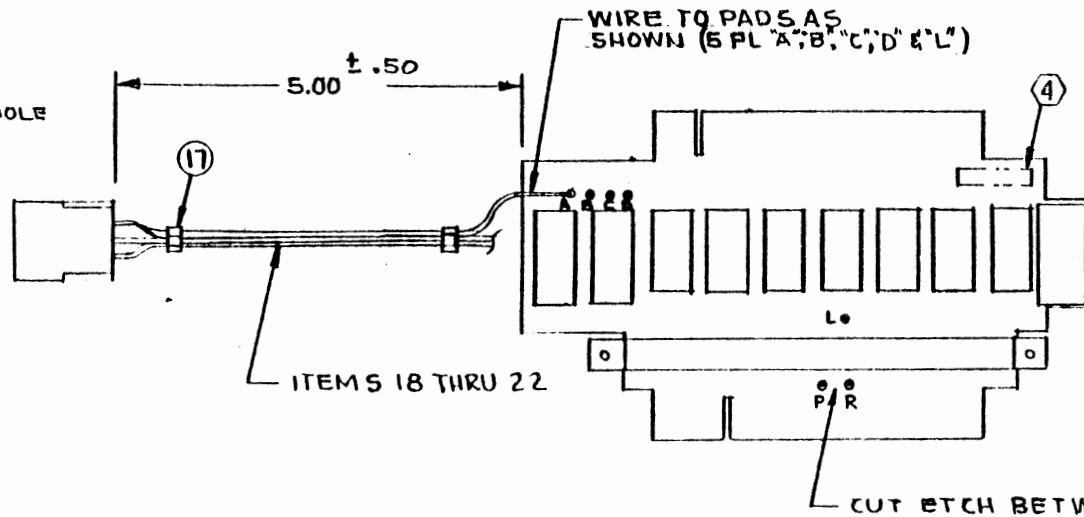
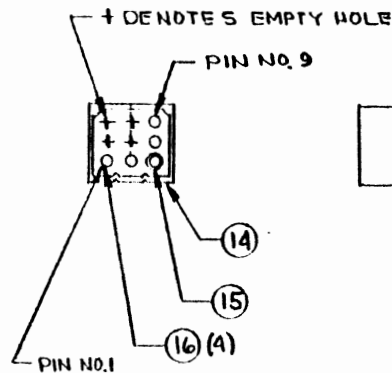

NOTE:

THE -1 ASSY IS USED ON PERTEC T9000 SERIES WITH OPTIONAL UNIT SELECT THUMBWHEEL SWITCH TERMINATED IN MOLEX CONNECTOR. COMPONENT REQUIREMENTS & MARKINGS ARE THE SAME AS FOR BASIC ASSY

-1 ASSY SHOWN
FOR BASIC ASSY SEE SH NO.1

| REVISIONS | | | |
|-----------|-------------|------|----------|
| LTR | DESCRIPTION | DATE | APPROVED |
| | | | |

| | | | |
|---------------------------------------|-------------|---|-------------|
| TOLERANCES UNLESS OTHERWISE SPECIFIED | | western peripherals ANALHEIM, CALIFORNIA | |
| FRACTIONS | DEC. ANGLES | | |
| ± | ± ± | ASSEMBLY - ADAPTER | |
| APPROVALS | DATE | TAPE CONTROL CONNECTOR | |
| DRAWN | 11-19-77 | SCALE | DRAWING NO. |
| CORUM | | FULL | B 122037 1 |
| CHECKED | | DO NOT SCALE DRAWING | |
| | | SHEET 2 OF 2 | |

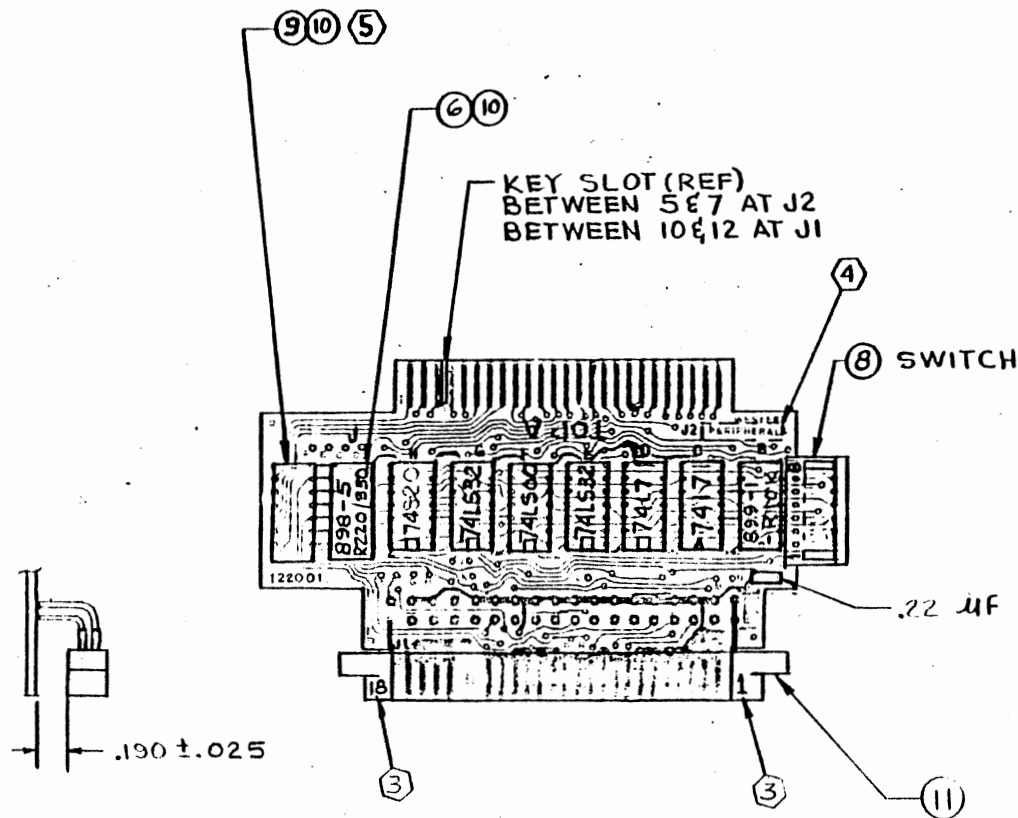

| REVISIONS | | | |
|-----------|---|----------|------------|
| LTR | DESCRIPTION | DATE | APPROVED |
| A | E.C.O. NO. - 0143 | 1-18-77 | |
| B | E.C.O. NO. - 0190 | 6-3-77 | J.D. 11-77 |
| C | E.C.O. NO. - 0197 | 8-8-77 | J.D. 8-77 |
| | E.C.O. NO. - 299 (NO REV. LTR. CHG.) | 3-8-78 | J.D. 3-78 |
| | ADDED NOTE 7. PER E.C.O. 257 AND DELETED REQUIREMENT FOR SLEEVING WIRE AT CONNECTOR | 3-21-78 | J.D. 3-78 |
| D | USE 'F' REV FWB, REF ECO No. 236A | 5-16-78 | J.D. 5-78 |
| E | REVISED NOTE 3 PER ECO 455 | 11-24-78 | J.D. 11-78 |
| F | DELETED NOTE 6 PER ECO 414 | 11-24-78 | J.D. 11-78 |
| G | CHANGED I.C. AT LOC H PER ECO 806 | 12-9-80 | J.D. 12-80 |
| H | INC ECO NO. 852 | 1-15-81 | J.D. 1-81 |

8. FOR CONFIGURATION "S" SEE DWG. 112001
 7. FOR CONFIGURATION "N" SEE DWG. 122044

6.
 5. FOR OPTIONAL JUMPERING AND/OR JUMPER ARRAYS, REF J.O.A. & SCHEMATIC
 4. RUBBER STAMP ASSY NO. WITH LATEST REV LTR LOCATED APPROX WHERE SHOWN (FAR SIDE)
 3. RUBBER STAMP CHARACTER SHOWN USING WHITE INK
 2. FOR MATERIAL SEE P/L NO. 122038
 1. REF SCHEMATIC 122036
 NOTE: UNLESS OTHERWISE SPECIFIED

177 27 1987

| TOLERANCES UNLESS OTHERWISE SPECIFIED | | FRACTIONS DEC. ANGLES | | western peripherals ANAHEIM, CALIFORNIA | |
|---------------------------------------|----------|-----------------------|------|---|--|
| ± | ± | ± | ± | ASSEMBLY- ADAPTER TAPE CONTROL CONNECTOR 90° MOUNTING | |
| APPROVALS | DATE | SCALE | SIZE | DRAWING NO. | |
| DRAWN CORLUM | 11-8-76 | FULL | B | 122038 | |
| CHECKED J.D. | 12-16-76 | DO NOT SCALE DRAWING | | SHEET 1 OF 1 | |

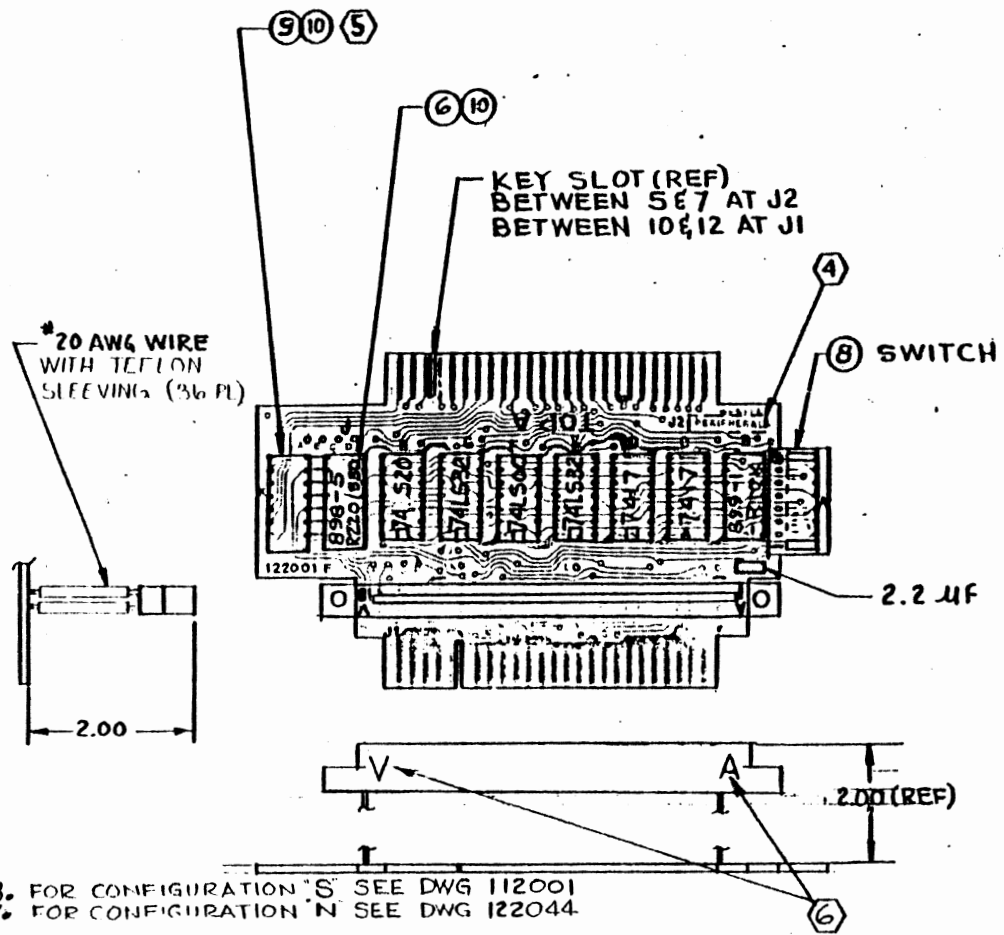

| REVISIONS | | | |
|-----------|-------------------------------------|----------|---------------|
| LTR | DESCRIPTION | DATE | APPROVED |
| A | E.C.O. NO.-0143 | 1-18-77 | |
| B | E.C.O. NO.-0190 | 6-5-77 | H.D. 11-77 |
| C | E.C.O. NO.-0197 | 8-8-77 | H.D. 8-9-77 |
| | E.C.O. NO-299 (NO REV. LTR. CHG.) | 3-8-78 | H.D. 3-5-78 |
| | ADDED NOTE 7. PER E.C.O. 257 | 3-21-78 | H.D. 3-21-78 |
| D | USE 'F' REV. PWB, REF. ECO No. 236A | 5-16-78 | H.D. 5-16-78 |
| E | DELETED NOTES 3 & 6 PER ECO #19 | 11-24-79 | H.D. 11-24-79 |
| F | ADDED NOTE (6) PER ECO # 504 | 6-20-77 | H.D. 6-20-77 |

G I.C. "H" S/B 74520 ELD 806

- 8. FOR CONFIGURATION "S" SEE DWG 112001
 - 7. FOR CONFIGURATION "N" SEE DWG 122044
 - 6. MARK CHARACTERS SHOWN (A&V) ON SIDE OF CONNECTOR USING CONTRASTING INK.
 - 5. FOR OPTIONAL JUMPERING AND/OR JUMPER ARRAYS, REF J.O.A. & SCHEMATIC
 - 4. RUBBER STAMP ASSY NO. WITH LATEST REV LTR LOCATED APPROX WHERE SHOWN (FAR SIDE)
 - 3.
 - 2. FOR MATERIAL SEE P/L NO. 122039
 - 1. REF SCHEMATIC 122036
- NOTE: UNLESS OTHERWISE SPECIFIED

| | | | |
|---------------------------------------|---------|--|---|
| TOLERANCES UNLESS OTHERWISE SPECIFIED | | western peripherals ANAHEIM, CALIFORNIA | |
| FRACTIONS | DEC. | | |
| ± | ± | ± | ASSEMBLY ADAPTER TAPE CONTROL CONNECTOR 2 INCH STAND OFF |
| APPROVALS | DATE | | |
| DRAWN CORD M | 11-8-76 | | |
| CHECKED V.D. | 12-8-76 | | |
| SCALE | | SIZE | DRAWING NO. |
| FULL | | B | 122039 |
| DO NOT SCALE DRAWING | | | SHEET 1 OF 1 |

| REVISIONS | | | |
|-----------|------------------------------------|------------------------|-------------|
| LTR | DESCRIPTION | DATE | APPROVED |
| A | REVISED NOTE 1 PER E.C.O. #355 | 2/2/79 | W.H. 2-9-79 |
| B | ADVANCED REV LTR TO AGREE WITH P/L | 2/2/79 | W.H. 2-9-79 |
| C | REVISED PER E.C.O. #417 | 2/2/79 | W.H. 2-9-79 |
| D | INC E.C.O. NO. 852 | MAR 3-17-81 3/24/81 | (K.P.) |

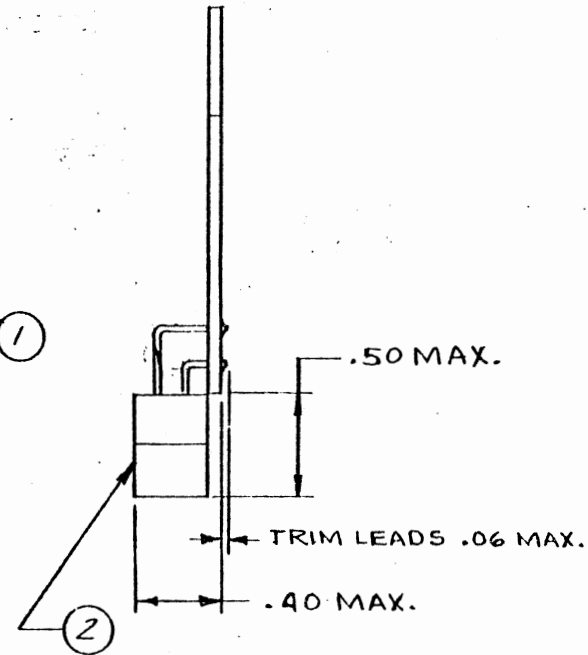
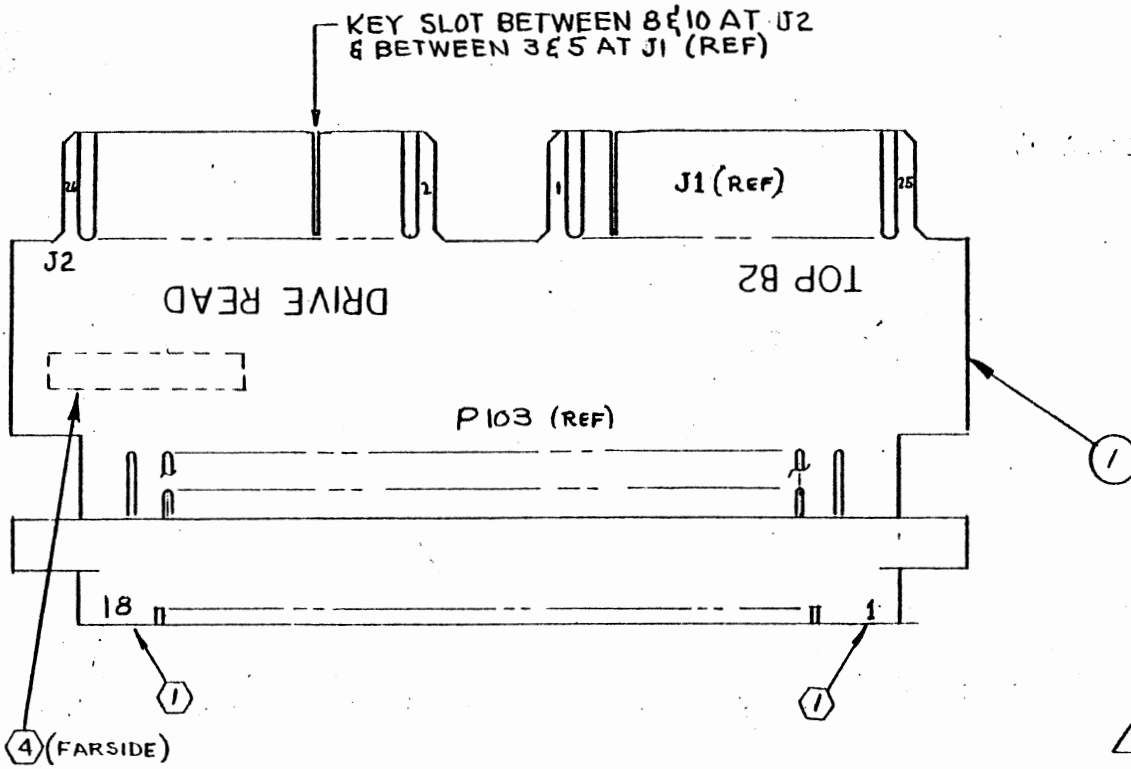

MAR 27 1981

- ④ RUBBER STAMP ASSY. NO. WITH LATEST REV LTR APPROX. WHERE SHOWN.
 3. SEE P/L 122043.
 2. REF. SCHEMATIC DWG NO. 122022.
 ① RUBBER STAMP CHARACTERS SHOWN WITH WHITE INK.

NOTE: UNLESS OTHERWISE SPECIFIED.

| | | | |
|---------------------------------------|---------|---|--|
| TOLERANCES UNLESS OTHERWISE SPECIFIED | | western peripherals ANAHEIM, CALIFORNIA | |
| FRACTIONS | DEC. | | |
| ± | ± | ± | ASSEMBLY-ADAPTER, TAPE READ, REVERSE IMAGE, 90° |
| APPROVALS | DATE | | |
| DRAWN <i>[Signature]</i> | 6/7/77 | | SCALE 2 X |
| CHECKED <i>[Signature]</i> | 6-11-77 | | |
| | | SIZE B | DRAWING NO. 122043 |
| DO NOT SCALE DRAWING | | | SHEET 1 OF 1 |

CONFIGURATION "N" CONTROL ADAPTER BOARD

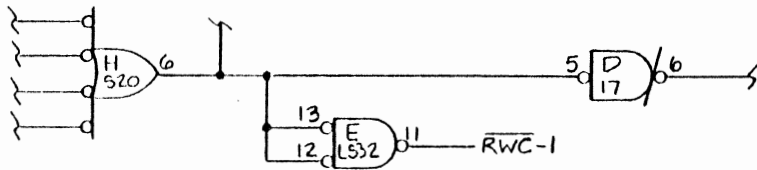

| | | |
|-------|----|-------|
| 1-RWS | C2 | 220PF |
| 1-BOT | C3 | 220PF |
| 1-OLS | C4 | 220PF |
| 1-EOT | C5 | 220PF |
| 1-HDS | C6 | 220PF |
| 1-RDY | C7 | 220PF |

| CAP. INSTALLATION CHART | | | |
|-------------------------|------|-----|------|
| CAP DESIG. | FROM | TO | TERM |
| C2 | D3 | GND | RWS |
| C3 | D11 | | BOT |
| C4 | F1 | | OLS |
| C5 | G1 | | EOT |
| C6 | F9 | | HDS |
| C7 | G13 | GND | RDY |

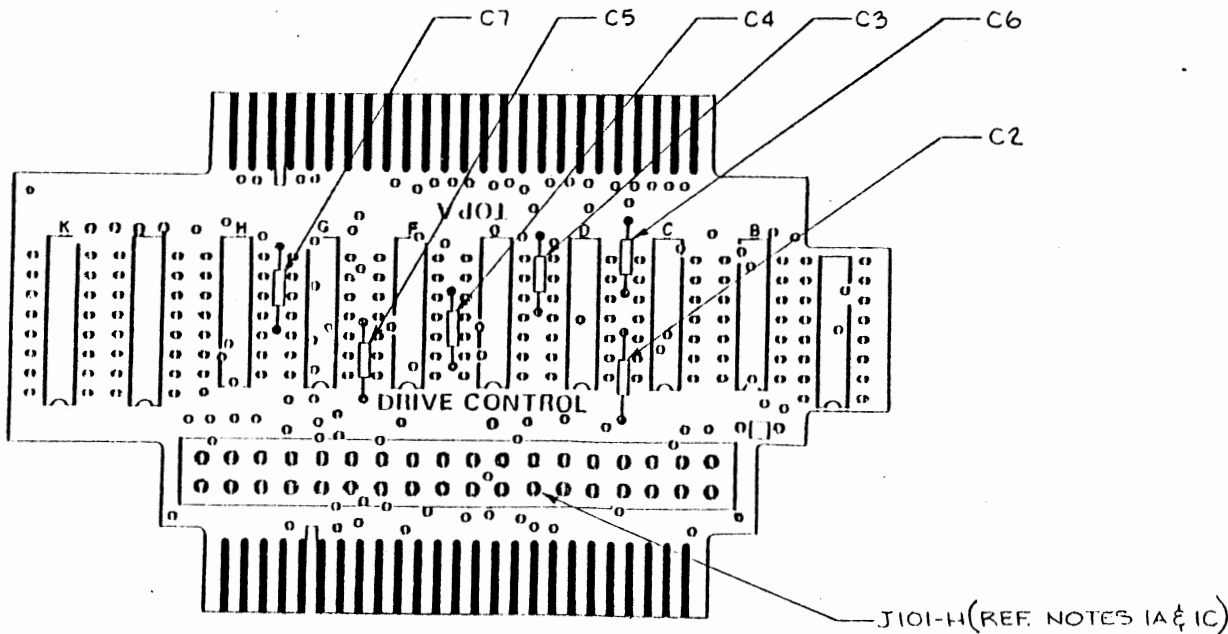

REVISIONS

| LTR | DESCRIPTION | DATE | APPROVED |
|-----|--|----------|--------------------|
| A | REDRAWN PER E.C.O. 237 | 10-27-77 | |
| B | REVISE PER E.C.O. 257 | 3-21-78 | |
| C | REVISE PER E.C.O. 236-A | 5-16-78 | |
| D | DELETE REWORK FOR "D" REV PWB PER E.C.O. 781 | 10-15-80 | <i>[Signature]</i> |
| E | CHANGED I.C. LOGIC PER E.C.O. 806 | 12-24-80 | <i>[Signature]</i> |

REWORK INSTRUCTIONS: (REF ASSY'S 122037, 122038 & 122039)

- MODIFY CIRCUIT
 - CUT ETCH (SOLDER SIDE) AT J101-H
 - JUMPER F5 TO E12 & I3 (SOLDER SIDE)
 - JUMPER E11 TO J101-H (SOLDER SIDE)
- COMPONENT ADDITION & MARKING
 - ADD (6) 220PF CAPACITORS (C2 THRU C7) AT LOCATIONS SHOWN
 - IDENTIFY AS "CONF N" AT ASSY NUMBER USING BLACK INK
- THIS MOD PROVIDES ISOLATION & FILTERING FOR ADAPTER ELECTRONICS
- MATERIAL REQUIREMENTS:
 - (1 REQ) BOARD ASSY AS NOTED IN PROCEDURES ABOVE
 - (6 REQ) 220PF CAPACITORS (WP15000195)
- VERIFY PROPER CAPACITOR INSTALLATION BY PERFORMING CONTINUITY CHECK PER THE CAPACITOR INSTALLATION CHART
- REF SCHEMATIC 122036
- APPLICABLE TO "F" (OR LATER) REV PWB ONLY. TO RETROFIT OLDER ASSEMBLIES WITH "D" REV PWB, REFER TO "C" REV HISTORY COPY OF THIS DRAWING

DEC 24 1980

| | | | |
|---------------------------------------|----------|--|------------------------------|
| TOLERANCES UNLESS OTHERWISE SPECIFIED | | western peripherals™ TUSTIN, CALIFORNIA | |
| FRACTIONS DEC | ANGLES | MODIFICATION DWG- TAPE CONTROL ADAPTER CONFIGURATION "N" | |
| ± ± ± | | SCALE | SIZE DRAWING NO. B 122044 |
| APPROVALS | DATE | DO NOT SCALE DRAWING | |
| DRAWN BY ANN L. STAN | 10-16-80 | SHEET 1 OF 1 | |
| CHECKED J. J. STAN | 12-24-80 | | |

| REVISIONS | | | |
|-----------|-----------------|---------|--------------------|
| LTR | DESCRIPTION | DATE | APPROVED |
| A | INITIAL RELEASE | 9-15-80 | <i>[Signature]</i> |

PURPOSE: TO PROVIDE START-UP AT 1600 B.P.I.

In order to initialize in the 1600 B.P.I. mode of operation, PROM's U45 and U56 in the upper-left corner of the Control Board must be of the proper type. A jumper must be installed.

1. The Prom Part Numbers can be 754013810 and 754013811 with revision levels of "G" or higher, or they may have part numbers beginning with 154 with any revision level.
2. A jumper must be installed between Pads "BP" and "BR" which are located below the PROMs and directly above U55.
3. After modification, install an adhesive label inside the front panel of the drive near the upper reel motor and Cipher label. The adhesive label should read: "Modified per Western Peripherals Configuration "A", Dwg. 79000410.

TAPE DRIVE MODIFICATION

SEP 15 1980

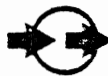
| | | | | |
|---------------------------------------|-------------|--|------------------|-------------------------|
| TOLERANCES UNLESS OTHERWISE SPECIFIED | |  western peripherals™ TUSTIN, CALIFORNIA | | |
| FRACTIONS | DEC. ANGLES | | | |
| ± | ± ± | | | |
| APPROVALS | DATE | MODIFICATION DRAWING - CIPHER 900X, CONFIGURATION "A" | | |
| DRAWN H. DEUTSCH | 9-15-80 | | | |
| CHECKED <i>D. Stubby</i> | 9-15-80 | SCALE | SIZE A | DRAWING NO. 79000410 |
| | | DO NOT SCALE DRAWING | | SHEET 1 OF 1 |

| REVISIONS | | | |
|-----------|-----------------|----------|----------|
| LTR | DESCRIPTION | DATE | APPROVED |
| A | INITIAL RELEASE | 12-30-80 | |

PURPOSE: TO ELIMINATE WRITE AND/OR READ ERRORS WHEN TAPE IS AT B.O.T. AND DRIVE IS OFF-LINE.

When Cipher 900X Tape Drives are received from vendor, they have the jumpers set in such a way that if the drive is off-line and at B.O.T., the computer receives a tape unit ready status and Write/Read errors are detected if the CPU attempts any Write/Read operation.

1. To prevent the above from happening, remove jumper BD to BC and install jumper BA to BB located in the vicinity of IC U52 on the Control/Servo PCB of the Cipher 900X type drive.
2. After modification, install an adhesive label inside the front panel of the drive near the upper reel motor and Cipher label. The adhesive label should read: Modified per Western Peripherals Configuration "B", Dwg. 79000642.
3. Reference Cipher Control/Servo Schematic 355012-300.

| | | | |
|---|----------|---|-------------------------|
| TOLERANCES UNLESS OTHERWISE SPECIFIED FRACTIONS DEC. ANGLES = = = | |  western peripherals ™ TUSTIN, CALIFORNIA | |
| APPROVALS | | MODIFICATION DRAWING - | |
| DATE | | CIPHER 900X, CONFIGURATION "B" | |
| DRAWN <i>H. D. [Signature]</i> | 12-30-80 | SCALE | SIZE |
| CHECKED <i>H. D. [Signature]</i> | 12-30-80 | | DRAWING NO. 79000642 |
| | | A | |
| DO NOT SCALE DRAWING | | | SHEET 1 of 1 |

NOTES

INSTALLATION CHECKLIST - CIPHER 100X

1. Open carton.
2. Turn over and lift off carton.
3. Remove corner pads.
4. Open inner carton.
5. Turn over and lift off carton from drive.
6. Locate manual and mounting hardware.
7. Inspect the drive - Contact the carrier if any concealed shipping damage is discovered.
8. On some cabinets, a mounting frame is required to mount the drive because the door swings against the edge of the cabinet. Mount the extender frame at the appropriate location in the cabinet. Be sure the hinge holes are on the correct side.
9. Refer to the tape drive manual.
10. Mount the tape drive hinges at an appropriate location on the cabinet. Place the longer hinge at the top. Place nylon washers on hinge pins.
11. Place drive on its back and remove screw from shipping frame.
12. Mount drive on hinges and secure with hinge safety block. Secure drive latch.

