

ORDER NO. MSD870909100

Service Manual

Flexible Disk Storage Drive

3.5 Inch

JU-253-T/JU-253-P/JU-253-PK

Panasonic

CONTENTS

	Page
PART 1	
1. INTRODUCTION	1
2. MODELS AND MODEL NUMBERS	1
3. SPECIAL TOOLS	1
4. OUTLINE OF MAINTENANCE	2
5. DIAGNOSTIC PROCEDURES	2
5.1 Error Symptom Recognition	2
5.2 Soft Error Detection and Correction	2
5.3 Write Error	2
5.4 Read Error	3
5.5 Seek Error	3
5.6 Interchangeability Error	3
6. TROUBLE ANALYSIS	3
6.1 Trouble Analysis Procedure	3
6.2 Trouble Shooting Flow Chart	4
6.3 Trouble Analysis Table	5
7. PREVENTIVE MAINTENANCE	6
8. MEASUREMENT ITEMS	6
9. ADJUSTMENTS AND VERIFICATIONS	7
9.1 Motor Speed Verification (Index Period)	7
9.2 Write Protect Verification	7
9.3 Head Output Verification	8
9.4 Output Modulation Verification	7
9.5 Resolution Verification	8
9.6 Radial Alignment Adjustment	8~9
9.7 Azimuth Verification	9~10
9.8 Index Burst Verification and Adjustment	10
9.9 Track 00 Sensor Adjustment	10~11
9.10 Asymmetry Verification	12
10. TEST POINT	13
11. PANASONIC ALIGNMENT DISKETTE	14
PART 2 [JU-253-T]	
12. DISASSEMBLY AND REASSEMBLY	15
12.1 Removing and Remounting the Cover	15
12.2 Removing and Remounting the Front Panel Assembly	15
12.3 Removing and Remounting the Guide Plates	15
12.4 Removing and Remounting the Holder Assembly and Rollers	15~16
12.5 Removing and Remounting the Head FPC, Track 0 Connector, and Stepper Motor Connector	16
12.6 Removing and Remounting the Head Carriage Assembly, Rod Clamp, and Guide Rod	16~17
12.7 Removing and Remounting the Track 0 Assembly	17
12.8 Removing and Remounting the Stepper Motor	17
12.9 Removing and Remounting the Trigger Lever Assembly	18
12.10 Removing and Remounting the Eject Lever Springs	18
12.11 Removing and Remounting the Eject Lever	18
12.12 Removing and Remounting the Shield Plate	19
12.13 Removing and Remounting the Microswitch Assembly	19
12.14 Removing and Remounting the Mounting Brackets	19
12.15 Removing and Remounting the Control PC Board	20
12.16 Removing and Remounting the Drive Motor Assembly	20
12.17 Disassembling and Reassembling the Mounting Bracket Assembly	20~21
12.18 Removing and Remounting the Pushbutton	21
12.19 Disassembling and Reassembling the Holder Assembly	21
12.20 Mounting the Drive Motor LED	21

	Page
[JU-253-P/-PK]	
12. DISASSEMBLY AND REASSEMBLY	22
12-1 Removing and Remounting the Cover	22
12.2 Removing and Remounting the Front Panel Assembly	22
12.3 Removing and Remounting the Holder Assembly and Rollers	22
12.4 Removing and Remounting the Head FPC, Track 0 Connector, and Stepper Motor Connector	22~23
12.5 Removing and Remounting the Head Carriage Assembly, Rod Clamp, and Guide Rod	23
12.6 Removing and Remounting the Track 0 Assembly.....	23~24
12.7 Removing and Remounting the Stepper Motor	24
12.8 Removing and Remounting the Trigger Lever Assembly.....	24
12.9 Removing and Remounting the Eject Lever Springs	25
12.10 Removing and Remounting the Eject Lever	25
12.11 Removing and Remounting the Microswitch Assembly.....	25~26
12.12 Removing and Remounting the Mounting Brackets	26
12.13 Removing and Remounting the Control PC Board	26
12.14 Removing and Remounting the Drive Motor Assembly	26~27
12.15 Disassembling and Reassembling the Mounting Bracket Assembly.....	27
12.16 Removing and Remounting the Pushbutton	27
12.17 Disassembling and Reassembling the Holder Assembly.....	27~28
12.18 Mounting the Drive Motor LED	28
13. EXPLODED VIEW 1-1 [JU-253-01T].....	29
EXPLODED VIEW 1-2 [JU-253-01T]	30
EXPLODED VIEW 2-1 [JU-253-01P/-01PK].....	31
EXPLODED VIEW 2-2 [JU-253-01P/-01PK].....	32
14. REPLACEMENT PARTS LIST 1-1 Model : JU-253-01T.....	33
REPLACEMENT PARTS LIST 1-2 Model : JU-253-01P.....	34
REPLACEMENT PARTS LIST 1-3 Model : JU-253-01PK.....	35
REPLACEMENT PARTS LIST OF PCB 2-1 Model : JU-253-01T/-01P.....	36~37
REPLACEMENT PARTS LIST OF PCB 2-2 Model : JU-253-01PK.....	38~39
15. SCHEMATIC DIAGRAM OF CONTROL BOARD [JU-253-01T/-01P]	40
SCHEMATIC DIAGRAM OF CONTROL BOARD [JU-253-01PK]	41
16. CIRCUIT BOARD [JU-253-01T/-01P]	42
CIRCUIT BOARD [JU-253-01PK]	43

PART. 1

1. INTRODUCTION

This service manual consists of two parts. Part 1 covers maintenance description, adjustment procedures, and trouble analysis and Part 2 covers disassembly and reassembly procedures, parts list, and PCB circuits. Refer to the highlighted applicable items, and perform maintenance work on the Floppy Disk Drive (FDD).

Note :

This service manual is prepared for maintenance of the Floppy Disk Drive.
Do not use this manual for judging pass or fail criteria in inspections.

2. MODELS AND MODEL NUMBERS

2.1 3.5-inch FDD Series

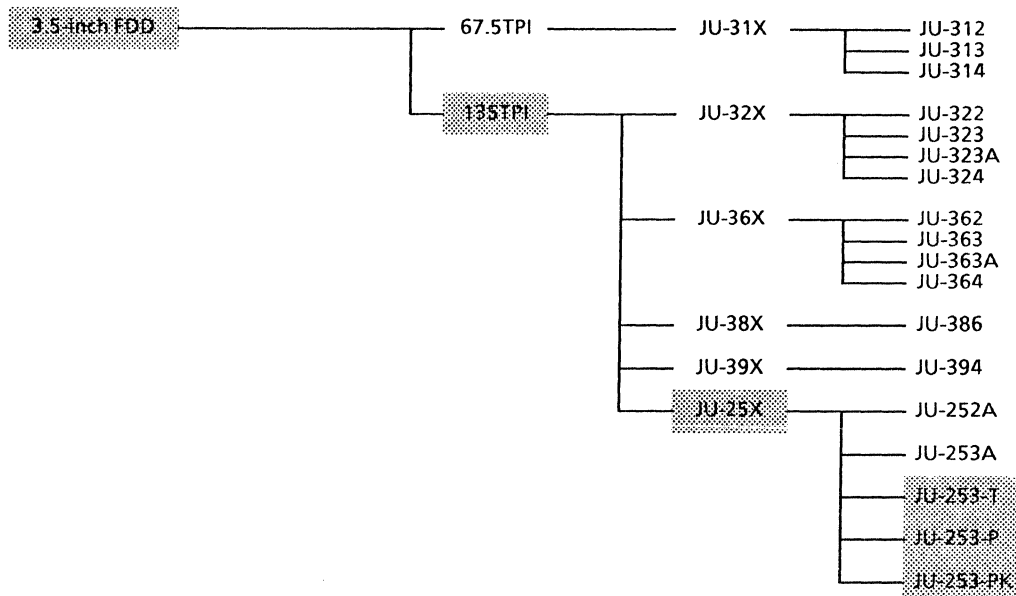

3. SPECIAL TOOLS

The following special tools are used for FDD maintenance.

TABLE 3.1

Tool	P / No.				Quantity
	JU-253-T/P/PK	JU-252A JU-253A	JU-31X,32X,36X, JU-323A,363A	JU-38X JU-39X	
Exerciser	YTFD-EXT-35	* ←	* ←	* ←	1
Alignment	DAD JU-01AA	* ←	* ←	817-384	1~2
Diskette	CE B17-363CE	* ←	* ←		
Data Diskette	2DD	* ←	* ←	2DD / 2HD	1~2
CMOS/TTL Adaptor	YTFDD-CN35	* ←	* ←	* ←	1
Step Motor and Head Assy Mounting Jig	NOT required	* ←	YTFDD-SB35	* ←	1
Test Pin Jig For PCB		YTFDD-TPIN25	YTFDD-TPIN35	* ←	1
DAD Alignment Tester	JU-02A	* ←	* ←	* ←	1
Oscilloscope (50MHz)					1
Probe (10:1)					3
Frequency Counter					1

Note: * ← : Stand for the same as left.
DAD : Dynamic Alignment Diskette
CE : Cats Eye

4. OUTLINE OF MAINTENANCE

•The following tools are required for maintenance of a Floppy Disk Drive.

4.1 Alignment Diskette

Alignment diskette is used for head actuator alignment and index sensor adjustment. Use the right diskette as shown in Table 3.1.

4.2 Exerciser

The exerciser enables you to make all adjustments and inspections necessary for an FDD. Its functions include the following:

- (1) Seek increment or alternate tracks
- (2) Read (but no data compare)
- (3) Write 1F or 2F (All 0's or 1's)
- (4) Recalibration to track 00

The exerciser has switches and indicators to execute a specified function.

5. DIAGNOSTIC PROCEDURES

5.1 Error Symptom Recognition

Errors that occur because of the wrong operating procedure, wrong programming, or use of a defective diskette, or soft errors due to external causes, such as contaminated air and random electrical noise, are often attributed to a drive failure.

Unless a visual inspection of the drive reveals an evident assembly fault or a defect, **always confirm errors with another good diskette, and another known good drive.**

5.2 Soft Error Detection and Correction

Soft errors are normally caused by the following:

- (1) Contamination between read/write heads and diskette. This kind of contamination can be easily eliminated by the liner in the diskette. Contaminated heads can be cleaned by a general purpose non-abrasive head cleaning diskette. Please follow the suitable procedure provided with the cleaning diskette.
- (2) Random electrical noise, normally a few microseconds or less.
- (3) Small defects in written data and/or track not detected during write operation may cause soft errors during read.
- (4) Faulty grounding of the drive or host system can also cause a soft error.
- (5) Wrong motor speed is another cause of soft errors.

Take the following steps on the controller side to recover from the soft errors mentioned above.

- (1) Read the track again ten times or until the data is recovered.
- (2) If Step (1) above fails to recover the data, access the adjacent track. Then return the head to the original track.
- (3) Repeat Step (1).
- (4) Any error that cannot be corrected by the above procedure is irrecoverable.

5.3 Write Error

If an error occurs during write operation, it is usually detected during the next revolution by performing a read operation called write check. To correct an error, write again and repeat a write check operation. If the result is unsatisfactory after ten or more write operations, perform a read operation on another track to determine whether it is the diskette or the drive that is wrong. If an error persists, replace the diskette and repeat the above procedure. If the error still persists, consider the drive defective. If the error is corrected, dispose of the diskette as defective.

5.4 Read Error

Most read errors are soft errors. Data can be recovered by following the recovery procedure mentioned in 5.2.

5.5 Seek Error

(1) Stepper motor or stepper motor drive circuit is faulty.

(2) **Faulty carriage**

There are two ways of seek error recovery. One is to recalibrate to track 00 , and seek back to the original track. The other is to read the ID field, check the track number on which the head is located, and move the head away from it. And read it again.

5.6 Interchangeability Error

Data which is written by one drive may not be read by another. This error is called a Interchange-ability error,which can be caused mostly by the following reason,which should be checked as follows.

(1) Head misalignment: Refer to Adjustments and Confirmation Item 9.6

(2) Head output too low: Refer to Adjustments and Confirmation Item 9.3

(3) Motor speed difference: Refer to Adjustments and Confirmation Item 9.1

(4) Format difference

6. TROUBLE ANALYSIS

FDD trouble may occur in any of the following nine forms.

(1) Index detection failure

(2) Not ready

(3) Track 0 undetectable

(4) No seek

(5) No write

(6) No read

(7) Read error

(8) IN USE LED won't light.

(9) Write protect undetectable

Check with the troubleshooting flowchart in 6.2

CAUTION:

Be sure to switch power off before removing an FDD or PCB from the operating system.

6.2 Trouble Shooting Flow Chart

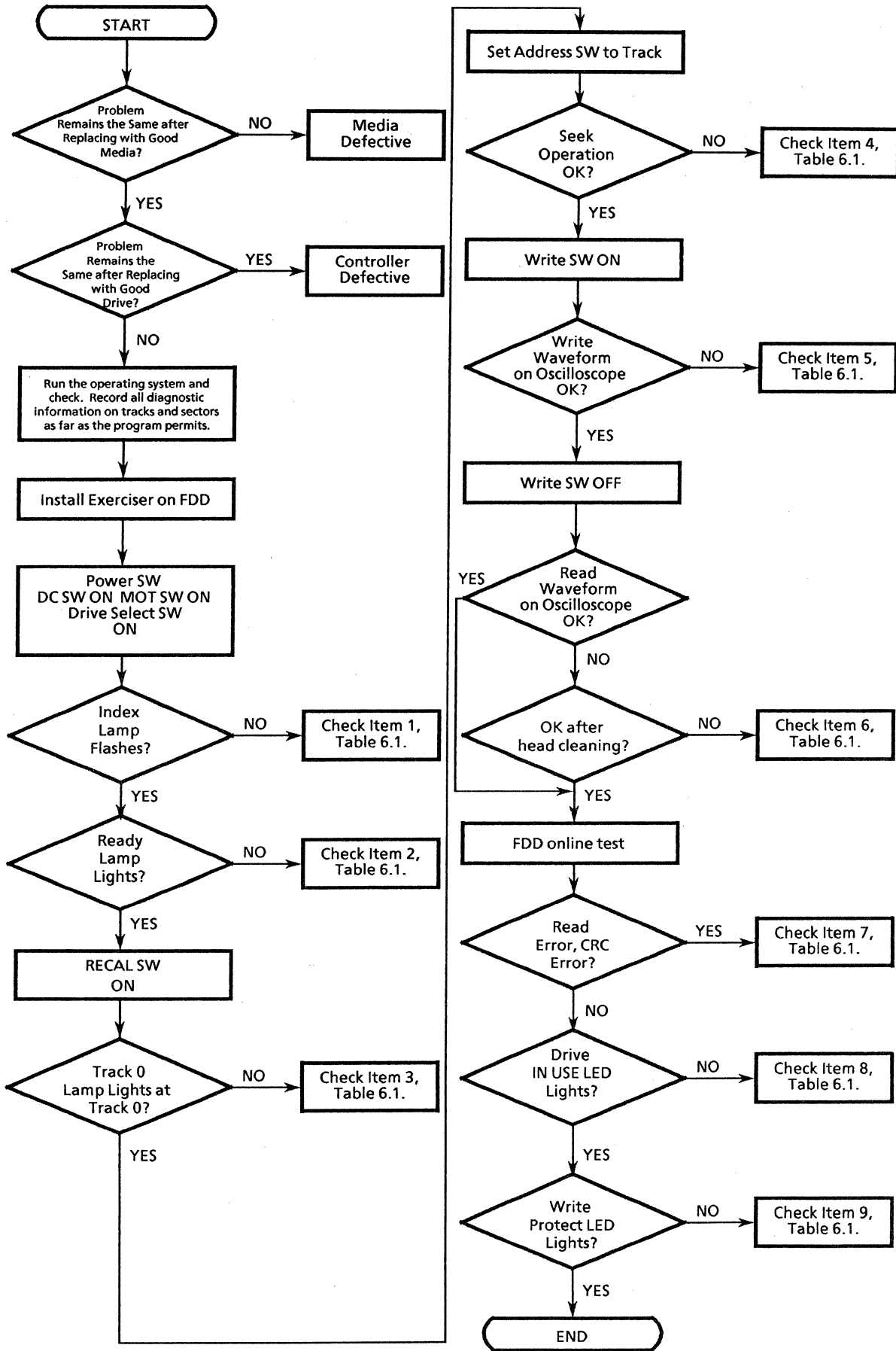

6.3 Trouble Analysis Table

Table 6.1

Item	Trouble	NO	Cause	JU-3X3, 3X4, 323A, 363A, 38X, 39X	JU-3X2, 252A, 253A, 253-T, 253-PJ-PK
1	Index detection failure	1	DD motor control PCB	Replace DD motor, Base assembly	Replace DD motor assembly
		2	DD motor faulty		
		3	Index LED faulty	Replace DD motor, Base assembly	Replace
		4	Index detector faulty		
		5	PCB motor ON circuit	Repair	* ←
		6	PCB index detection circuit	Repair	* ←
2	Not ready	1	See Item 1.		
		2	PCB ready circuit	Repair	* ←
3	Track 0 detection failure	1	Track 00 assembly	Replace	* ←
		2	PCB track 0 detection failure	Repair	* ←
4	No seek	1	Stepper motor	Replace	* ←
		2	Guide shaft contamination or damaged	Replace	* ←
		3	PCB stepper driver circuit	Repair	* ←
5	No WRITE	1	See Item 1.		
		2	Head disconnected	Replace	* ←
		3	Head shorted	Replace	* ←
		4	PCB write circuit	Repair	* ←
6	No READ	1	See Item 1.		
		2	See Item 5.		
		3	PCB read circuit	Repair	* ←
7	READ ERROR	1	See Item 1.		
		2	See Item 6.		
		3	Alignment	Adjustable.	* ←
		4	Azimuth	Unadjustable	* ←
		5	Burst	Unadjustable	* ←
		6	Asymmetry	Adjustable	* ←
		7	Limiter	Adjustable	* ←
		8	Flag 0	Adjustable	* ←
		9	Index period	Replace DD motor, Base assembly	Replace DD motor assembly
		10	PCB read circuit	Repair	* ←
8	IN USE LED won't light.	1	LED part	Repair	* ←
		2	PCB IN USE circuit	Repair	* ←
9	Write protect failure	1	Write protect part	Replace DD motor, Base assembly	Replace
		2	Write protect circuit	Repair	* ←

Note: * ←: Stand for the same as left.

7. PREVENTIVE MAINTENANCE

No preventive maintenance is necessary for any type of FDDs under normal conditions of use. However if it is determined that adjustments are necessary, the following must be done.

- **Adjustments (Refer to table 8.1)**

- (1) Make a read/write head radial adjustment at a specified track. (Sides 0,1)
- (2) Make an index timing adjustment at a specified track. (Sides 0,1)
- (3) Make an azimuth measurement at a specified track. (Sides 0,1)

CAUTION

Do not write when using alignment diskette. Check that write protect sensor is properly operating with a data diskette.

Note : Section 9 describes the adjustment procedures in detail.

8. MEASUREMENT ITEMS

Table 8.1

Item	Parameter	JU-252A, 253A		JU-253-T	
		TRK	Value	TRK	Value
1	Index period	40	200 ± 2 ms	40	200 ± 2 ms
2	Output level	79	80 mV or more	79	80 mV or more
3	Modulation	0, 79	20% or less	0, 79	20% or less
4	Resolution	79	55% or more	79	55% or more
5	Radial Alignment	40	± 25µm	40	± 25µm
	Reference (DAD)		(43% or more)		(43% or more)
	Reference (CE by 817-363CE)		(55% or more)		(55% or more)
6	Azimuth	40	± 24'	40	± 24'
7	Index burst	40	3 ± 1.7 ms	40	3.1 ± 0.4 ms
8	Flag 0	From track 0 to track 1 and back	TR00 (TR0 : Low, TR1 : High)	From track 0 to track 2 and back	1 : 1
9	Asymmetry	79	≤ 700 ns	79	≤ 700 ns

9. ADJUSTMENTS AND VERIFICATIONS

9.1 Motor Speed Verification (Index Period)

- (1) Insert a diskette, run the motor, and clamp. Refer to the index period column of Table 8.1 for the applicable model.
- (2) Step to the specified track.
- (3) Connect a frequency counter to the INDEX signal.
Index (No. 8 Pin of CMOS/TTL Adaptor)
- (4) Check that the frequency counter readings meet the specifications in the table.

9.2 Write Protect Verification

- (1) Check that the exerciser's write protect lamp goes on and off as a media is inserted and removed as specified in the table below.

Media with write protect hole open : ON (Write protected)
Media with write protect hole closed : OFF (Not write protected)

9.3 Head Output Verification

Use a new diskette if possible to identify head failure for this check.

- (1) Insert a good diskette.
- (2) Run the motor.
- (3) Step to the track specified in the output level column of Table 8.1.
- (4) Connect the oscilloscope probe as specified below.

CH1 : T1
CH2 : T2
EXT: Index (No. 8 Pin of CMOS/TTL Adaptor)

Invert channel 2 and select the Add mode.

Set vertical deflection to 10 mV/division and horizontal deflection to 20 ms/division.

- (5) Write 2F (all ones) on the entire circumference.
(In case of a double-sided FDD, repeat it on sides 0 and 1 using SIDE SELECT.)
- (6) Check that the average output level meets the specifications of Table 8.1.

$$V_{\text{average}} = \frac{V_{\text{max}} + V_{\text{min}}}{2}$$

If it does not meet the specifications, refer to Item 7 of the Trouble Analysis Table.

9.4 Output Modulation Verification

Modulation: M is calculated by the following formula.

$$M(\%) = \frac{V_{\text{max}} - V_{\text{min}}}{V_{\text{max}} + V_{\text{min}}} \times 100$$
 using the value obtained in 9.3, and check that the calculated value meets the specifications of Table 8.1.

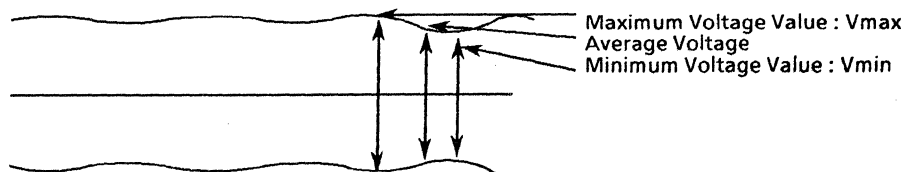

Fig. 9.1 Modulation

9.5 Resolution Verification

- (1) Leave the oscilloscope in the same condition as mentioned in section 9.3.
- (2) Resolution is calculated by the following formula.

$$\frac{V_{2F \text{ average}}}{V_{1F \text{ average}}} \times 100 (\%)$$

- (3) Check that the calculated value meets the specifications of Table 8.1.

9.6 Radial Alignment Adjustment

Introduction

This adjustment is normally not necessary.

If the mounting screws for the stepper motor loosen, or if parts become defective, or if a compatibility error occurs, check and readjust according to the following procedure.

Steps (4) to (9) below should be performed regardless of the type, CE or DAD alignment diskette used. Use an alignment diskette suitable to the type of FDD to be adjusted according to table 3.1.

- (1) Insert Panasonic alignment diskette.

CAUTION:

Be sure to leave the alignment diskette under room conditions for 20 minutes before adjustment.

- (2) Step to the track specified in the Radial alignment column of Table 8.1.
- (3) Leave the oscilloscope in the same condition as mentioned in section 9.3.

• Cats Eye System

- (4) Check the output waveforms for sides 0 and 1. They should appear as in Fig. 9.2.
- (5) The two waveforms should appear in the amplitude ratio in the R/A $\pm 55\%$ or more.
- (6) If the specified ratio is not satisfied, loosen the two mounting screws for the stepper motor.
- (7) Move the stepper motor along the base by hand until the two waveforms assume approximately the same amplitude, and retighten the mounting screws. (See Fig. 9.2.)
- (8) Step the head outward (track 0) and inward (track 40 or 79), and confirm that the adjustment has been completed.
- (9) After the radial adjustment, be sure to confirm track 00 sensor adjustment 9.9

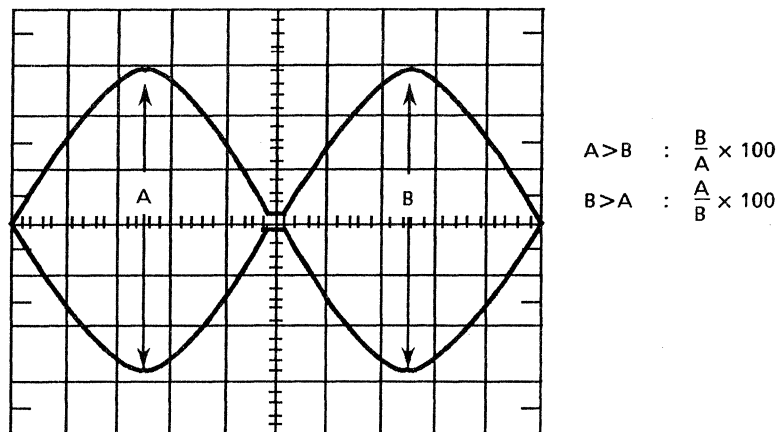

Fig. 9.2 Radial Alignment Waveforms (CATS EYE)

Note: Alignments on sides 0 and 1 are adjusted at the factory. If they are misaligned, adjust them to meet the specifications of Table 8.1.

- **DAD (Dynamic Alignment Diskette)**

- (4) Watch the output waveforms for sides 0 and 1. They should appear as shown in Fig. 9.3.
- (5) Measure the timing levels A₁ to A₄ and B₁ to B₄ in Fig. 9.3, and calculate the lobe ratio from the following formulas.

$$\Sigma A > \Sigma B : \frac{\Sigma B}{\Sigma A} \times 100\%$$

$$\Sigma A < \Sigma B : \frac{\Sigma A}{\Sigma B} \times 100\%$$

- (6) The lobe ratio calculated by the above formulas should meet the specifications on item 3 of Table 8.1.
- (7) If the above requirement is not met, loosen the two mounting screws for the stepper motor, adjust.
- (8) Seek from track 0 to track 40 and from track 79 to track 40, and confirm that the adjustment has been completed.
- (9) After the radial adjustment, be sure to confirm track 00 sensor adjustment 9.9.

Note: A digital alignment test instrument for 3.5-inch FDDs permits accurate and easy adjustment because the lobe ratio is displayed on the instrument.

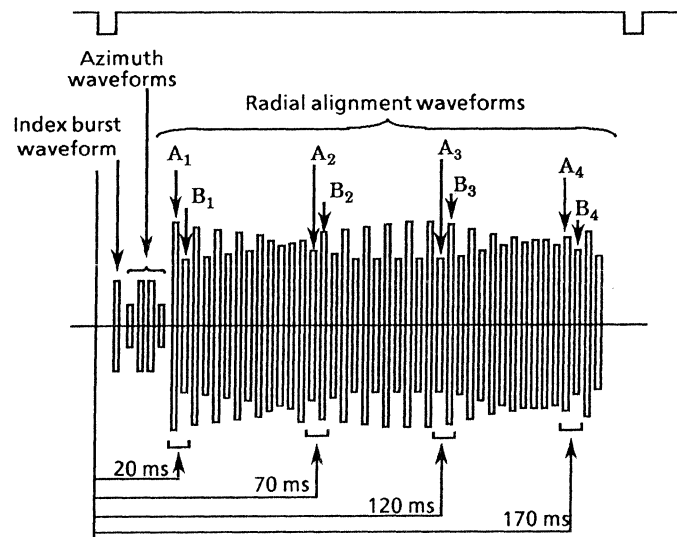

Fig. 9.3 Alignment Waveform (DAD)

9.7 Azimuth Verification

- (1) Insert an alignment diskette. Seek to the track specified in the azimuth column of Table 8.1.
- (2) Set the oscilloscope in the same conditions as in 9.3, and set horizontal deflection to 2ms/div (DAD) or 0.5 ms/div (CE).
- (3) Measure as shown below.
- (4) Confirm that the measured value meets the specifications in the azimuth column of Table 8.1.

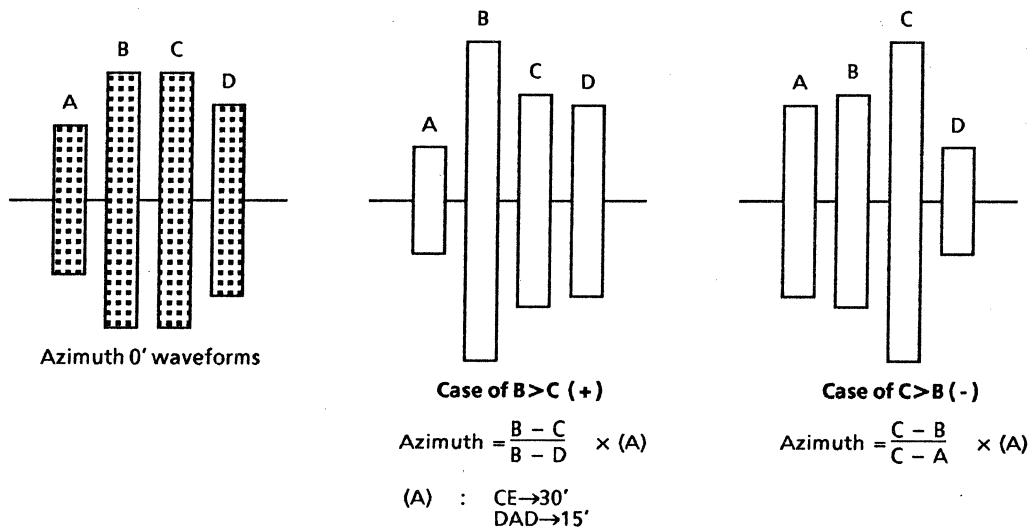

Fig. 9.4 Azimuth Waveforms

9.8 Index Burst Verification and Adjustment

- (1) Insert an alignment diskette. Seek to the track specified in the I/B column of Table 8.1.
- (2) Set the oscilloscope time base as follows:
1 ms/division
- (3) Check that the time from oscilloscope start to the first data pulse meets the I/B specifications of Table 8.1. (DAD system)
- (4) If Index Burst is not within specification, adjust the variable resistor on the motor control PCB.

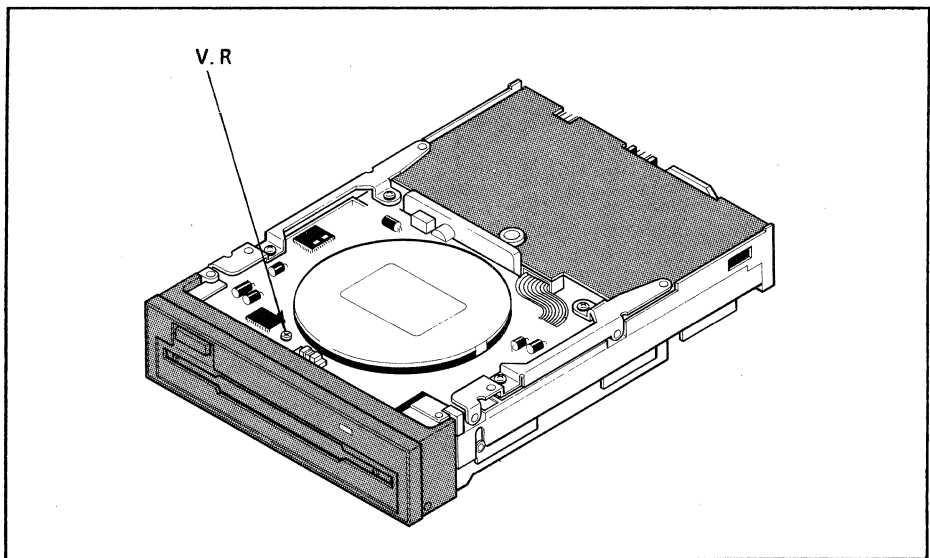
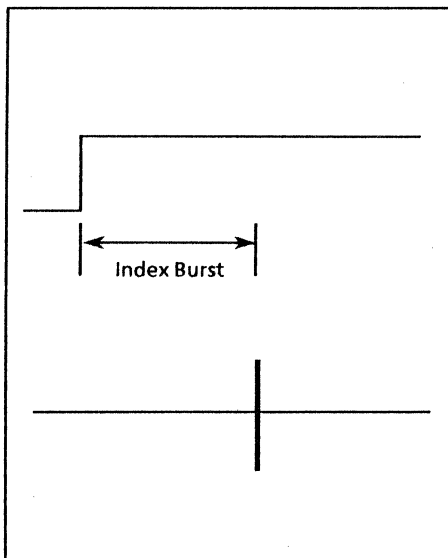

Fig. 9.5 Index Timing

Fig. 9.6 I/B Adjustment

9.9 Track 00 Sensor Adjustment

[In the case of JU-252A/JU-253A]

- (1) Set the oscilloscope as follows.
Set horizontal deflection to 1ms/division.

CH1 : ZP
EXT : SP

- (2) Step between specified tracks as shown in the FLAG 0 item of Table 8.1 (Turn the seek delay switch on the exerciser to adjust 12 ms seek.)
- (3) Loosen the track 0 sensor screw and adjust until the waveform on the oscilloscope appears as shown in Fig. 9.7.

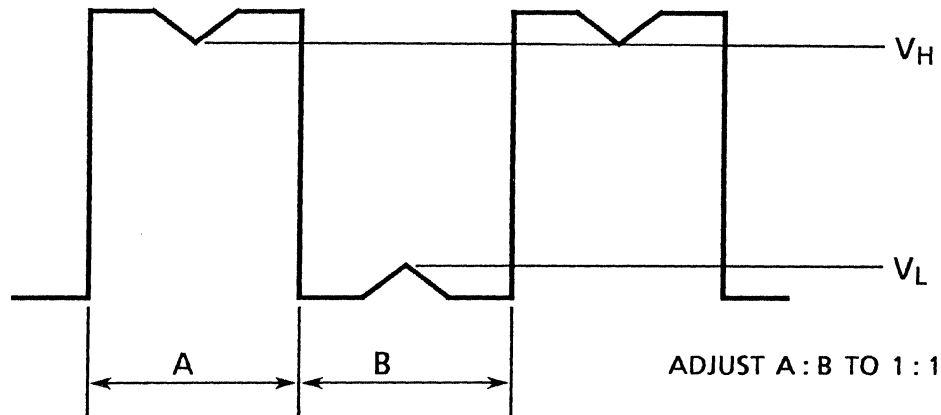

Fig. 9.7 Track 0 Waveform

[In the case of JU - 253 - T/P/PK]

- [1] Set the oscilloscope as follows.

Set horizontal deflection to 1ms/division.

CH1 : ZP

EXT : Step (No. 20 Pin of CMOS/TTL Adaptor)

- (2) Step between specified tracks as shown in the FLAG0 item of Table 8.1, (Turn the seek delay switch on the exerciser to adjust 3 ms seek.)
- (3) Loosen the screw for track 0 assembly so that the waveform on the oscilloscope is as shown in Figure 9.8 and adjust the track 0 assembly position by moving it back and forth.

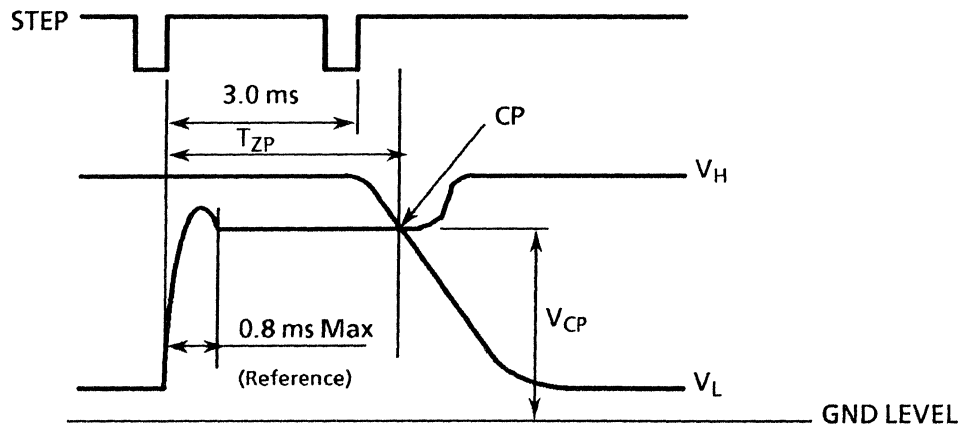

Fig. 9.8 Track 0 Waveform

- (4) Voltages/Timings for track 0 waveform

1. T_{ZP}	4.2ms
2. V_L	$\cong 1.0 \text{ V}$
3. V_H	$\cong 4.0 \text{ V}$
4. V_{CP}	$\cong 3.2 \text{ V}$

(5) After performing adjustment on items 1 to 4, reconfirm the following :

- ① Recalibrate to track \emptyset
- ② Step in for 40 steps.
- ③ Check the alignment waveform.

9.10 Asymmetry Verification

- (1) Insert a data diskette.
- (2) Step to the track specified in the Asymmetry item of Table 8.1.
- (3) Set the oscilloscope as follows:

CH1 : Read Data (No. 30 Pin of CMOS/TTL Adaptor)
CH2 : T1

Set time base to $1\mu\text{s}/\text{division}$ and vertical deflection to $0.2\text{ v}/\text{division}$.

- (4) Write 1F.
- (5) A read wave form is displayed on the oscilloscope as shown in Fig. 9.9.
- (6) Confirm if it satisfies the value as shown in Table 8.1.

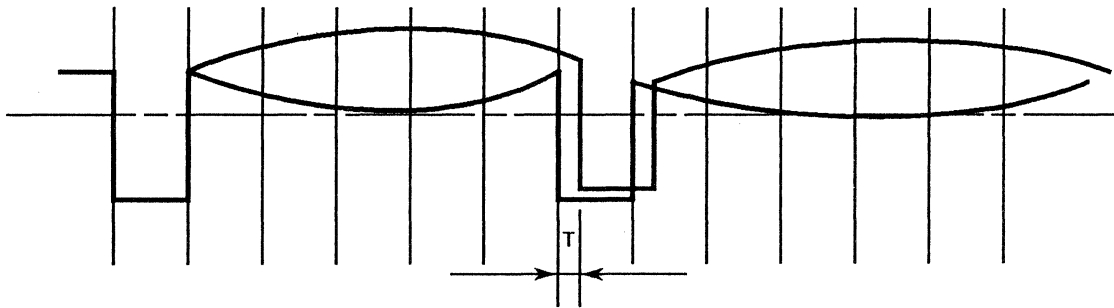
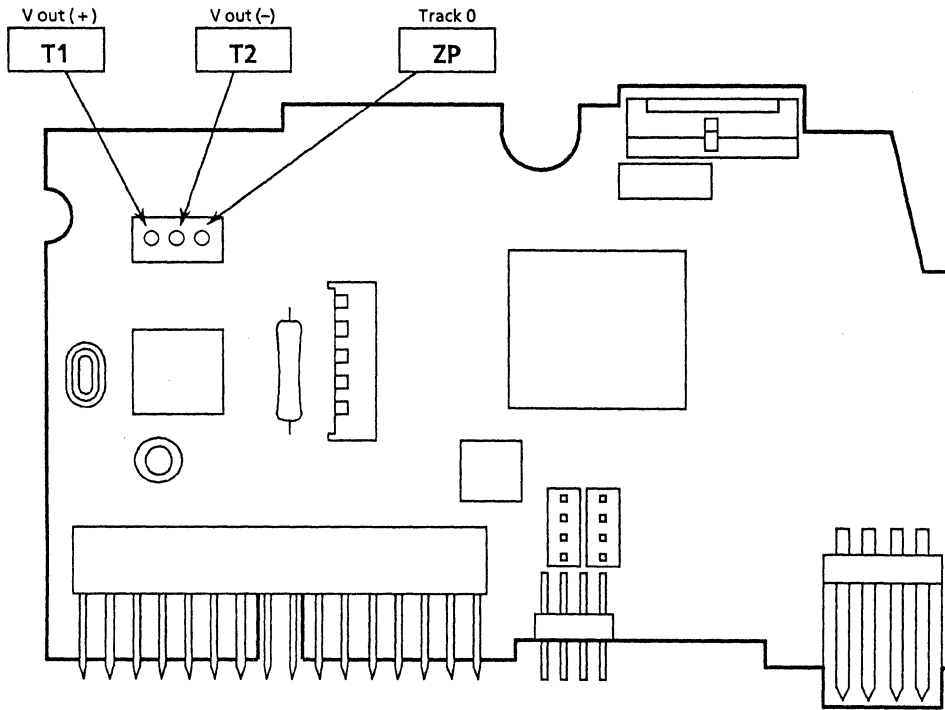

Fig. 9.9 Asymmetry Waveform

(Asymmetry Wave form might be reversed up-and-down from model to model.)

10. TEST POINTS



Component Side

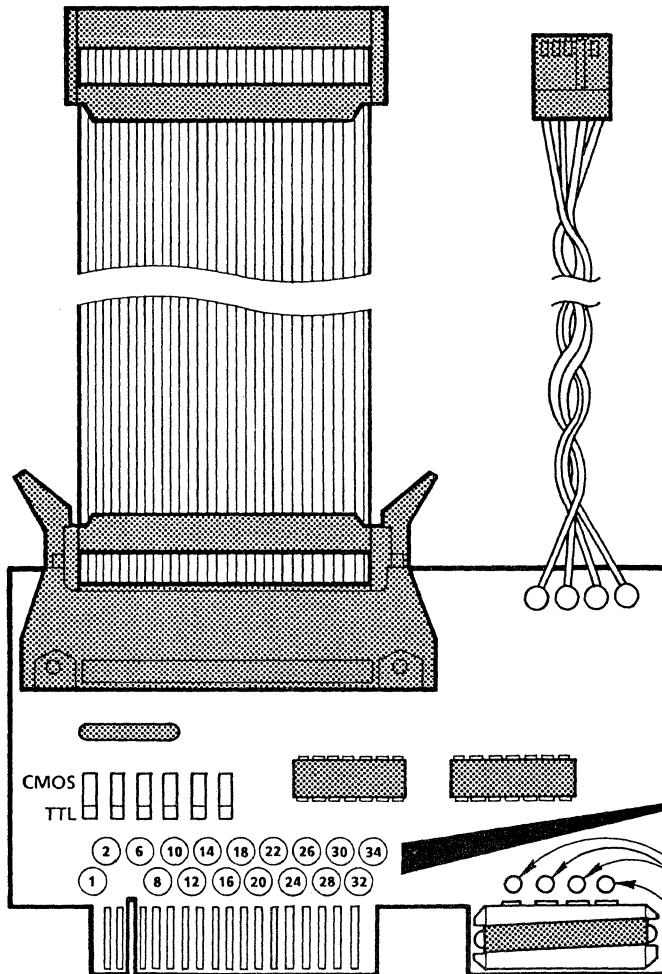

CMOS / TTL Adaptor [YTFDD - CN35]

Pin No.	Signal
1	NC (Disk Change Reset)
2	Disk Change (Disk In)
6	Drive Select 3
8	Index
10	Drive Select 0
12	Drive Select 1
14	Drive Select 2
16	Motor On
18	Direction Select
20	Step
22	Write Data
24	Write Gate
26	Track 00
28	Write Protect
30	Read Data
32	Side Select
34	Ready (Disk In/Disk-change)

11. PANASONIC ALIGNMENT DISKETTE

3.5 inch Alignment Diskette

Table 11.1

TPI	TYP of Alignment Diskette	P/N		Index Burst	Azimuth	Radial Alignment	MODEL
67.5	DAD	JU-01AA		20TRK	20TRK	20TRK	JU-31X
	CE	817-363CE					
135	DAD	JU-01AA		40TRK	40TRK	40TRK	JU-32X JU-36X JU-323A JU-363A JU-252A JU-253A JU-253-T JU-253-P/PK
	CE	817-363CE					
135	DAD	817-384		40TRK	40TRK	40TRK	JU-38X JU-39X

PART. 2 [JU-253-T]

12. DISASSEMBLY AND REASSEMBLY

12.1 Removing and Remounting the Cover

- (1) Remove the claws in the four corners of the cover from the base and guide plate and remove the cover.
- (2) To remount the cover, clutch the claws in the four corners of the cover from the outside.

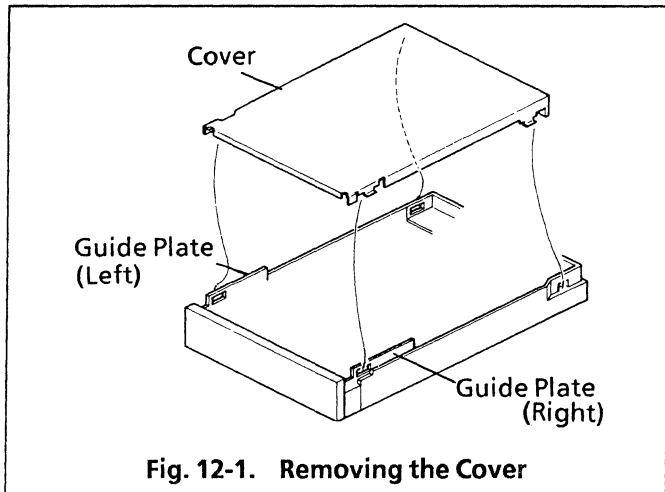

12.2 Removing and Remounting the Front Panel Assembly

- (1) Remove the two claws on the left side of the front panel from the left side guide plate, remove the two claws on the right side from the right side guide plate and remove the front panel.
- (2) Remount the front panel in the reverse procedure of step (1) so that the button is inserted into the button hole in the front panel.

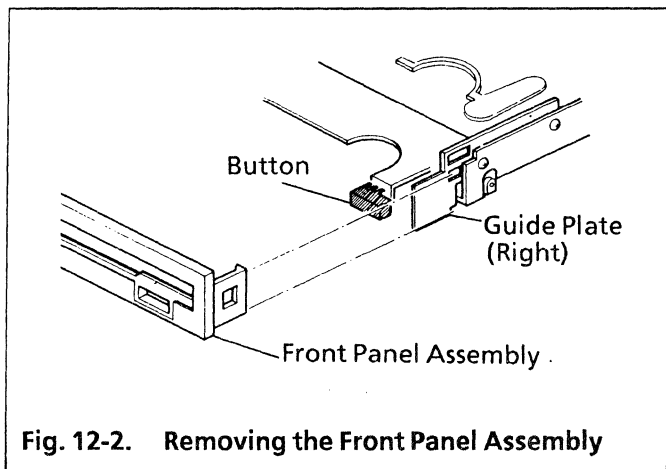

12.3 Removing and Remounting the Guide Plates

- (1) Remove the cover and front panel according to the procedures in sections 12.1 and 12.2.
- (2) Remove two set screws on the right side guide plate.
- (3) Lift the right side guide plate so that it is removed from the roller pinched by the recess in the guide plate and remove the right side guide plate through the path between the eject lever and the base.
- (4) Remove the left side guide plate in the same manner as above.
- (5) Remount both plates in the reverse procedure of steps (1) to (4).

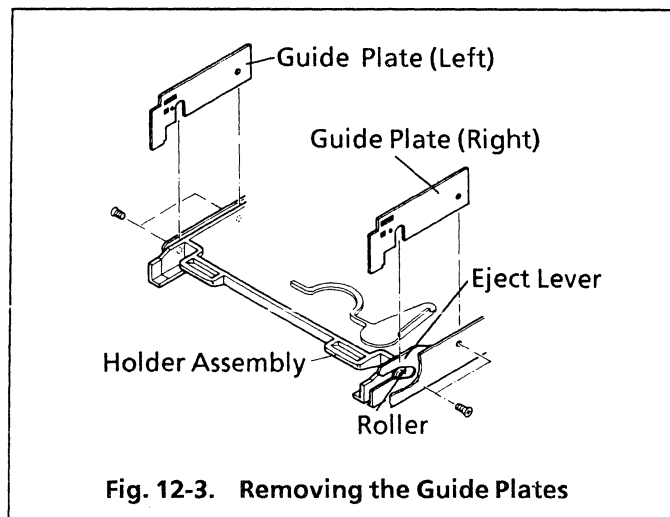

12.4 Removing and Remounting the Holder Assembly and Rollers

- (1) Remove the guide plates according to the procedure in section 12.3.
- (2) Lift the holder assembly by hands and gently slide it toward you, then the four roller sections on the holder will be removed from the eject levers. (Keep in mind that the rollers drop easily.) In this case, when the side 1 of the head assembly drops from the holder, it strikes the head on the side 0 being pushed by the side 1 head retaining spring, so lift it lightly by the thumb.
- (3) Remove the four rollers from the holder assembly.
- (4) Remount the rollers and holder assembly in the reverse procedure of steps (1) to (3).

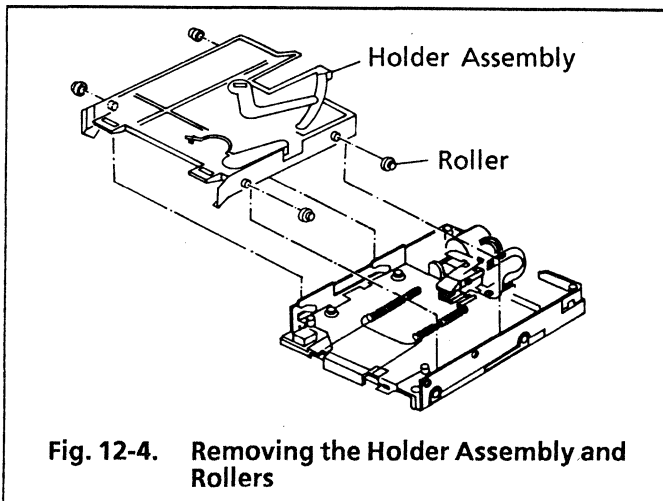

Fig. 12-4. Removing the Holder Assembly and Rollers

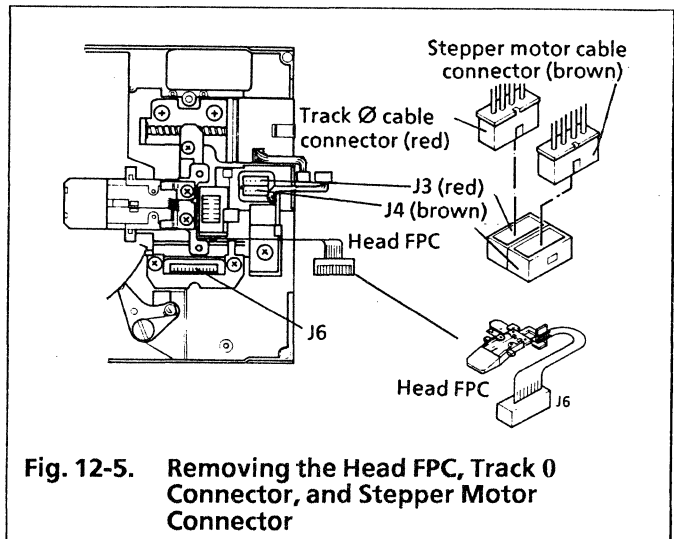

Fig. 12-5. Removing the Head FPC, Track 0 Connector, and Stepper Motor Connector

12.5 Removing and Remounting the Head FPC, Track 0 Connector, and Stepper Motor Connector

- (1) Draw the contact section of the head FPC upwards out of the head connector J6 by pinching it by flat pens with care not to damage it.
- (2) Remove the track 0 cable connector (red) from the connector J3 (on the stepper motor side, red) on the PCB.
- (3) Remove the stepper motor cable connector (brown) from the connector J4 (on the track 0 side, brown).
- (4) Remount the above in the reverse procedure of steps (1) to (3).
In this case, be sure to insert the head FPC to the full extent in the right angle. Wiring should be made so that the lead wire of the track 0 and the stepper motor does not contact the carriage of the head or hang over the track 0.
- (5) Ensure that the head FPC is not higher than the track 0 assembly.
- (6) Ensure that the head FPC does not contact the head of the track 0 assembly set screw.
Note: FPC: Flexible printed circuit.

12.6 Removing and Remounting the Head Carriage Assembly, Rod Clamp, and Guide Rod

- (1) Remove the holder assembly according to the procedure in section 12.4.
 - (2) Remove the head FPC from the connector J6 according to the procedure in section 12.5.
 - (3) Remove two set screws on the rod and remove the rod clamp.
 - (4) Move the head carriage assembly in the reverse direction of the stepper motor (rightward) and remove it.
 - (5) Draw the guide rod out of the head carriage assembly.
 - (6) Remount the above in the reverse procedure of steps (1) to (5).
- [Cautions for Remounting]**
- (7) Apply oil to the guide rod (but not too much), insert the rod into the head assembly, move it back and forth several times, and confirm that the guide rod moves smoothly.
 - (8) Place the position where the head carriage assembly pinches the stepper motor lead screw at the center of the lead screw length.
 - (9) Place the mounting position of the guide rod on the base so that the tail end of the guide rod comes to the same position as the base or projected less than 1 mm.

- (10) After remounting the above, adjust the radial alignment according to the procedure in section 9.6, adjust the track 00 sensor according to the procedure in section 9.9.

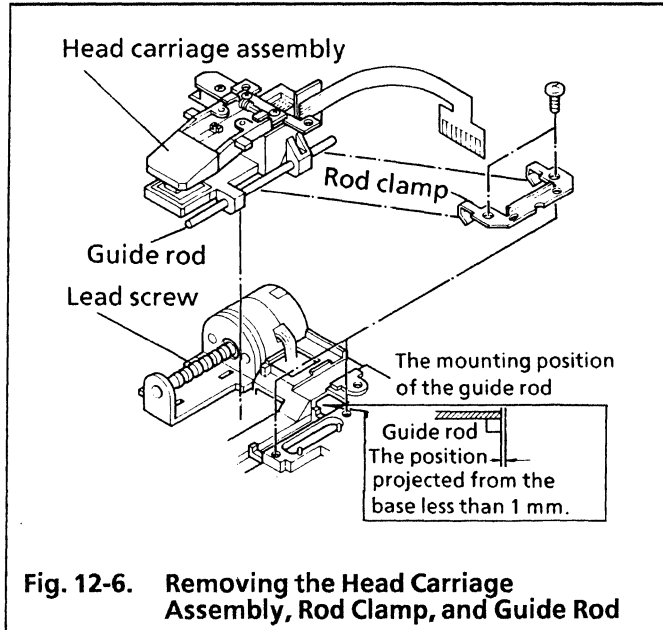

Fig. 12-6. Removing the Head Carriage Assembly, Rod Clamp, and Guide Rod

12.7 Removing and Remounting the Track 0 Assembly

- (1) Remove the cover according to the procedure in section 12.1.
- (2) Remove the track 0 cable connector according to the procedure in section 12.5.
- (3) Remove the set screw on the track 0 assembly and remove the track 0 assembly.
- (4) Remount the track 0 assembly in the reverse procedure of steps (1) to (3).
- (5) After remounting track 0 assembly, adjust the track 00 sensor according to the procedure in 9.9.

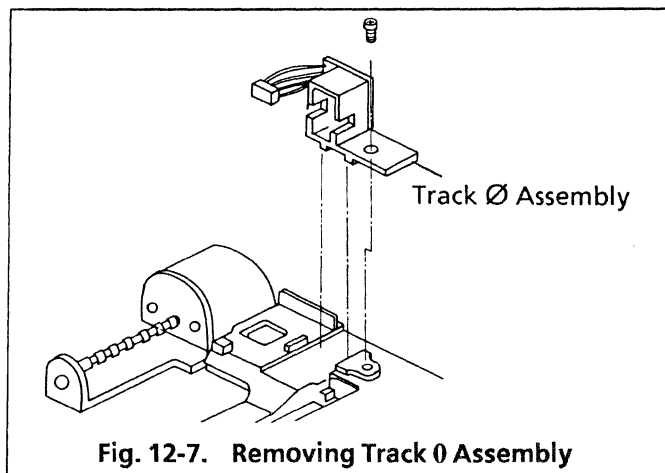

Fig. 12-7. Removing Track 0 Assembly

12.8 Removing and Remounting the Stepper Motor

- (1) Remove the cover according to the procedure in section 12.1.
- (2) Remove the stepper motor cable connector according to the procedure in section 12.5.
- (3) Remove the two set screws on the stepper motor and remove the stepper motor.
- (4) Remount the stepper motor in the reverse procedure of steps (1) to (30).
- (5) Ensure that the temporary fastened position of the stepper motor is placed so that the two projections on the base come to the centers of the two long holes in the stepper motor respectively.
- (6) Apply* grease to the lead screw of the stepper motor according to the procedures in steps (7) and (8).
- (7) Put grease in the size of a grain of rice on the lead screw.
- (8) Extend the grease over the lead screw evenly using an applicator.
- (9) After remounting the stepper motor, adjust the radial alignment according to the procedure in section 9.6, adjust the track 00 sensor according to the procedure in section 9.9.

Note: Grease: MOLYKOTE EM-30L manufactured by DOWCORNING.

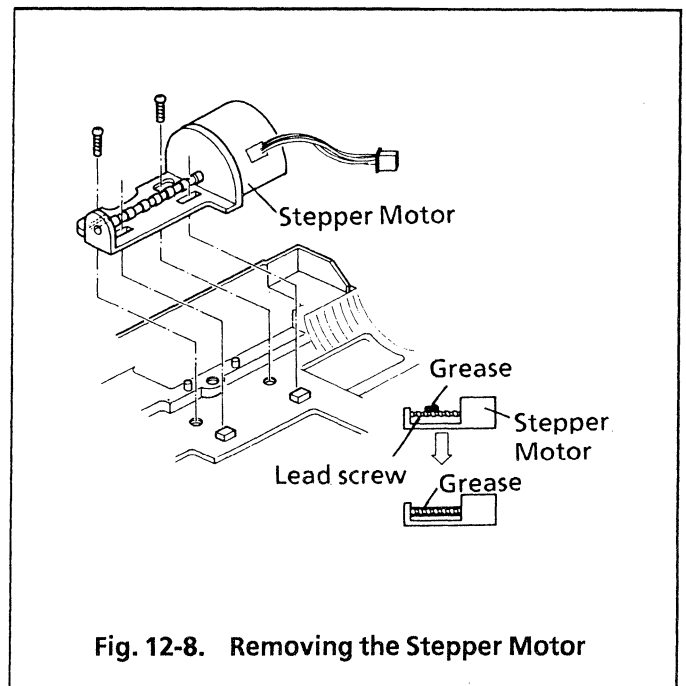

Fig. 12-8. Removing the Stepper Motor

12.9 Removing and Remounting the Trigger Lever Assembly

- (1) Remove the cover according to the procedure in section 12.1.
- (2) Remove the trigger lever set screws and remove the trigger lever spring and trigger lever assembly.
- (3) Remount the above in the reverse procedure of steps (1) and (2).

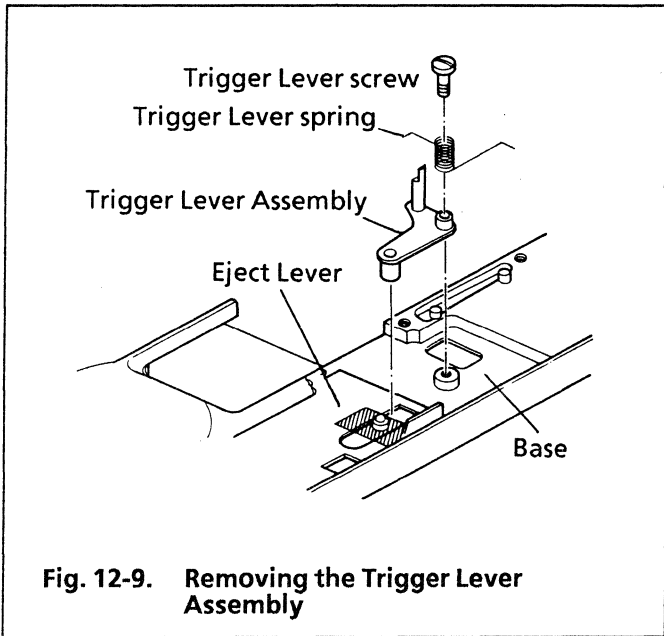

Fig. 12-9. Removing the Trigger Lever Assembly

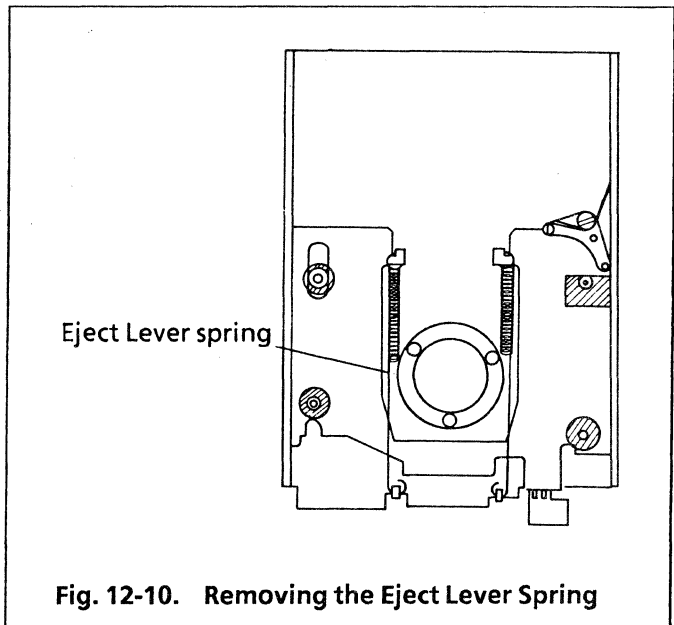

Fig. 12-10. Removing the Eject Lever Spring

12.11 Removing and Remounting the Eject Lever

- (1) Remove the eject lever springs according to the procedure in section 12.10.
- (2) Remove the trigger lever assembly according to the procedure in section 12.9.
- (3) Remove the four stopper rings and washers from the eject lever. Each stopper ring has a slit, so it can be easily removed by pinching the portion adjacent to the slit by tweezers.
- (4) Remove the eject lever.
- (5) Remount the eject lever in the reverse procedure of steps (1) to (4).

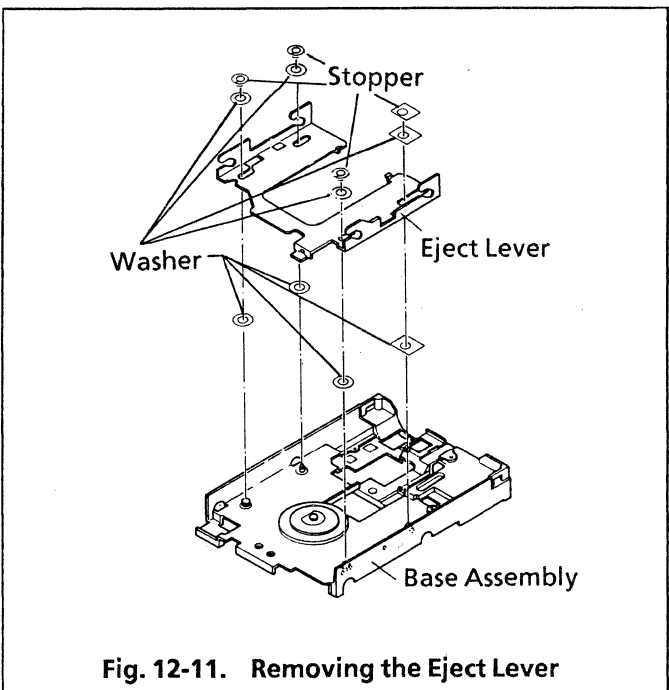

Fig. 12-11. Removing the Eject Lever

12.10 Removing and Remounting the Eject Lever Springs

- (1) Remove the holder assembly according to the procedure in section 12.4.
- (2) Remove the hook of the eject lever spring and remove the eject lever spring.
- (3) Remount the eject lever spring in the reverse procedure of steps (1) and (2).

[Cautions for Remounting]

- (4) Remount the front hooks on the base so that both of them on the right and left sides are faced inward.
- (5) Place the eject lever springs so that their coiled portions are faced rearward.

12.12 Removing and Remounting the Shield Plate

- (1) Remove the head carriage assembly according to the procedure in section 12.6.
- (2) The shield plate is attached to the back of the D motor PC board with gum tape, so remove it as it is.
- (3) Remount the shield plate in the reverse procedure of steps (1) and (2) after pasting gum tape to the back of the plate.
- (4) When pasting the shield plate to the back of the D motor PC board, be sure to align its corner with the left side base surface in the right angle.

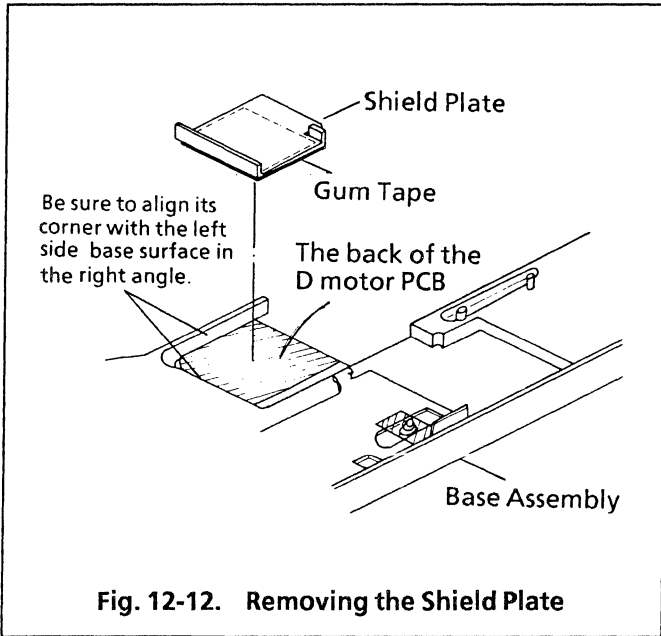

Fig. 12-12. Removing the Shield Plate

12.13 Removing and Remounting the Microswitch Assembly

- (1) Remove the holder assembly according to the procedure in section 12.4.
- (2) Remove the three soldered portions of the microswitch assembly lead wires on the D motor PC board.
- (3) Remove the microswitch assembly set screw and remove the microswitch assembly.
- (4) Remount the microswitch assembly in the reverse procedure of steps (1) to (3).
- (5) Observe the instructions in the following table when soldering the three lead wires onto the D motor PC board.

No. on the D motor PC board	Color of lead wire
1	Yellow
2	White
3	Blue

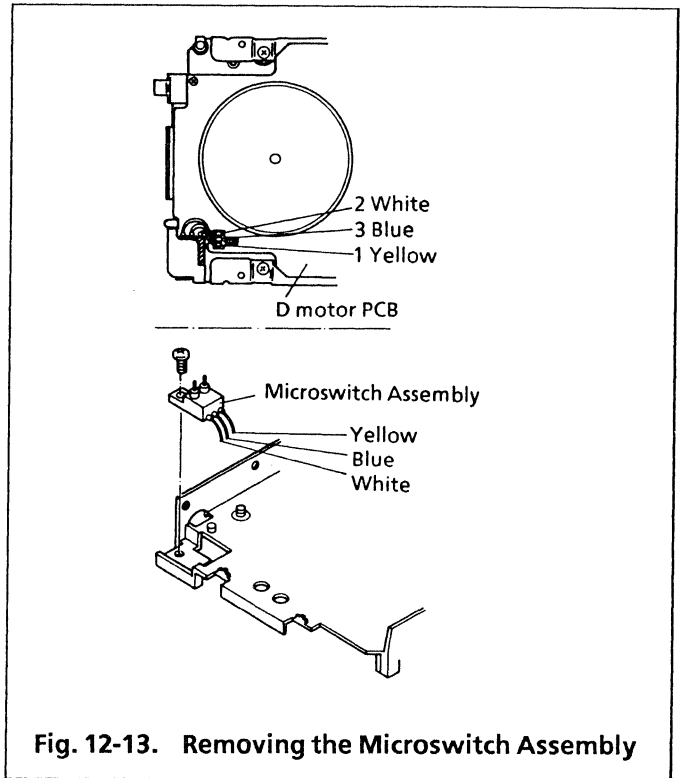

Fig. 12-13. Removing the Microswitch Assembly

12.14 Removing and Remounting the Mounting Brackets

- (1) Remove the four screws on the right and left side bracket assemblies and remove the right and left side bracket assemblies.
- (2) Remount the bracket in the reverse procedure of step (1) with care not to pinch the D motor cable by the mounting bracket.

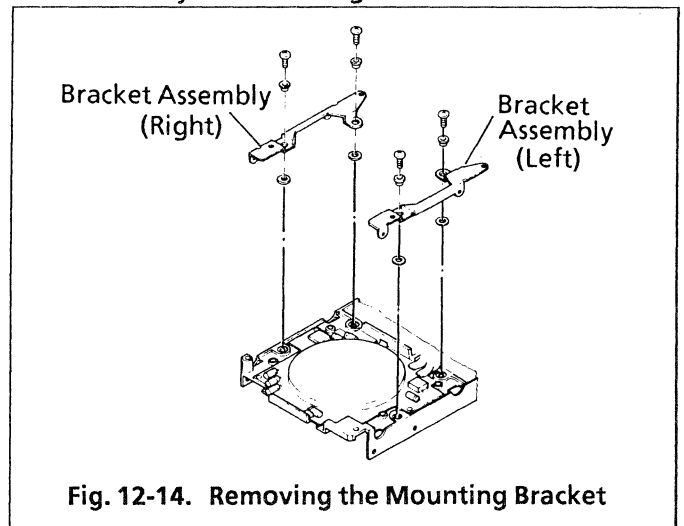
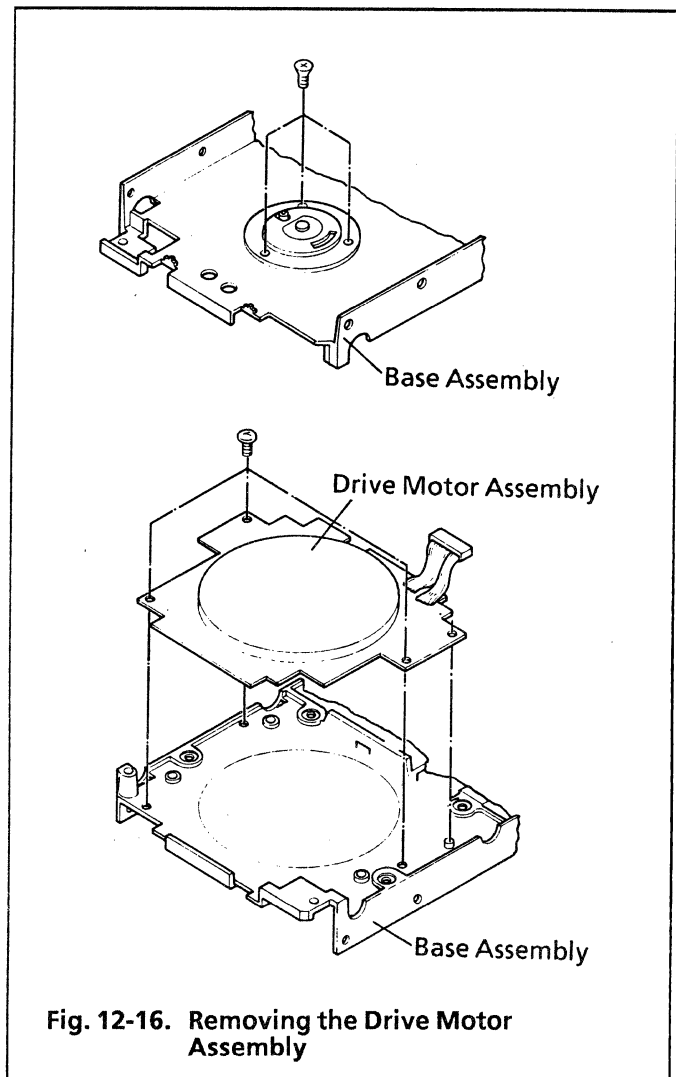
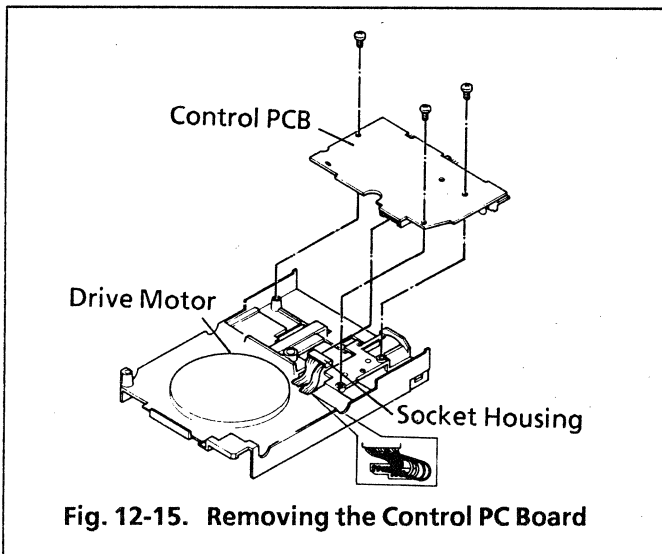

Fig. 12-14. Removing the Mounting Bracket

12.15 Removing and Remounting the Control PC Board

- (1) Remove the mounting bracket according to the procedure in section 12.14.
- (2) Remove the head FPC, track \emptyset connector, and stepper motor connector according to the procedure in section 12.5.
- (3) Remove the three set screws from the control PC board.
- (4) Remove the D motor PC board socket housing from the connector J5 and remove the control PC board.
- (5) Remount the control PC board in the reverse procedure of steps (1) to (4).
- (6) Treat the cable in the D motor PC board socket housing as shown in figure 12-15.



12.16 Removing and Remounting the Drive Motor Assembly

- (1) Remove the holder assembly according to the procedure in section 12.4.
- (2) Remove the control PC board according to the procedure in section 12.15.
- (3) Remove the microswitch assembly according to the procedure in section 12.13.
- (4) Remove the three front (head side) drive motor set screws.
- (5) Remove the three back (PC board side) drive motor set screws and remove the drive motor assembly.

12.17 Disassembling and Reassembling the Mounting Bracket Assembly

- (1) Press the collar bracket from beneath the mounting bracket assembly with a minus screwdriver, then the collar bracket and washer are removed from the holes in the mounting bracket.
- (2) Reassemble the mounting bracket assembly in the reverse order of step (1).

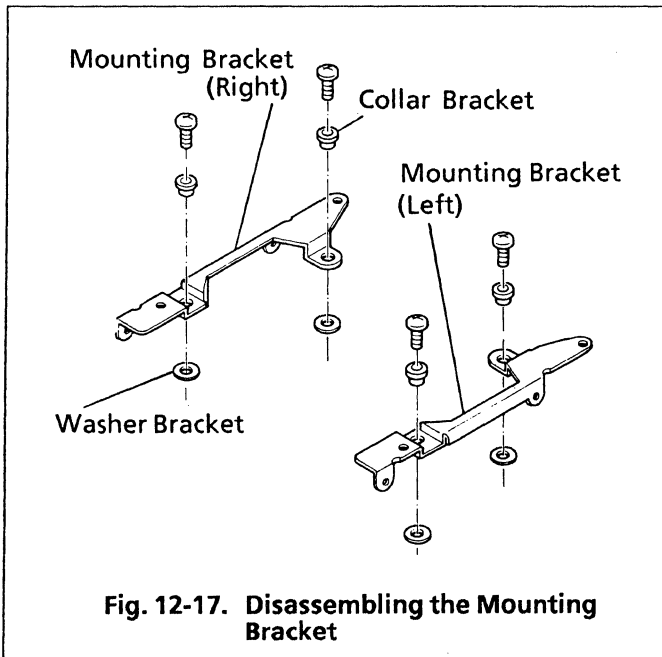

12.18 Removing and Remounting the Pushbutton

- (1) Pull down the pushbutton with its hook and remove the pushbutton from the eject lever. Push **A** with flat blade screwdriver while pulling out.
- (2) Remount the pushbutton in the reverse procedure of step (1).

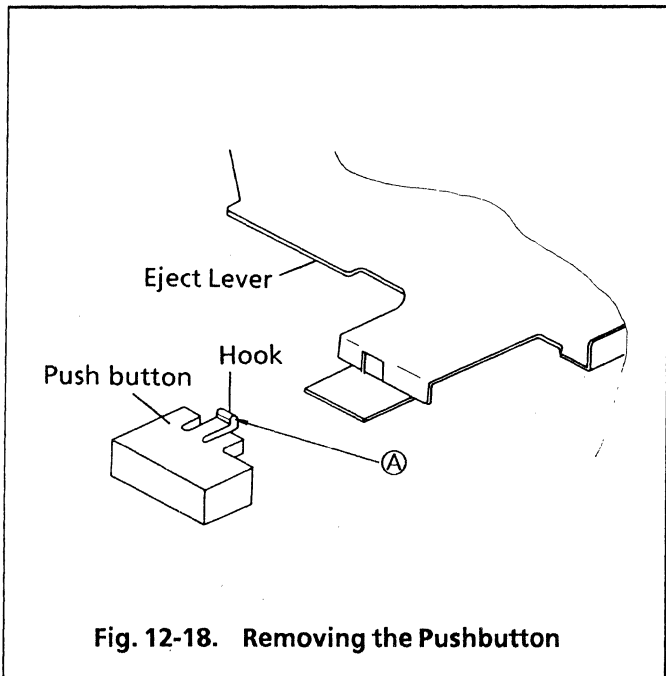

12.19 Disassembling and Reassembling the Holder Assembly

- (1) Remove the hooks of the shutter lever spring from the shutter lever assembly and from the holder.

- (2) Move the shutter lever assembly in the arrow direction in the figure riding across the stopper until it reaches the dotted line position, remove the shutter lever assembly with the tab on the holder aligned with the hole, and remove the shutter lever spring from the holder.
- (3) Remove the reverse insertion preventive lever spring from the tab.
- (4) Move the reverse insertion preventive lever until it reaches the dotted line position and remove it with the tab on the holder aligned with the hole.
- (5) Reassemble the holder assembly in the reverse procedure of steps (1) to (4).

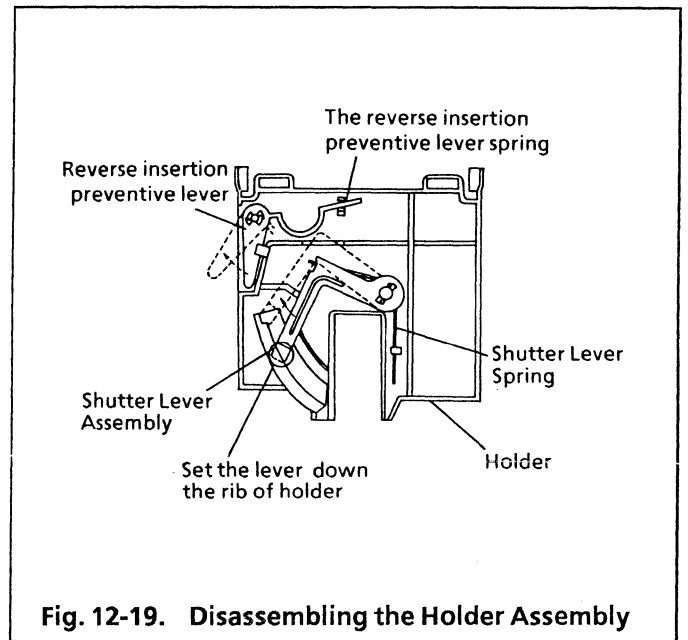

12.20 Mounting the Drive Motor LED

- (1) Solder the LED in the position indicated in figure 12-20.

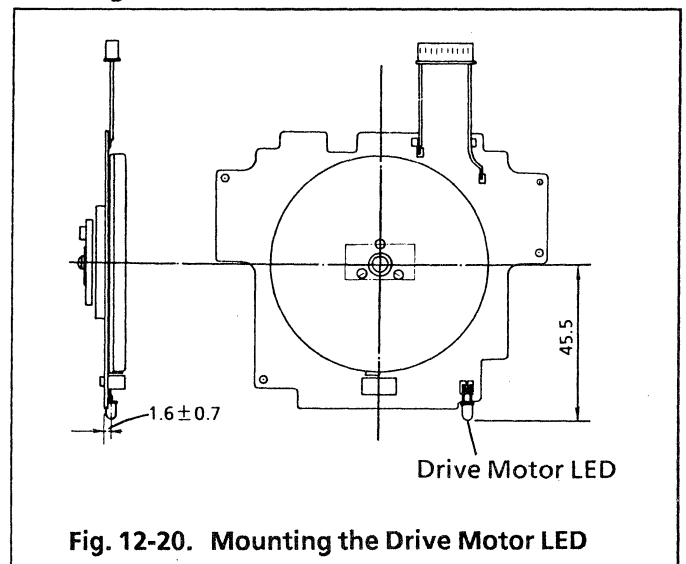

PART. 2 [JU-253-P/-PK]

12. DISASSEMBLY AND REASSEMBLY

12.1 Removing and Remounting the Cover

- (1) Remove two cover setscrews.
- (2) Disengage the cover from the claws in the four corners of the base and then remove the cover.
- (3) Mount the cover in the sequence of (2) to (1) in the above.

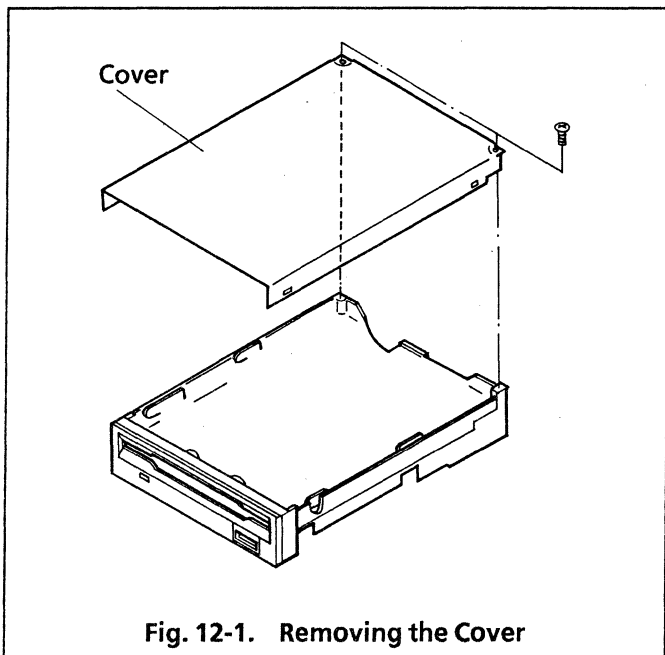

12.2 Removing and Remounting the Front Panel Assembly

- (1) Remove two front-panel setscrews and remove the front cover.
- (2) Remount the front panel in the reverse procedure of step (1) so that the button is inserted into the button hole in the front panel.

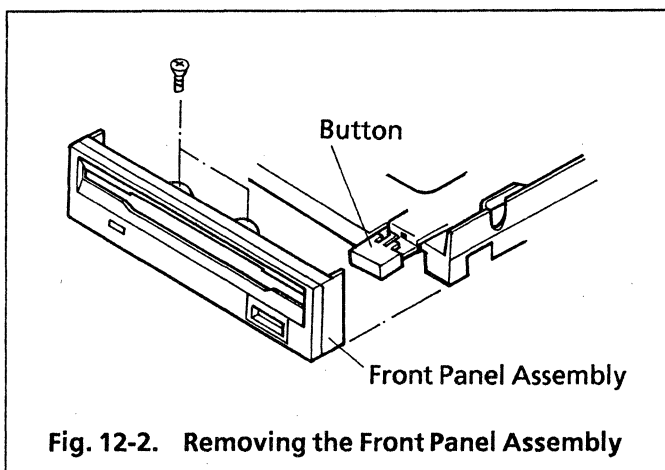

12.3 Removing and Remounting the Holder Assembly and Rollers

- (1) Remove the cover and front panel in the manners described in sections 12.1 and 12.2.
- (2) Press the eject button to its full stroke so that the roller section of the holder assembly can be easily ejected.
- (3) Lift the holder assembly by hands and gently slide it toward you, then the four roller sections on the holder will be removed from the eject levers. (Keep in mind that the rollers drop easily.) In this case, when the side 1 of the head assembly drops from the holder, it strikes the head on the side 0 being pushed by the side 1 head retaining spring, so lift it lightly by the thumb.
- (4) Remove the four rollers from the holder assembly.
- (5) Remount the rollers and holder assembly in the reverse procedure of steps (1) to (4).

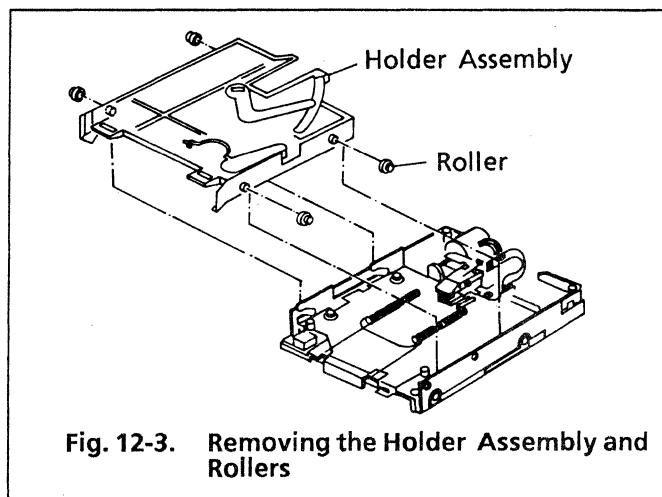

12.4 Removing and Remounting the Head FPC, Track 0 Connector, and Stepper Motor Connector

- (1) Draw the contact section of the head FPC upwards out of the head connector J6 by pinching it by flat pens with care not to damage it.
- (2) Remove the track 0 cable connector (red) from the connector J3 (on the stepper motor side, red) on the PCB.
- (3) Remove the stepper motor cable connector (brown) from the connector J4 (on the track 0 side, brown).

- (4) Remount the above in the reverse procedure of steps (1) to (3).
In this case, be sure to insert the head FPC to the full extent in the right angle. Wiring should be made so that the lead wire of the track 0 and the stepper motor does not contact the carriage of the head or hang over the track 0.
- (5) Ensure that the head FPC is not higher than the track 0 assembly.
- (6) Ensure that the head FPC does not contact the head of the track 0 assembly set screw.

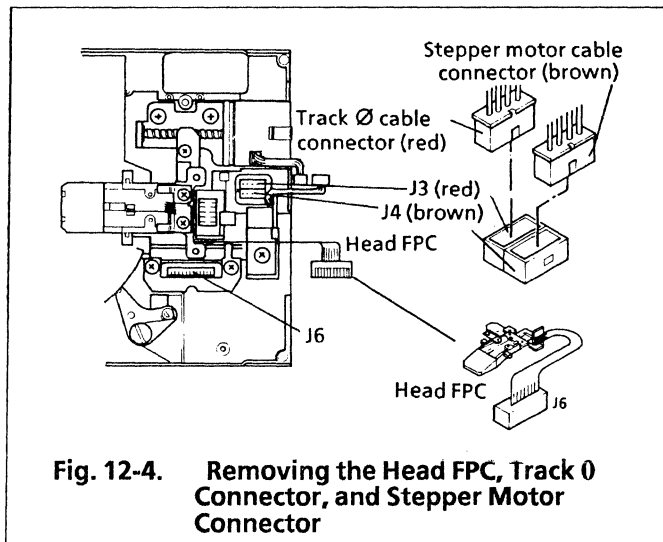

Fig. 12-4. Removing the Head FPC, Track 0 Connector, and Stepper Motor Connector

12.5 Removing and Remounting the Head Carriage Assembly, Rod Clamp, and Guide Rod

- (1) Remove the holder assembly according to the procedure in section 12.3.
- (2) Remove the head FPC from the connector J6 according to the procedure in section 12.4.
- (3) Remove two set screws on the rod and remove the rod clamp.
- (4) Move the head carriage assembly in the reverse direction of the stepper motor (rightward) and remove it.
- (5) Draw the guide rod out of the head carriage assembly.
- (6) Remount the above in the reverse procedure of steps (1) to (5).

[Cautions for Remounting]

- (7) Apply oil to the guide rod (but not too much), insert the rod into the head assembly, move it back and forth several times, and confirm that the guide rod moves smoothly.

- (8) Place the position where the head carriage assembly pinches the stepper motor lead screw at the center of the lead screw length.
- (9) Place the mounting position of the guide rod on the base so that the tail end of the guide rod comes to the same position as the base or projected less than 1 mm.
- (10) After remounting the above, adjust the radial alignment according to the procedure in section 9.6, adjust the track 00 sensor according to the procedure in section 9.9.

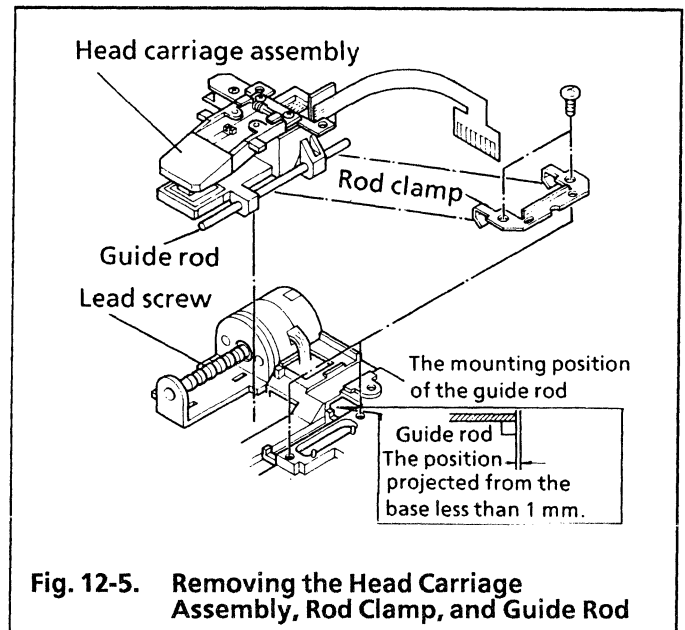
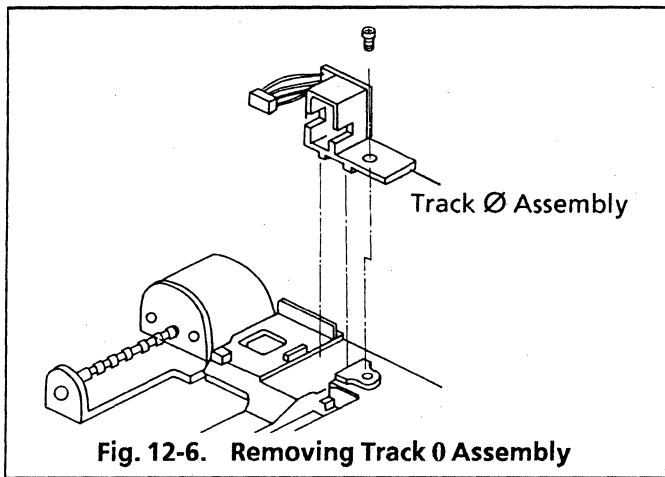

Fig. 12-5. Removing the Head Carriage Assembly, Rod Clamp, and Guide Rod

12.6 Removing and Remounting the Track 0 Assembly

- (1) Remove the cover according to the procedure in section 12.1.
- (2) Remove the track 0 cable connector according to the procedure in section 12.4.
- (3) Remove the set screw on the track 0 assembly and remove the track 0 assembly.
- (4) Remount the track 0 assembly in the reverse procedure of steps (1) to (3).
- (5) After remounting track 0 assembly, adjust the track 00 sensor according to the procedure in 9.9.



12.7 Removing and Remounting the Stepper Motor

- (1) Remove the cover according to the procedure in section 12.1.
- (2) Remove the stepper motor cable connector according to the procedure in section 12.4.
- (3) Remove the two set screws on the stepper motor and remove the stepper motor.
- (4) Remount the stepper motor in the reverse procedure of steps (1) to (30).
- (5) Ensure that the temporary fastened position of the stepper motor is placed so that the two projections on the base come to the centers of the two long holes in the stepper motor respectively.
- (6) Apply* grease to the lead screw of the stepper motor according to the procedures in steps (7) and (8).
- (7) Put grease in the size of a grain of rice on the lead screw.
- (8) Extend the grease over the lead screw evenly using an applicator.
- (9) After remounting the stepper motor, adjust the radial alignment according to the procedure in section 9.6, adjust the track 00 sensor according to the procedure in section 9.9.

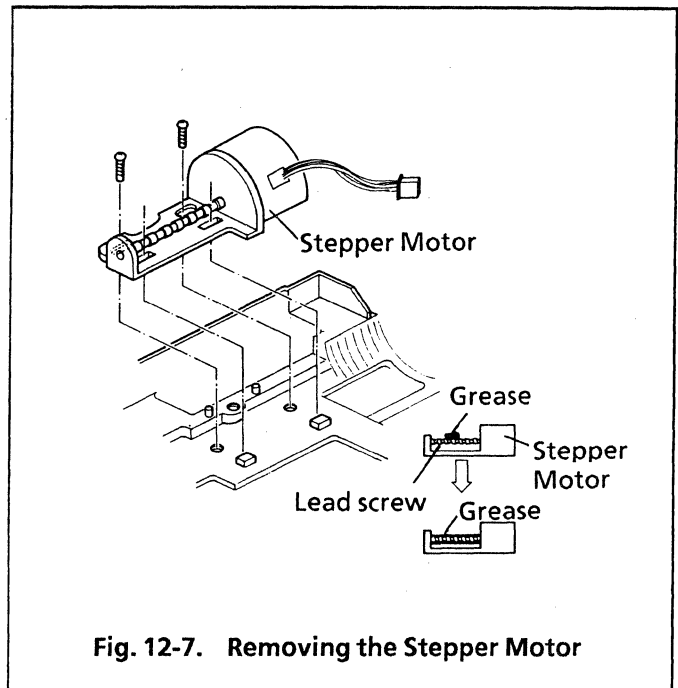

12.8 Removing and Remounting the Trigger Lever Assembly

- (1) Remove the cover according to the procedure in section 12.1.
- (2) Remove the trigger lever set screws and remove the trigger lever spring and trigger lever assembly.
- (3) Remount the above in the reverse procedure of steps (1) and (2).

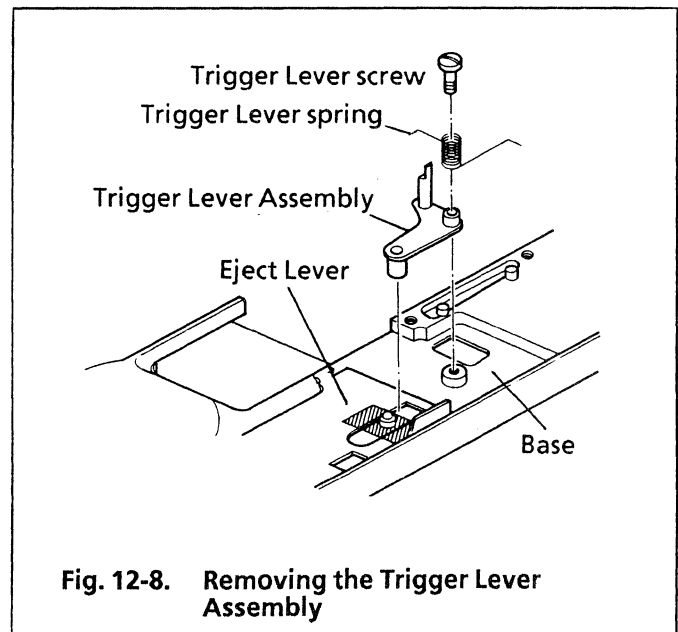

12.9 Removing and Remounting the Eject Lever Springs

- (1) Remove the holder assembly according to the procedure in section 12.4.
- (2) Remove the hook of the eject lever spring and remove the eject lever spring.
- (3) Remount the eject lever spring in the reverse procedure of steps (1) and (2).

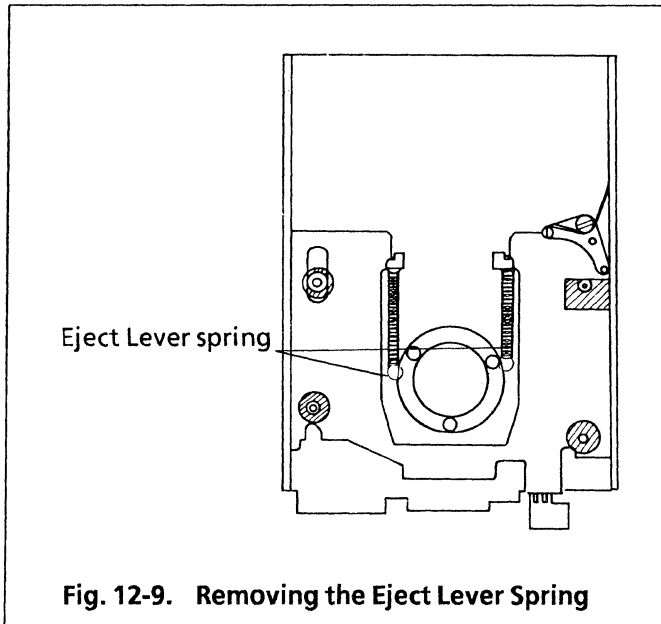

Fig. 12-9. Removing the Eject Lever Spring

12.10 Removing and Remounting the Eject Lever

- (1) Remove the eject lever springs according to the procedure in section 12.9.
- (2) Remove the trigger lever assembly according to the procedure in section 12.8.
- (3) Remove the four stopper rings and washers from the eject lever.
Each stopper ring has a slit, so it can be easily removed by pinching the portion adjacent to the slit by tweezers.
- (4) Remove the eject lever.
- (5) Remount the eject lever in the reverse procedure of steps (1) to (4).

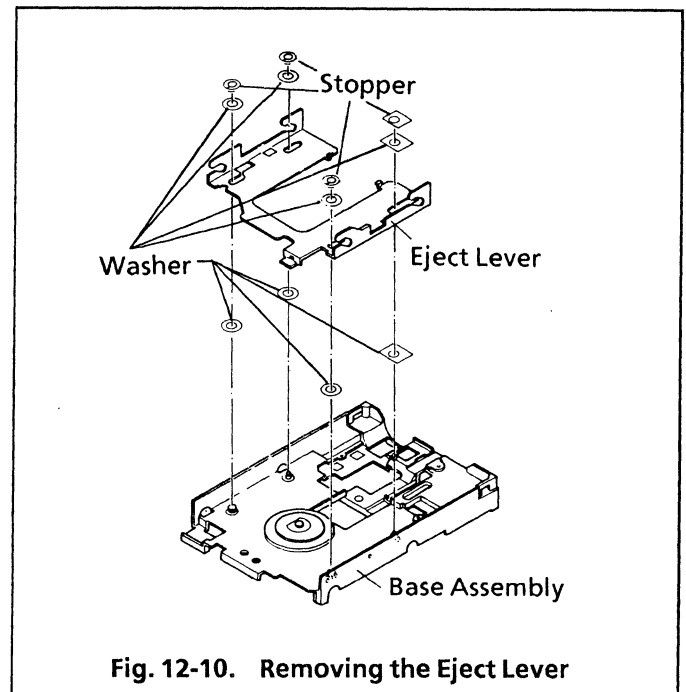

Fig. 12-10. Removing the Eject Lever

12.11 Removing and Remounting the Microswitch Assembly

- (1) Remove the holder assembly according to the procedure in section 12.3.
- (2) Remove the three soldered portions of the microswitch assembly lead wires on the D motor PC board.
- (3) Remove the microswitch assembly set screw and remove the microswitch assembly.
- (4) Remount the microswitch assembly in the reverse procedure of steps (1) to (3).
- (5) Observe the instructions in the following table when soldering the three lead wires onto the D motor PC board.

No. on the D motor PC board	Color of lead wire
1	Yellow
2	White
3	Blue

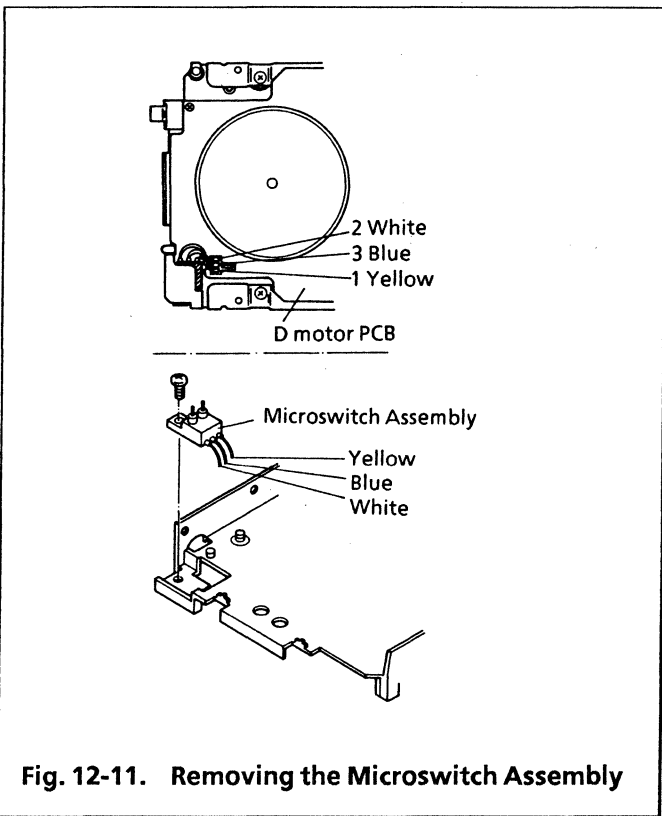

Fig. 12-11. Removing the Microswitch Assembly

12.12 Removing and Remounting the Mounting Brackets

- (1) Remove the four screws on the right and left side bracket assemblies and remove the right and left side bracket assemblies.
- (2) Remount the bracket in the reverse procedure of step (1) with care not to pinch the D motor cable by the mounting bracket.

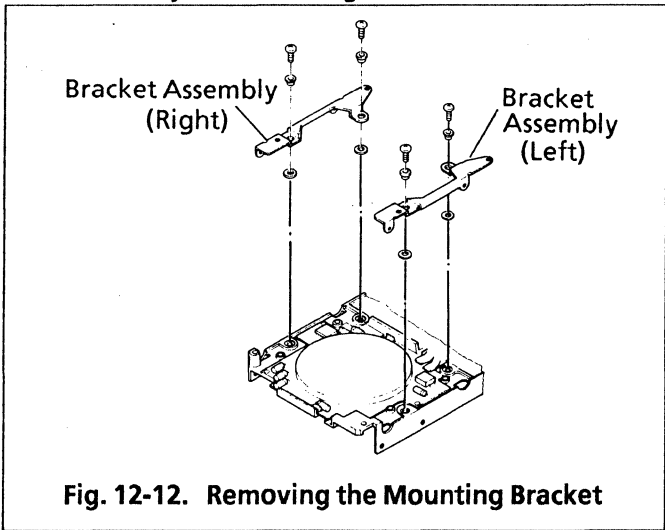

Fig. 12-12. Removing the Mounting Bracket

12.13 Removing and Remounting the Control PC Board

- (1) Remove the mounting bracket according to the procedure in section 12.12.
- (2) Remove the head FPC, trackØ connector, and stepper motor connector according to the procedure in section 12.4.
- (3) Remove the three set screws from the control PC board.
- (4) Remove the D motor PC board socket housing from the connector J5 and remove the control PC board.
- (5) Remount the control PC board in the reverse procedure of steps (1) to (4).
- (6) Treat the cable in the D motor PC board socket housing as shown in figure 12-15.

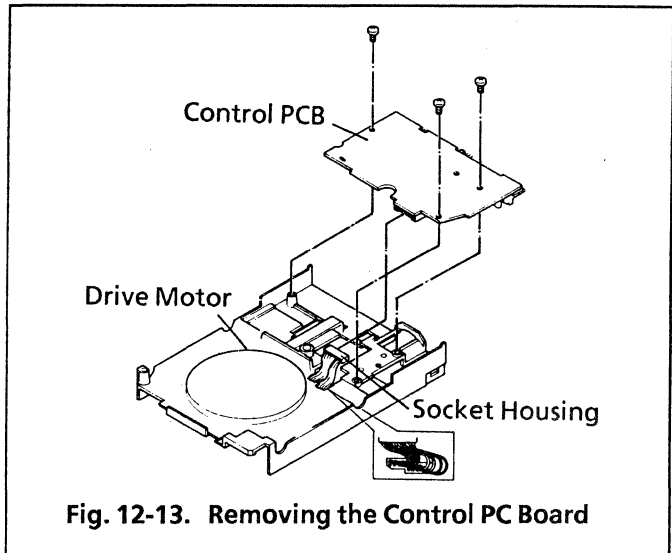
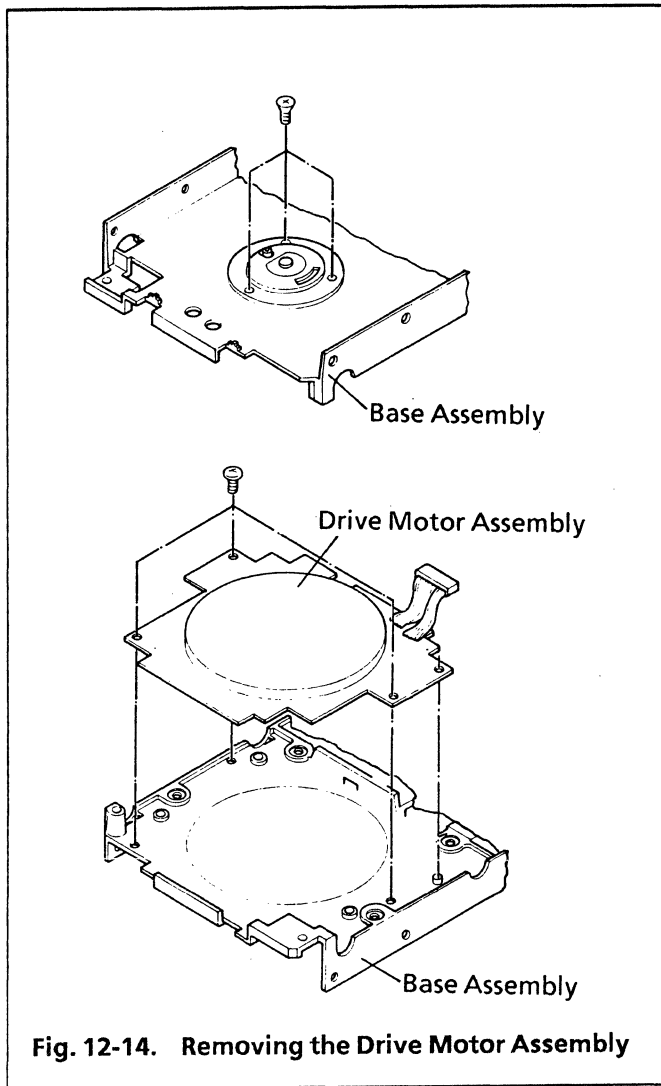

Fig. 12-13. Removing the Control PC Board

12.14 Removing and Remounting the Drive Motor Assembly

- (1) Remove the holder assembly according to the procedure in section 12.3.
- (2) Remove the control PC board according to the procedure in section 12.13.
- (3) Remove the microswitch assembly according to the procedure in section 12.11.
- (4) Remove the three front (head side) drive motor set screws.
- (5) Remove the three back (PC board side) drive motor set screws and remove the drive motor assembly.



12.15 Disassembling and Reassembling the Mounting Bracket Assembly

- (1) Press the collar bracket from beneath the mounting bracket assembly with a minus screwdriver, then the collar bracket and washer are removed from the holes in the mounting bracket.
- (2) Reassemble the mounting bracket assembly in the reverse order of step (1).

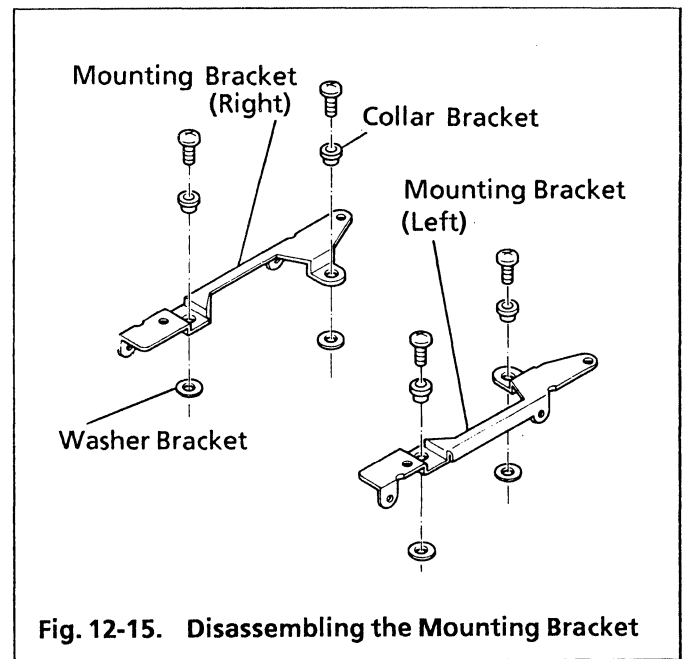

12.16 Removing and Remounting the Pushbutton

- (1) Pull down the pushbutton with its hook and remove the pushbutton from the eject lever. Push (A) with flat blade screwdriver while pulling out.
- (2) Remount the pushbutton in the reverse procedure of step (1).

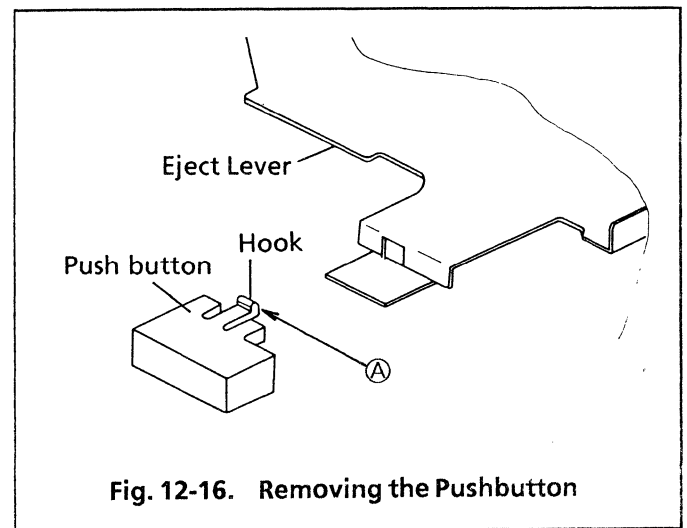

12.17 Disassembling and Reassembling the Holder Assembly

- (1) Remove the hooks of the shutter lever spring from the shutter lever assembly and from the holder.

- (2) Move the shutter lever assembly in the arrow direction in the figure riding across the stopper until it reaches the dotted line position, remove the shutter lever assembly with the tab on the holder aligned with the hole, and remove the shutter lever spring from the holder.
- (3) Remove the reverse insertion preventive lever spring from the tab.
- (4) Move the reverse insertion preventive lever until it reaches the dotted line position and remove it with the tab on the holder aligned with the hole.
- (5) Reassemble the holder assembly in the reverse procedure of steps (1) to (4).

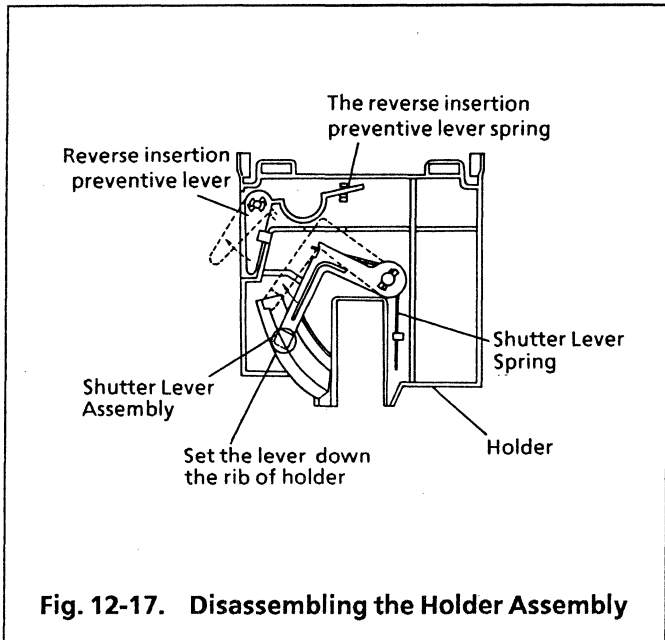
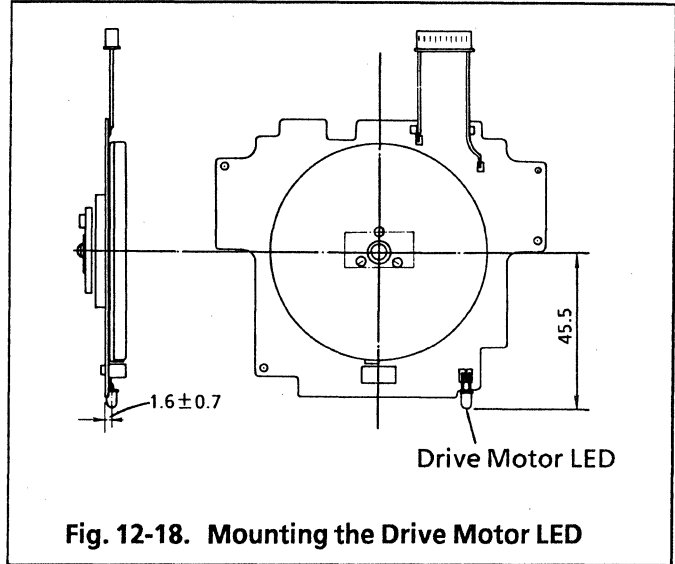

Fig. 12-17. Disassembling the Holder Assembly

12.18 Mounting the Drive Motor LED

- (1) Solder the LED in the position indicated in figure 12-18.



13. EXPLODED VIEW 1 - 1 [JU-253-01T]

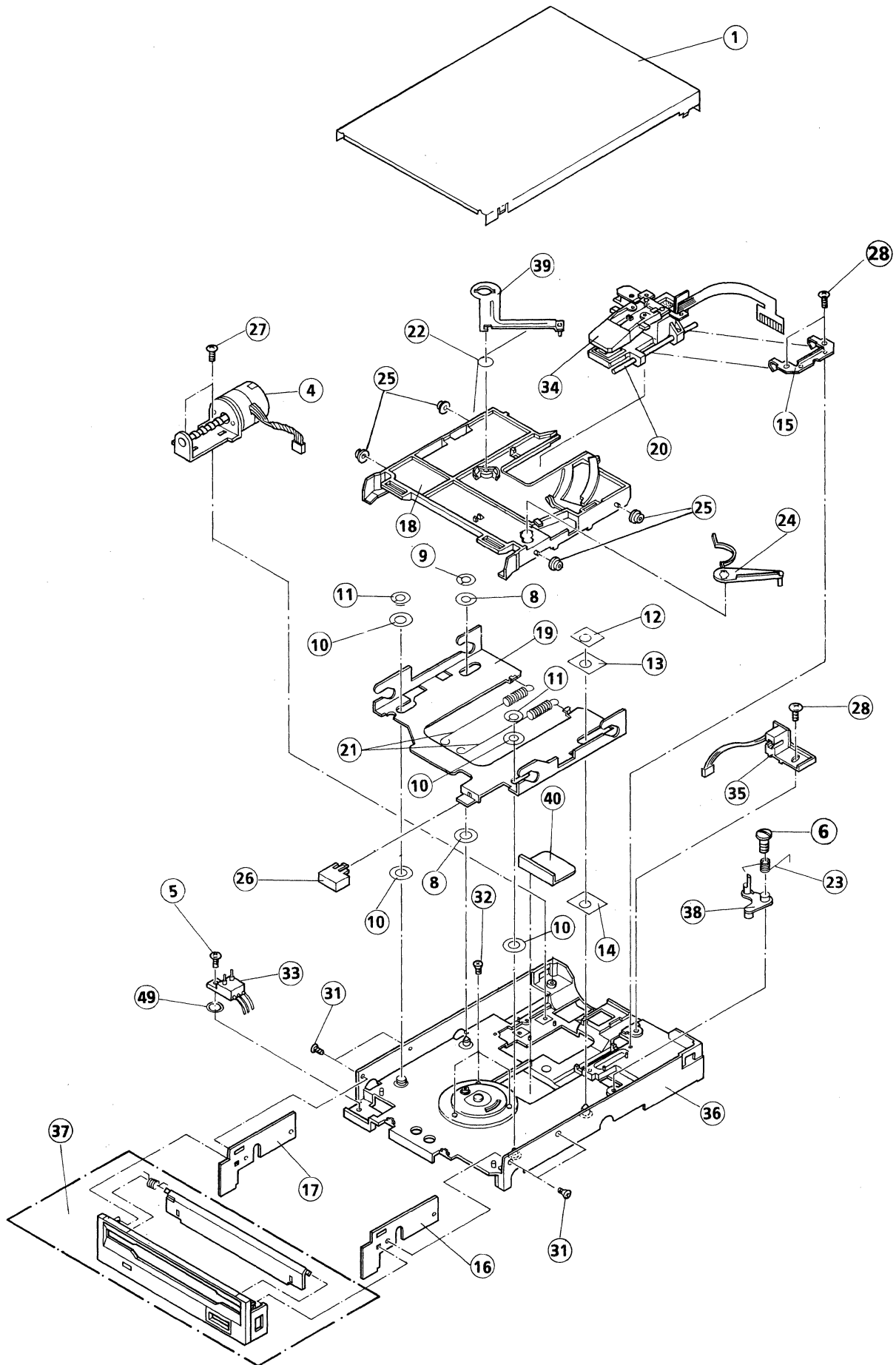

EXPLODED VIEW 1 - 2 [JU-253-01T]

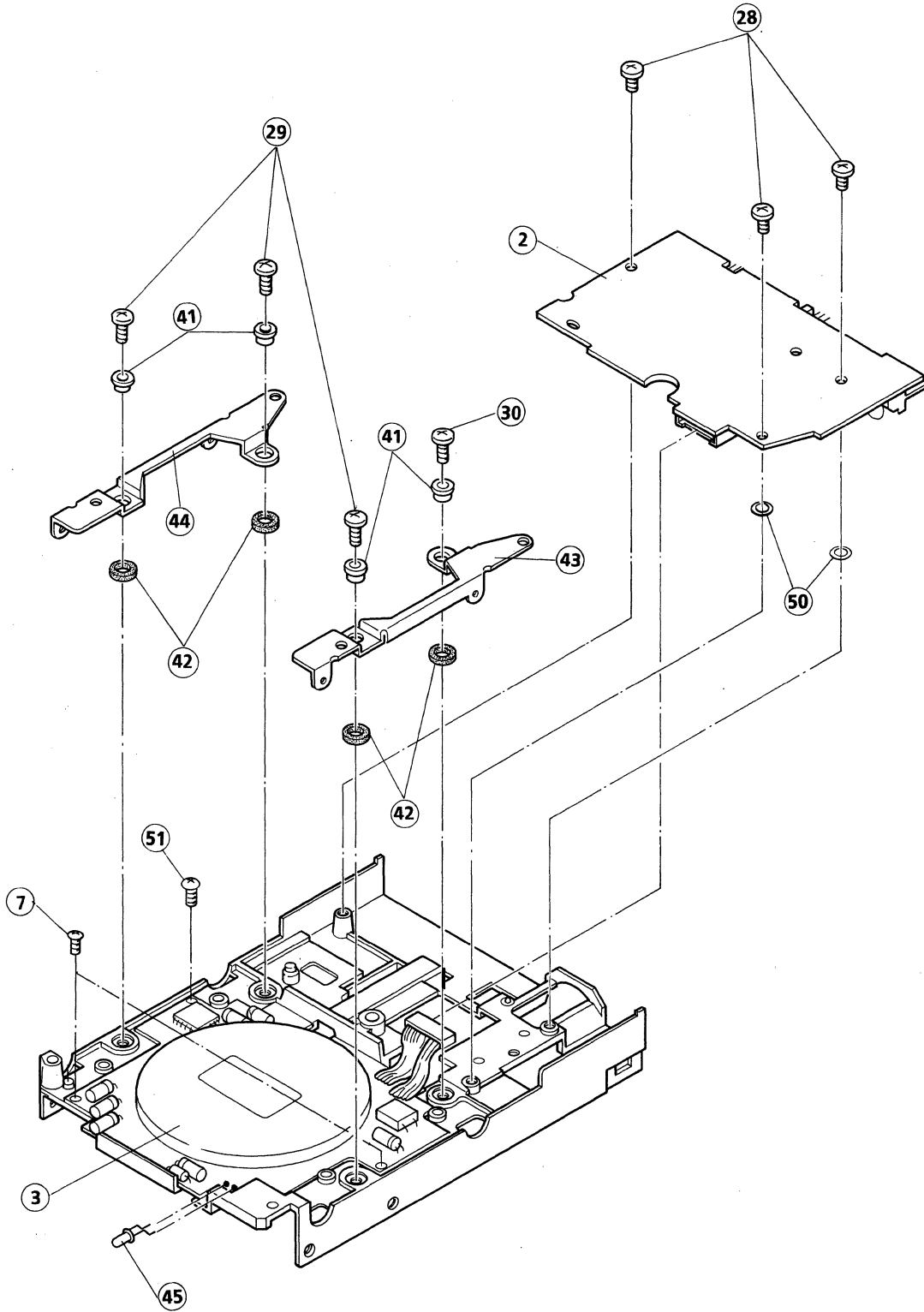

EXPLODED VIEW 2 - 1 [JU-253-01P / -01PK]

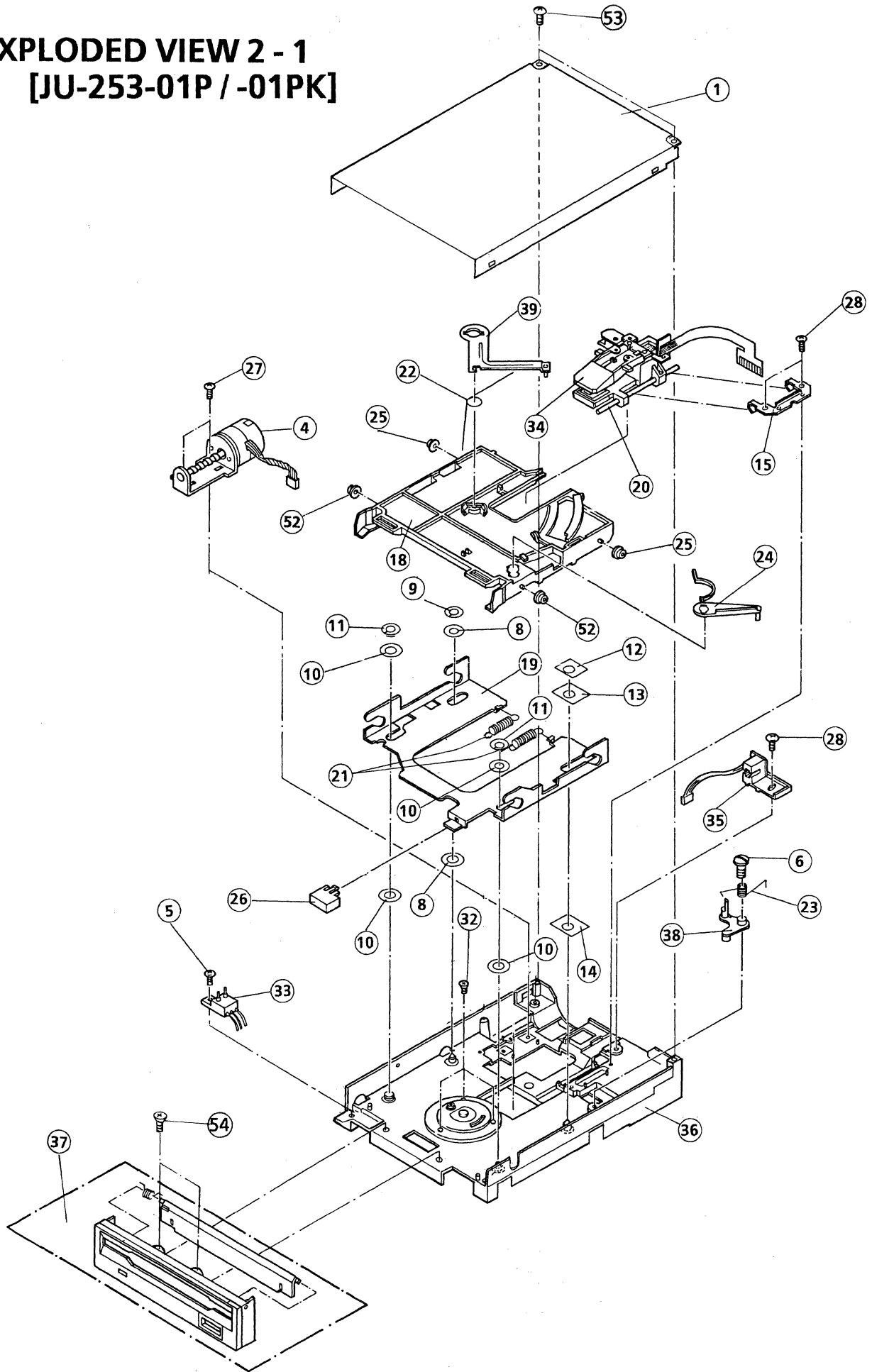

EXPLODED VIEW 2 - 2 [JU-253-01P / -01PK]

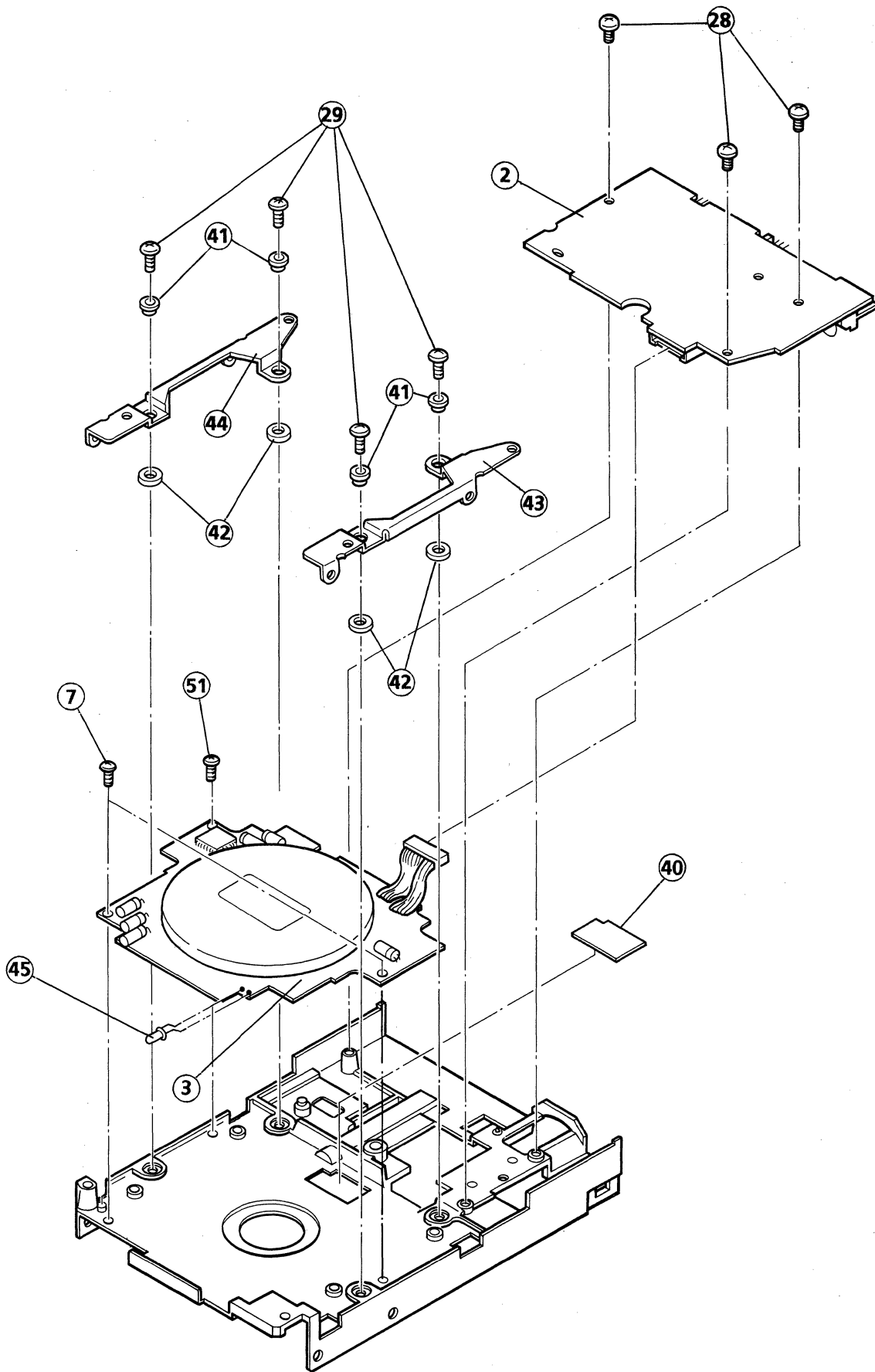

14. REPLACEMENT PARTS LIST 1 - 1

MODEL : JU - 253 - 01T

Ref.No.	Part No	Part Name & Description	Per Set (pcs.)	※ RSP	Remarks
1	YTF5E02083B3	Cover	1		
2	UF253TPK - CN	Control Print Circuit Board Assembly	1	2	
3	YTFMD02280B4	Drive Motor	1	2	
	YTUF35DMTJ-4				
4	YTFMD02400B4	Stepper Motor	1	2	
5	YTF1E00550B4	Screw (For Micro Switch Assembly)	1		
6	YTF1E00702B4	Screw (For Trigger Lever)	1		
7	YTF1E00770B4	Screw (For Drive Motor PCB)	2		
8	YTF1K00121B4	Washer 06	2		
9	YTF1K00171B4	Stopper 05.6	1		
10	YTF1K00370B4	Washer C	4		
11	YTF1K00390B4	Stopper C	2		
12	YTF1K00530B4	Stopper F	1		
13	YTF1K00760B4	Washer	1		
14	YTF1K00950B4	Washer	1		
15	YTF2C05500B4	Clamp (For Guide Rod)	1		
16	YTF2S08040B4	Guide Plate (Right)	1		
17	YTF2S08050B4	Guide Plate (Left)	1		
18	YTF2K0551AB2	Holder	1		
19	YTF2K05524B3	Eject Lever	1		
20	YTF4H02490B4	Guide Rod	1		
21	YTF4J03680B4	Spring (For Eject Lever)	2		
22	YTF4J02543B4	Spring (For Shutter Lever)	1		
23	YTF4J02661B4	Spring (For Trigger Lever)	1		
24	YTF4R02553B4	Lever (Prevented Incorrect Insertion)	1		
25	YTF3F08031B4	Roller	4		
26	YTF6J02103B4	Button (For Eject)	1	3	
27	YTF1E00990B4	Screw (For Stepper Motor)	2		
28	XSB25 + 4FX	Screw [Clamp (2), TRKØ Assy(1), Control PCB(3)]	6		
29	XSB25 + 6FX	Screw (For Bracket)	3		
30	YTF1E00981B4	Screw (For Bracket)	1		
31	XSS2 + 3FX	Screw (For Guide Plate)	4		
32	XSS2 + 4FX	Screw (For Drive Motor)	3		
33	YTUF253DET	Micro Switch Assembly	1	2	
34	YTUF253HD1	Head Assembly	1	2	
35	YTUF253TR0	TrackØ Assembly	1	2	
36	YTF7K08211B3	Base Assembly	1		
37	YTF7K06123B3	Front Panel Assembly (Attached Shutter)	1	3	
38	YTF7K08830B4	Trigger Lever Assembly	1		
39	YTF7K08440B4	Shutter Lever Assembly	1		
40	YTF2H05931B4	Shield Plate	1		
41	YTF2P05910B4	Collar (For Bracket)	4		
42	YTF2P05921B4	Washer (For Bracket)	4		
43	YTF2S05560B4	Bracket (Left)	1		
44	YTF2S05550B4	Bracket (Right)	1		
45	LN28RP	LED (On Motor PCB)	1		
49	YTF1K00441B4	Stopper A (For Micro Switch Assembly)	1		
50	YTF1K00780B4	Washer (For Control PCB)	2		
51	YTF1E01241B4	Screw (For Drive Motor PCB)	1		

※ RSP : Recommend Service Parts per 1,000 Units.

Caution : 1. PCB Assembly is produced to order during the production period only.

2. When you order the aforementioned parts, be sure to specify "Part No." of the parts ordered.

REPLACEMENT PARTS LIST 1-2

MODEL : JU - 253 - 01P

Ref.No.	Part No	Part Name & Description	Per Set (pcs.)	※RSP	Remarks
1	YTF2K08240B3	Cover	1		
2	UF253TPK - CN	Control Print Circuit Board Assembly	1	2	
3	YTUF35DMTJ-4	Drive Motor	1	2	
	YTFMD02280B4				
4	YTFMD02551B4	Stepper Motor	1	2	
5	YTF1E00550B4	Screw (For Micro Switch Assembly)	1		
6	YTF1E00702B4	Screw (For Trigger Lever)	1		
7	YTF1E00770B4	Screw (For Drive Motor PCB)	2		
8	YTF1K00121B4	Washer 06	2		
9	YTF1K00171B4	Stopper 05.6	1		
10	YTF1K00370B4	Washer C	4		
11	YTF1K00390B4	Stopper C	2		
12	YTF1K00530B4	Stopper F	1		
13	YTF1K00760B4	Washer	1		
14	YTF1K00363B4	Washer	1		
15	YTF2C08060B4	Clamp (For Guide Rod)	1		
18	YTF2K0551AB2	Holder	1		
19	YTF2K07830B3	Eject Lever	1		
20	YTF4H03730B4	Guide Rod	1		
21	YTF4J03630B4	Spring (For Eject Lever)	2		
22	YTF4J02543B4	Spring (For Shutter Lever)	1		
23	YTF4J02661B4	Spring (For Trigger Lever)	1		
24	YTF4R02553B4	Lever (Prevented Incorrect Insertion)	1		
25	YTF4S03620B4	Roller	2		
26	YTF6J03460B4	Button (For Eject)	1	3	
27	YTF1E00990B4	Screw (For Stepper Motor)	2		
28	XSB25 + 4FX	Screw [Clamp (2), TRKØ Assy(1), Control PCB(3)]	6		
29	XSB25 + 6FX	Screw (For Bracket)	4		
32	XSS2 + 4FX	Screw (For Drive Motor)	3		
33	YTUF253DET	Micro Switch Assembly	1	2	
34	YTUF253PHD	Head Assembly	1	2	
35	YTUF253TR0	TrackØ Assembly	1	2	
36	YTF7K08481B3	Base Assembly	1		
37	YTF7K08560B3	Front Panel Assembly (Attached Shutter)	1	3	
38	YTF7K08830B4	Trigger Lever Assembly	1		
39	YTF7K09210B4	Shutter Lever Assembly	1		
40	YTF2H08260B4	Shield Plate	1		
41	YTF2P05910B4	Collar (For Bracket)	4		
42	YTF2P05921B4	Washer (For Bracket)	4		
43	YTF2S05560B4	Bracket (Left)	1		
44	YTF2S05550B4	Bracket (Right)	1		
45	LN28RP	LED (On Motor PCB)	1		
51	YTF1E01241B4	Screw (For Drive Motor PCB)	1		
52	YTF4S03550B4	Roller	2		
53	XSN2 + 5FX	Screw (For Cover)	2		
54	YTF1E01400B4	Screw (For Front Panel)	2		

※ RSP : Recommend Service Parts per 1,000 Units.

Caution : 1. PCB Assembly is produced to order during the production period only.

2. When you order the aforementioned parts, be sure to specify "Part No." of the parts ordered.

REPLACEMENT PARTS LIST 1 - 3

MODEL : JU - 253 - 01PK

Ref.No.	Part No	Part Name & Description	Per Set (pcs.)	※ RSP	Remarks
1	YTF2K08240B3	Cover	1		
2	UF253TPK - CNK	Control Print Circuit Board Assembly	1	2	
3	YTUF35DMTJ-4	Drive Motor	1	2	
	YTFMD02280B4				
4	YTFMD02551B4	Stepper Motor	1	2	
5	YTF1E00550B4	Screw (For Micro Switch Assembly)	1		
6	YTF1E00702B4	Screw (For Trigger Lever)	1		
7	YTF1E00770B4	Screw (For Drive Motor PCB)	2		
8	YTF1K00121B4	Washer 06	2		
9	YTF1K00171B4	Stopper 05.6	1		
10	YTF1K00370B4	Washer C	4		
11	YTF1K00390B4	Stopper C	2		
12	YTF1K00530B4	Stopper F	1		
13	YTF1K00760B4	Washer	1		
14	YTF1K00363B4	Washer B	1		
15	YTF2C08060B4	Clamp (For Guide Rod)	1		
18	YTF2K0551AB2	Holder	1		
19	YTF2K07830B3	Eject Lever	1		
20	YTF4H03730B4	Guide Rod	1		
21	YTF4J03630B4	Spring (For Eject Lever)	2		
22	YTF4J02543B4	Spring (For Shutter Lever)	1		
23	YTF4J02661B4	Spring (For Trigger Lever)	1		
24	YTF4R02553B4	Lever (Prevented Incorrect Insertion)	1		
25	YTF4S03620B4	Roller	2		
26	YTF6J03460B4	Button (For Eject)	1	3	
27	YTF1E00990B4	Screw (For Stepper Motor)	2		
28	X5B25 + 4FX	Screw [Clamp (2), TRK∅ Assy(1), Control PCB(3)]	6		
29	X5B25 + 6FX	Screw (For Bracket)	4		
32	X5S2 + 4FX	Screw (For Drive Motor)	3		
33	YTUF253DET	Micro Switch Assembly	1	2	
34	YTUF253PHDK	Head Assembly	1	2	
35	YTUF253TR0	Track∅ Assembly	1	2	
36	YTF7K08481B3	Base Assembly	1		
37	YTF7K08560B3	Front Panel Assembly (Attached Shutter)	1	3	
38	YTF7K08830B4	Trigger Lever Assembly	1		
39	YTF7K09210B4	Shutter Lever Assembly	1		
40	YTF2H08260B4	Shield Plate	1		
41	YTF2P05910B4	Collar (For Bracket)	4		
42	YTF2P05921B4	Washer (For Bracket)	4		
43	YTF2S05560B4	Bracket (Left)	1		
44	YTF2S05550B4	Bracket (Right)	1		
45	LN28RP	LED (On Motor PCB)	1		
51	YTF1E01241B4	Screw (For Drive Motor PCB)	1		
52	YTF4S03550B4	Roller	2		
53	X5N2 + 5FX	Screw (For Cover)	2		
54	YTF1E01400B4	Screw (For Front Panel)	2		

※ RSP : Recommend Service Parts per 1,000 Units.

Caution : 1. PCB Assembly is produced to order during the production period only.

2. When you order the aforementioned parts, be sure to specify "Part No." of the parts ordered.

REPLACEMENT PARTS LIST OF PCB 2 - 1

MODEL : JU - 253 - 01T / - 01P

Component Side

Ref.No.	Part No.	Part Name & Description	Per Set (pcs.)	RSP	Remarks
R18	ERG15J101	Metal Film Resistor	1		
L4	LEM4532T101K	Low-Frequency Coil	1		
	FNC00100B101				
L2,3	LEM4532T151K	Low-Frequency Coil	2		
	FNC00100B151				
L6	SN3-209	Choke Coil	1		
IC1	HA13421AMP	IC (Stepper)	1	2	
IC2	HA16680MP	IC	1	2	
IC3	BA6580K-M	IC (R / W)	1	2	
VR1	EVMLJGA00B24	Variable Resistor	1		
X1	EFOFC2004A4B	Resonator	1		
CN1	YT08050705	Connector	1		
	FCN-725P034				
CN2	171826-4	Connector (Power)	1		
CN	YTFJC00760B4	Connector	1		
CN5	FJC00620B410	Connector (D-Motor)	1		
CN4	FJC00401B402	Connector	1		
CN3	FJC00401B409	Connector	1		
CN6	FJC00410B407	Connector	1		
L1	FBR06HA500	High Frequency Coil (Ferrite Beads)	1	2	
CN	IMSA-9215H-T	Short Plug	2		
IC4	HD74HC74FP80	IC	1		
Q7	DTC114TKT-97	Transistor	1		
ID1	NIKRD8-102	Diode Array	1		

Solder Side (1)

Ref.No.	Part No.	Part Name & Description	Per Set (pcs.)	RSP	Remarks
C1,4	FCC00560B152	Chip Capacitor	2		
C16	FCC00510B681	Chip Capacitor	1		
C15	FCC00510B151	Chip Capacitor	1		
C13,14	FCC00560B473	Chip Capacitor	2		
C21	FCC00560B222	Chip Capacitor	1		
C9	FCC00510B101	Chip Capacitor	1		
C10	FCC00510B221	Chip Capacitor	1		
R32	MCR18EZHZ101	Chip Resistor	1		
R2,3,4	MCR18EZHZ393	Chip Resistor	3		
R33,42	MCR18EZHZ472	Chip Resistor	2		
R38,39,41,81,83,85	MCR18EZHZ473	Chip Resistor	6		
R30	MCR18EZHZ331	Chip Resistor	1		

REPLACEMENT PARTS LIST OF PCB

MODEL : JU - 253 - 01T / - 01P

Solder Side (2)

Ref.No.	Part No.	Part Name & Description	Per Set (pcs.)	RSP	Remarks
R26,27	MCR18EZHJ751	Chip Resistor	2		
R22,23	MCR18EZHJ561	Chip Resistor	2		
R40	MCR18EZHJ301	Chip Resistor	1		
R19,20	MCR18EZHJ391	Chip Resistor	2		
R14	MCR18EZHJ272	Chip Resistor	1		
R11,12,13	MCR18EZHJ153	Chip Resistor	3		
R35	MCR18EZHJ752	Chip Resistor	1		
R8,9,34,51,52,53 54,58,60,65,67	MCR18EZHJ000	Chip Resistor	11		
D1,3,80	MA151A-TW	Diode	3	2	
D8,81	MA704-TW	Diode	2	2	
D4,6	MA159-TW	Chip Diode	2	2	
Q1	2SB1114T2BZL	Transistor	1	2	
Q2,3,6	2SB766-TX	Transistor	3	2	
C5,6,8,11,17,19,20	FCC00500B105	Chip Capacitor	7		
R1	MCR18EZHJ682	Chip Resistor	1		
R6	MCR18EZHJ223	Chip Resistor	1		
R36,37,71,80	MCR18EZHJ103	Chip Resistor	4		
C26,27,28,30	FCC00020B401	Chip Capacitor	4		
C18,22	TMK325F105ZB	Capacitor	2		
D7	MA151A-TX	Diode	1		
R75,82,84,86	MCR18EZHJ102	Chip Resistor	4		
R5	MCR18EZHJ105	Chip Resistor	1		
R24,25	MCR18EZHJ122	Chip Resistor	2		
R31	MCR18EZHJ181	Chip Resistor	1		
R74	MCR18EZHJ562	Chip Resistor	1		
R16,17	MCR18EZHJ912	Chip Resistor	2		
Q5,10,80	DTC114TKT-97 UN2215-TW	Transistor	3		
D2	MA151WA-TW DAN202KT-97	Diode	1		
D5	MA151WK-TW DAP202KT-97	Diode	1		
Q4	DTC114TKT-96 UN2215-TX	Transistor	1		
IC6	TC4S11FTE85L	IC	1		
IC7	TC4S69FTE85L	IC	1		
R28,29	FRA00100B102	Resistor	2		

REPLACEMENT PARTS LIST OF PCB 2 - 2

MODEL : JU - 253 - 01PK

Component Side

Ref.No.	Part No.	Part Name & Description	Per Set (pcs.)	RSP	Remarks
R18	ERD25TJ271	Carbon Resistor	1		
L4	LEM4532T101K	Low-Frequency Coil	1		
	FNC00030B424				
L2,3	LEM4532T151K	Low-Frequency Coil	2		
	FNC00030B426				
L6	SN3-209	Choke Coil	1		
IC1	HA13421AMP	IC (Stepper)	1	2	
IC2	HA16680MP	IC	1	2	
IC3	BA6580K-M	IC (R / W)	1	2	
VR1	EVMLJGA00B24	Variable Resistor	1		
X1	EFOFC2004A4B	Resonator	1		
CN1	YT08050705	Connector	1		
	FCN-725P034				
CN2	171826-4	Connector (Power)	1		
CN	YTFJC00760B4	Connector	1		
CN5	FJC00370B408	Connector (D-Motor)	1		
CN4	FJC00401B402	Connector	1		
CN3	FJC00401B409	Connector	1		
CN6	FJC00410B407	Connector	1		
L1	FBR06HA500	High Frequency Coil (Ferrite Beads)	1	2	
CN	IMSA-9215H-T	Short Plug	2		
IC4	HD74HC74FP80	IC	1		
Q7	DTC114TKT-97	Transistor	1		
ID1	NIKRD8-102	Diode Array	1		

Solder Side (1)

Ref.No.	Part No.	Part Name & Description	Per Set (pcs.)	RSP	Remarks
C1,4	FCC00030B410	Chip Capacitor	2		
C16	FCC00010B456	Chip Capacitor	1		
C15	FCC00010B440	Chip Capacitor	1		
C13,14	FCC00030B428	Chip Capacitor	2		
C21	FCC00030B412	Chip Capacitor	1		
C9	FCC00010B436	Chip Capacitor	1		
C10	FCC00010B444	Chip Capacitor	1		
R32	MCR18EZHZ101	Chip Resistor	1		
R2,3,4	MCR18EZHZ393	Chip Resistor	3		
R33,42	MCR18EZHZ472	Chip Resistor	2		
R38,39,41,81,83,85	MCR18EZHZ473	Chip Resistor	6		
R30	MCR18EZHZ331	Chip Resistor	1		

REPLACEMENT PARTS LIST OF PCB

MODEL : JU - 253 - 01PK

Solder Side (2)

Ref.No.	Part No.	Part Name & Description	Per Set (pcs.)	RSP	Remarks
R26,27	MCR18EZHZ751	Chip Resistor	2		
R22,23	MCR18EZHZ561	Chip Resistor	2		
R40	MCR18EZHZ301	Chip Resistor	1		
R19,20	MCR18EZHZ391	Chip Resistor	2		
R14	MCR18EZHZ222	Chip Resistor	1		
R11,12,13	MCR18EZHZ153	Chip Resistor	3		
R35	MCR18EZHZ752	Chip Resistor	1		
R9,34,51,52,53 54,58,60,61,65,67	MCR18EZHZ000	Chip Resistor	11		
D1,3,80	MA151A-TW	Diode	3	2	
D8,81	MA704-TW	Diode	2	2	
D4,6	MA159-TW	Chip Diode	2	2	
Q1	2SB1114T2BZL	Transistor	1	2	
Q2,3,6	2SB766-TX	Transistor	3	2	
C5,6,8,11,17,19,20	FCC00150B400	Chip Capacitor	7		
R1,16,17	MCR18EZHZ682	Chip Resistor	3		
R6	MCR18EZHZ223	Chip Resistor	1		
R36,37,71,80	MCR18EZHZ103	Chip Resistor	4		
C26,27,28,30	FCC00020B401	Chip Capacitor	4		
C18,22	TMK325F105ZB	Capacitor	2		
D7	MA151A-TX	Diode	1		
R75,82,84,86	MCR18EZHZ102	Chip Resistor	4		
R5	MCR18EZHZ105	Chip Resistor	1		
R24,25	MCR18EZHZ122	Chip Resistor	2		
R31	MCR18EZHZ181	Chip Resistor	1		
R74	MCR18EZHZ562	Chip Resistor	1		
Q5,10,80	DTC114TKT-97	Transistor	3		
	UN2215-TW				
D2	MA151WA-TW	Diode	1		
	DAN202KT-97				
D5	MA151WK-TW	Diode	1		
	DAP202KT-97				
Q4	DTC114TKT-96	Transistor	1		
	UN2215-TX				
IC6	TC4S11FTE85L	IC	1		
IC7	TC4S69FTE85L	IC	1		
R28,29	FRA00100B102	Resistor	2		

15. SCHEMATIC DIAGRAM OF CONTROL BOARD [JU-253-01T / -01P]

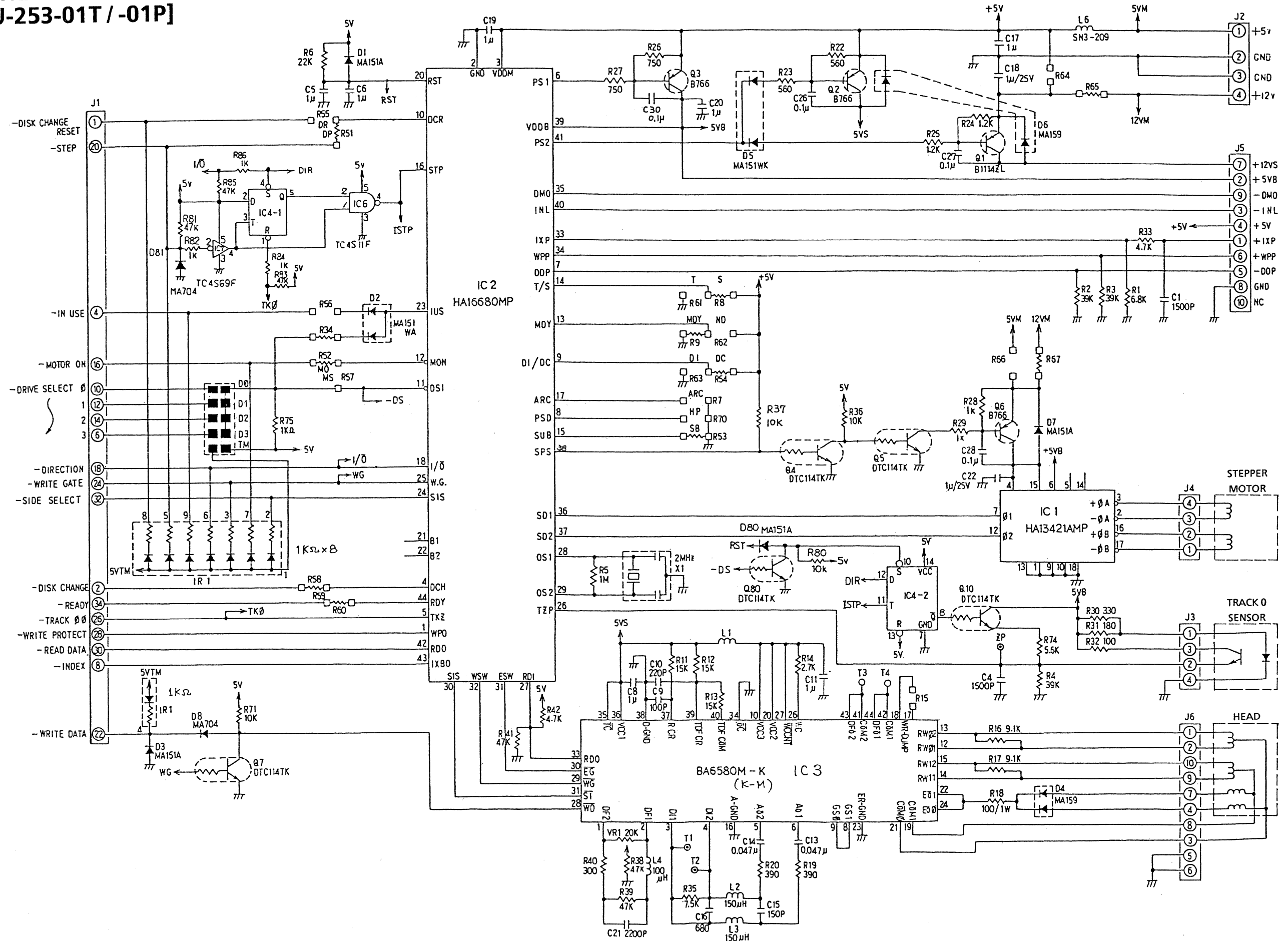

SCHEMATIC DIAGRAM OF CONTROL BOARD [JU-253-01PK]

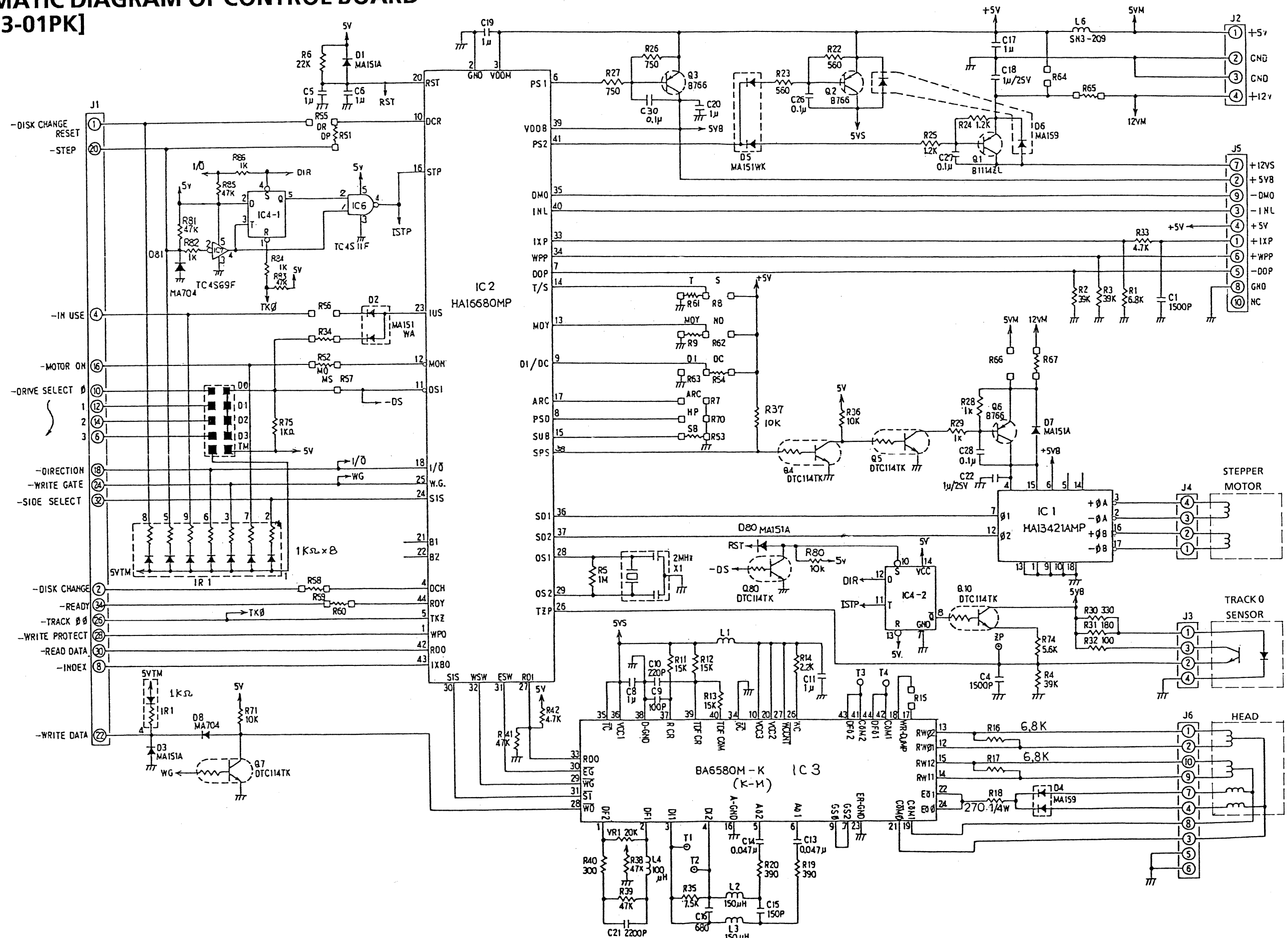

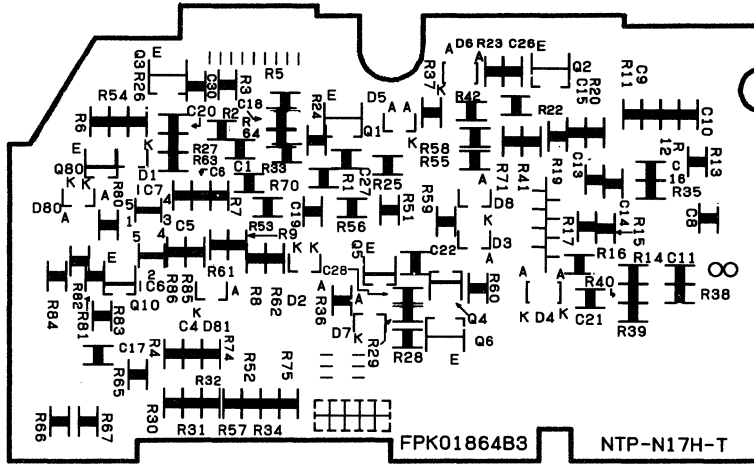

Solder Side (Bottom)

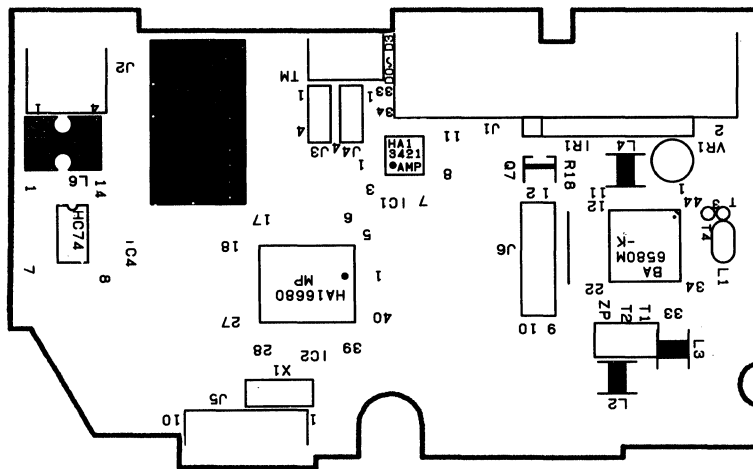

Technical Publications Suggestion Form

We would appreciate your comments and Suggestions for improving this Publication

**Technical
Publications
Suggestion
Form**

PUBLICATION NO:	TITLE:	DATE:
WHAT IS YOUR OVERALL RATING THIS PUBLICATION? <input type="checkbox"/> VERY GOOD <input type="checkbox"/> FAIR <input type="checkbox"/> VERY POOR <input type="checkbox"/> GOOD <input type="checkbox"/> POOR		
IS THE MATERIAL PRESENTED EFFECTIVELY? <input type="checkbox"/> WELL ORGANIZED <input type="checkbox"/> FULLY COVERED <input type="checkbox"/> CLEAR <input type="checkbox"/> CORRECT <input type="checkbox"/> WELL ILLUSTRATED		

Panasonic

COMMENTS:

PLEASE PRINT: NAME, ADDRESS AND PHONE NO.

PLEASE MAIL TO: _____

Matsushita Communication Industrial Co., Ltd.
Memory Systems Division
3-1, 4-chome, Tsunashima-Higashi
Kohoku-ku, Yokohama 223 JAPAN