

KS10-BASED DECSYSTEM-2020 INSTALLATION MANUAL

Preliminary, October 1978
First Edition, September 1979

Copyright © 1979 by Digital Equipment Corporation

The material in this manual is for informational purposes and is subject to change without notice.

Digital Equipment Corporation assumes no responsibility for any errors which may appear in this manual.

Printed in U.S.A.

This document was set on DIGITAL's DECset-8000 computerized typesetting system.

The following are trademarks of Digital Equipment Corporation, Maynard, Massachusetts:

DIGITAL	DECsystem-10	MASSBUS
DEC	DECSYSTEM-20	OMNIBUS
PDP	DIBOL	OS/8
DECUS	EDUSYSTEM	RSTS
UNIBUS	VAX	RSX
	VMS	IAS

CONTENTS

Page

CHAPTER 1	INTRODUCTION	
CHAPTER 2	PLANNING DECSYSTEM-2020 INSTALLATION	
2.1	INTRODUCTION.....	2-1
2.2	PERSONNEL	2-1
2.3	SCHEDULING.....	2-1
2.4	PREREQUISITES AND ASSUMPTIONS.....	2-1
2.5	SYSTEM INSTALLATION AND CHECKOUT TIMEFRAME.....	2-3
2.6	SYSTEM SPARES	2-3
CHAPTER 3	UNPACKING AND INSPECTION	
3.1	SHIPPING AREA PROCEDURES.....	3-1
3.2	REQUIRED TOOLS.....	3-1
3.3	SEALED CONTAINERS	3-6
3.4	PACKING LIST	3-6
3.5	SHIPPING DAMAGES.....	3-6
3.6	OPENING SHIPPING CONTAINERS.....	3-7
3.7	INVENTORY	3-7
3.8	EXTERNAL DAMAGE INSPECTION	3-7
3.9	MISSING PARTS PROCEDURES	3-7
3.9.1	Short Shipment Procedure.....	3-9
3.9.2	Non-Short-Shipment Missing Items.....	3-10
3.10	COMPLETION	3-10
3.11	SHIPMENTS DAMAGED IN TRANSMIT.....	3-11
3.12	RETURNING DAMAGED EQUIPMENT	3-11
3.13	SUMMARY.....	3-11
CHAPTER 4	UNIT PLACEMENT AND SYSTEM INTERCONNECTION	
4.1	EQUIPMENT MOVEMENT.....	4-1
4.2	KS10 (2020) CABINET HANDLING	4-1
4.3	DESKIDDING EQUIPMENT	4-1
4.3.1	Deskidding the KS10-A and DNHXX-A (KS10 Style Cabinets)	4-1
4.3.2	Deskidding the CR04 Card Reader.....	4-5
4.3.3	Deskidding the LP14/05 Line Printer	4-5
4.3.4	Deskidding the RM03 Disk Drive.....	4-5
4.3.5	Deskidding the RP06 Disk Drive	4-6
4.3.6	Deskidding the TU45 Magtape Drive	4-6
4.4	EQUIPMENT POSITIONING	4-6
4.5	LEVELING FEET	4-6
4.6	INSPECTION	4-7
4.7	COMPONENT CHECKS	4-7
4.8	FASTENER CHECKS.....	4-7
4.9	CABLING CHECKS	4-8
4.10	BACKPLANE CHECKS	4-8
4.11	SYSTEM CABLES.....	4-8

CONTENTS (Cont)

	Page
4.12	CABLE INSTALLATION4-9
4.12.1	RP06 Cable Installation.....4-9
4.12.2	RM03 Cable Installation4-11
4.12.3	TU45 Cable Installation4-11
4.12.4	LP20 Cabling.....4-14
4.12.5	LA36 CTY Cables4-14
4.12.6	CR04 (DNHXX-A) Installation and Cabling.....4-16
4.12.7	Communication Cables4-20
4.12.8	DUP11 No. 1 and 2 Synchronous Communications.....4-20
4.12.9	Remote Diagnosis Cable.....4-20
CHAPTER 5	POWER CHECKOUT
5.1	PREPOWER CHECKOUT.....5-1
5.1.1	Customer Voltage Checks.....5-1
5.1.2	Checking Ground Wires5-1
5.1.3	Power Control.....5-6
5.1.4	Switch Panel.....5-6
5.1.5	Peripheral Drawer (BA11K).....5-6
5.1.6	Logic Power Wiring.....5-8
5.2	POWER UP CHECKOUT5-9
5.3	VOLTAGE CHECKS AND ADJUSTMENTS5-10
5.3.1	KS10 PA Backplane5-10
5.3.2	BA11-K Backplane.....5-12
5.3.3	Peripherals5-12
5.3.4	Conclusion5-12
5.4	DNHXX-A PREPOWER CHECKOUT5-13
5.4.1	BA11K Prepower Checkout.....5-13
5.4.2	BA11K Power Wiring.....5-14
5.5	DNHXX-A POWER-UP CHECKOUT5-14
5.5.1	861C Power Controller5-14
5.5.2	BA11-K Power Up Checkout5-14
CHAPTER 6	STANDARD SYSTEM CHECKOUT PROCEDURES
6.1	INTRODUCTION.....6-1
6.2	TEST EQUIPMENT6-1
6.3	TEST SOFTWARE6-1
6.3.1	System Loaders and Monitors6-1
6.3.2	KS10 CPU Functional Processor Diagnostics.....6-1
6.3.3	Memory Diagnostics6-6
6.3.4	Mass Storage and Communications and Hard Copy Device Diagnostics6-6
6.4	PHASE A - 8080 CONSOLE TESTING.....6-7
6.4.1	LA36.....6-7
6.4.2	Power On6-7
6.4.3	Master Reset6-7
6.4.4	Lamp Test.....6-8
6.4.5	KS10 Bus Operations6-8
6.4.6	Memory Operations6-8
6.4.7	I/O Operations.....6-8

CONTENTS (Cont)

		Page
6.4.8	Fault Detection	6-8
6.4.9	CRAM Operation	6-8
6.4.10	Remote Link	6-9
6.5	PHASE B - LOADING DIAGNOSTICS AND MICROCODE.....	6-13
6.5.1	Loading Diagnostics from Disk	6-13
6.5.2	Loading Diagnostics from Magtape.....	6-13
6.6	PHASE C - CPU CHECKOUT	6-14
6.6.1	Quick Verify CPU Functional Diagnostic String (SMCPU)	6-14
6.6.2	Instruction Timing Test	6-14
6.7	PHASE D - MEMORY CHECKOUT	6-14
6.7.1	Overnight CPU/Memory Reliability Run.....	6-14
6.8	PHASE E - MASS STORAGE DEVICE CHECKOUT	6-19
6.8.1	Disk Subsystem Checkout	6-19
6.8.2	Disk Overnight Reliability	6-19
6.8.3	Magtape Subsystem Checkout.....	6-20
6.9	PHASE F - COMMUNICATIONS AND HARDCOPY DEVICE CHECKOUT	6-32
6.9.1	LA36 Terminal Diagnostic (DSLTA).....	6-32
6.9.2	LP20/LP14/LP05 Line Printer Checkout	6-32
6.9.3	CR04 Card Reader	6-33
6.9.4	Asynchronous Communications Checkout	6-33
6.9.5	Synchronous Communications Checkout	6-33

CHAPTER 7 REPORTING PROCEDURES

7.1	INTRODUCTION.....	7-1
7.2	LARS REPORT FORM.....	7-1
7.3	DECSYSTEM-2020 INSTALLATION REPORT	7-3
7.4	DAILY LOG	7-3
7.5	LCG INSTALLATION WARRANTY COSTS SUMMARY FORM.....	7-4
7.6	INSTALLATION/ACCEPTANCE REPORT.....	7-6

FIGURES

Figure No.	Title	Page
2-1	Installation Planning Sheet.....	2-2
3-1	Unpacking and Inspection Flow.....	3-2
3-2	Installation Short Shipment Procedures Flow.....	3-8
4-1	Unit Placement and System Interconnection Flow.....	4-2
4-2	Unit Movement.....	4-4
4-3	Leveling Foot Detail	4-6
4-4	Massbus Transition Plate	4-9
4-5	RP06 Massbus Connector	4-10
4-6	RM03 Massbus Connector	4-12
4-7	TU45 Massbus Connector	4-13
4-8	MTA (Magnetic Tape Adapter).....	4-15
4-9	BA11-K Drawer (DNHXX Cabinet), MUL	4-16

FIGURES (Cont)

		Page
4-10	DNHXX Cabinet (Rear View – Skins Removed)	4-17
4-11	CR04 Card Reader	4-18
4-12	Communication Cable Panel	4-19
5-1	Power Checkout Flow	5-2
5-2	DECSYSTEM-2020 Cabinet (Rear)	5-5
5-3	861 Power Controller	5-6
5-4	BA11K Backplane (KS10 Cabinet).....	5-7
5-5	H7130 Power Supply	5-8
5-6	Power Distribution Board	5-10
5-7	KS10 Backplane	5-11
5-8	Power Tab and Adjustment Locations (DNHXX Cabinet)	5-13
6-1	System Diagnostic Checkout	6-2
7-1	LARS Report Form	7-2
7-2	LCG Installation Warranty Costs Summary Form	7-5
7-3	DECSYSTEM-2020 Installation Report	7-7

TABLES

Table No.	Title	Page
5-1	KS10 Short Checks	5-8
5-2	BA11-K Short Checks	5-9
5-3	KS10 Voltage Requirements.....	5-10
5-4	BA11-K Voltage Requirements	5-12
5-5	DNHXX-A/BA11-K Short Checks.....	5-14
5-6	DNHXX-A/BA11-K Voltage Requirements.....	5-14

CHAPTER 1 INTRODUCTION

The installation procedures contained in this manual provide system check-out and acceptance for the DECSYSTEM-2020. Adherence to these procedures ensures that both the system and configuration conform to design specifications. Where applicable, flow diagrams complement specific procedures and appear at the beginning of each chapter. Personnel involvement, schedules, customer data, prerequisite assumptions, daily installation breakdowns, and sparring is contained in Chapter 2.

Unpacking and inspection procedures, Chapter 3, ensure that the proper system has been received at the customer site, and all equipment has arrived in good physical condition. Chapter 3 also contains unit placement information dealing with transporting the equipment from the loading dock to the site location and the (deskidding) procedures to be followed.

Unit interconnection procedures in Chapter 4 provide installation and interconnection information for the DECSYSTEM-2020. Included are: system positioning and grounding, cable identification, and sequence of installation and routing.

Chapter 5 contains power check-out procedures required to verify that the power system is functioning properly.

Total system operation is checked via the standard system checkout procedures in Chapter 6.

Reporting procedures such as LARS forms, installation reports, and daily logs are detailed in Chapter 7.

CHAPTER 2

PLANNING DECSYSTEM-2020 INSTALLATION

2.1 INTRODUCTION

A critical factor in the pre-installation phase is to develop an installation plan agreeable to all parties concerned prior to system delivery.

This chapter outlines personnel involvement, timescales, customer data, prerequisite assumptions, and a daily hardware installation breakdown. An example of an installation planning sheet is shown in Figure 2-1.

2.2 PERSONNEL

The DIGITAL personnel involved in the complete installation and acceptance plan are listed below and should be consulted prior to the customer receiving such a plan.

1. Account Sales Representative
2. Software Representative
3. Field Service Account Supervisor/Manager
4. Field Service Account Representative
5. Field Service/Regional Support

2.3 SCHEDULING

The appropriate time to generate the installation plan is approximately 30 days prior to delivery. This is close enough to installation time for people/resource commitments to be made and lessens the chance of circumstances changing.

2.4 PREREQUISITES AND ASSUMPTIONS

1. Hardware installation team available.
2. A stable and clean environment as follows:
 - a. Power: 120/240 V \pm 6%-13%
 - b. Frequency: 50/60 Hz \pm 1 Hz
 - c. Temperature: 18°-24° C (65°-75° F) max rate of change 2° C/Hr (3.6° F/Hr)
 - d. Humidity: 40-60% max rate of change 2%/Hr
3. Work period (8 hours per day).
4. System Contents
 - a. Disk Drive (1)
 - b. Tape Drive (1)
 - c. Line Printer (1)
 - d. Communication Lines (16)

Add 3 hours to total installation time for each additional unit.

5. Modem installed for remote diagnosis.
6. System layout has been determined.
7. Pre-Installation Site Survey completed.

INSTALLATION PLANNING SHEET

CUSTOMER: _____
SALESPERSON: _____
INSTALLATION SUPERVISOR: _____
INSTALLATION TEAM: _____
TEAM LEADER: _____
WORKING HRS/DAY: _____
CUSTOMER CONTACT: _____
SITE PHONE: _____
SOFTWARE SPECIALIST: _____
CUSTOMER ACCEPTANCE CRITERIA: (STANDARD) (SPECIAL)

EQUIPMENT BEING INSTALLED:

PERSON RESPONSIBLE TO UNLOAD SYSTEM AND PLACE IN COMPUTER ROOM:

MR-1951

Figure 2-1 Installation Planning Sheet

2.5 SYSTEM INSTALLATION AND CHECKOUT TIMEFRAME

Day 1

1. Unpacking
2. Inventory
3. Exterior and interior QC inspection

Day 2

1. Cabinet positioning
2. Cabinets bolted (if necessary)
3. Cable installation
4. Pre-power checkout

Day 3

1. Power-on check and adjustments
2. Peripheral off-line checks and adjustments
3. Front End (8080) check
4. Remote link check
5. KS10 CPU/memory diagnostic checkout
6. Overnight CPU/memory reliability run

Day 4

1. Mass storage device diagnostic check
2. Overnight disk reliability
3. Communications and hard copy device checkout

Day 5

1. Monitor load and acceptance run
2. SYSERROR Analysis
3. Handover to software personnel

2.6 SYSTEM SPARES

For systems which are geographically remote or isolated from repair/replacement facilities, a spare parts checkout program should be considered prior to hardware acceptance. A quick go/no go, dead-on-arrival check extends installation time approximately one day. Following checkout, it is required that all spare modules be removed from the system and the originals replaced prior to hardware acceptance.

When a spare parts checkout program is to be performed, care should be taken to tag all modules to be tested or removed. The sequence of insertion should be planned prior to starting the test. An appropriate time to cycle spares is after all diagnostic checkout procedures have been completed; i.e., following day 5 of the day-by-day installation plan (Paragraph 2.5).

A suitable sequence of diagnostics should be run after each module/module batch insertion. The particular sequence will depend on which part of the system contains the spares being checked.

NOTE

Ensure the Installation/Acceptance Report has been filled out properly.

CHAPTER 3 UNPACKING AND INSPECTION

3.1 SHIPPING AREA PROCEDURES (Refer to Figure 3-1.)

Because of dock or shipping area procedures and/or ease of performing inventory, the shipment may be moved from the customer's shipping area to the computer area. If so, follow the moving procedures in Paragraphs 4.2 and 4.3 (Chapter 4) and then continue with Paragraph 3.2.

3.2 REQUIRED TOOLS

The tools required to deskid and install a DECSYSTEM-2020 computer system are listed below.

1. Basic tool kit (7606864)

DEC Part Number	Description
29-13456	Nut driver set
29-13457	Adjustable wrench
29-13460	Diagonal cutting pliers (95ELH-EREM)
29-13462	Miniature needle nose (UTICAB5317)
29-13463	Pliers, 6-1/2 inch
29-12573	Ratchet offset screwdriver
29-13466	Utility knife (Xacto No. 51ST)
29-13467	Wire strippers
29-13468	4-inch \pm 5/16-inch screwdriver
29-13470	No. 0 Phillips screwdriver
29-13471	Trimpot screwdriver
29-13472	No. 2 Phillips screwdriver
29-13474	6-inch round smooth cut file
29-10779	6-inch half-round smooth cut file
29-13515	Thickness gauge set
29-13451	Solder pullit
29-10780	Pen light
29-13461	Needle nose pliers
29-12574	Phillips stubby screwdriver
29-13459	Allen wrench set
29-12559	Tweezers, No. 151392
29-12575	Valve spout oiler No. 990034
29-12567	Service case

DECSYSTEM-2020 INSTALLATION FLOW

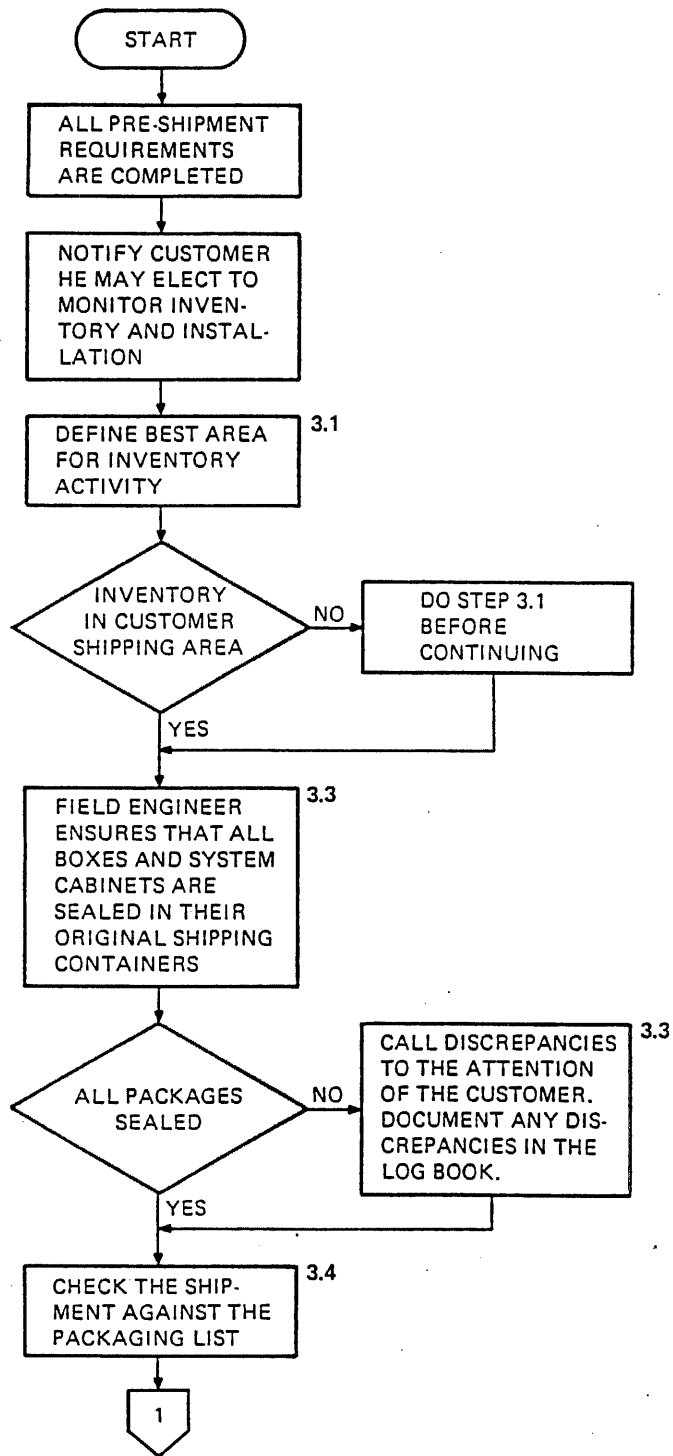

MR 1952

Figure 3-1 Unpacking and Inspection Flow (Sheet 1 of 4)

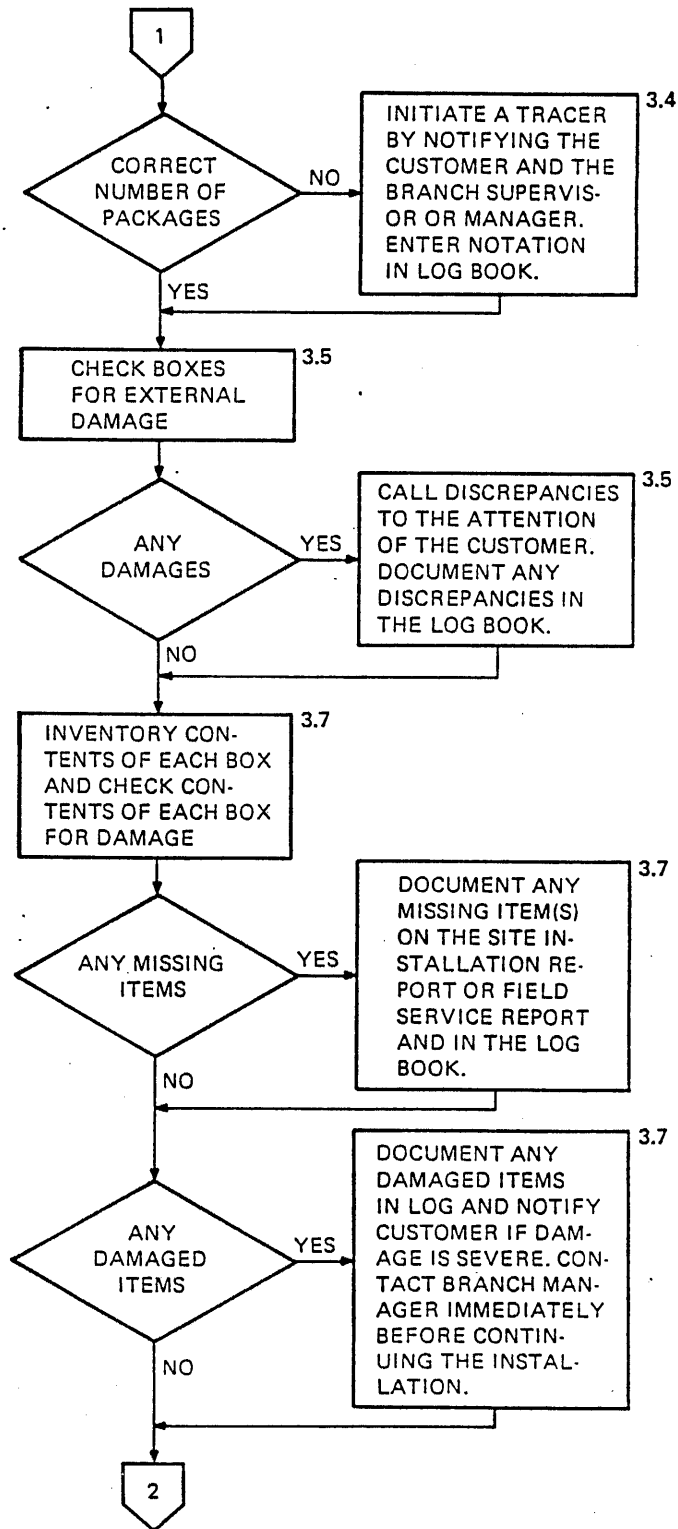

MR 1953

Figure 3-1 Unpacking and Inspection Flow (Sheet 2 of 4)

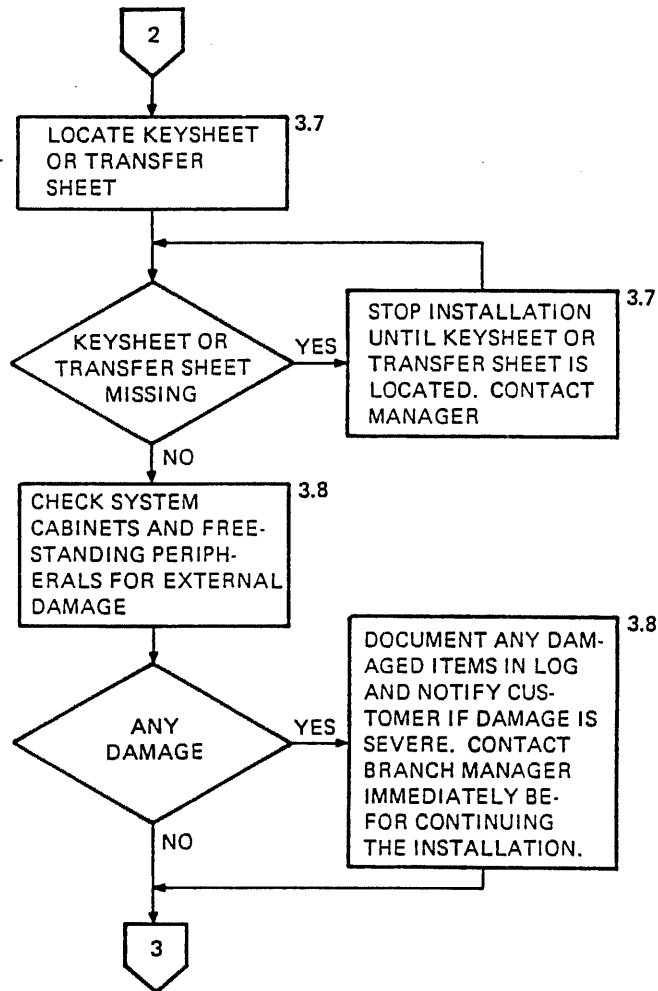

MR 1954

Figure 3-1 Unpacking and Inspection Flow (Sheet 3 of 4)

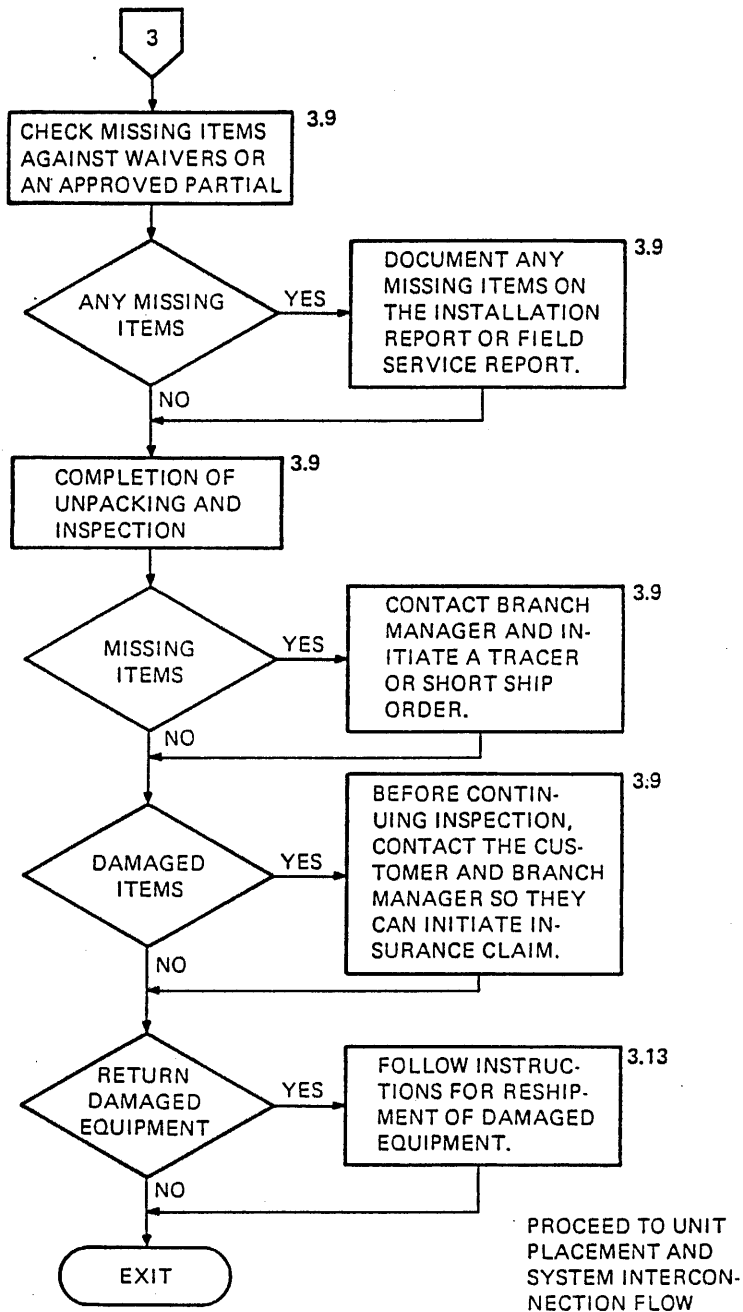

MR 1955

Figure 3-1 Unpacking and Inspection Flow (Sheet 4 of 4)

2. Additional tools required

DEC Part Number	Description
29-12529	Screw holder
29-12577	Miniature combination wrench set
29-13452	Soldering iron
29-19333	Soldering iron tip
29-13512	Burnishing blade
29-13513	Unwrapping tool - 24 gauge
29-18387	Unwrapping tool - 30 gauge
29-13450	Handwrap tool - 24 gauge
29-18301	Handwrap tool - 30 gauge
29-10246	IC clips (2)
	Large adjustable wrench
	Hammer
29-13455	Crimping tool for "fast-on" connectors
	Tightening tool for "fast-on" connectors
	1/4-inch drive ratchet and socket set and level
	Oscilloscope (Tektronix 475)
	Digital voltmeter
	C.O.M. microfiche reader
	Microfiche library
	RM03 or RP06 perch tester
	Scratch magtapes
	Scratch disks
	DZ11 and DUP11 wraparound plugs (H325, H3271, or H3190)
	RED PACK
	Diagnostic tape (DSXLA)

3.3 SEALED CONTAINERS

Ensure that all boxes are sealed and that system cabinets and free-standing peripherals are in their shipping containers, which should be unopened. If anything is opened, call it to the attention of the customer and document it on the installation report or field service report.

3.4 PACKING LIST

Check the shipment against the packing list to ensure that the correct number of packages has been received. If an incorrect number of packages has been delivered notify the customer and the Branch Service Manager (BSM) or the Branch Supervisor (BS). The customer should check with the carrier to locate the missing package(s) and have the missing package(s) delivered to the site. The BSM or BS may have to check with the traffic and shipping departments to locate missing packages if the carrier does not have them.

3.5 SHIPPING DAMAGES

Check all boxes for external damage. Inspect for dents, protrusions, holes, smashed corners and pins, etc. If any boxes are damaged, notify the customer and document it on the installation report or field service report.

3.6 OPENING SHIPPING CONTAINERS

Open the box with the red label marked READ ME FIRST and locate its packing slip. Inventory each box against the packing slip and note any missing items on the installation report or field service report. While performing inventory, inspect each item for damage. Note damaged items on the installation report or field service report and inform the customer immediately. If the damage is extensive, call the Branch Service Manager immediately and report the damage.

3.7 INVENTORY

NOTE

If the keysheet is missing, stop the installation and call the Branch Service Manager to locate the keysheet or transfer sheet.

Documentation is provided in the customer envelope to allow the customer and the field service person to answer the following inventory questions.

1. Have all the cartons and boxes been received?

Using the shipper's waybill, the number of containers should be counted to ensure that none were lost in shipment. If any are missing, the shipper should institute a trace or insurance claim at the customer's request.

2. Are all of the options which the customer ordered present?

Using the Actual Cost Jobs Closes or Transfers sheet, the system configuration should be inventoried for correct content and quantities of options. This form indicates what was ordered from the manufacturing group.

3. Are all the accessories which should accompany the options and system present?

Using the accessory shipping lists, count and check every item contained in the boxes.

NOTE

Check the customer's envelope for waiver forms which indicate that items have been backordered and will be shipped separately. Do not order waived or partial items as short shipped.

If all items and parts have been received, inform the customer and continue with the installation.

3.8 EXTERNAL DAMAGE INSPECTION

Check the system cabinets and free-standing peripherals for external damage to the shipping skid, covers, etc. Inspect the shipping containers for signs of stress or abusive handling. Remove the polyethylene covers and inspect external surfaces for scratches, holes, broken switches, broken panels, dented end panels, broken stabilizer feet, and any other damage or sign of abusive handling during shipment.

3.9 MISSING PARTS PROCEDURES

This section defines an order short shipment, and the procedures for processing a short shipment P1 request through Field Service Logistics. It also outlines the procedures to follow when a missing item situation other than a "short shipment" is encountered, with the responsibilities identified for each organization. An overview of a short shipment is presented in the flowchart in Figure 3-2.

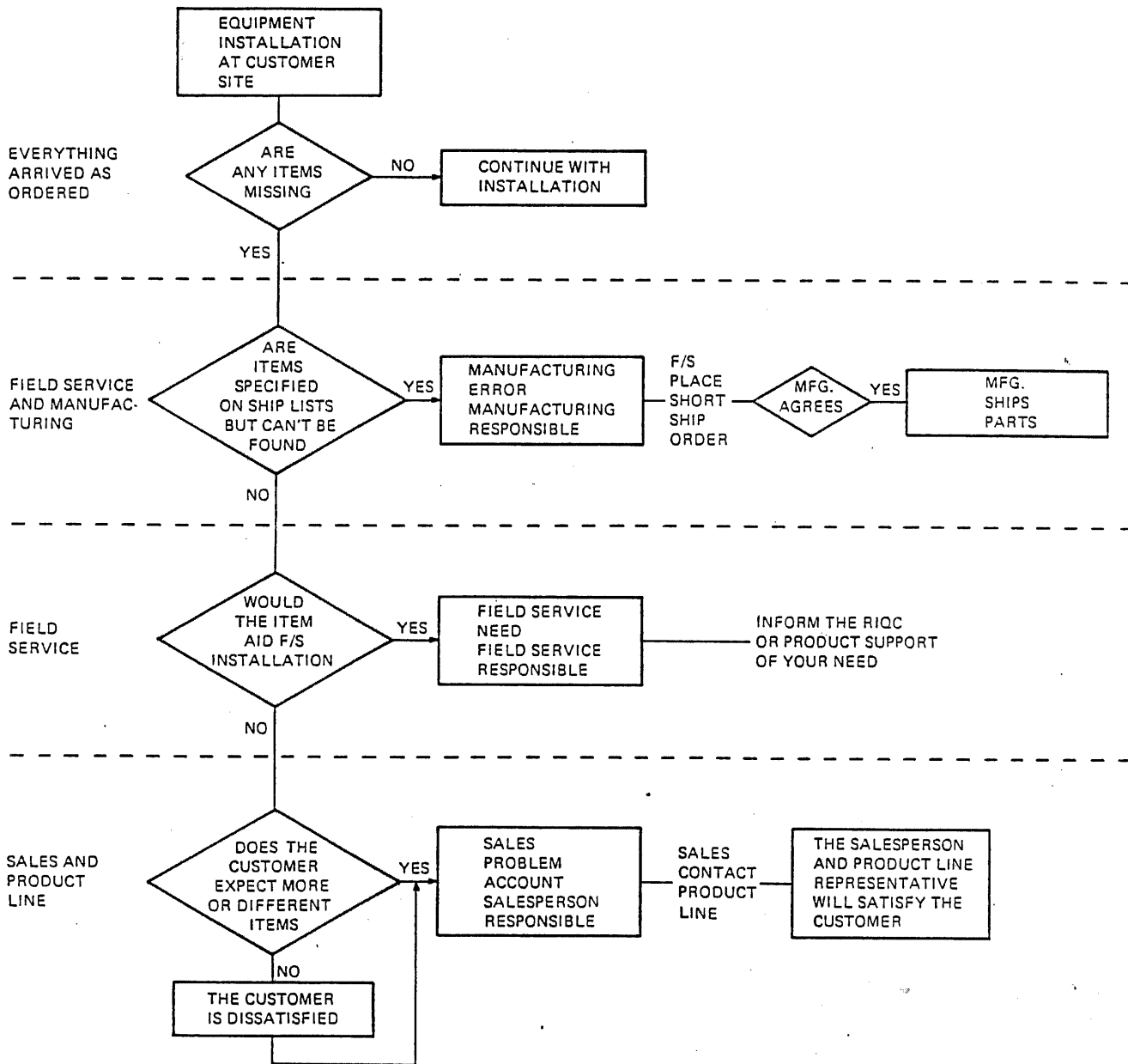

MR.1956

Figure 3-2 Installation Short Shipment Procedures Flow

A short shipment is an item or items identified on the shipping document as required to ship with the order, but which inventory shows to be missing from the shipment. Paragraph 3.9.1 describes the procedures to follow in case of short shipment.

If a required item is missing and is not listed on one of the shipping documents as having been shipped or as required to ship, proceed to Paragraph 3.9.2.

NOTE

If the customer is performing the installation and finds material missing, then the customer should directly contact the account salesperson with the list of missing parts.

3.9.1 Short Shipment Procedure

If an item is listed on one of the shipping documents as required to ship but it cannot be found when the installation inventory is performed, it is short shipped.

Contact the branch logistics administrator and provide the following information.

1. DEC Number
2. System Type
3. Customer Name
4. Product Line
5. System Serial Number
6. Part Number(s)
7. Part Description
8. Quantity

The branch logistics administrator will then assign an SBA number to the request and TWX it to the regional logistics center with the following additional information.

1. The branch office contact name and location
2. The SBA Number
3. Branch DECNET code

NOTE

When the materials requested are low cost and readily available in the branch or regional stockroom, they should be used and the Short Ship P1 should be filled at that point. The materials used should then be charged to the installation activity and product line. The intent is to ensure that the customer will be serviced efficiently.

The regional logistics center should check their stock upon receipt of the Short Ship P1 request as noted above. If parts cannot be released due to cost or availability, retransmit the TWX to the Woburn P1 group immediately.

The Woburn P1 group will log the Short Ship request, and TWX directly to the responsible Manufacturing Short Ship Coordinator, as listed by manufacturing, within two hours of receipt. Each manufacturing group in each plant has a designated coordinator in their facility who will receive the Short Ship request from Woburn. The manufacturing coordinator will verify the request. The responsibilities of the Field Service Short Ship Coordinator, from this point, will be to monitor and log the status of the request as received from manufacturing until the SBA has been closed.

If the Manufacturing Short Ship Coordinator needs additional information, they will TWX questions directly to the requesting branch, with a copy going to the Field Service Coordinator in Woburn for logging. A response from the branch should go directly to the individual requesting the information in manufacturing within 24 hours. When the branch responds, the request will resume processing.

The Manufacturing Short Ship Coordinator will check the request against the manufacturing records. If it is determined that the request is not valid a TWX will be sent to the branch rejecting the order with the reason why it is being rejected. A copy of the TWX will also be sent to the Logistics Coordinator who will then close the SBA. Appeals (when deemed necessary by the Branch Service Manager) should go directly to the person sending the rejection TWX if there was miscommunication, or to the account salesperson for Product Line or customer resolution.

If the request is valid, the Manufacturing Short Ship Coordinator will TWX the PI request status directly to the branch with a copy to the Logistics Coordinator, giving parts availability and an estimated time of arrival. If the parts will not be readily available within two days, the Manufacturing Coordinator will make the appropriate contact with the Product Line to authorize other priority acquisition procedures. In any case, status of the Short Ship PI request should be sent by the Manufacturing Coordinator directly to the branch contact within 24 hours of manufacturing receipt of the request.

3.9.2 Non-Short-Shipment Missing Items

The installing field person should provide the service manager or supervisor with the details of the problem encountered. It should be made clear that this is not a short shipment but that it prevents continuation or completion of the installation or customer acceptance.

Having collected the complete information, the Branch Service Manager should work with the customer's account salesperson to determine if the item requested is a service aid or may be customer required. A *service aid* is an item or tool that Field Service could use to improve the installation or checkout process. This information should be documented and sent to the proper support supervisor or the Regional Installation Quality Coordinator.

If the item is required by the customer, the account salesperson for the customer will gather all the appropriate details and contact the appropriate product line representative. The product line representative will check the details and respond within *24 hours* directly to the salesperson with their findings and the actions that they will take and the time when it will be done. It is the salesperson's responsibility to notify the service manager and the customer of the information received.

The product line representative will arrange directly with manufacturing for all materials to be prioritized, scheduled and shipped if it is determined to be the obligation of DIGITAL or in the best interest of the customer.

3.10 COMPLETION

This completes the unpacking and inspection phase. Documentation of the entire system should be intact at this time. Notify the Branch Service Manager or Branch Supervisor of any discrepancies noted during this phase.

If discrepancies such as damage do exist, the Branch Supervisor may want the customer to initiate an insurance claim. For missing items, the Branch Service Manager or Branch Supervisor should initiate a short ship request. All the problems should be discussed with the Branch Service Manager or Branch Supervisor.

Customer claims on damaged equipment may be difficult to obtain if the equipment in question has been removed from the skid. Therefore, if any damage exists, the damaged equipment should not be deskidded or moved until authorized by the Branch Service Manager. The customer is responsible for payment of the replacement or repair of damaged equipment. This arrangement will be discussed between the customer and the Branch Service Manager. If damaged equipment is to be returned to Digital Equipment Corporation, the procedures in Paragraph 3.12 should be followed.

3.11 SHIPMENTS DAMAGED IN TRANSIT

This problem is documented in the *Field Service Procedures Manual*, Chapter 1, Paragraph 1.13. Refer your supervisor/manager to this chapter whenever a damage situation arises.

3.12 RETURNING DAMAGED EQUIPMENT

Any piece of equipment to be shipped to Digital Equipment Corporation, as a return authorization from the field, must be transported on a proper skid or in the container in which it was shipped. If the equipment has been removed from a skid and it is not available, a replacement must be ordered from Maynard Traffic or Stockroom 17.

Skids may also be manufactured in the locality of the customer site.

Part of the customer's upgrade contract is that the customer is liable for all rigging and transportation charges; therefore, the customer may be billed for the skids and associated hardware.

A sample of various devices is listed below, along with the respective skid part numbers.

Options	Skid Part No
RM03	12-10568-1
RP06	12-10568-2
LA36	9405651
LP20-A,B	12-10568-5

When a return authorization has been validated by DIGITAL and a skid has been procured, the procedure for loading a piece of equipment for reshipment to DIGITAL is as follows.

1. Remove the end panels and front and rear outer doors.
2. Raise the leveler feet.
3. Carefully place the equipment on skids.
4. Tighten the shipping bolts and lower the leveler feet. Also, lower any stabilizer feet levelers (if applicable).
5. Check to be sure that all shipping brackets for sliding chassis are in place and all module hold-down bars are secured.
6. Replace all end panels and doors, securing the doors with door holders.
7. Crate the cabinet appropriately; i.e., use a polyethylene bag, corrugated wrap-around, etc.

3.13 SUMMARY

Documentation of the entire system should be completed at this time and all discrepancies should be known and under control. Customer claims on damaged equipment may be difficult to obtain if the equipment in question has been *removed from a skid*. Therefore, any piece of equipment that is to have damage claims *should not be deskidded* since the customer is responsible for payment of replacement or repair. This arrangement will be discussed between the customer and the Branch Service Manager. When damages exist, the system *should not be deskidded* or moved until authorized by the Branch Service Manager.

CHAPTER 4 UNIT PLACEMENT AND SYSTEM INTERCONNECTION

4.1 EQUIPMENT MOVEMENT

See Figure 4-1. Move all boxes to the computer area. If inventory is complete, properly store the documentation (e.g., prints, manuals, diagnostics, write-ups, etc.) in the storage facility – preferably a cabinet with shelves. (A storage cabinet is usually supplied by the local field service branch.) This facilitates a smoother and more organized installation and eliminates hunting for prints, manuals, or diagnostics in the various boxes.

4.2 KS10 (2020) CABINET HANDLING

See Figure 4-2. Obtain the site layout sheet from the customer. Also, obtain the configuration sheet; some product lines include it in the shipping documentation. Move the system cabinets to the computer area.

The following recommendations for handling the cabinets should be followed.

1. At least two workers are required to handle each cabinet.
2. When the cabinet is to be pushed over steps (steel ramp over steps), riggers may be hired.
3. While loading or unloading a cabinet on a ramp, a “come-along” (a type of block and tackle) should be used to prevent loss of control over cabinet.
4. When moving cabinets on a smooth inclined plane having a pitch greater than 2.5 cm (1 inch) per foot (such as in corridors, hallways, etc.) or where a cabinet is at rest on an incline plane of less than 3.55 cm (1.4 inch) per foot but when an applied horizontal force of less than 4.53 kg (10 lb) could move or slide the cabinet in either direction, a “J” bar or a “come-along” should be used to control cabinet speed. See Figure 4-2.
5. When moving such a cabinet over any kind of carpet or rough floor, a “roller lift” is required to prevent damage to flooring or equipment. See Figure 4-2.
6. If the cabinet is to be pulled over steps, or greater than 0.635 cm (1/4 inch) gaps or crevices between buildings, partitions, etc., a flat steel plate or ramp should be used.
7. Fork lifting the cabinet can be accomplished if forks are inserted as shown in Figure 4-2.

4.3 DESKIDDING EQUIPMENT

4.3.1 Deskidding the KS10-A and DNHXX-A (KS10 Style Cabinets)

The KS10 and DNHXX-A are shipped on their own rollers, not on a skid. Carefully cut the straps holding the box to the KS10 or DNHXX-A cabinet and remove the box. Remove the plastic covering from the cabinet.

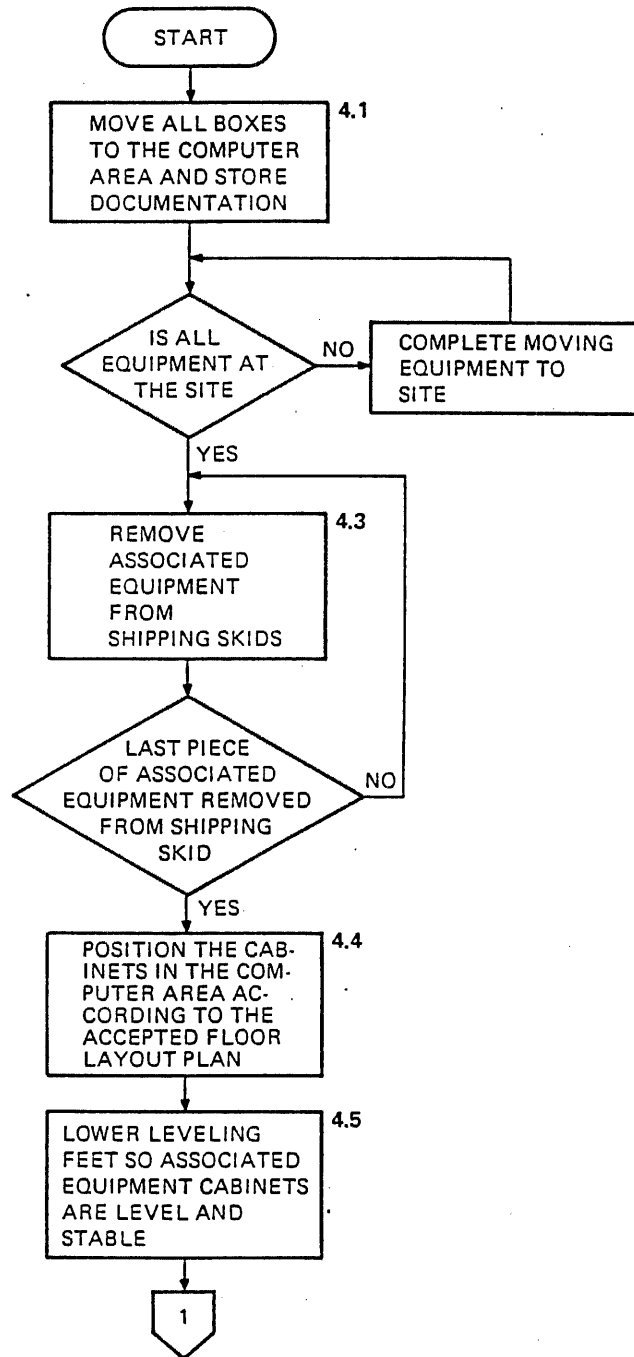

MR-1957

Figure 4-1
 Unit Placement and System Interconnection Flow (Sheet 1 of 2)

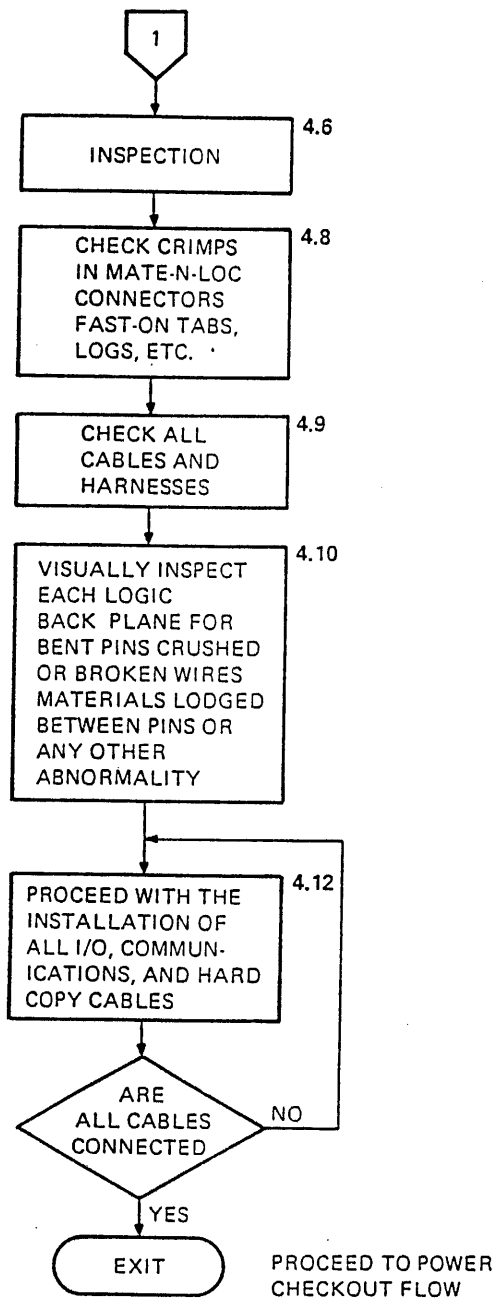

MR 1958

Figure 4-1
Unit Placement and System Interconnection Flow (Sheet 2 of 2)

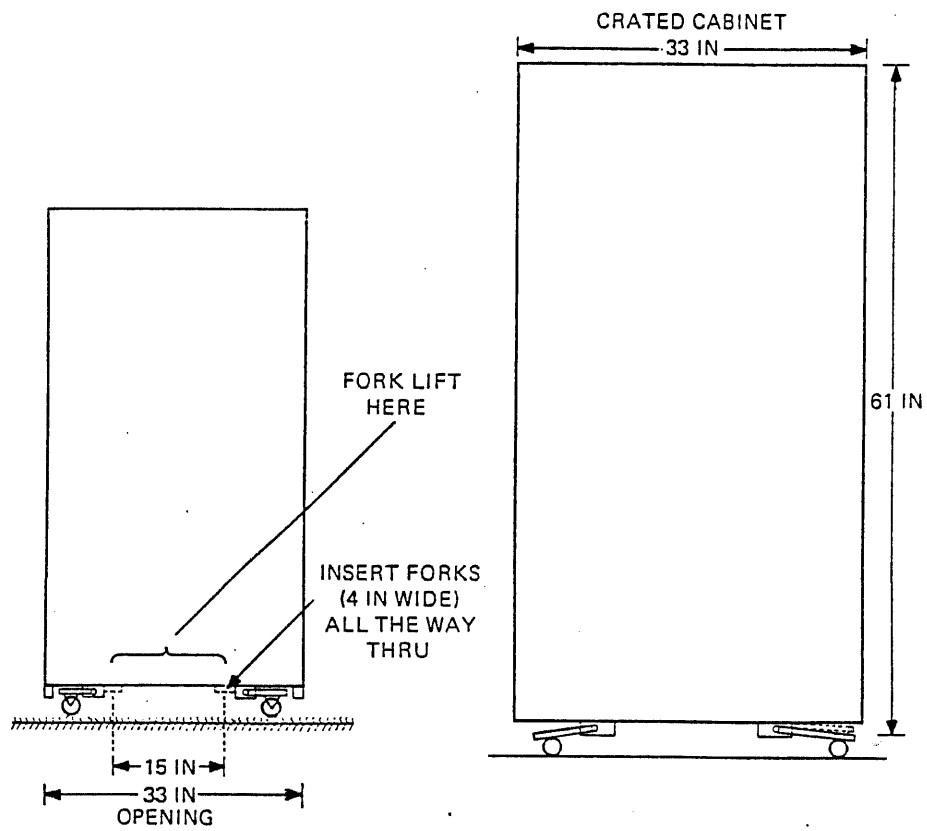
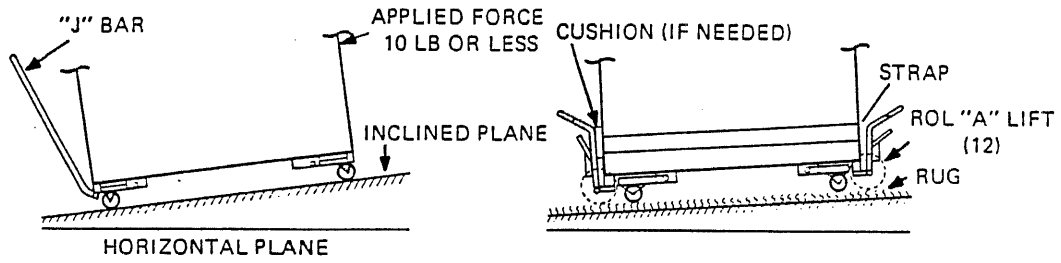

MR-1959

Figure 4-2 Unit Movement

4.3.2 Deskidding the CR04 Card Reader

Carefully cut the straps which hold the covering box and the CR04 to the pallet. Remove the covering. The CR04 is now free to be moved on the pallet.

Slide the CR04 to the edge of the pallet and slowly lower one side of the CR04 to the floor. Tilt the CR04 and remove the pallet.

4.3.3 Deskidding the LP14/05 Line Printer

Carefully remove the staples from the box covering the printer. Remove the box.

Cut and remove the tape from around the base of printer. Remove the paper basket which is shipped at the rear of the printer. The documentation and power stacker, which are shipped inside the front of the printer, must also be removed. Tilt back the top cover. Remove the lower end covers by pulling out at the top of the cover. This will release the magnetic catches. Next, lift up to clear the alignment pins at the bottom.

Remove the four shipping bolts that are through the frame to the pallet. Place the top cover back in its original position.

CAUTION

Do not use the top cover or the printer drum gate as a hand-hold.

Slide the printer forward on the pallet until the front edge of the base can be lowered to the floor. Tilt the printer slightly forward and slide the pallet out from underneath. With the printer on the floor, reinstall the lower end covers.

Install the paper basket on the rear of the printer using the four screws already in place.

NOTE

The top right screw has a star washer for attaching the ground strap which is already on the printer frame.

Unpack the power stacker and remove the four screws holding it to the plywood shipping board. Remove the four screws holding the end plates in place. Using the four screws supplied with the power stacker, attach the stacker to the back of the printer, and plug in the stacker guide.

Discard the small U-shaped part with two screws. This part is a ground clamp (for use with a special cable) not used by DIGITAL.

4.3.4 Deskidding the RM03 Disk Drive

Carefully cut the straps holding the box to the pallet and remove the box. Cut the straps holding the plastic cover over the RM03 and remove the cover. Remove the side, front, and rear panels to gain access to the bolts holding the drive frame to the pallet.

Loosen the bolts approximately 1.27 cm (1/2 in) on one side of the drive frame. Tilt the drive to the opposite side; retract the rubber feet and mount the casters. Repeat this procedure on the other side.

NOTE

Ensure that all cables are away from the casters.

Remove the shipping blocks from under the frame and remove the bolts. Grasp the rear of the drive and pull the drive until the rear casters set on the floor. Go to the front of the drive, lift slightly and slide the pallet out from underneath the drive.

CAUTION

Ensure that no cables are in the way when sliding the pallet out.

4.3.5 Deskidding the RP06 Disk Drive

The RP06 is shipped on a shipping skid, covered by a cardboard carton. Remove the two plastic straps that hold the disk pack on top of the carton, then remove the disk pack.

Remove the staples that fasten the four wooden slats to the bottom flanges of the cardboard-overlapped carton.

Remove the cardboard-overlapped carton.

After removing the hold-down bolts from the skid, install the leveling feet *before* removing the drive from the skid.

Remove the skid from under the drive.

4.3.6 Deskidding the TU45 Magtape Drive

The TU45 is shipped in the same manner as the KS10-style cabinets. Refer to the 2020 and DNHXX-A deskidding instructions.

4.4 EQUIPMENT POSITIONING

Refer to Figure 4-2 and Paragraph 4.2. Starting with the KS10 (2020) central processor and extending outward, position all the associated DECSYSTEM-2020 equipment according to the accepted floor layout plan.

4.5 LEVELING FEET

Lower the leveling feet. (See Figure 4-3.) Ensure that all leveling feet are planted firmly on the floor and that the equipment is all kept level.

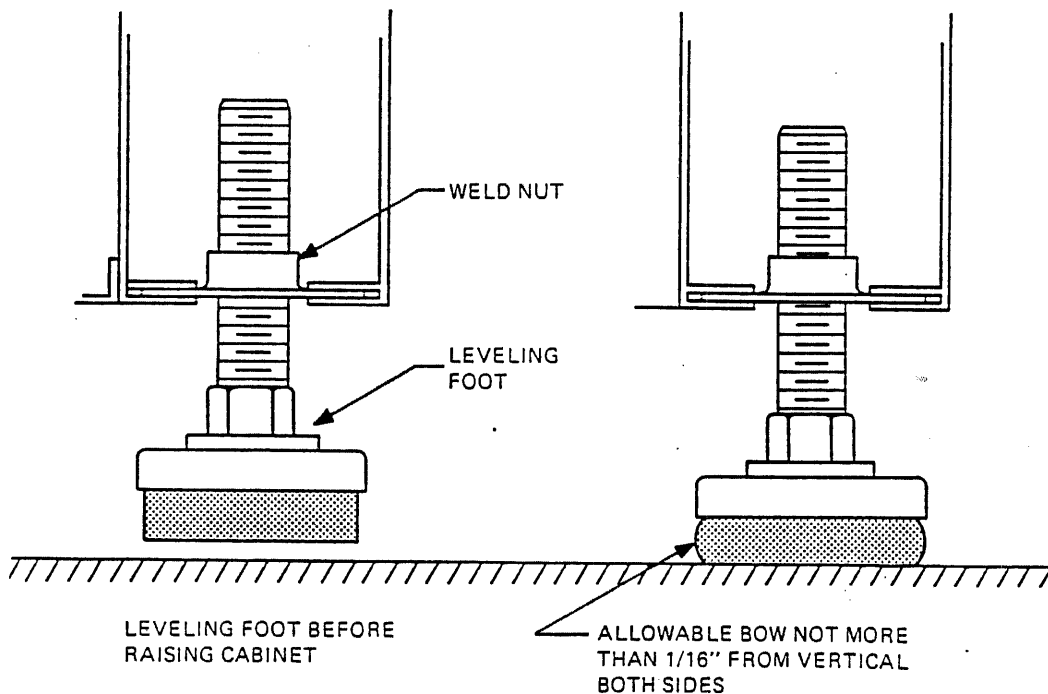

10-2418

Figure 4-3 Leveling Foot Detail

4.6 INSPECTION

NOTE

1. In order to remove the door(s), the door ground wire must first be removed.
2. The stabilizers must be extended in order to free the BA11K.

Inspect each cabinet and free-standing peripheral for internal damage as follows.

1. Remove the tape or plastic shipping pins from the rear access door(s) of the cabinet(s). Remove the door(s) of the cabinet(s) and ensure that each option is secure in the cabinet. Inspect the cabinet for cable damage (ac and dc cables), loose mounting rails, loose fans or blower motors, loose nuts and bolts, screws, loose module clips and module retaining bars, broken switches, lights, breakers, connectors on the power controllers and power supplies, broken cable connectors, console switches, etc.
2. Remove the shipping retainer bolts of each expander chassis, or peripheral on slides, and visually inspect each box and peripheral for damage such as bent pins, loose or broken: modules, switches, lights, or backplanes, etc.

Refer to:

CR04 Manual, EP-CR04K/L-002, Chapter 2
RM03 Manual, EK-RM03-UG-001, Chapter 2
RP06 Manual, ER-00012, Chapter 2
TU45 Manual, EK-TU45A-MM-001, Chapter 2
LP20 Manual, EP-LP20-TM-004, Chapter 2

3. Document any damage and call it to the attention of the customer. If the damage is extensive, report the damage to the Branch Service Manager immediately. DIGITAL is not responsible for shipping damage on systems that are FOB from the manufacturing facility. If reshipping equipment back to DIGITAL is required, follow the instructions listed in Paragraph 3.10.
4. Check each system cabinet and free-standing peripheral to ensure that they contain the items identified on the keysheet or transfer sheet. Also, check the ECO REV level and serial numbers against the keysheet or ECO status sheets. Document any missing items, wrong serial-numbered item, or incorrect revision level item on the installation report or field service report. Ensure that the missing item is not covered by a waiver or an approved partial ship. Also, update the keysheet if ECO status does not appear on it.

4.7 COMPONENT CHECKS

Check each power supply and controller for damage, loose components, loose screws, or extra hardware that may be laying on or lodged into a component board. Check the fans for the supplies to ensure that cables and harnesses are clear of the fan blades and that the fans turn freely.

4.8 FASTENER CHECKS

Check all the crimps that are in all Mate-N-Lok type connectors, fast-on tabs, lugs, etc., for solid connections. This can be accomplished by pulling on the wires. If a lug pulls out, reconnect it to its plug and/or jack. Also, ensure that all connectors are seated properly.

4.9 CABLING CHECKS

Visually check all the cables and harnesses for crushed wires, cut wires, wires smashed together, etc. (especially under logic cabinet door hinges). If any exist, repair or replace the wire(s) or harness. In particular, check ribbon cable connections on UBA, RH11, DZ11, DUP11, LP20 modules, and Mass-bus ribbon cables into the ZIF connectors (located on the interface connector plate at the upper rear of the CPU).

4.10 BACKPLANE CHECKS

Visually inspect each logic backplane (KS10 and BA11-K) for bent pins, crushed or broken wires, foreign material lodged between pins, or any other abnormality.

4.11 SYSTEM CABLES

Refer to the detailed cabling diagram prepared before system delivery, and install the system cables in the order indicated.

NOTES

All cables should be run from point to point, keeping the following in mind.

1. If a false floor does not exist, then all power, ground and system cables should be protected or positioned such that personnel cannot tread upon, trip over, or walk over these cables.
2. All cables (including ground cables) run under the flooring except RP06 and RM03 cables, which run above floor between drives. Refer to the RP06 or RM03 maintenance manual for further information.
3. All cables should be labeled on both ends, stating the device type and the slot numbers where they come from and go to.
4. No signal cables should run parallel with power cables, but should cross them at a 90° angle.
5. Cables should not be drawn tight around cabinet corners or floor posts.
6. If false floor exists ensure that the sub-floor is clean before cables are placed.

4.12 CABLE INSTALLATION

4.12.1 RP06 Cable Installation

Reference should be made to the *Memorex Technical Manual* (677-01/51) for the correct power connection. This is outlined in the installation chapter of the manual.

NOTE

One 3-phase power source may supply up to 2 RP06 disk drives. If additional RP06 disk drives are part of the system, separate power sources must be supplied.

Refer to Figures 4-4 and 4-5.

The BC06S Massbus cable is connected from the Massbus transition plate located at the upper rear of the CPU cabinet to the IN connector block of Port A located beneath the DCL logic box.

If the system has one drive only a Massbus terminator must be connected to the OUT slot of Port A.

For additional drives continue the Massbus cabling from the OUT slot in Port A of Drive 0 to the IN slot of the next drive, using .762 meter (2.5 feet) BC06S cables until the last drive is reached where a Massbus terminator will be installed in the OUT slot of Port A thus terminating the Massbus.

There are several No. 4 gauge (black) ground cables supplied with each system. The ground connection for the RP06 disk drives should be made from the KS10 CPU cabinet to the first drive on the system and then linked from drive to drive. These cables should run in parallel to the Massbus cables. The ground stud can be located on the RP06 beneath the DCL. Ground studs can be located on the base frame of the CPU cabinet.

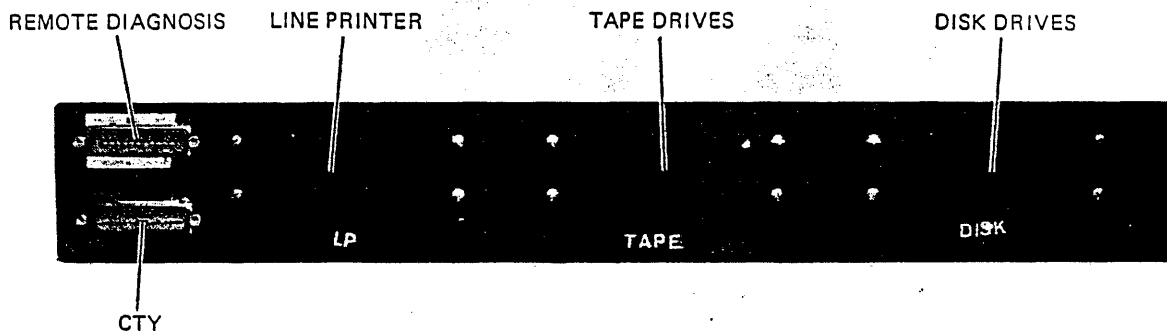

9326-78W-A0281

Figure 4-4 Massbus Transition Plate

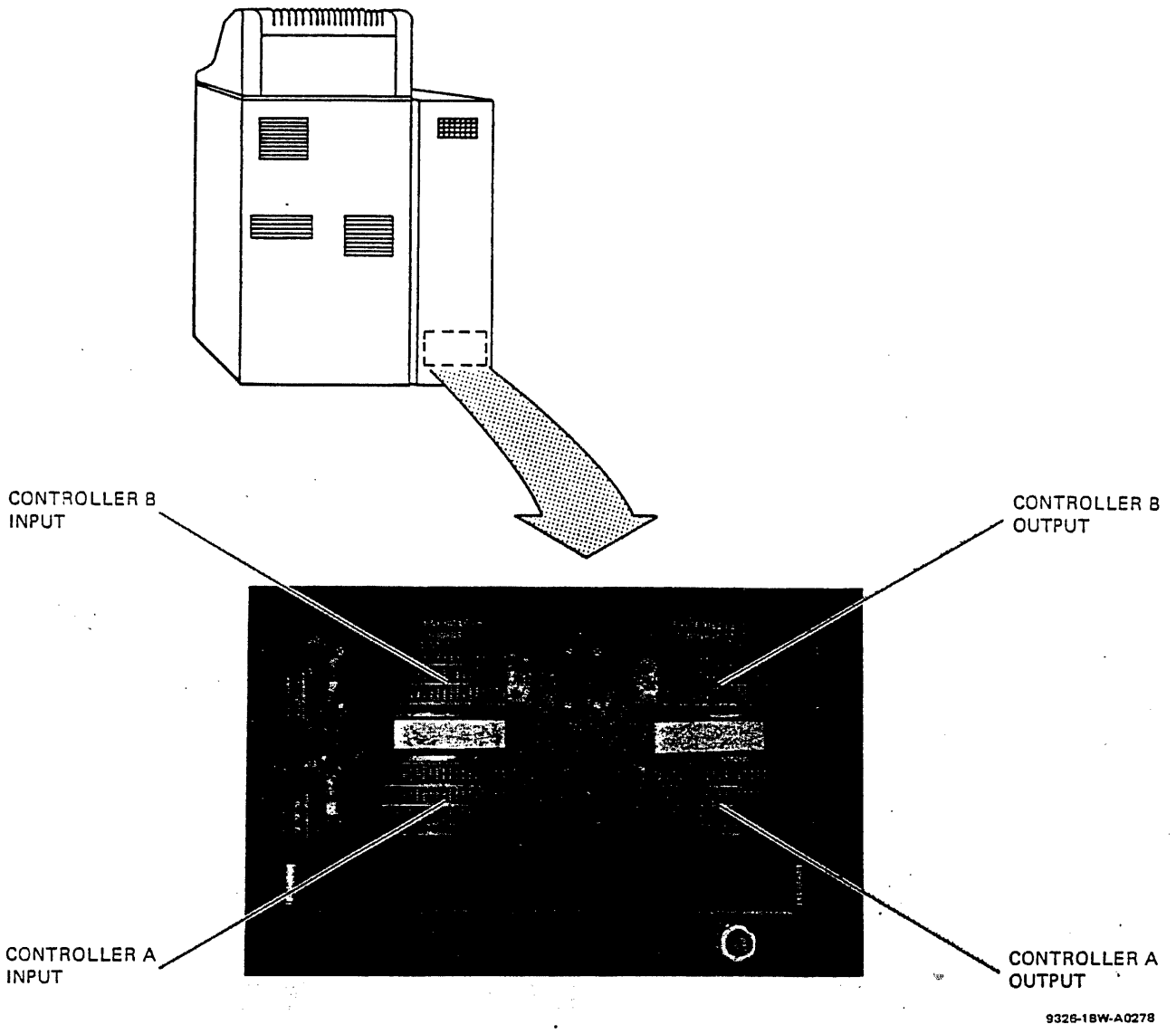

9326-18W-A0278

Figure 4-5 RP06 Massbus Connector

4.12.2 RM03 Cable Installation

Reference should be made to the RM03 drive installation manual for the correct power connection.

NOTES

1. **Ensure the jumper is installed on the MBA backplane between E06E1 and E09C2. If the jumper is not installed, the diagnostics will fail and the drive will not format a pack. The jumper grounds signal BP144 ENB M on page D56 of the MBA printset.**
2. **Each drive should have a separate single phase power source.**

Refer to Figure 4-4 and Figure 4-6.

The BC06S Massbus cable is connected from the Massbus transition plate located at the upper rear of the CPU cabinet to the IN Massbus connector J3 (Port A) of the RM03 located at the front of the MBA logic box. If the system has one drive only, a Massbus terminator must be connected to J2, the OUT connector of Port A located at the rear of the MBA logic box.

For additional drives continue the Massbus cable from the Massbus connector OUT slot J2 in drive 0 to the IN slot, J3 of the next drive using 4.572 m (15 foot) BC06S Massbus cables and terminate the last drive with a Massbus terminator in J2.

There are several No. 4 gauge ground cables supplied with each system. The ground connection for the RM03s should be made from the KS10 CPU cabinet to the first drive on the system and then linked from drive to drive. These cables should run parallel to the Massbus cables. The ground stud for the RM03 and the CPU can be located on the base frame of each cabinet.

4.12.3 TU45 Cable Installation

Refer to the Pertec Service Manual for power connection directions.

NOTE

Each drive should have a separate single phase power source.

Refer to Figure 4-4 and Figure 4-7.

The BC06S Massbus cable is connected from the Massbus transition plate located at the upper rear of the CPU cabinet to the master TU45 drive. This is the drive containing the TM02/3 controller. The Massbus connectors are located on a plate at the bottom of the drive beneath the TM02 controller. Access can be made from the rear of the drive to connect the Massbus. Connect the Massbus terminator to the OUT slot of the Massbus connector.

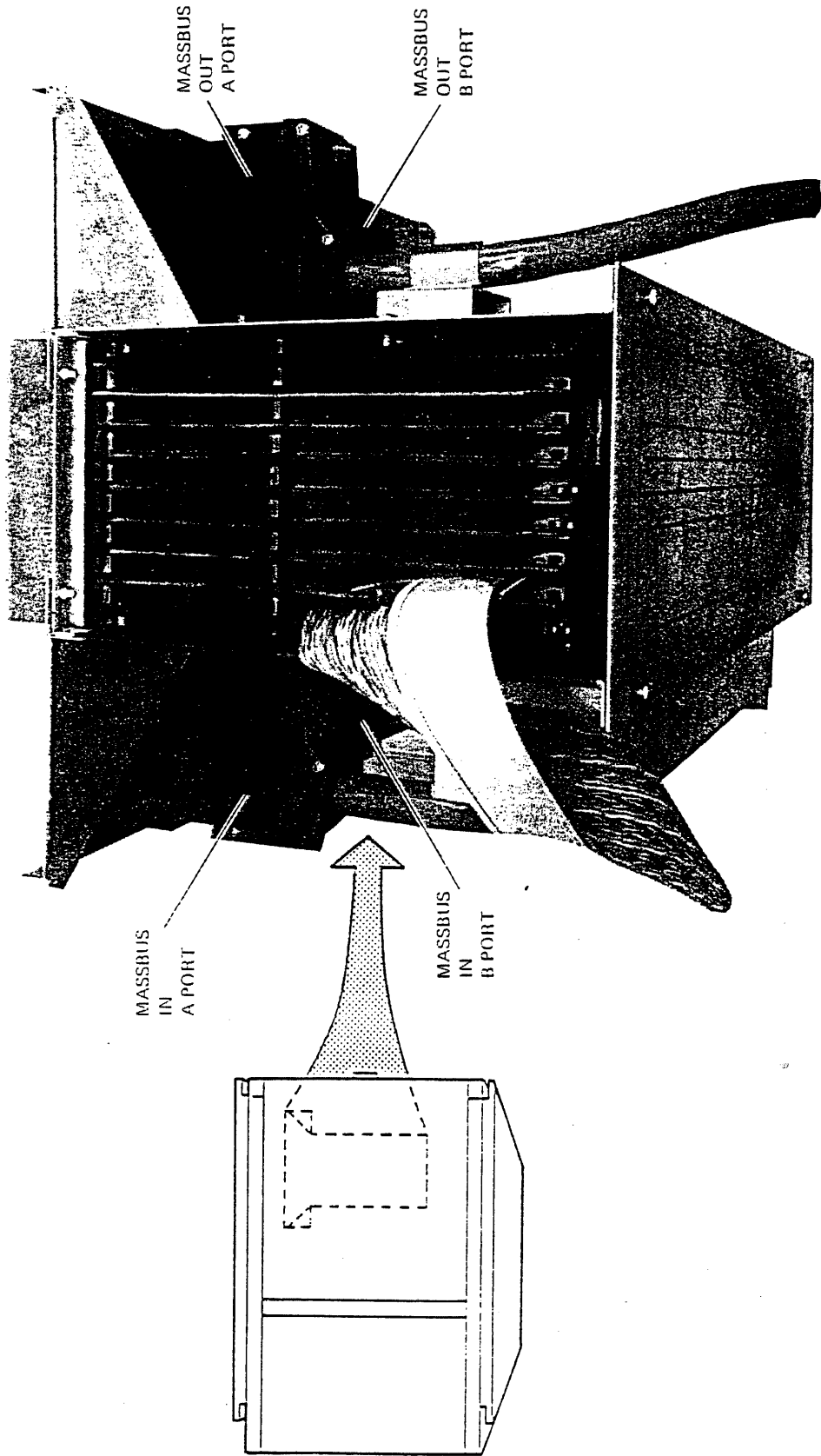

9326-6BW-A0280

Figure 4-6 RM103 Massbus Connector

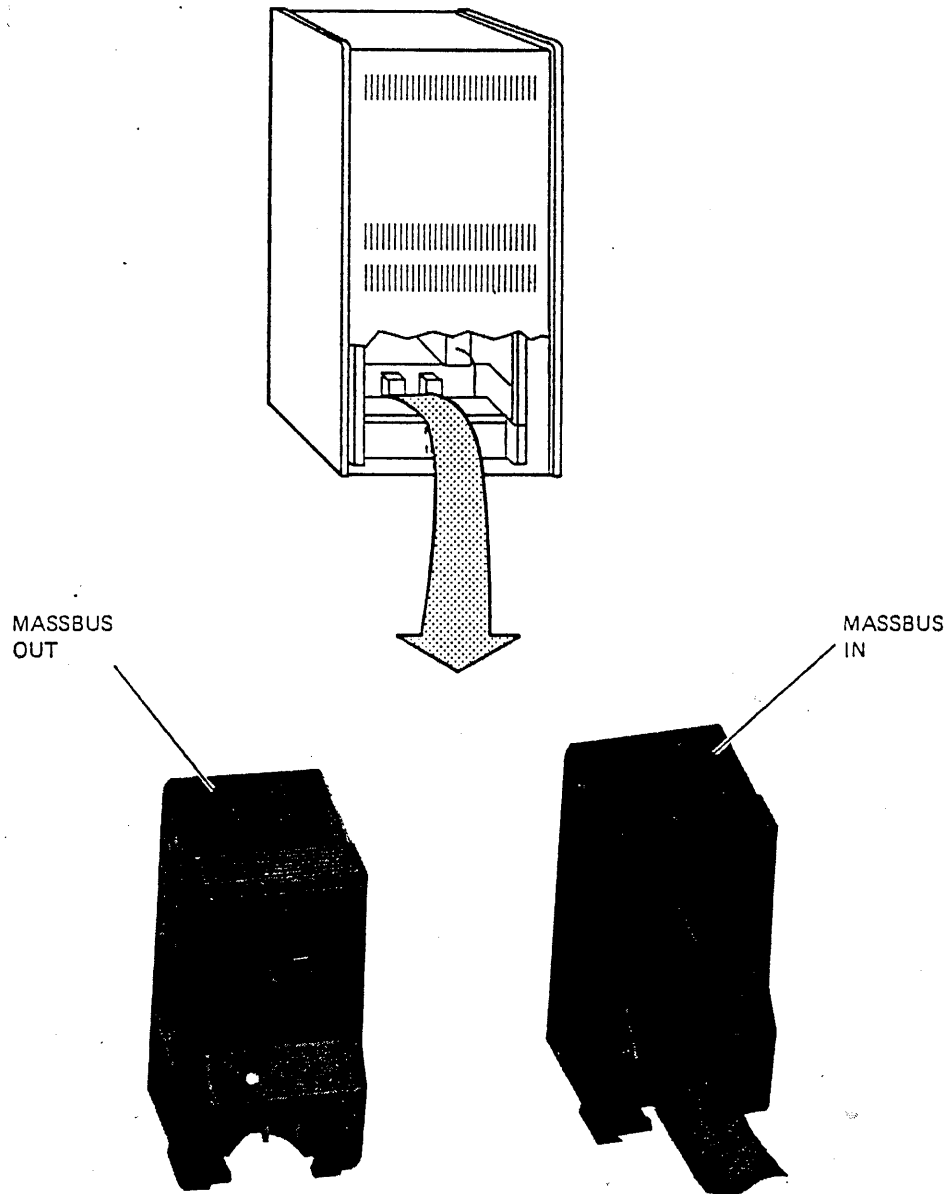

8499-5BW-A0277

Figure 4-7 TU45 Massbus Connector

With more than one drive on the system the slave bus is connected between the MTA boards in each TU45. These connections are as follows. (See Figure 4-8.)

MTA 1st TU45		MTA 2nd TU45
J6	to	SB1
J8	to	SB2
J10	to	SB3

NOTE

These cables have been twisted between output and input; i.e., rough side outermost from the J plugs and smooth side outermost into the SB plugs.

The TU45s must also have a ground connection to the CPU using a No. 4 gauge cable. This cable will run in parallel to the Massbus. The connection is from the ground stud located in the base of the CPU to a ground stud located in the base of the TU45 (master).

Additional TU45s should be bolted together and a braided ground strap used to complete the ground connection.

4.12.4 LP20 Cabling

Refer to Data Products Service Manual for correct power connections. Refer to Figure 4-4.

The LP20 to LP05/14 interface cable is connected from a ZIF connector on the Massbus transition plate located at the upper rear of the CPU cabinet to the LP05/14 connector socket located underneath and to the rear of the LP05/14 printer.

An additional ground connection is not required from the CPU to LP05.

4.12.5 LA36 CTY Cables

Refer to Figure 4-4 and KS10 Mechanical Print Set, Sheet 4.

Connect interface cable to the cinch connector on the Massbus transition plate located at the upper rear of the CPU cabinet.

Connect the power cord to a standard single phase power source.

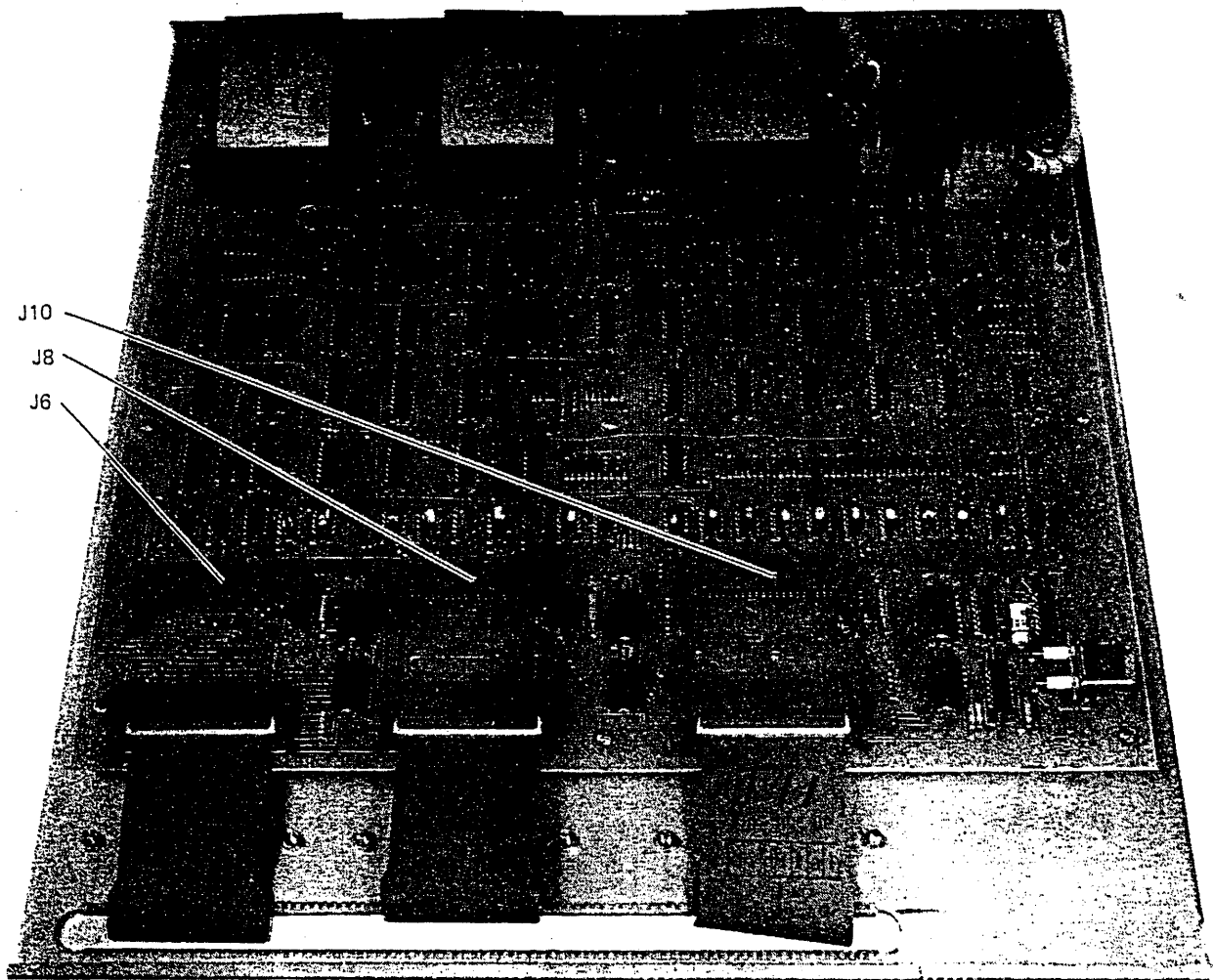

8499-48W-A0278

Figure 4-3 MTA (Magnetic Tape Adapter)

4.12.6 CR04 (DNHXX-A) Installation and Cabling

Refer to Figures 4-9 and 4-10.

Remove the KS10 end panel in order to bolt the DNHXX-AA/AB Expanded Cabinet to the KS10. Mount the end panel removed from the KS10 on the left-hand side of the DNHXX-AA/AB using the same mounting hardware.

Use the BC06S-25 to connect the TU45 to the KS10 if the system has TU45. Return the short BC06S cable (or the long BC06S cable if the system has no TU45) to the factory in Marlboro, MA.

The BC11A-13 cable from the DNHXX-AA/AB is routed to the KS10 BA11-K drawer. The BC11A-13 cable is routed via the cable trough and clamped in the KS10. When the cable has been secured, remove the last system unit installed in the KS10 BA11-K box and insert the BC11A-13 cable.

Install the CR04 Card Reader cable (7008764) between the card reader and Slot B02 of the CD20 controller in the peripheral expander box. (See Figure 4-11.)

Connect single-phase power. Ensure reader is set for correct input voltage.

Run the CD20 diagnostics, if applicable, for a minimum of 12 passes, with one manual intervention pass. Refer to the diagnostic for detailed information. Diagnostic run time will vary depending on the card reader. The Unibus interrupt vector is 230, the address is 777160, and the BR level is 4.

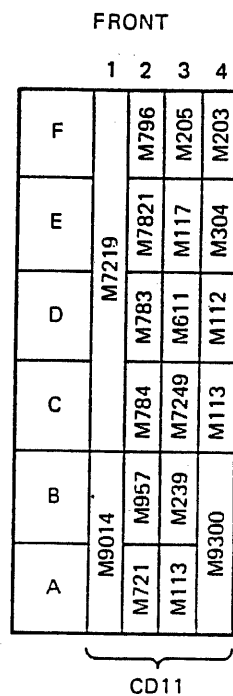

NOTE:
VIEW IS FROM MODULE SIDE.

MR 3318

Figure 4-9 BA11-K Drawer (DNHXX Cabinet), MUL

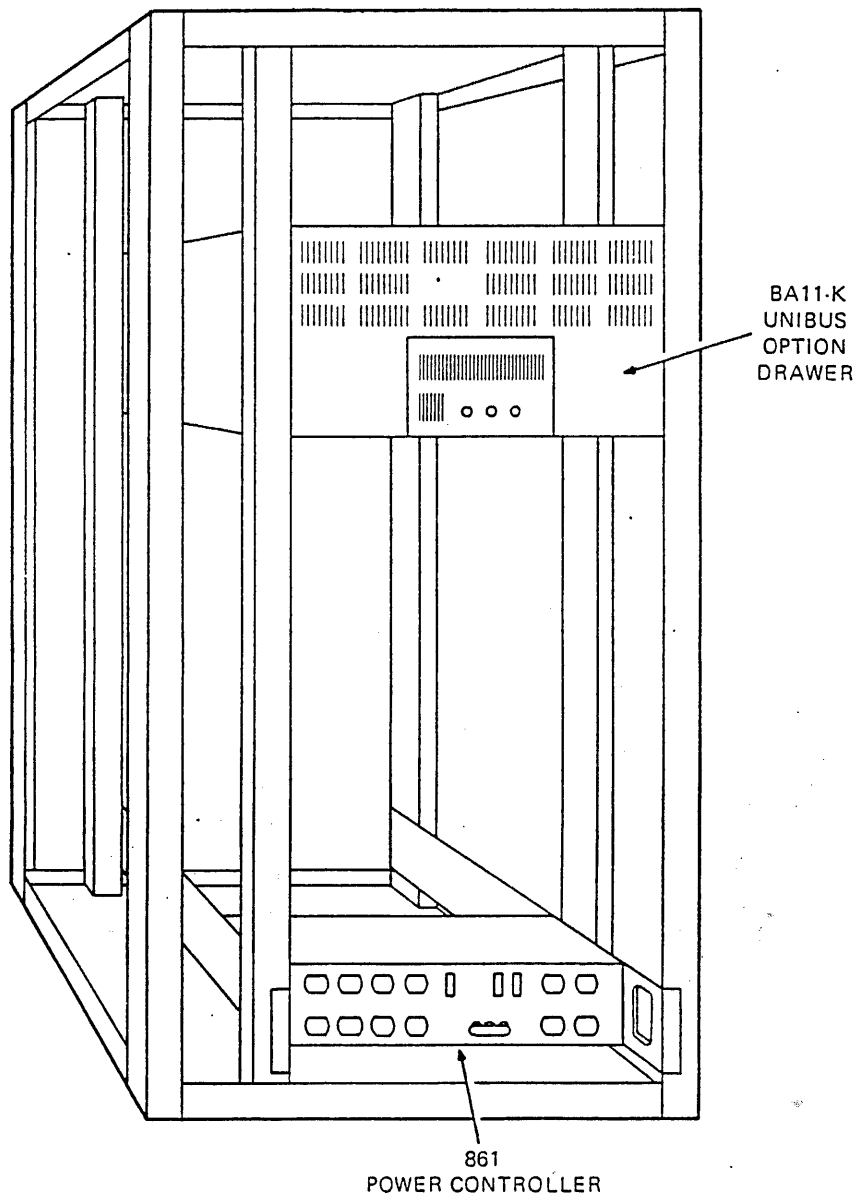
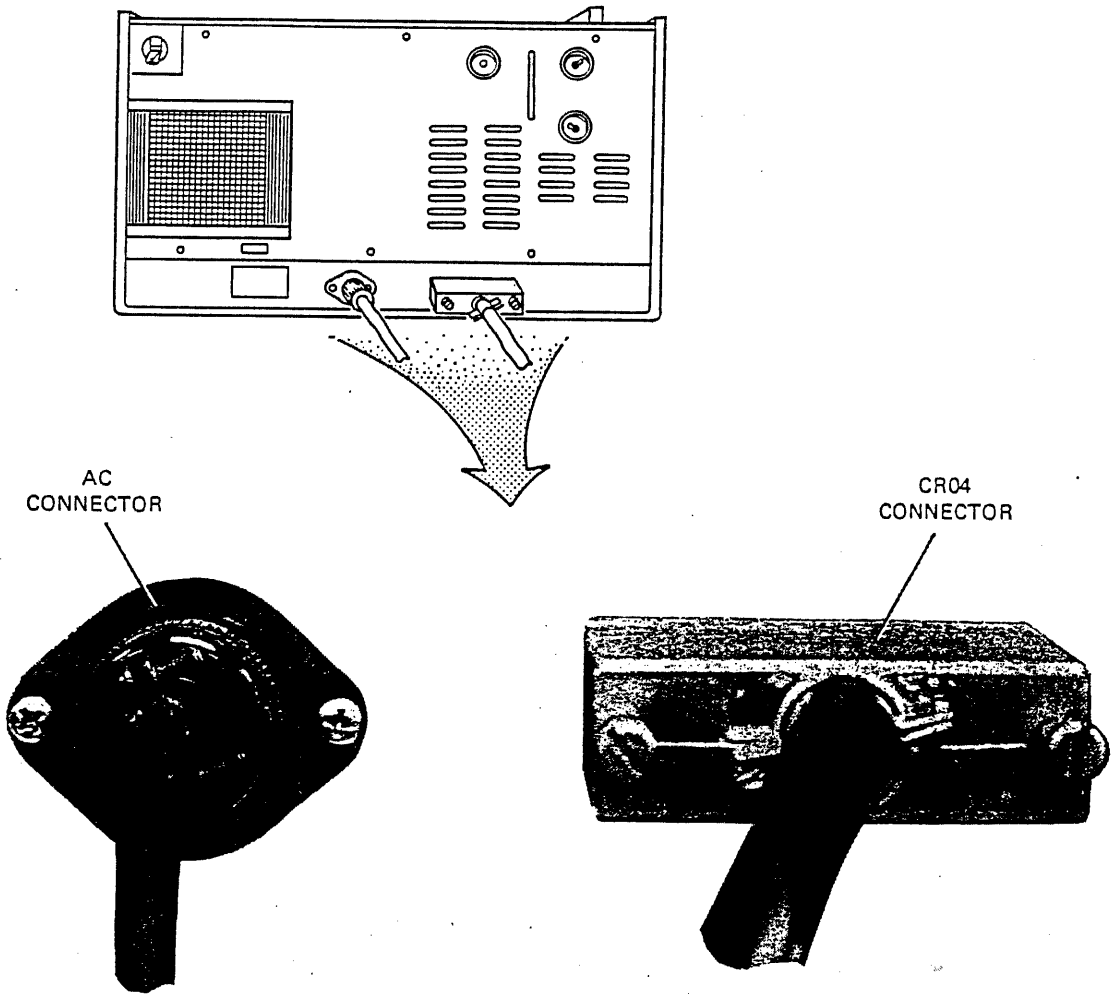
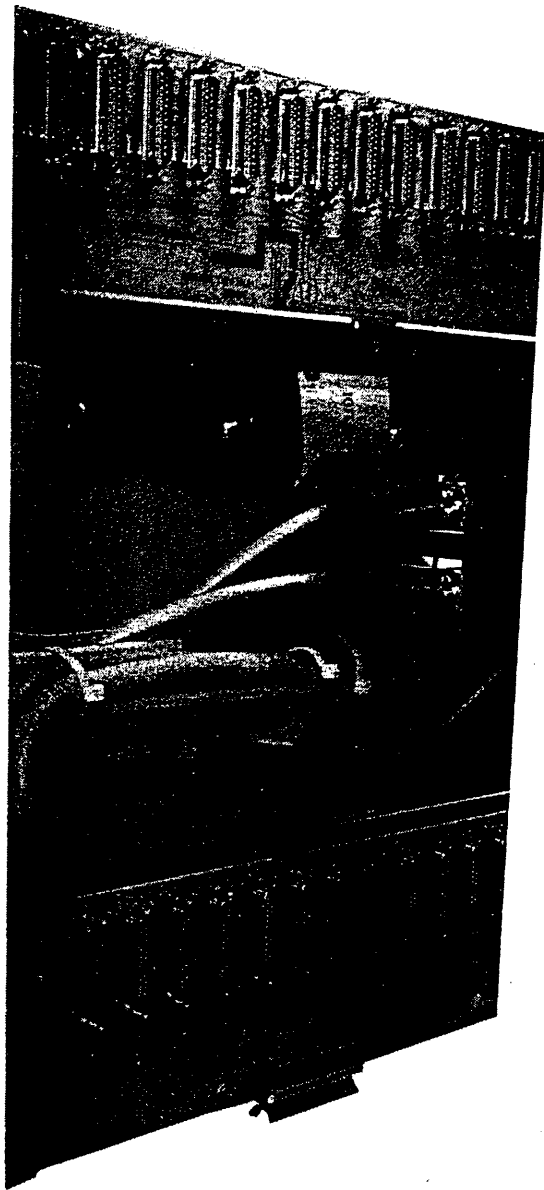

Figure 4-10 DNHXX Cabinet (Rear View - Skins Removed)



9771-88W-A0539

Figure 4-11 CR04 Card Reader



9326-12BW-A0282

Figure 4-12 Communication Cable Panel

4.12.7 Communication Cables

Refer to KS10 FS Print Set, Sheet 4 and Figure 4-12.

Connect the BC05D or BC03M cables to the H317B patch panel located on the right side of the CPU cabinet as viewed from the front. Refer to KS10 Mechanical Drawings for details on dressing these cables.

In many countries, fused barrier boxes are necessary for modem protection. Cables with this type of protection are normally obtained through Computer Special Systems (CSS).

4.12.8 DUP11 No. 1 and 2 Synchronous Communications

These cables will already be dressed in the CPU cabinet and connection should not be needed at the module end. The excess cable will be tied up in the bottom of the CPU cabinet and should be connected to the customer modem.

4.12.9 Remote Diagnosis Cable

See Figure 4-4 and KS10 FS Print Set, Sheet 4.

Route the cable as per sheet 4 of the print set and connect to the cinch connector indicated in Figure 1 on the print set.

NOTE

Ensure the Installation/Acceptance Report has been filled out properly.

CHAPTER 5 POWER CHECKOUT

5.1 PREPOWER CHECKOUT

Perform the following prepower-up procedures. Refer to Figure 5-1 and 5-2.

NOTE

Some emergency power systems are connected to fire alarm systems. If this is true, be sure the proper authorities are notified.

5.1.1 Customer Voltage Checks

Check the customer's ac power for proper voltage, proper phasing, and correctly wired power receptacles. Ensure that the ac ground is connected to all ground pins in all power receptacles for this computer system. Reference the *DECSYSTEM-2020 Site Preparation Guide* (individual option data sheets) for peripheral ac requirements.

After all lines are checked, ensure that all circuit breakers within the power distribution panel are in the OFF position.

WARNING

It is very important that safety ground is obtained throughout the system to minimize the possibility of injury to personnel or damage to the equipment.

5.1.2 Checking Ground Wires

Check all ground wires that connect the system frames. Ensure that the ground lugs make firm contact with the metal on the system cabinet frames (e.g., no paint between wire lugs and frames).

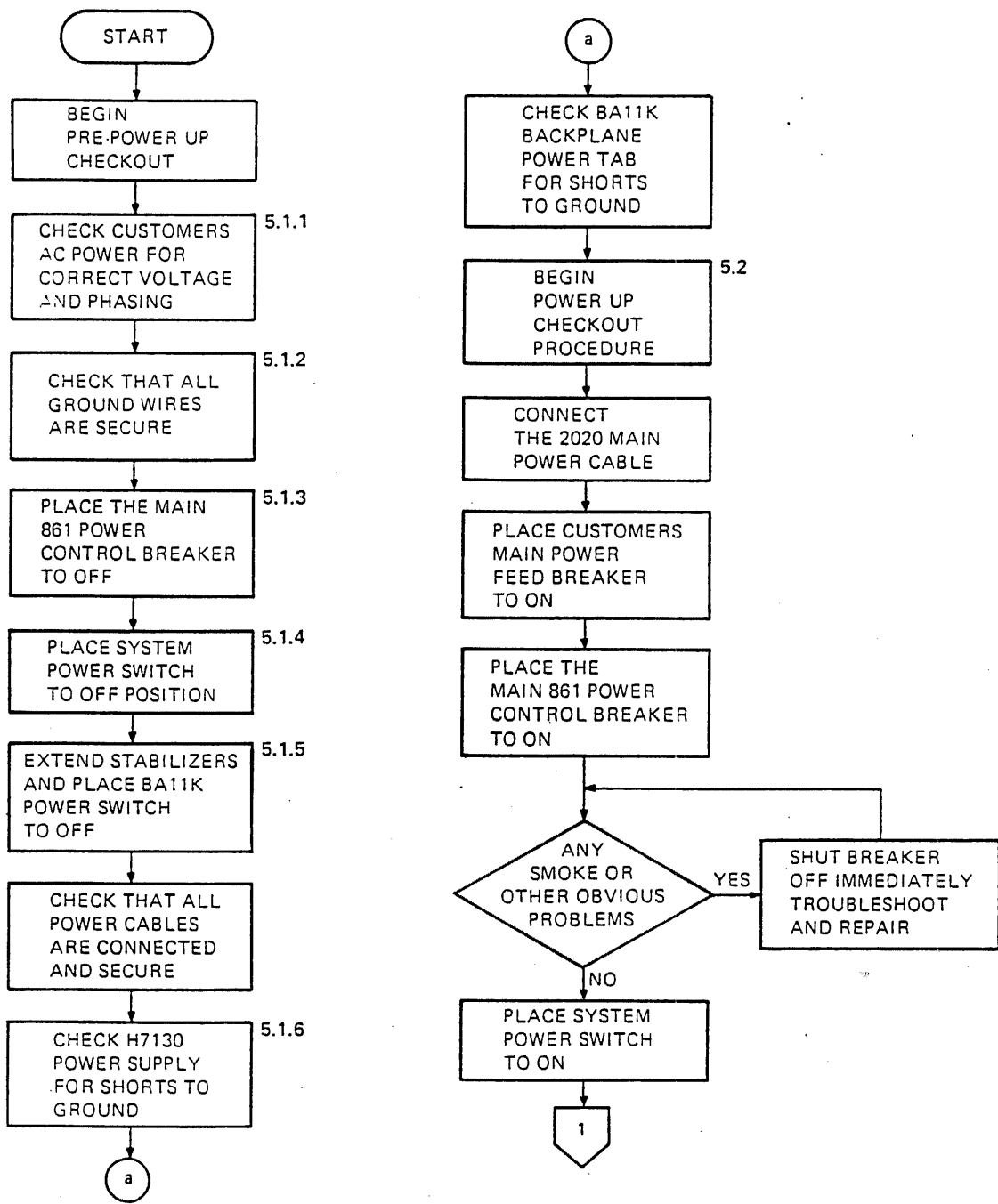

MR 1960

Figure 5-1 Power Checkout Flow (Sheet 1 of 3)

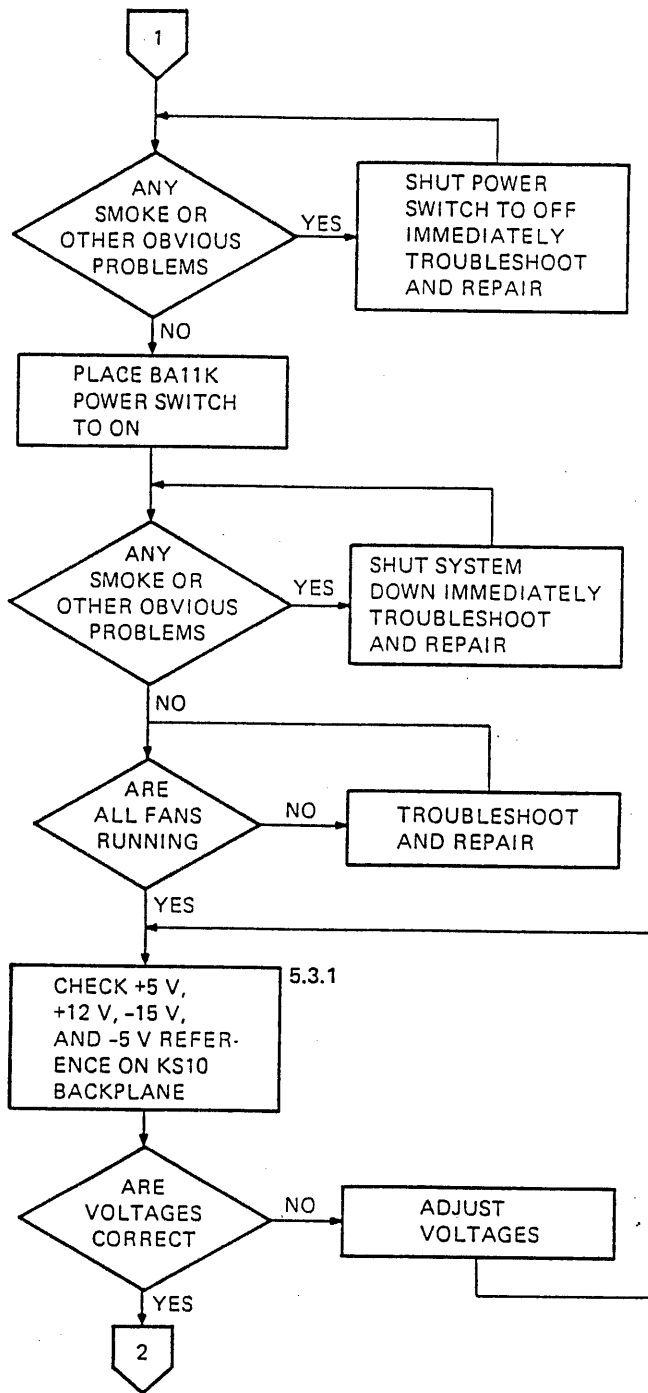

MR-1961

Figure 5-1 Power Checkout Flow (Sheet 2 of 3)

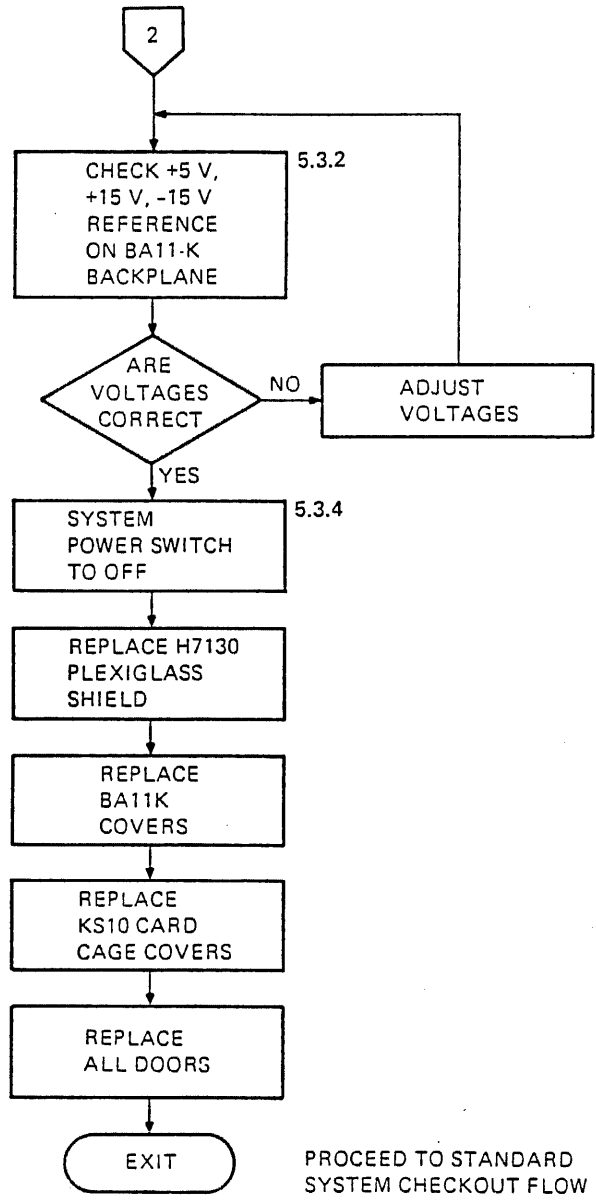

MR 1962

Figure 5-1 Power Checkout Flow (Sheet 3 of 3)

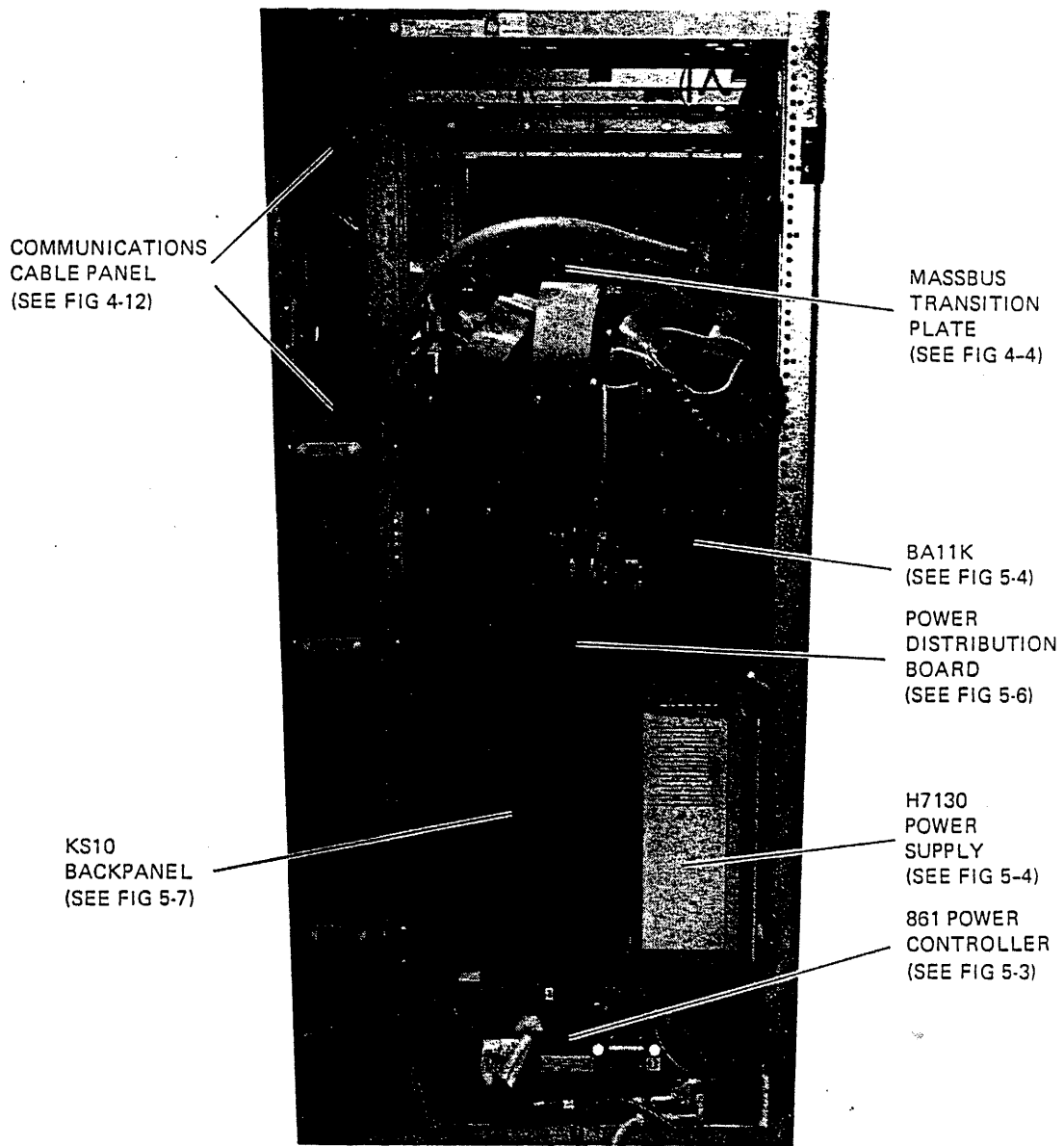
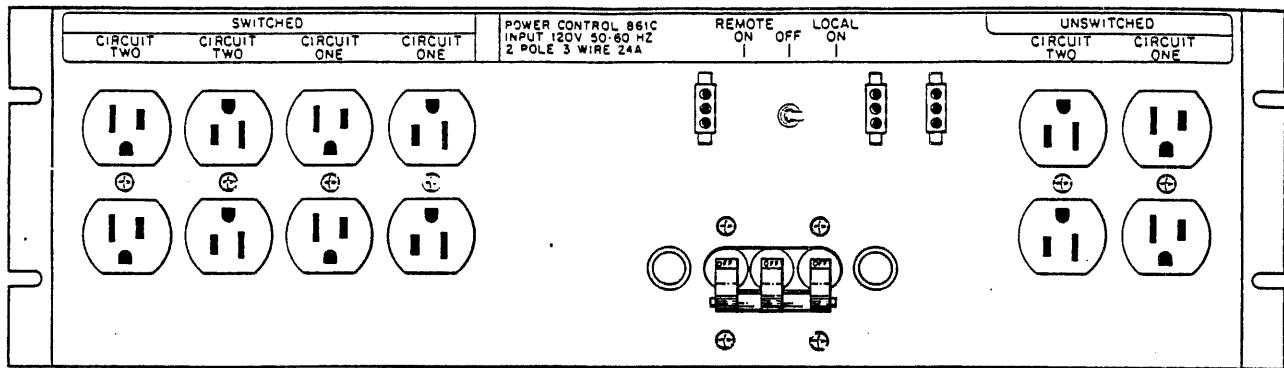

Figure 5-2 DECSYSTEM-2020 Cabinet (Rear)



MR-2071

Figure 5-3 861 Power Controller

5.1.3 Power Control

Refer to Figure 5-3.

1. Place the main 861 Power Control Breaker to the OFF position.
2. Ensure the J1 connection is secure.
3. Make certain three loads are connected to the 861 Power Control Switched Circuits.
 - a. Power Supply
 - b. KS10 PA Card Cage (fan)
 - c. BA11K Card Cage

5.1.4 Switch Panel

Ensure that the system power switch is in the OFF position.

5.1.5 Peripheral Drawer (BA11K)

Refer to Figure 5-4.

1. Fully extend and turn vertically the BA11K drawer.
2. Ensure the J1 connector is secure.
3. Place the BA11K circuit breaker to the OFF position.
4. Remove cover from BA11K backplane.

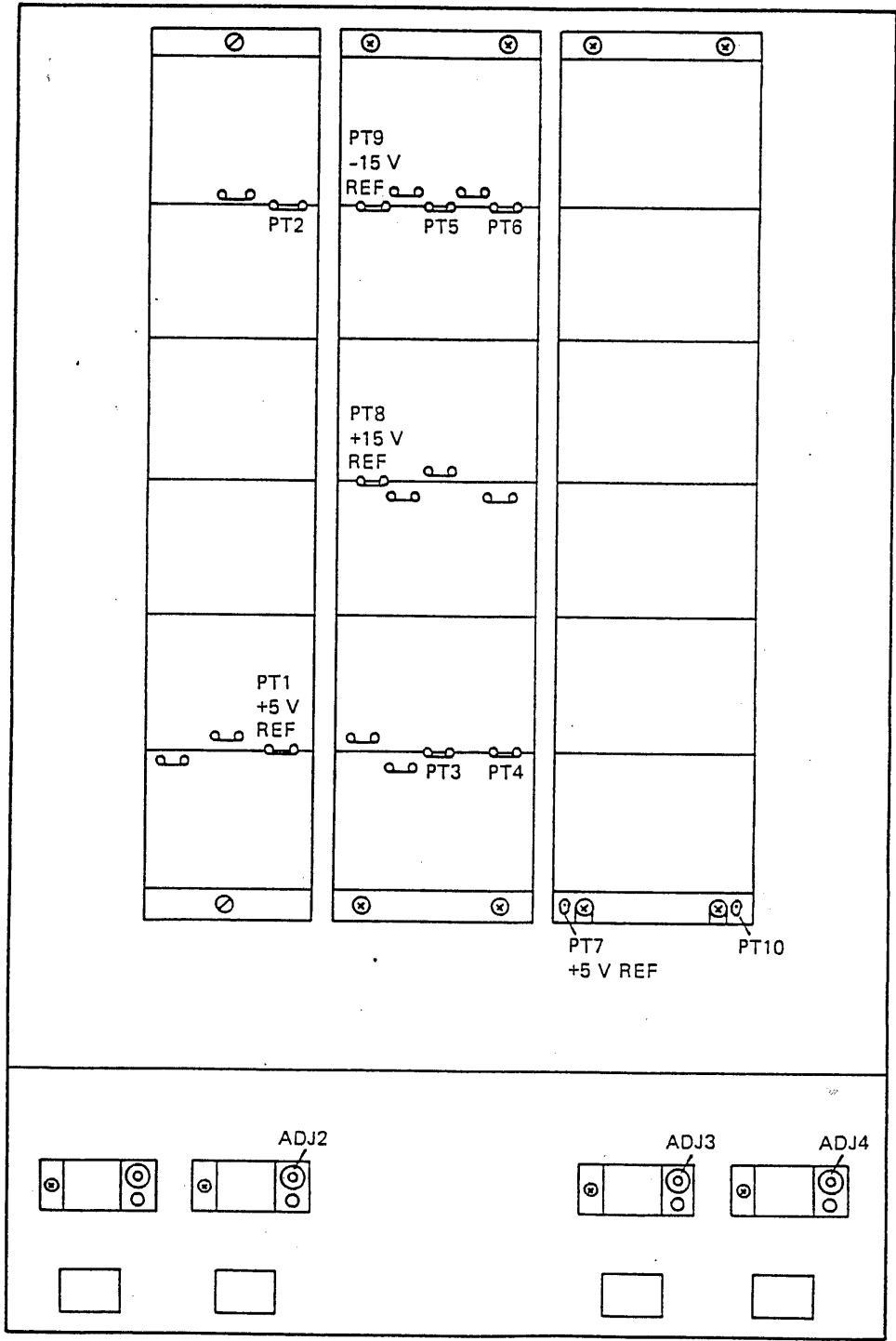

MR 1915

Figure 5-4 BA11K Backplane (KS10 Cabinet)

5.1.6 Logic Power Wiring

1. Visual Inspection – Give a thorough visual inspection of the KS10 and BA11K backplanes, power supply, wiring harness, and power distribution board. Check these areas for loose or broken wires, bent pins, or obvious shorts.
2. KS10 Short Checks – Unlock and swing out the H7130 power supply. Remove the plexiglass shield from the top of the power supply. Using the X1 (ohms) scale on a DVM check that no shorts exist between the listed power terminals and ground on the H7130 power supply. (See Figure 5-5 and Table 5-1.)

Table 5-1 KS10 Short Checks

Voltage	Terminal		Ground Terminal
+5	+V1	to	-V1
+5	+V2	to	-V2
+12	TB1-3 2 (+V3)	to	TB1-3 3 (-V3)
-5	TB1-3 8 (-V5)	to	TB1-3 7 (+V5)
-15	TB1-3 6 (-V4)	to	TB1-3 5 (+V4)

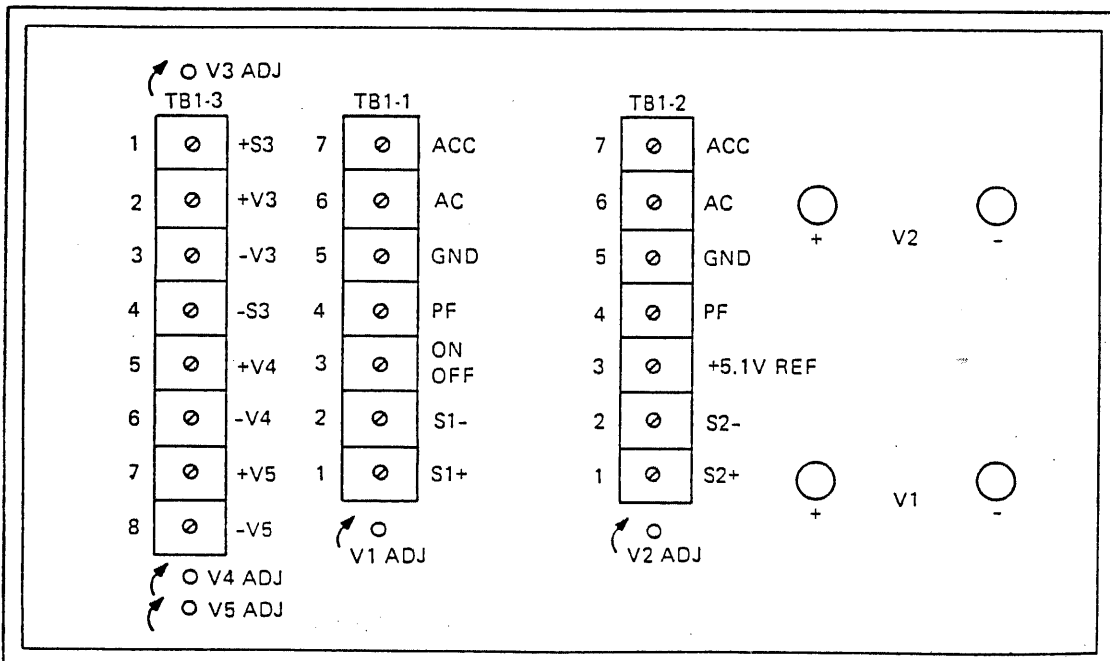

MR-1916

Figure 5-5 H7130 Power Supply

3. BA11-K Short Checks – Using the X1 (ohms) scale on a DVM check that no shorts exist between the listed voltage tabs and ground on the BA11K backplane. (See Figure 5-4 and Table 5-2.)

NOTE
PT defines Power Tab.

Table 5-2 BA11-K Short Checks

Voltage	Terminal	Chassis Ground
+5	PT 1	GND
+5	PT 2	GND
+5	PT 3	GND
+5	PT 4	GND
+5	PT 5	GND
+5	PT 6	GND
+5	PT 7	GND
+15	PT 8	GND
+15	PT 9	GND
-15	PT 10	GND

5.2 POWER UP CHECKOUT

1. Connect the 2020 main power cable (the cable coming from the 861C) to the main power feed.
2. Place the main power feed breaker to the ON position.
 - a. Ensure both power indicators on the 861C are ON. (See Figure 5-3.)
3. Place the 861C local/remote switch to the REMOTE position.
4. Place the 861 Power Control Breaker to the ON position.
5. Place the system power switch located on the front panel to the ON position.

NOTE
Perform a Control C.

- a. Ensure fan is blowing in the KS10 PA.
- b. Ensure LEDs on the power distribution board are on. (See Figure 5-6.)
6. Place the BA11K breaker to the ON position.
 - a. Ensure fan is blowing in BA11K.
 - b. Ensure lights are ON for each regulator. (See Figure 5-4.)

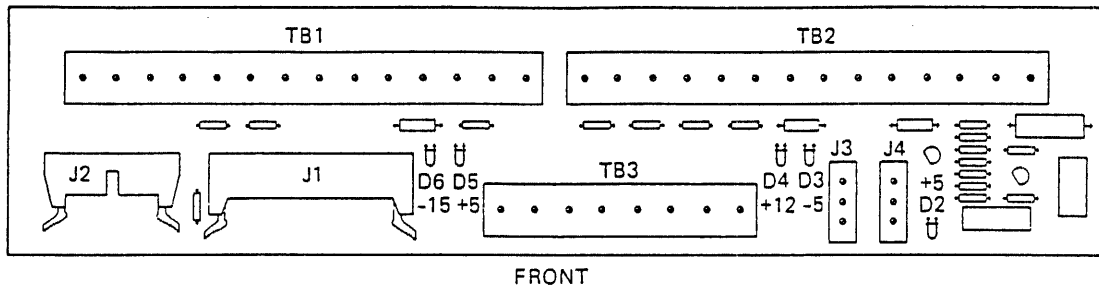

MR-1963

Figure 5-6 Power Distribution Board

5.3 VOLTAGE CHECKS AND ADJUSTMENTS

To check and adjust dc voltages in the KS10, first measure the reference for each of the voltages listed and adjust this reference to the exact value specified. The voltages not used as reference are then checked to ensure that they are within a specified range. All voltages are checked on the backplane of the KS10 PA and BA11K. All adjustments are made on their respective power supplies.

5.3.1 KS10 PA Backplane

(See Figure 5-7 and Table 5-3.) Set the indicated reference voltages and verify that the listed voltages are within the specified tolerances.

Table 5-3 KS10 Voltage Requirements

Voltage	(+) Pin or Power Tab	(-) Ground Reference	Adjustment Potentiometer	Voltage Limits
+5 (ref)	A09A2	Chassis	V1	Exact
+5	PT 1	Chassis		+4.75 to +5.25
+5	PT 7	Chassis		+4.75 to +5.25
+5 (ref)	PT 15	Chassis	V2	Exact
+5	PT 9	Chassis		+4.75 to +5.25
+5	PT 17 (RH11)	Chassis		+4.75 to +5.25
+5	PT 18 (RH11)	Chassis		+4.75 to +5.25
+5	PT 25 (RH11)	Chassis		+4.75 to +5.25
+5	PT 27 (RH11)	Chassis		+4.75 to +5.25
+12 (ref)	B08U2	Chassis	V3	Exact
-15	PT 14	Chassis	V4	Exact
-15	PT 29 (RH11)	Chassis		-15.75 to -14.25
-5 (ref)	B18B2	Chassis	V5	Exact

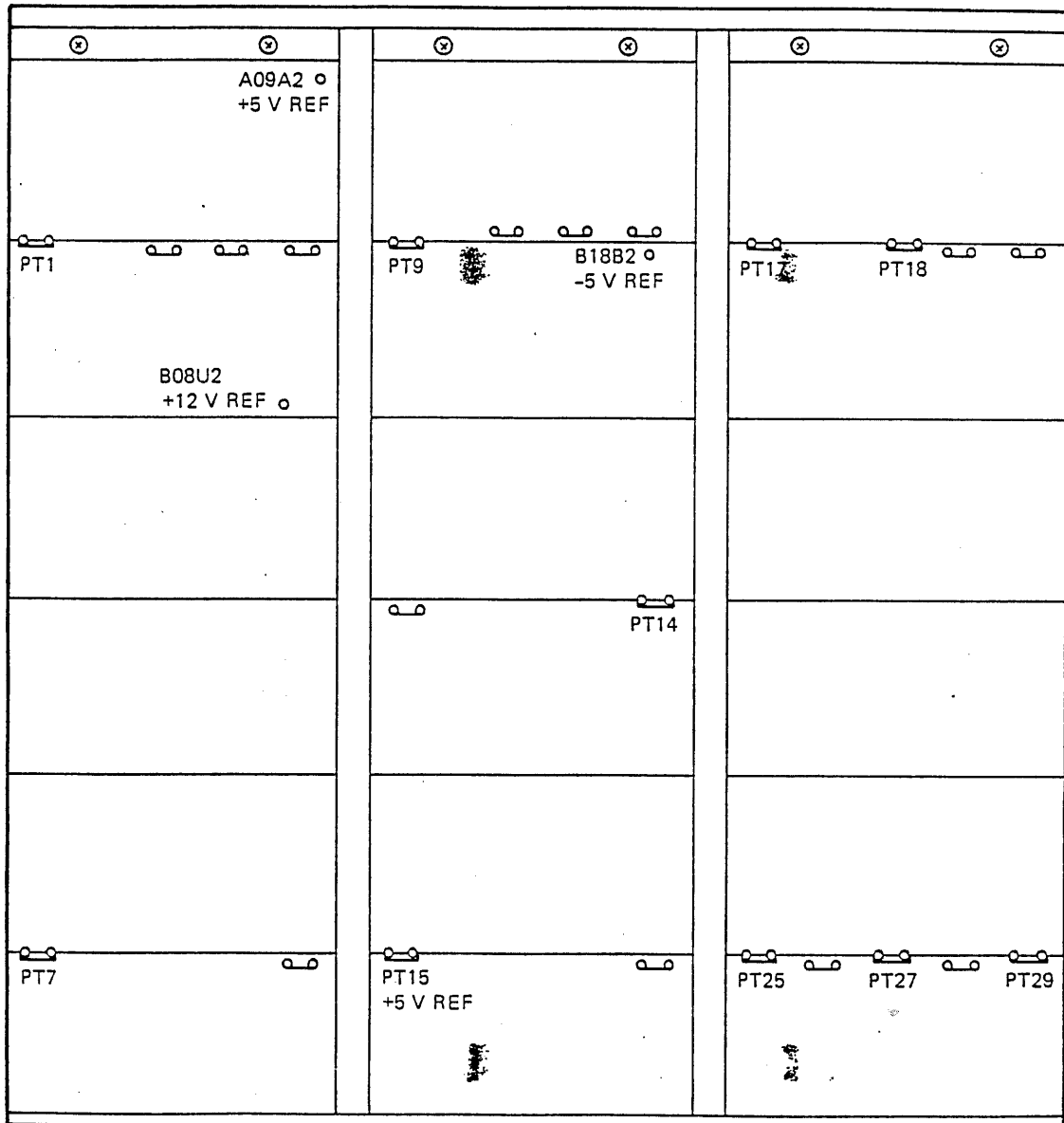

Figure 5-7 KS10 Backplane

MR 1917

Table 5-4 BA11-K Voltage Requirements

Voltage	(+) Power Tab	(-) Ground Reference	Adjustment Potentiometer	Voltage Limits
+5 (ref)	PT 1	Chassis	ADJ2	Exact
+5	PT 2	Chassis		+4.75 to +5.25
+5	PT 3	Chassis		+4.75 to +5.25
+5	PT 4	Chassis		+4.75 to +5.25
+5	PT 5	Chassis		+4.75 to +5.25
+5	PT 6	Chassis		+4.75 to +5.25
+5 (ref)	PT 7	Chassis	ADJ3	Exact
+15 (ref)	PT 8	Chassis	No pot	+14.25 to +15.75
-15 (ref)	PT 9	Chassis	ADJ4	Exact
-15	PT 10	Chassis		-15.75 to -14.25

5.3.2 BA11-K Backplane

(See Figure 5-4 and Table 5-4.) Set the indicated reference voltages and verify that the listed voltages are within the specified tolerances.

5.3.3 Peripherals

Power checkout procedures for the peripherals may be found in the individual technical manuals.

CR04 Manual, EP-CR04K/L-002
 RP06 Manual, ER-00012
 RM03 Manual, EK-RM03-UG-001
 TU45A Manual, EK-TU45A-MM-001

5.3.4 Conclusion

This completes the DECSYSTEM-2020 power checkout. If the DNHXX-A expansion cabinet is part of the system, proceed to Paragraph 5.4.

1. Place the system power switch (front panel) to the OFF position.
2. Replace covers over the KS10 card cage.
3. Replace the plexiglass shield over the top of the H7130 power supply. Turn and lock the supply in place.
4. Replace the covers on the BA11K card cage and retract the drawer.
5. Replace all doors.
6. Replace ground straps on the doors.

NOTE

Ensure the Installation/Acceptance Report has been filled out properly.

5.4 DNHXX-A PREPOWER CHECKOUT

5.4.1 BA11K Prepower Checkout

Refer to Figure 5-8.

1. Fully extend and turn the BA11K drawer vertically.
2. Ensure the J1 connector is secure.
3. Place the BA11K circuit breaker in the OFF position.
4. Remove cover from BA11K backplane.

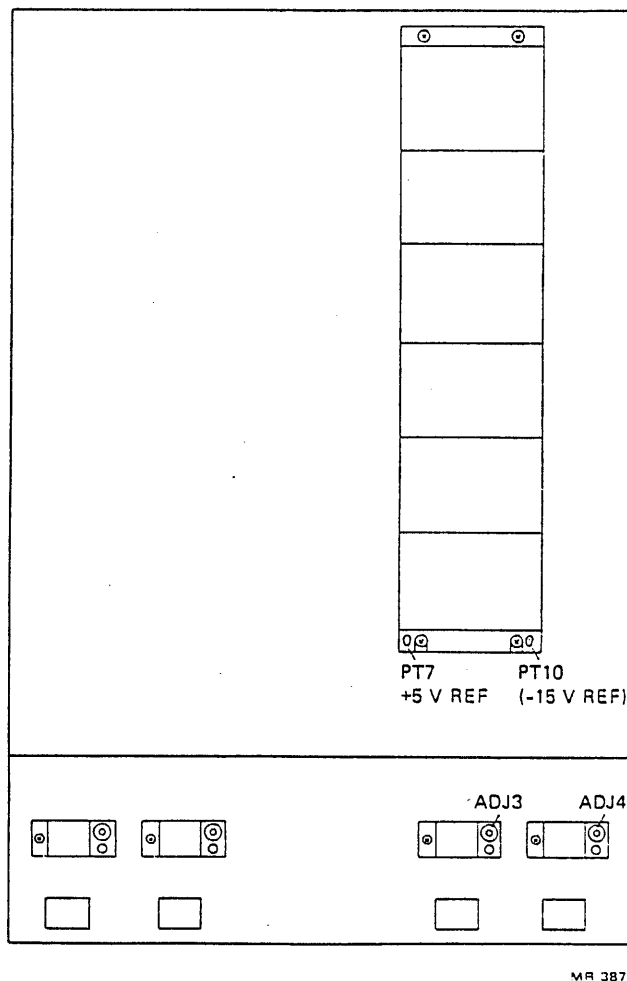

Figure 5-8 Power Tab and Adjustment Locations (DNHXX Cabinet)

5.4.2 BA11K Power Wiring

1. Visually inspect the BA11K backplane, power supply, and wiring harness. Check these areas for loose or broken wires, bent pins, or obvious shorts.
2. Using the X1 (ohms) scale on a DVM, check that no shorts exist between the listed voltage tabs and ground. Refer to Figure 5-8 and Table 5-5.

Table 5-5 DNHXX-A/BA11-K Short Checks

Voltage	Terminal	Chassis Ground
+5	PT 7	to GND
-15	PT 10	to GND

5.5 DNHXX-A POWER UP CHECKOUT

5.5.1 861C Power Controller

1. Connect the main power cable (the cable coming from the 861C) to the main power feed.
2. Place the main power feed breaker to the ON position.
 - a. Ensure both power indicators on the 861A are ON. (See Figure 5-3.)
3. Place the 861C local/remote switch to the REMOTE position.
4. Place the 861C power control breaker to the ON position.

5.5.2 BA11-K Power Up Checkout

1. Place the BA11K breaker to the ON position.
 - a. Ensure the fan is blowing in the BA11K.
 - b. Ensure the lights are ON for each regulator. (See Figure 5-8.)
2. Set the indicated reference voltages to their specified value. (See Figure 5-8 and Table 5-6.)

Table 5-6 DNHXX-A/BA11-K Voltage Requirements

Voltage	Power Tab	Ground Reference	Adjustment Pot	Voltage Limits
+5 (ref)	PT 7	Chassis	ADJ3	Exact
-15 (ref)	PT 10	Chassis	ADJ4	Exact

CHAPTER 6 STANDARD SYSTEM CHECKOUT PROCEDURES

6.1 INTRODUCTION

This chapter provides the installation engineer with a diagnostic sequence which, when successfully completed, enables the TOPS-20 monitor to be loaded and run. Any problems or errors that occur should be fixed and associated diagnostics rerun before continuing with the sequential checkout. The diagnostic run sequence is flowcharted in Figure 6-1.

If an option is listed but is not included in the system, skip the associated diagnostic process for that option and proceed to the next step. For NORAM the completion of system checkout constitutes running the Standard Test Procedures outlined in this chapter and beginning the 90-day warranty period.

NOTE

The examples found at the end of each phase list the CTY printout in capital letters. Input or response to questions is in boldface type.

6.2 TEST EQUIPMENT

The test equipment or media required for the standard diagnostic checkout procedure can be found in Paragraph 3.2.2 (additional tools required).

6.3 TEST SOFTWARE

6.3.1 System Loaders and Monitors

1.	BT256K.EXE	KS10 TOPS-20 Monitor Bootstrap
2.	KS10.RAM	KS10 Microcode
3.	KS10.RSQ	KS10 Ucode Sequence File
4.	KS10.ULD	KS10 Microcode
5.	SMAPT.SAV	Special Program
6.	SMBC2.SAV	KS10 Boot Check 2
7.	SMBOOT.EXE	KS10 TOPS-20 Monitor Bootstrap
8.	SMDDT.HLP	KS10 DDT Help File
9.	SMDDT.SAV	KS10 DDT
10.	SMFILE.EXE	Special program
11.	SMMAG.EXE	KS10 Magtape Monitor
12.	SMMON.EXE	KS10 Diagnostic Monitor
13.	SMMON.SAV	KS10 Diagnostic Monitor
14.	SUBSM.SAV	KS10 EXEC Subroutine Program
15.	SUBUSR.SAV	KS10 User Subroutine Program

6.3.2 KS10 CPU Functional Processor Diagnostics

1.	DSKAA.SAV	Basic Instruction Diagnostic No. 1
2.	DSKAB.SAV	Basic Instruction Diagnostic No. 2
3.	DSKAC.SAV	Basic Instruction Diagnostic No. 3
4.	DSKAD.SAV	Basic Instruction Diagnostic No. 4
5.	DSKAE.SAV	Basic Instruction Diagnostic No. 5
6.	DSKAF.SAV	Basic Instruction Diagnostic No. 6
7.	DSKAG.SAV	Basic Instruction Diagnostic No. 7

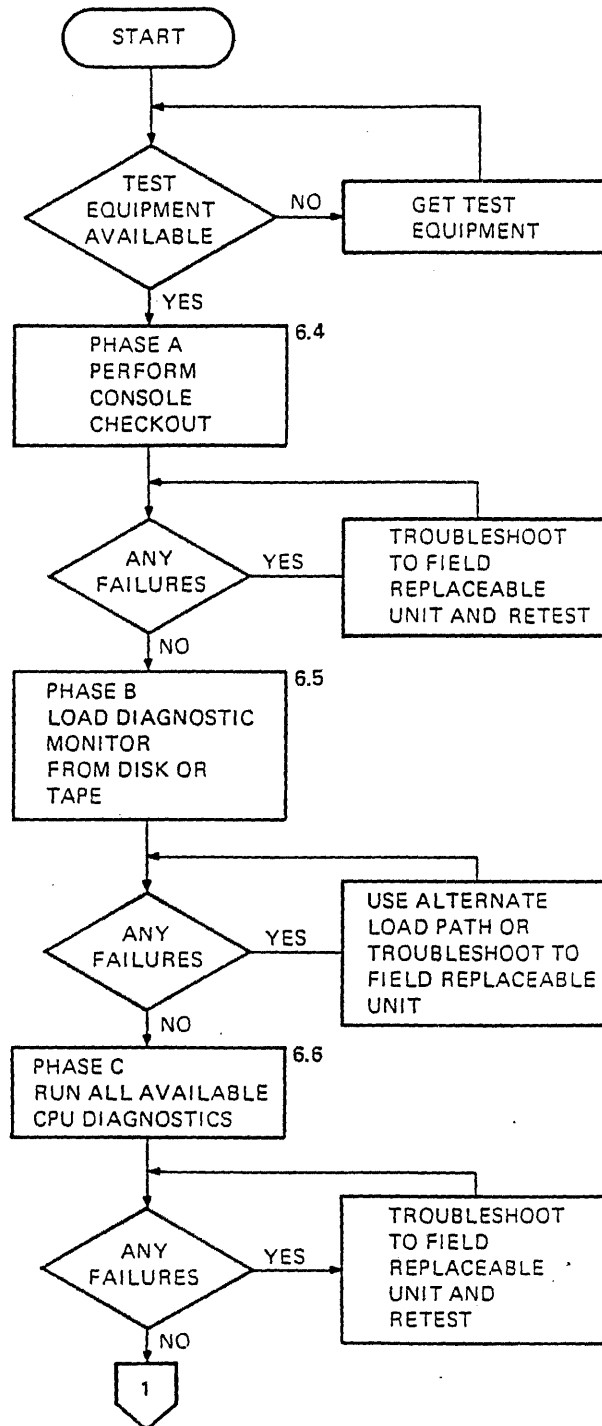

MR 1964

Figure 6-1 System Diagnostic Checkout (Sheet 1 of 4)

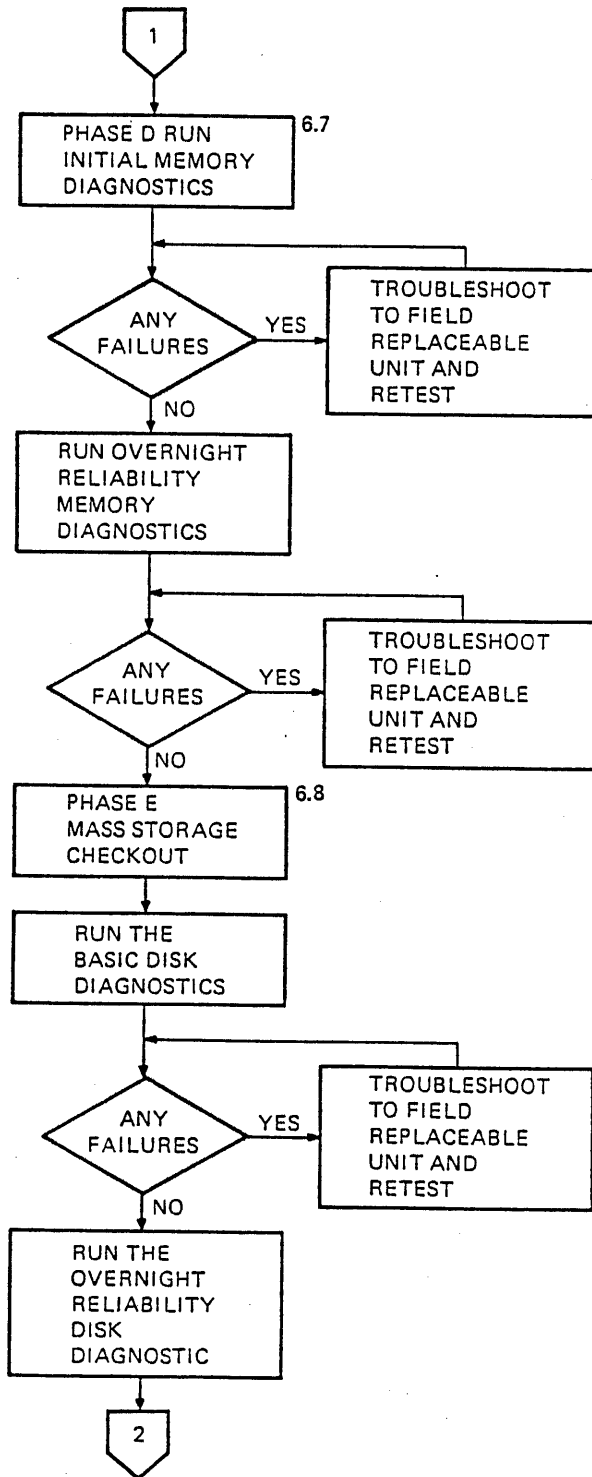

MR 1965

Figure 6-1 System Diagnostic Checkout (Sheet 2 of 4)

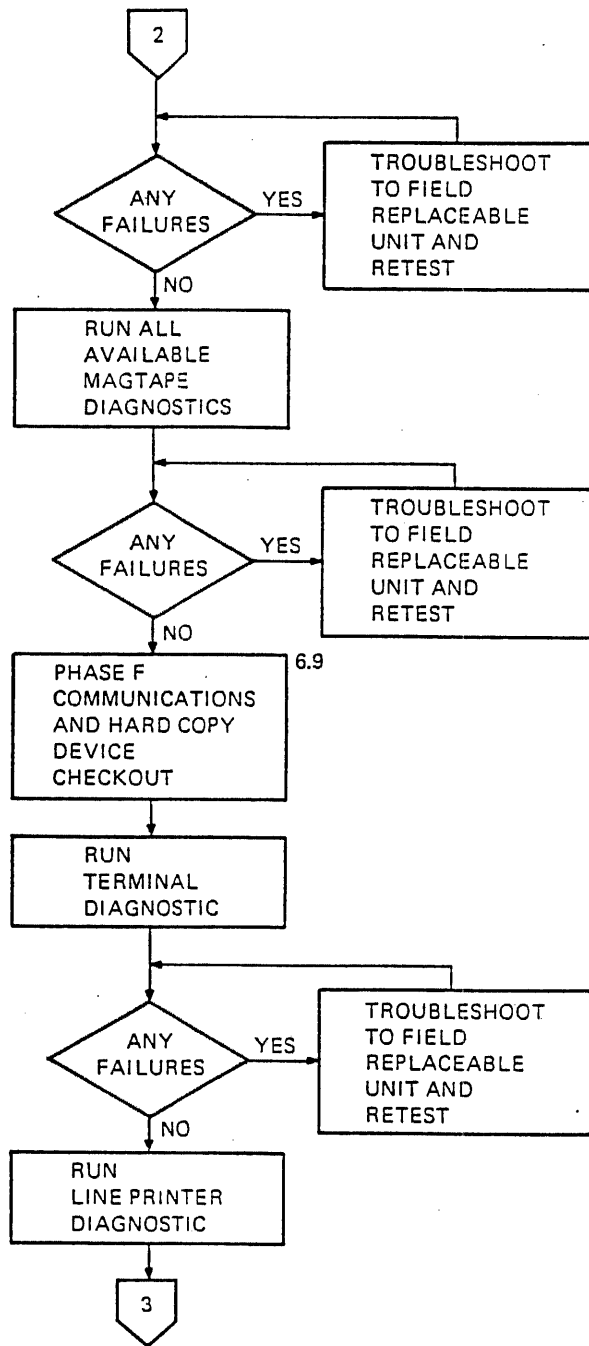

MR 1966

Figure 6-1 System Diagnostic Checkout (Sheet 3 of 4)

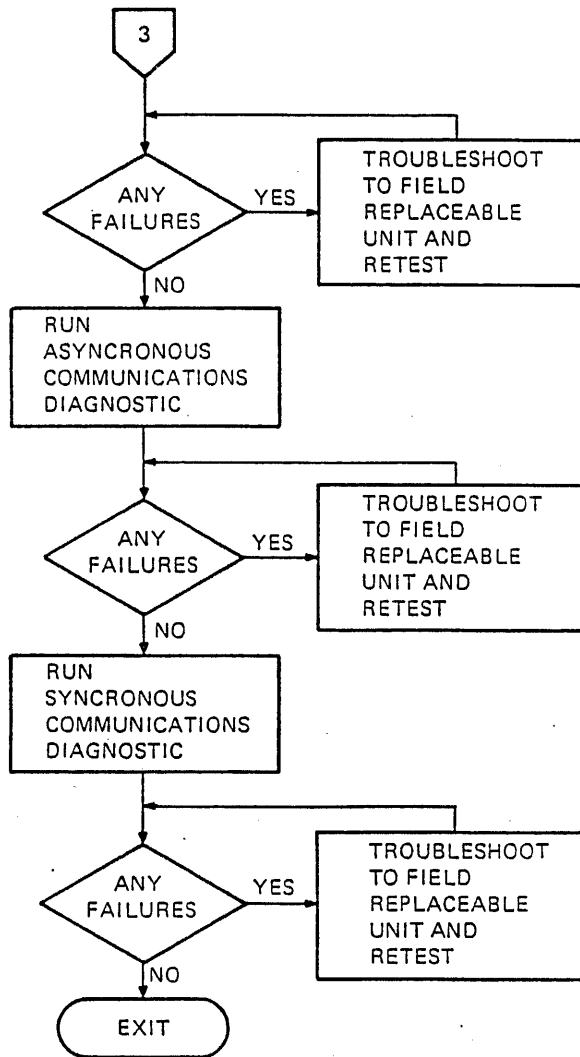

MR-1967

Figure 6-1 System Diagnostic Checkout (Sheet 4 of 4)

8.	DSKAH.SAV	Basic Instruction Diagnostic No. 8
9.	DSKAI.SAV	Basic Instruction Diagnostic No. 9
10.	DSKAJ.SAV	Basic Instruction Diagnostic No. 10
11.	DSKAK.SAV	Basic Instruction Diagnostic No. 11
12.	DSKAL.SAV	Basic Instruction Diagnostic No. 12
13.	DSKAM.SAV	Basic Instruction Diagnostic No. 13
14.	DSKBA.SAV	Basic Instruction Reliability No. 1
15.	DSKCA.SAV	Advanced Instruction Diagnostic No. 1
16.	DSKCB.SAV	Advanced Instruction Diagnostic No. 2
17.	DSKCC.SAV	Advanced Instruction Diagnostic No. 3
18.	DSKCD.SAV	Advanced Instruction Diagnostic No. 4
19.	DSKCE.SAV	Advanced Instruction Diagnostic No. 5
20.	DSKCF.SAV	Advanced Instruction Diagnostic No. 6
21.	DSKCG.SAV	Advanced Instruction Diagnostic No. 7
22.	DSKDA.SAV	Arithmetic Reliability

Paging and Cache Tests

1.	DSKEA.SAV	Paging Diagnostic
2.	DSKFB.SAV	Cache Diagnostic

Supplementary Test

1.	DSKFA.DAV	Instruction Timing Diagnostic
----	-----------	-------------------------------

6.3.3 Memory Diagnostics

1.	DSMMA.SAV	Memory Diagnostic
2.	DSMMB.SAV	Floating Ones/Zeros, BLT/Memory Exerciser
3.	DSMMC.SAV	Fast AC Diagnostic
4.	DSMMD.SAV	Memory Diagnostic

6.3.4 Mass Storage and Communications and Hard Copy Device Diagnostics

RM03/RP06 (Massbus) Disk Diagnostics

1.	DSRMA.SAV	RM03 Basic Diagnostic
2.	DSRMB.SAV	RM03/RP06 Reliability
3.	DSRPA.SAV	RP06 Basic Diagnostic

TM02/TM03 - TU45 Magtape Diagnostics

1.	DSTUA.SAV	RH11 TM03/TU45 Basic Diagnostic
2.	DSTUB.SAV	Magtape Reliability

CR04 Card Reader

1.	DSCDA.SAV	Card Reader Diagnostic
----	-----------	------------------------

Unibus Adapter

1. DSUBA.SAV Unibus Adapter Diagnostic

LP20 - LP05/LP14 Line Printer Diagnostic

1. DSLPA.SAV Line Printer Diagnostic

Asynchronous Communications (DZ11) Diagnostic

1. DSDZA.SAV DZ-11 Diagnostic

Synchronous Communications (KMC-DUP11) Diagnostics

1. DSDUA.SAV DUP11 Diagnostic
2. DSKMA.SAV KMC11 Diagnostic

LA36 Terminal Diagnostic

1. DSLTA.DAV Terminal Diagnostic

6.4 PHASE A - 8080 CONSOLE TESTING

The 8080 console checkout will ensure the console board is capable of executing bus dialogue to access the KS10 bus, memory, I/O registers and CRAM. Also, the console fault indicators and remote diagnosis path will be verified.

NOTES

1. This checkout is not intended to establish confidence in the KS10 bus, memory, I/O registers, or CRAM, only the consoles ability to access them.
2. All console commands will not be verified, only those necessary to perform bus dialogue.

6.4.1 LA36

1. Ensure power is ON.
2. Place ON LINE.
3. Set Baud Rate to 300.

6.4.2 Power On

Place the 2020 power switch to the ON position.

1. Power lamp will light.
2. CTY will respond with KS10 CSL.VO.X.X.

NOTE

There is now a 15 second period in which to enter a CONTROL C to inhibit AUTO-BOOT from taking place.

6.4.3 Master Reset

Perform a master reset (MR). This will reset the system.

6.4.4 Lamp Test

Perform a lamp test (LT). This will light all lamps, turn them off (except power), then restore original state.

6.4.5 KS10 Bus Operations

KS10 Bus operations will be verified by depositing 1s on the bus and then examining the bus to ensure their placement. This process will be repeated with 0s, alternating 1 and 0, and alternating 0 and 1. The commands used for this test are:

EB (examine bus)
DB (deposit bus).

Refer to Example 6.1.

6.4.6 Memory Operations

Memory operation will be verified by examining a specific memory location, depositing 1s into that location, and then examining the location to ensure their placement. This process will be repeated with 0s, alternating 1 and 0, and alternating 0 and 1. The commands used for this test are:

EM (examine memory)
DM (deposit memory).

Refer to Example 6.2.

6.4.7 I/O Operations

I/O operations will be verified by addressing the RH11's word count register, depositing 1s into that register, and then examining the register to verify the contents. This process will be repeated with 0s, alternating 1 and 0, and alternating 0 and 1. The commands used for this test are:

EI (examine I/O)
DI (deposit I/O).

Refer to Example 6.3.

6.4.8 Fault Detection

Testing of the console's ability to detect a fault will be accomplished by producing a parity error in CRAM. This will be indicated by the fault lamp lighting. Examine CRAM location 0; this could produce the fault. If the fault indicator did not come on, deposit a 3 into CRAM and examine 0. This will produce the error and light the front indicator. The commands used for this test are:

EC (examine CRAM)
DC (deposit CRAM).

Refer to Example 6.4.

6.4.9 CRAM Operation

CRAM operation will be verified by selecting a specific location in CRAM, depositing 1s into that location, and then examining the location to ensure their placement. This process will be repeated with 0s, alternating 1 and 0, and alternating 0 and 1. The commands used for this test are:

LC (load CRAM address)
DC (deposit CRAM)
EC (examine CRAM).

NOTE

Ignore any parity errors which may occur but ensure alternating 1 and 0 are in place.

Refer to Example 6.5.

6.4.10 Remote Link

The establishment of a remote link will verify the REMOTE input path to the console is functioning properly. The procedure to test this path is as follows.

1. Perform a master reset (MR).
2. Place the remote diagnosis switch located on the front panel to the ENABLE position.
 - a. Ensure the remote indicator lights (after a few seconds).
3. Enter KL 1 (REMOTE link).
4. Remove the CTY cable and the remote cable from the connectors in the back of the system. (See Figure 4-4.)
5. Place the CTY cable into the remote connector.
6. Enter 2 CONTROL BACKSLASHES.
 - a. The CTY will respond with KS10>.
 - b. This response indicates the path is good, baud rate is set properly, and the remote UART (universal asynchronous receiver transmitter) is functioning.
7. Replace and secure the CTY and remote cables to their original positions.
8. Ensure the modem and associated cables are connected properly.
9. Have DDC (Digital Diagnostic Center) or the branch office call into the MODEM and establish the link.

NOTE

A CTY and acoustic coupler are needed at the remote site.

10. Have the DDC or branch office set their CTY baud rate to 300 and enter 2 CONTROL BACKSLASHES.
 - a. The response on both terminals (remote and local) will be KS10>.
 - b. This response indicates the link has been established.
11. Enter KL0 and place the remote diagnosis switch to the DISABLE position.
12. This completes Phase A console checkout. Proceed to Phase B.

EXAMPLE 6.1
Accessing KS Bus

```
KS10>EB (CR)
BUS 0-35
000000,,000000
100/377 101/002 102/000 103/300 300/120 301/044 302/012 303/017
```

```
KS10>DB 777777777777 (CR)
```

```
KS10>EB (CR)
BUS 0-35
777777,,777777
100/377 101/002 102/000 103/317 300/120 301/144 302/012 303/017
```

```
KS10>DB 0 (CR)
```

```
KS10>EB (CR)
BUS 0-35
000000,,000000
100/377 101/002 102/000 103/300 300/120 301/144 302/012 303/017
```

```
KS10>DB 252525252525 (CR)
```

```
KS10>EB (CR)
BUS 0-35
252525,,252525
100/377 101/002 102/000 103/365 300/120 301/144 302/012 303/017
```

```
KS10>DB 525252525252 (CR)
```

```
KS10>EB (CR)
BUS 0-35
525252,,525252
100/377 101/002 102/000 103/372 300/120 301/144 302/012 303/017
```

```
KS10>
```

EXAMPLE 6.2
Accessing Memory

KS10>EM 20000 (CR)
000000,,020000/000000,,000000

KS10>DM 777777777777 (CR)

KS10>EM (CR)
000000,,020000/777777,,777777

KS10>DM 0 (CR)

KS10>EM (CR)
000000,,020000/000000,,000000

KS10>DM 252525252525 (CR)

KS10>EM (CR)
000000,,020000/252525,,252525

KS10>DM 525252525252 (CR)

KS10>EM (CR)
000000,,020000/525252,,525252

KS10>

EXAMPLE 6.3
I/O Operations

KS10>EI 1776702 (CR)
000001,,776702/000000,,000000

KS10>DI 177777 (CR)

KS10>EI (CR)
000001,,776702/000000,,177777

KS10>DI 0 (CR)

KS10>EI (CR)
000001,,776702/000000,,000000

KS10>DI 252525 (CR)

KS10>EI (CR)
000001,,776702/000000,,052525

KS10>DI 525252 (CR)

KS10>EI (CR)
000001,,776702/000000,,125252

KS10>

6.5 PHASE B - LOADING DIAGNOSTICS AND MICROCODE

The purpose of this phase is to load the microcode and diagnostic monitor, SMMON for disk or SMMAG for magtape. These programs will be used to load and run diagnostics to check out the CPU, memory, mass storage, communications, and hard copy devices.

6.5.1 Loading Diagnostics from Disk

1. Disk Unit 0 should have power cable and Massbus cables connected.
 - a. Turn AC breaker to ON.
 - b. Turn the breaker for MBA/RM03 or DCL/RP06 to ON.
2. Mount the RED PACK on disk unit 0.
3. Cycle up and write protect unit 0.
4. From the console enter the command MR (master reset) to reset the 2020.
5. From the console enter BT 1, Diagnostic Boot from Disk. This loads microcode and diagnostic monitor SMMON from the RED PACK mounted on drive 0.
6. The system should automatically start "SMMON" after loading. The response will be as follows.

SMMON[DSQDC] - DECSYSTEM 2020 DIAGNOSTIC MONITOR VER XX

SMMON.CMD -

Proceed to Phase C, CPU checkout (Paragraph 6.6) if this response is obtained.

7. If unable to load from the disk, attempt to load from the magtape as described in the following section. If both methods fail, troubleshoot the problem.

6.5.2 Loading Diagnostics from Magtape

1. Ensure MTA0 has both power cable and Massbus cable connected.
2. Place the MTA0 breaker to the ON position.
3. Place the MTA0 power switch to the ON position.
4. Mount diagnostic tape (RED TAPE 3) with write permit ring removed.
5. Set tape to load point and drive on line.
6. Ensure BA11-K has power on.
7. From the console enter MR to reset the 2020.

8. From the console enter the command MT, Diagnostic Boot from Magtape, to load microcode and diagnostic monitor SMMAG from diagnostic tape.
9. The system should automatically start SMMAG after loading. The response will be as follows.

KS10> USR MODE

SMMAG[DSQDE] - DECSYSTEM 2020 DIAGNOSTIC MAGTAPE MONITOR - VER
XX

SMMAG CMD -

10. Proceed to Paragraph 6.6 (Phase C - CPU checkout) if the above response is obtained.
11. If unable to load from diagnostic tape, attempt to load from the disk as described in the preceding paragraph (6.5.1). If both methods fail, troubleshoot the problem.

6.6 PHASE C - CPU CHECKOUT

This phase is designed to verify that all CPU functional processor diagnostics run error free. The quick verify CPU functional string and timing test should be run now and the longer reliability tests will be run overnight (reference Paragraph 6.7.1).

6.6.1 Quick Verify CPU Functional Diagnostic String (SMCPU)

An error free example illustrating the desired responses and the procedure to follow is presented in Example 6.6. This example presumes that the Phase B procedures in either Paragraph 6.5.1 or 6.5.2 have been successfully completed. If not, refer back to the appropriate paragraph and complete loading the microcode and diagnostic monitor.

1. With Phase B successfully completed, the last response on the CTY was SMMON CMD - (if loading diagnostics from disk) or SMMAG CMD - (if loading from tape).
2. Answer the questions using Example 6.6 as a guide. This will complete the Quick Verify CPU Functional Diagnostic String.

6.6.2 Instruction Timing Test

Example 6.7 (with cache) and Example 6.8 (without cache) illustrate the procedure to execute this test. Verify that the test runs error free. In cases where cache hits occur there will be approximately a 30 percent increase in speed.

1. Run DSKFA *with* cache using Example 6.7 as a guide.
2. Run DSKFA *without* cache using Example 6.8 as a guide. Ensure the LH switches are set to 20 (inhibit cache).
3. DSKDA is an arithmetic reliability test which should be run overnight. A procedure for creating a script for this test is contained in Paragraph 6.7.1.
4. This completes Phase C. Proceed to Paragraph 6.7, Phase D - Memory Checkout.

EXAMPLE 6.6
Quick Verify CPU Functional Diagnostic String

SMMON CMD - D (CR)

FILE.EXT - SMCPU (CR)

LH SWS - 0 (CR)

DSKAA.

DSKAB.

DSKAC.

DSKAD.

DSKAE.

DSKAF.

DSKAG.

DSKAH.

DSKAI.

DSKAJ.

DSKAK.

DSKAL.

DSKAM.

DSKCA.

DSKCB.

DSKCC.

DSKCD.

DSKCE.

DSKCF.

DSKBA.

VIRTUAL

MEMORY MAP =

FROM	TO	SIZE/K
00000000	00777777	256

TESTING 32K

DSKEA.

DSKEB.

SMMON PASS 1

EXAMPLE 6.7.
With Cache

SMMON CMD - DSKFA (CR)

DECSYSTEM 2020 INSTRUCTION TIMING TEST (DSKFA)

VERSION 0.1, SV=0.2, CPU#=4711, MCV=111, MCO=0, HO=0, KASW=003740 000000

TTY SWITCH CONTROL ? - 0,S OR Y <CR> - 0 (CR)

SWITCHES = 000000 000000

EXAMPLE 6.8
Without Cache

SMMON CMD - DSKFA (CR)

DECSYSTEM 2020 INSTRUCTION TIMING TEST (DSKFA)
VERSION 0.1, SV=0.2, CPU#=4711, MCV=111, MCO=0, HO=0, KASW=003740 000000

TTY SWITCH CONTROL ? - 0,S OR Y <CR> - Y (CR)

LH SWITCHES <# OR ?> - 20 (CR)

RH SWITCHES <# OR ?> - 0 (CR)

SWITCHES = 000020 000000

6.7 PHASE D - MEMORY CHECKOUT

The memory will initially be tested using memory diagnostic DSMMA, fast AC diagnostic DSMMC, BLT memory exerciser/floating 1s/0s diagnostic DSMMB. In order to create a script to run these tests, refer to the appropriate example.

NOTE

Soft (one bit) errors are allowed on these tests, although such errors should be logged for further maintenance use.

1. Load the Memory Diagnostics from disk or magtape. Refer to Paragraph 6.5.1 or 6.5.2
2. A script to execute all three tests is as follows.

SMMON CMD - T

DSMMA (TAB) 1 (TAB) 0 (TAB) 1 (CARRIAGE RETURN)

DSMMB (TAB) 1 (TAB) 0 (TAB) 1 (CARRIAGE RETURN)

DSMMC (TAB) 1 (TAB) 0 (TAB) 1 (CARRIAGE RETURN)

CONTROL Z

Refer to Example 6.9.

6.7.1 Overnight CPU/Memory Reliability Run

The script generated in Example 6.10 should be run overnight after the initial checkout is completed. This script is intended to verify that all remaining CPU and MEMORY diagnostics will run successfully.

This completes the memory checkout. Proceed to Paragraph 6.8, Phase E - Mass Storage Device Checkout.

EXAMPLE 6.9
Memory Diagnostic Chain

SMMON CMD - T (CR)

NAME	PASSES	RH SWS	ITERATIONS
DSMMA (TAB)	1 (TAB)	0 (TAB)	1 (CR)
DSMMB (TAB)	1 (TAB)	0 (TAB)	1 (CR)
DSMMC (TAB)	1 (TAB)	0 (TAB)	1 (CR)

CONTROL Z
 LH SWS - 0 (CR)
 DSMMA.

MEMORY MAP =
 FROM TO SIZE/K
 00000000 01777777 512

DECSYSTEM 2020 KS10 1024K MEMORY DIAGNOSTIC (DSMMA)
 VERSION 0.1, SV=0.2, CPU#=4711, MCV=111, MCO=0, HO=0, KASW=003740 000000

SINGLE BIT MEMORY ERROR

TN	PROG	PC	AS	PAT	ADDRESS	DATA	BIT #
6	031306	000006	SEQ	PADR	001417777		31
5	031372	000006	F35	MWC1	000675775	770163 652662	26
5	031372	000006	F34	MWC1	000675775	770163 652662	26
5	031372	000006	F33	MWC1	000675775	770163 652662	26
5	031372	000006	F32	MWC1	000675775	770163 652662	26
5	031372	000006	F31	MWC1	000675775	770163 652662	26
5	031372	000006	F30	MWC1	000675775	770163 652662	26
5	031372	000006	F29	MWC1	000675775	770163 652662	26
5	031372	000006	F28	MWC1	000675775	770163 652662	26

DSMMB.

VIRTUAL
 MEMORY MAP =
 FROM TO SIZE/K
 00000000 00777777 256

DSMMC.

SMMON PASS 1

CMD'S REQUIRED
 SMMON CMD -

EXAMPLE 6.10
Overnight Reliability

SMMON CMD - T (CR)

NAME	PASSES	RH SWS	ITERATIONS
DSMMA (TAB)	15 (TAB)	0 (TAB)	1 (CR)
DSKDA (TAB)	15 (TAB)	0 (TAB)	1 (CR)

CONTROL Z
LH SWS - 400 (CR)
DSMMA.

MEMORY MAP =
FROM TO SIZE/K
00000000 01777777 512

DECSYSTEM 2020 KS10 1024K MEMORY DIAGNOSTIC (DSMMA)
VERSION 0.1, SV=0.2, CPU#4711, MCV=111, MCO=0, HO=0, KASW=003740 000000

SINGLE BIT MEMORY ERROR

TN	PROG	PC	AS	PAT	ADDRESS	DATA	BIT #
6	031306	000006	SEQ	PADR	000675775		26
6	031306	000006	SEQ	PADR	000675775		26
6	031306	000006	SEQ	PADR	000675775		26
6	031306	000006	SEQ	PADR	000675775		26
6	031306	000006	SEQ	PADR	000675775		26
6	031306	000006	SEQ	PADR	000675775		26
6	031306	000006	SEQ	PADR	000675775		26
6	031306	000006	SEQ	PADR	000675775		26

DSKDA.

MEMORY MAP =
FROM TO SIZE/K
00000000 01777777 512

RUN TIME = 0:15:0

SMMON PASS 1

6.8 PHASE E – MASS STORAGE DEVICE CHECKOUT

The purpose of this chapter is to run both the basic and reliability tests on the RM03 and RP06 (disk drives) and the reliability test on the TU45 (tape drive). The reliability test for the disks will be run overnight. Paragraph 6.8.2 describes the procedure for the overnight disk reliability run. The decision of which mass storage device to test first depends on whether diagnostics are being run from disk or magtape. Whichever device is being used as a load source, *the other will be tested first*.

6.8.1 Disk Subsystem Checkout

The basic disk diagnostic DSRMA for RM03s or DSRPA for RP06s will be run to test the drives. It is first necessary to run DSRMB to format the scratch packs and check compatibility.

1. Formatting
 - a. Mount and cycle up a scratch pack(s) on the drive(s) to be tested.
 - b. Load DSRMB from magtape. Refer to Paragraph 6.5.2.
 - c. Within DSRMB run test PAKINT to format and verify all scratch packs. Refer to Example 6.11.
2. Compatibility
 - a. The same formatted pack should be rotated to each common drive in the system.
 - b. Verify that each drive of the same type (RM03 or RP06) can read the same formatted pack. Refer to Example 6.12.
3. Basic Disk Diagnostic
 - a. Follow the appropriate example:

Example 6.13 for DSRMA (RM03), or,
Example 6.14 for DSRPA (RP06).
 - b. All drives will successfully complete at least one error free pass.

NOTE

**A CONTROL T during either DSRMA or DSRPA
will type the current test PC.**

4. This completes the basic disk diagnostic. At this point the subsystem is ready for the overnight reliability test. Refer to Paragraph 6.8.2.

6.8.2 Disk Overnight Reliability

The disk reliability (DSRMB) will be run overnight on all RM03s and RP06s. The portion to run within DSRMB is entitled TOTAL. This will run all the tests. An example of starting TOTAL is given in Example 6.15.

1. Load DSRMB from the diagnostic tape as outlined in Paragraph 6.5.2.
2. Mount the formatted scratch packs on all RM03s and RP06s to be tested.

3. Example 6.15 tested only one drive. To test more than one drive, answer the questions appropriately as given in the example.

NOTE

Summary data is output every hour of run time. Check this data for hard errors that are *not* pack attributable. Each drive should complete at least one pass of "TOTAL".

4. If the tape drive has been tested proceed to Paragraph 6.9, Phase D – Communications and Hardcopy Device Checkout. If not, continue with Paragraph 6.8.3.

6.8.3 Magtape Subsystem Checkout

The reliability diagnostic (DSTUB) should be loaded from the RED PACK as described in Paragraph 6.5.1. An error free pass of each magtape diagnostic should be successfully completed for each drive on the system. Refer to Example 6.16 for an outline of the procedure.

NOTE

Recoverable bad spots on the magtape are allowed.

1. With the write ring inserted, mount a scratch tape and set it to the load point on each drive to be tested.
2. Using Example 6.16 as a guide, run the reliability (DSTUB) diagnostic.

NOTE

When a system has more than one magtape unit, the compatibility test must be run. Refer to Example 6.17.

3. This completes the magtape subsystem checkout. Proceed to Paragraph 6.9, Phase E – Communications and Hardcopy Device Checkout.

EXAMPLE 6.11

Formatting Scratch Pack(s)

SMMAG CMD - DSRMB (CR)

DSRMB - DECSYSTEM 2020 RH11 - RM03/RP06 - RELIABILITY DIAGNOSTIC
VERSION 0.1, SV=0.2, CPU#=4711, MCV=111, MCO=0, HO=0, KASW=003740 000000

TTY SWITCH CONTROL ? - 0,S OR Y <CR> - Y (CR)

LH SWITCHES <# OR ?> - 10 (CR)

RH SWITCHES <# OR ?> - 20000 (CR)

SWITCHES = 000010.020000

MEMORY MAP =

FROM	TO	SIZE/K
00000000	01777777	512

RH11 - 1 - MASSBUS CONFIGURATION
DRIVE - STATUS OF UNIT FOUND

0 - RM03, DRIVE SER. NO.=6343., (ONLINE), WRT ENABLED, DUAL PORT
*** 10 FORMATTED
NAME ID TYPE

1 - RM03, DRIVE SER. NO.=6345., , WRT ENABLED, DUAL PORT

2 - RM03, DRIVE SER. NO.=6346., , WRT ENABLED, DUAL PORT

3 - RP06, DRIVE SER. NO.=0442., , WRT ENABLED, DUAL PORT

WHAT DRIVE(S) TO BE TESTED (00 TO 77, ALL, H=HELP)? - E0 (CR)

DRIVE(S)? # - 0 (CR)

TYPE "H" FOR TEST NAME HELP MESSAGE
WHAT TEST ? - PAKINT <CR>

PAKINT - PACK INITIALIZE SCRIPT

FORMAT - MAP - AND GENERATE THE BAT BLOCKS
FOR THE SELECTED RP06/RM03 DISK DRIVES.
PROCEED WITH THE SCRIPT? Y OR N <CR> - Y (CR)

MAPOUT SOFT (RECOVERABLE) READ ERROR BLOCKS? Y OR N <CR> - N (CR)

PROGRAM RUN TIME = 0:0:18 FORMAT

THE PACK SPECIFICATION ALLOWS A TOTAL OF 20 ERRORS...
OF WHICH 5 MAY BE "HARD" ERRORS.
CYLINDER 000 SURFACE 00 CAN NOT HAVE ANY "HARD" ERRORS!

PROGRAM RUN TIME = 0:0:24 FORMATTING STARTED

PROGRAM RUN TIME = 0:2:57 OPERATION COMPLETED

EXAMPLE 6.11 (Cont)
Formatting Scratch Pack(s)

PROGRAM RUN TIME = 0:2:59 RONLY

-.~.*-*.~* DONE (RDY) INTERRUPT PGM SW = 000010 020000
PROGRAM RUN TIME = 0:4:15

DRAS: 000001

TEST NAME: "PAKINT" RUNNING "RONLY" AT PC ADDRESS 31217

DRIVE #0
DISK START ADDRESS IS: CYLINDER #673 SURFACE #02 SECTOR #00
(WHICH EQUALS LOGICAL BLOCK #66510.) BUFFER START ADDRESS = 121000
AND TRANSFER SIZE = 17000(8) OR 7680.(10)

PGM INTERRUPT PC WAS - 43304

RHCS1	1776700-0:	SC, TRE, DVA, RDY, FCNTN(30-34)=READ, GO-BIT=0
RHCS2	1776710:	IR, DRIVE=0
DRSR	1776712-0:	ATA, ERR, MOL, DPR, DRY, VV,
DRER1	1776714-0:	HCRC, HCE,
DRER2	1776742-0:	000000
DRDA	1776706-0:	SURFACE=2, SECTOR=2
DRDC	1776730-0:	DESIRED CYLINDER=673
DROF	1776732-0:	000000
DREC1	1776744-0:	ECC POSITION=2614.
DREC2	1776746-0:	000000

COMMAND ERROR RECOVERY @ ADDR 76021 IS
READ ISSUED TO DRIVE #00
PATTERN IS "ANY" STARTING @ DISK BLK #66510.
(CLY=673, SUR=2, SECT=0)
TRANSFER SIZE = 17000 AT.PGM PC #31226

HEADER ERROR DETECTED
DRIVE IS POINTING TO:
CYLINDER #673 SURFACE #02 SECTOR #01

HEADER WORD + TWO DATA WORDS ARE:
000160 000100 000000 000000 000000 000000
ATTEMPTING RECOVERY OF A 60. SECTOR TRANSFER BY INDIVIDUAL SECTORS

PROGRAM RUN TIME = 0:4:55
DRIVE RH1 - 0<3> CYL# 673 SURF# 02 SEC# 01 LOG BLK # 66511.
RECOVERED FROM A READ ON RETRY #15. (USED HEADER COMPARE INHIBIT)

=====

-.~.*-*.~* DONE (RDY) INTERRUPT PGM SW = 000010 020000
PROGRAM RUN TIME = 0:5:55

DRAS: 000001

EXAMPLE 6.11 (Cont)

Formatting Scratch Pack(s)

TEST NAME: "PAKINT" RUNNING "RONLY" AT PC ADDRESS 31217

DRIVE #0

DISK START ADDRESS IS: CYLINDER #1324 SURFACE #04 SECTOR #00
(WHICH EQUALS LOGICAL BLOCK #108720.) BUFFER START ADDRESS = 121000
AND TRANSFER SIZE = 17000(8) OR 7680.(10)

PGM INTERRUPT PC WAS - 43126

RHCS1 1776700-0: SC, TRE, DVA, RDY, FCNTN(30-34)=READ, GO-BIT=0
RHCS2 1776710: IR, DRIVE=0
DRSR 1776712-0: ATA, ERR, MOL, DPR, DRY, VV,
DRER1 1776714-0: DCK,
DRER2 1776742-0: 000000
DRDA 1776706-0: SURFACE=4,SECTOR-23
DRDC 1776734-0: DESIRED CYLINDER=1324
DROF 1776732-0: 000000
DREC1 1776744-0: ECC POSITION=3232.
DREC2 1776746-0: ECC PATTERN=2400

COMMAND ERROR RECOVERY @ ADDR 76031 IS
READ ISSUED TO DRIVE #00
PATTERN IS "ANY" STARTING @ DISK BLK #108720.
(CYL=1324, SUR=4, SECT=0)
TRANSFER SIZE = 17000 AT PGM PC #31226

ATTEMPTING RECOVERY OF A 60. SECTOR TRANSFER BY INDIVIDUAL SECTORS

ECC CORRECTION RECOVERY ##
ECC POSITION=3232. ECC PATTERN=2140
BUFFER ADDRESS 125531 125532
DATA BEFORE ECC 666666 625555 333370 666666
DATA AFTER ECC 666666 765555 333372 666666
CORRECTION ENTIRELY IN DATA FIELD

PROGRAM RUN TIME = 0:6:37
DRIVE RH1 - 0<3> CYL# 1324 SURF# 04 SECT# 22 LOG BLK# 108738.
RECOVERED FROM A READ ON RETRY #1.
ECC CORRECTION WAS USED...

=====

PROGRAM RUN TIME = 0:7:3 MAPOUT

BAT BLOCK CONTENTS

DRIVE RH1 - 0<3>, DRIVE SER. NO.=6343.,

LOG BLOCK	CYL (8)	SURF (8)	SECT (8)	CPU # (10)	UNIT # IN ERROR
66511.	0673	02	01	4711.	0

EXAMPLE 6.11 (Cont)
Formatting Scratch Pack(s)

SIZE OF BAD SPOT = 1. BLOCK
ENTRY VERS = 5, ERROR CODE = PARITY OR ECC ERROR
108738. 1324 04 22 4711. 0

SIZE OF BAD SPOT = 1. BLOCK
ENTRY VERS = 5, ERROR CODE = PARITY OR ECCC ERROR

BAD BLOCK/REGIONS BY DIAGNOSTIC = 2.
TOTAL # OF BAD BLOCKS DETECTED BY DIAGNOSTIC = 2.
BAD REGIONS BY MONITOR = 0. CHN # USED IN BAD BLK = 001
=====

DRIVE BAD BLOCKS CREATED
%% DRIVE #00 CONTAINS 2. BAD SPOT ENTRY(S)

WHAT TEST ? -

EXAMPLE 6.12
Verifying Drive Compatibility

MMAG CMD - DSRMB (CR)

DSRMB - DECSYSTEM 2020 RH11 - RM03/RP06 - RELIABILITY DIAGNOSTIC
VERSION 0.1, SV=0.2, CPU#=4711, MCV=111, MCO=0, HO=0, KASW=003740 000000

TTY SWITCH CONTROL ? - 0,S OR Y <CR> - Y (CR)

LH SWITCHES <# OR ?> - 10 (CR)
RH SWITCHES <# OR ?> - 20000 (CR)
SWITCHES = 000010 02000

MEMORY MAP =
FROM TO SIZE/K
00000000 01777777 512

RH11 - 1 - MASSBUS CONFIGURATION
DRIVE - STATUS OF UNIT FOUND

0 - RM03, DRIVE SER. NO.=6343., , WRT ENABLED, DUAL PORT
1 - RM03, DRIVE SER. NO.=6345., (ONLINE), WRT ENABLED, DUAL PORT
*** 10 FORMATTED
NAME ID TYPE

2 - RM03, DRIVE SER. NO.=6346., , WRT ENABLED, DUAL PORT
3 - RP06, DRIVE SER. NO.=0442., , WRT ENABLED, DUAL PORT

WHAT DRIVE(S) TO BE TESTED (00 TO 77, ALL, H=HELP)? - 1 (CR)

TYPE "H" FOR TEST NAME HELP MESSAGE
WHAT TEST ? - FORMAT (CR)

EXAMPLE 6.12 (Cont)
Verifying Drive Compatibility

FORMAT A PACK? Y OR N <CR> - N (CR)

VERIFY A FORMATTED PACK? Y OR N <CR> - Y (CR)

IT WILL BE REQUIRED TO RUN TEST "CONFIG" OR RESTART THE PGM
IF THE FOLLOWING QUESTION IS ANSWERED INCORRECTLY

36 BIT MODE (10 FORMAT)? Y OR N <CR> - Y (CR)

PROCESS ENTIRE PACK FOR ALL SELECTED DRIVES? Y OR N <CR> - Y (CR)

PROGRAM RUN TIME = 0:0:41 VERIFICATION STARTED

.-.*-.* DONE (RDY) INTERRUPT PGM SW = 000010 020000

PROGRAM RUN TIME = 0:2:46

DRAS: 000002

TEST NAME: "FORMAT" AT PC ADDRESS 33142

DRIVE #1

DISK START ADDRESS IS: CYLINDER #1324 SURFACE #04 SECTOR #00
(WHICH EQUALS LOGICAL BLOCK #108720.) BUFFER START ADDRESS = 121000
AND TRANSFER SIZE = 7436(8) OR 3870.(10)

PGM INTERRUPT PC WAS - 43122

RHCS1	1776700-1:	SC,TRE, DVA, RDY, FNCTN(30-34)=RHD+D, GO-BIT=0
RHCS2	1776710:	IR, DRIVE=1
DRSR	1776712-1:	ATA, ERR, MOL, DPR, DRY, VV,
DRER1	1776714-1:	DCK,
DRER2	1776742-1:	000000
DRDA	1776706-1:	SURFACE=4, SECTOR=23
DRDC	1776734-1:	DESIRED CYLINDER=1324
DROF	1776732-1:	000000
DREC1	1776744-1:	ECC POSITION=3232.
DREC2	1776746-1:	ECC PATTERN=2000

COMMAND ERROR RECOVERY @ ADDR 76017 IS
READ HEADERS & DATA ISSUED TO DRIVE #01
PATTERN IS "ANY" STARTING @ DISK BLK #108720.
(CYL=1324, SUR=4, SECT=0)
TRANSFER SIZE = 7436 AT PGM PC #33734

PROGRAM RUN TIME = 0:3:17
DRIVE RH1 - 1<3> CYL# 1324 SURF# 04 SECT# 00 LOG BLK# 108720.
RECOVERED FROM A READ HEADERS & DATA ON RETRY #1.

=====

PROGRAM RUN TIME = 0:3:40 OPERATION COMPLETED
WHAT TEST? -

EXAMPLE 6.13
Basic RM03 Diagnostic

SMMAG CMD - DSRMA (CR)

DSRMA DECSYSTEM 2020 RM03-RH11 BASIC DRIVE DIAGNOSTIC
VERSION 0.1, SV=0.2, CPU#=4711, MCV=111, MCO=0, HO=0, KASW=003740 000000

TTY SWITCH CONTROL ? - 0,S OR Y <CR> - 0 (CR)
SWITCHES = 000000 000000

MEMORY MAP =
FROM TO SIZE/K
00000000 01777777 512

CAUTION - - MOUNT SCRATCH PACK(S) BEFORE RUNNING.
THIS DIAG. WRITES THE PACK.

DUAL PORT TESTS DO NOT WRITE THE PACK

LIST PGM SWITCH OPTIONS ? Y OR N <CR> - N (CR)

ALL DRIVES BEING TESTED SHOULD BE LOCKED ON PROPER PORT
WITH DEVICE SELECT PLUG INSTALLED
UNLESS INSTRUCTED OTHERWISE ...

THE FOLLOWING RM03'S ARE DETECTED
DRIVES
0,1,2

SELECT DRIVES (0-7) OR "A" - 1 (CR)

THE FOLLOWING DEVICES HAVE BEEN TESTED
DRIVE-1 DRIVE TYPE=DUAL PORTED RM03 DRIVE SER. NO.=6345.
END PASS 1.

EXAMPLE 6.14
Basic RP06 Diagnostic

SMMAG CMD - DSRPA (CR)

DECSYSTEM 2020 RP06-RH11 BASIC DRIVE DIAGNOSTIC [DSRPA]
VERSION 0.1, SV=0.2, CPU#=4113, MCV=111, MCO=0, HO=0, KASW=003740 000000

TTY SWITCH CONTROL ? - 0,S OR Y <CR> - 0 (CR)
SWITCHES = 000000 000000

MEMORY MAP =
FROM TO SIZE/K
00000000 00777777 256

CAUTION - - MOUNT SCRATCH PACK(S) BEFORE RUNNING.
THIS DIAG. WRITES THE PACK. IF AN 11-FMT SCRATCH PACK IS USED,
IT WILL HAVE TO BE REFORMATED AFTER RUNNING THIS DIAG.

HEAD ALIGNMENT AND DUAL PORT TESTS DO NOT WRITE THE PACK

LIST PGM SWITCH OPTIONS ? Y OR N <CR> - N (CR)

ALL DRIVES BEING TESTED SHOULD BE LOCKED ON PROPER PORT
WITH DEVICE SELECT PLUG INSTALLED
UNLESS INSTRUCTED OTHERWISE ...

THE FOLLOWING RP06'S ARE DETECTED
3

SELECT DRIVES (0-7) OR "A" = 3 (CR)

THE FOLLOWING DEVICES HAVE BEEN TESTED
DRIVE-3 DRIVE TYPE=DUAL PORTED RP06, DRIVE SER. NO.=0442.,
END PASS 1.

EXAMPLE 6.15
RM03/RP06 Reliability

SMMAG CMD - DSRMB

DSRMB - DECSYSTEM 2020 RH11 - RM03/RP06 - RELIABILITY DIAGNOSTIC
VERSION 0.1, SV=0.2, CPU#=4711, MCV=111, MCO=0, HO=0, KASW=003740 000000

TTY SWITCH CONTROL ? - 0,S OR Y <CR> - Y (CR)

LH SWITCHES <# OR ?> - 10 (CR)
RH SWITCHES <# OR ?> - 20000 (CR)
SWITCHES = 000010 020000

MEMORY MAP =
FROM TO SIZE/K
00000000 01777777 512

RH11 - 1 - MASSBUS CONFIGURATION
DRIVE - STATUS OF UNIT FOUND

0 - RM03, DRIVE SER. NO.=6343., , WRT ENABLED, DUAL PORT
1 - RM03, DRIVE SER. NO.=6345., (ONLINE), WRT ENABLED, DUAL PORT

***** 10 FORMATTED**
NAME ID TYPE

2 - RM03, DRIVE SER. NO.=6346., , WRT ENABLED, DUAL PORT
3 - RP06, DRIVE SER. NO.=0442., , WRT ENABLED, DUAL PORT

WHAT DRIVE(S) TO BE TESTED (00 TO 77, ALL, H=HELP)? - 1 (CR)

TYPE "H" FOR TEST NAME HELP MESSAGE
WHAT TEST ? - TOTAL (CR)

EXAMPLE 6.16
DSTUB - Magtape Reliability

SMMON CMD - DSTUB (CR)

DECSYSTEM 2020 RH11-TM02/TM03-TU16/TU45 RELIABILITY DIAGNOSTIC (DSTUB)
VERSION 0.3, SV=0.2, CPU#=4145, MCV=111, MCO=0, HO=0 KASW=003740 000000

TTY SWITCH CONTROL ? - 0,S OR Y <CR> - 0 (CR)
SWITCHES = 000000 000000

MEMORY MAP =
FROM TO SIZE/K
00000000 01777777 512

SPECIFY TM (3=TM03,2=TM02,CR WILL TEST ALL ON-LINE DRIVES) (CR)

CONFIGURATION:
RH11# 3772440
TM02#0 TU45 #'S: 0
SN= 0627.

NOTE: ANY TAPES MOUNTED WRITE-ENABLED MAY BE WRITTEN ON.

WHAT TEST (H<CR> FOR HELP): R (CR)
TYPE NUMBER OF PROGRAM PASSES (DECIMAL) (CR=INFINITE): 1 (CR)
1600BPI RELIABILITY TEST
TM02/TU45 0/0 SN= 0627.

TM02/TU45 0/0 WRT ERR= 100000, DT= 040; REC#7. RECOVERED WITH 1. RETRY

TM02/TU45 0/0 WRT ERR= 100000, DT= 020; REC# 1103. RECOVERED WITH 1. RETRY

800BPI RELIABILITY TEST

CURRENT TEST= 3; CURRENT BUNCH= 1.; STATISTICS:

TM02/TU45 0/0 IN 1600BPI MODE

	RECORDS*	SERS*	HERS*	BS/DERS		NR OF WDS*		
WRITE:	1132		2.	0.	2.	2234210.		
RD FWD:	1130.		0.	0.	0.	2234210.		
RD REV:	1130.		0.	0.	0.	2234210.		
DEAD TRKS: (BIN WEIGHT, PHYS TRK #)								
0,2	1,8	2,1	3,9	4,3	5,5	6,6	7,7	P,4
0.	0.	0.	0.	2.	2.	0.	0.	0.

TM02/TU45 0/0 IN NRZI MODE

	RECORDS*	SERS*	HERS*	BS/DERS	NR OF WDS*	
WRITE:	595.		0.	0.	0.	1185579.
RD FWD:	593.		0.	0.	0.	1185579.
RD REV:	593.		0.	0.	0.	1185579.

END PASS 1.

EXAMPLE 6.17
Magtape Compatibility

SMMON CMD - DSTUB (CR)

DECSYSTEM 2020 RH11-TM02/TM03-TU16/TU45 RELIABILITY DIAGNOSTIC (DSTUB)
VERSION 0.3, SV=0.2, CPU#=4145, MCV=101, MCO=0, HO=0, KASW=00374 000000

TTY SWITCH CONTROL ? - 0,S OR Y <CR> - 0 (CR)
SWITCHES = 000000 000000

MEMORY MAP =
FROM TO SIZE/K
00000000 01777777 512

SPECIFY TM (3=TM03,TM02=TM02, CR WILL TEST ALL ON-LINE DRIVES) (CR)

CONFIGURATION:
RH11# 3772440
TM02#0 TU45 #S: 0, 1
SN= 0627. SN=0650.

NOTE: ANY TAPES MOUNTED WRITE-ENABLED MAY BE WRITTEN ON.

WHAT TEST (H<CR> FOR HELP): C (CR)
TM02/TU45 0/0 SN= 0627.
TM02/TU45 0/1 SN=0650

TYPE DATE AS MM-DD-YY: 5-11-79 (CR)
MOUNT COMPAT TAPE ON TM02/TU45 0/0, TYPE CR: (CR)
DO YOU WANT TO USE REDUCED-SIZE FORMAT (N=NORMAL FORMAT)?
Y OR N <CR> = N (CR)

CMD (CR,R=READ TAPE; W=BEGIN WRITING NEW TAPE; E=WRT EARLY EOT): W
(CR)

CMD(W=WRTBUNCH; CR,R=REWIND AND EXIT; E=ERASE): R (CR)

MOUNT COMPAT TAPE ON TM02/TU45 0/1, TYPE CR: (CR)
DO YOU WANT TO USE REDUCED SIZE FORMAT (N=NORMAL FORMAT)?
Y OR N <CR> - N (CR)

CMD (CR,R=READ TAPE; W=BEGIN WRITING NEW TAPE; E=WRT EARLY EOT): R (CR)

***TST # 11 ; TM02/TU45 0/1 ; ERR PC = 33614
***COMPATIBILITY TEST

ILLEGAL LOGOUT LAST WD XFERED ADDRESS. ADR = 00177740

OUR BUFFER STARTS AT LOCATION 00047000

CMD (W=WRTBUNCH; CR,R=REWING AND EXIT; E=ERASE): R (CR)

CURRENT TEST= 11; CURRENT BUNCH= 1.; STATISTICS:

EXAMPLE 6.17 (Cont)
Magtape Compatibility

TM02/TU45 0/0 IN 1600BPI MODE

	RECORDS*	SERS*	HERS*	BS/DERS	NR OF WDS*
WRITE: 201.		0.	0.	0.	207516.
RD REV: 1.		0.	0.	0.	0.
NO DEAD TRKS					

TM02/TU45 0/1 IN 1600BPI MODE

	RECORDS*	SERS*	HERS*	BS/DERS	NR OF WDS*
RD FWD: 201.		0.	0.	0.	207516.
RD REV: 199.		0.	0.	0.	207504.
NO DEAD TRKS					

TTY SWITCH CONTROL ? - O,S OR Y <CR> - ↑C
SMON CMD-

6.9 PHASE F - COMMUNICATIONS AND HARDCOPY DEVICE CHECKOUT

This phase verifies that all communications and hardcopy diagnostics run error free.

6.9.1 LA36 Terminal Diagnostic (DSLTA)

The following procedure ensures the proper operation of the teletype unit. An example of this test can be found in Example 6.18.

1. Ensure the LA36 cable is secure.
2. Ensure power is ON.
3. Ensure baud rate is set at 300.
4. Load DSLTA from disk or tape as described in Paragraphs 6.5.1 or 6.5.2, respectively.
5. Refer to Example 6.18 and ensure the diagnostic ran error free.
6. Proceed to Paragraph 6.9.2, line printer checkout.

6.9.2 LP20/LP14/LP05 Line Printer Checkout

The following procedure ensures the proper operation of the line printer. This diagnostic (DSLPA) will verify both controller and printer.

1. Ensure the LP20/LP14/LP05 cable is secure.
2. Ensure power breaker is on.
3. Ensure paper is loaded.
4. Ensure printer is on line.
5. Ensure all fault lights are out.
6. Load DSLPA from disk or tape as described in Paragraph 6.5.1 or 6.5.2, respectively.
7. Refer to Example 6.19 and ensure the diagnostic ran error free.

NOTE

Test 121 will fail if:

1. Module 8571 is REV D or lower
2. Module 8571 REV E is with module 8586 REV D or E.

If either condition 1 or 2 is present, set RH switch ELM 121 in order to pass test 121.

8. Proceed to Paragraph 6.9.3, CR04 Card Reader.

6.9.3 CR04 Card Reader

The following procedure ensures the proper operation of the card reader. Refer to the CR04 Card Reader diagnostic, Example 6.20 (DSCDA).

1. Ensure the CR04 cable is secure.
2. Ensure power breaker is on.
3. Ensure power switch is on.
4. Ensure all fault lights are out.
5. Load DSCDA from disk or tape as described in Paragraph 6.5.1 or 6.5.2, respectively.
6. Proceed to Paragraph, 6.9.4, Asynchronous Communication Checkout.

6.9.4 Asynchronous Communications Checkout

Proper operation of all DZ11 controllers and terminal lines are verified with this test. Example 6.21 outlines the procedure for running the (DSDZA) diagnostic and the desired results.

1. Load DSDZA from disk or tape as described in Paragraphs 6.5.1 or 6.5.2, respectively.
2. The diagnostic will be run to test the DZ11. (Refer to Example 6.21.)
3. Set all the terminals to 9600 baud in order to be compatible with Example 6.22.
4. Run the echo test. This will verify the total line out to the terminals. (Refer to Example 6.22.)
5. Once the echo test is started and questions answered, the following will be displayed on the terminal.

TYPE ANY CHARACTER FOR ECHO

TYPE CONTROL C TO EXIT TEST

6. Typing a control C on any terminal will cause the CTY to respond as follows.

DO YOU WISH TO ECHO TEST THE NEXT DZ11. Y OR N <CR> - Y
END PASS 1.

STARTING ECHO TEST

7. If an error free run is obtained, proceed to Paragraph 6.9.5, Synchronous Communications Checkout.

6.9.5 Synchronous Communications Checkout

This chapter will check out the KMC - DUP11 synchronous communications controllers. Refer to Example 6.23 for DSDUA and Example 6.24 for DSKMA. These examples outline the diagnostics and illustrate the desired results.

1. Disconnect modem and connect to BC05C-XX cable(s) coming from the DUP11(s).

NOTE

Excess BC05C-XX cable should be tied up in the rear of the CPU cabinet.

2. Load DSDUA and after completion load DSKMA from disk or tape as described in Paragraph 6.5.1 or 6.5.2, respectively.
3. Refer to Example 6.23 (DSDUA) or 6.24 (DSKMA) as a guide.

NOTE

Ensure the Installation/Acceptance Report has been filled out properly.

EXAMPLE 6.19 (Cont)
LP20 - LP05/LP14 Diagnostic

***A (CR)**

STARTING *BASIC REGISTER TESTING*
STARTING *REGISTER DISTURB TESTING*
STARTING *RAM ADDRESS AND DATA TESTING*
STARTING *SPECIAL PURPOSE REGISTER TESTING*
STARTING *(RAM) NPR TESTING*
STARTING *TEST MODE LOGIC TESTING*
STARTING *BASIC INTERRUPT TESTING*
STARTING *MISC LOGIC TESTING*
STARTING *LP20 PATTERN PRINTING TESTS*
TEST 111: EVERY COLUMN PRINTS THE SAME CHARACTER
TEST 112: MODIFIED RIPPLE PATTERN
TEST 113: VERTICAL ALIGNMENT PATTERN
TEST 114: HORIZONTAL ALIGNMENT PATTERN
TEST 115: CHECK HORIZONTAL TABS
TEST 116: CHECK THE OVERFLOW CORRECTION LOGIC
TEST 117: COMPLEMENT PATTERN (" " AND "-")
TEST 120: COMPLEMENT PATTERN ("*" AND "U")
TEST 121: COMPLEMENT PATTERN ("RUBOUT" AND "NULL")
TEST 122: CARRIAGE RETURN WITHOUT LINEFEED
TEST 123: EXERCISE COLUMN COUNTER
TEST 124: ILLEGAL CHARACTERS
TEST 125: EXERCISE COLUMN COUNTER
TEST 126: CHARACTER SPACING TEST
TEST 127: OVERPRINT TEST
TEST 130: DC0-4 TEST
TEST 131: DC3 TEST
TEST 132: DC1 TEST
TEST 133: DC2 TEST
TEST 134: DC4 TEST
TEST 135: DC0 TEST
TEST 136: VT TEST
TEST 137: RANDOM PATTERN TEST
TEST 140: CARRIAGE RETURN WITHOUT LINEFEED (SHUTTLE TEST #2)
TEST 141: EXERCISES COLUMN COUNTER (PATTERN #2)
TEST 142: SWIRL TEST PATTERN

EXAMPLE 6.20
CR04 Diagnostic

SMMAG CMD - DSCDA (CR)

DECSYSTEM 2020 CARD READER DIAGNOSTIC [DSCDA]
 VERSION 0.2, SV=0.2, CPU#=4097, MCV=111, MCO=0, HO=0, KASW=003740 000000

TTY SWITCH CONTROL ? - 0,S OR Y <CR> - Y (CR)

LH SWITCHES <# OR ?> - 0 (CR)
 RH SWITCHES <# OR ?> - ?(CR)
 CONTU - Y,N, <CR> OR , Z - (CR)

SWITCHES = 000000,000000

TYPE M<CR> FOR M200 MODEL CARD READER
 TYPE R<CR> FOR RS1200C MODEL CARD READER
 *M (CR)

TYPE ?<CR> TO HAVE THE CORRECT COMMAND FORMAT PRINTED.
 OTHERWISE, TYPE DESIRED TEST INFORMATION.

*? (CR)

CORRECT COMMAND FORMAT:

COMMAND FUNCTION

C<CR> DO ALL CONTROLLER ONLY TESTING
 D<CR> ENTER DDT
 <CR> PREVIOUSLY SPECIFIED TESTS ARE PERFORMED
 XXX<CR> ONLY TEST XXX WILL BE PERFORMED
 XXX-YYY<CR> TESTS XXX THROUGH YYY WILL BE PERFORMED
 XXX-<CR> ALLOWS RESPECIFICATION OF FIRST TEST IN GROUP OF TESTS
 -XXX<CR> ALLOWS RESPECIFICATION OF SECOND TEST IN GROUP OF TESTS
 A<CR> PERFORMS ALL TESTS ALLOWABLE IN CURRENT MODE (IE. .1-47 IN
 EXEC MODE AND 40 IN USER MODE)

.*

TEST#	FUNCTION	TEST#	FUNCTION
1	REGISTER ACCESS TEST	2	CDST REGISTER R/W TEST
3	CDST PWRCLR CLEAR TEST	4	CDST UBINIT CLEAR TEST
5	CDCC REGISTER R/W TEST	6	CDCC PWRCLR CLEAR TEST
7	CDCC UBINIT CLEAR TEST	10	CDBA REGISTER R/W TEST
11	CDBA PWRCLR CLEAR TEST	12	CDBA UBINIT CLEAR TEST
13	CDST 0'S DISTURB TEST	14	CDCC 0'S DISTURB TEST
15	CDBA 0'S DISTURB TEST	16	LOW LOAD ON CDCC TEST
17	HIGH LOAD ON CDCC TEST	20	LOW LOAD ON CDBA TEST
21	HIGH LOAD ON CDBA TEST	22	ONLINE AND TRANSOL TEST
23	CDDDB READ TEST	24	READY BIT CLEAR TEST
25	HOPPER CHECK AFTER READ TEST		
26	READ BIT CLEAR TEST	27	BASIC INTERRUPT TEST
30	CDCC OVERFLOW TEST	31	NON-EXISTENT MEMORY TEST
32	NXM ERROR CLEAR TEST	33	NXM NPR INHIBIT TEST

EXAMPLE 6.20 (Cont)
CR04 Diagnostic

34	CDBA AND CDCC REGISTER EXERCISOR TEST		
35	ALPHANUMERIC PACK DATA RELIABILITY TEST		
36	BINARY PACK DATA RELIABILITY TEST		
37	BINARY NON-PACK DATA RELIABILITY TEST		
40	ALPHANUMERIC NON-PACK DATA RELIABILITY TEST (USER OR EXEC MODE)		
41	INPUT HOPPER EMPTY TEST	42	OUTPUT STACKER FULL TEST
43	PICK CHECK ERROR TEST	44	STACK CHECK ERROR TEST
45	READ CHECK ERROR TEST	46	EOF SET TEST (RS1200C ONLY)
47	OFFLINE READ ERROR TEST		

*A (CR)
STARTING *BASIC REGISTER TESTING*
STARTING *REGISTER DISTURB TESTING*
STARTING *REGISTER BYTE LOAD TESTING*

TEST 22: ON LINE AND TRANSITION TO ON LINE TEST

LOAD BOTH TEST DECKS INTO THE HOPPER (ANY ORDER).
PRESS STOP THEN RESET. TYPE <CR> (CR)

TEST 23: CDDDB READ TEST
TEST 24: READY BIT CLEAR TEST
TEST 25: HOPPER CHECK AFTER READ TEST
TEST 26: READ BIT CLEAR TEST
TEST 27: BASIC INTERRUPT TESTING
TEST 30: COLUMN COUNT OVERFLOW TEST
TEST 31: NON-EXISTENT MEMORY ERROR SET TEST
TEST 32: NON-EXISTENT MEMORY CLEAR TEST
TEST 33: NON-EXISTENT MEMORY NPR INHIBIT TEST
TEST 34: CDBA AND CDCC REGISTER EXERCISOR TEST

THE INPUT HOPPER SHOULD BE LOADED AT LEAST 80 CARDS. IF IT IS NOT LOAD THE HOPPER, PRESS RESET, AND TYPE <CR>. OTHERWISE JUST TYPE <CR> (CR).

TEST 35: ALPHA PACK MODE TEST

LOAD THE CARD DECK LABELED ALPHANUMERIC. PUT A BLANK CARD AT THE END. PRESS RESET AND TYPE <CR> (CR)

TEST 36: BINARY PACK MODE TEST

LOAD THE CARD DECK LABELED BINARY. PUT A BLANK CARD AT THE END. PRESS RESET AND TYPE <CR> (CR)

TEST 37: BINARY NON-PACK MODE TEST

LOAD THE CARD DECK LABELED BINARY. PUT A BLANK CARD AT THE END. PRESS RESET AND TYPE <CR> (CR).

EXAMPLE 6.20 (Cont)
CR04 Diagnostic

TEST 40: ALPHA NON-PACK MODE TEST

LOAD THE CARD DECK LABELED ALPHANUMERIC. PUT A BLANK CARD AT THE END. PRESS RESET AND TYPE <CR> (CR)

STARTING *MECHANICAL ERROR TESTING*
!!RUN ONLY IF CARDS OTHER THAN THE TEST DECKS ARE AVAILABLE!!

TEST 41: INPUT HOPPER EMPTY TEST

REMOVE ALL CARDS FROM THE INPUT HOPPER. THEN TYPE <CR>. (CR)

TEST 42: OUTPUT STACKER FULL TEST

LOAD THE INPUT HOPPER AND PRESS RESET
CDR IS NOW ONLINE

LOAD THE INPUT HOPPER AND PULL THE STACKER ARM ALL THE WAY DOWN TO CAUSE AN OUTPUT STACKER FULL ERROR. THEN TYPE <CR> (CR)

TEST 43: PICK CHECK ERROR TEST

PLACE A FOLDED CARD AS THE FIRST CARD IN THE INPUT HOPPER. PRESS RESET AND THEN TYPE <CR> (CR)

TEST 44: STACK CHECK ERROR TEST

THE HOPPER MUST BE LOADED WITH AT LEAST 80 CARDS. PRESS RESET AND TYPE <CR> (CR)

*** MODEL RS1200C ***

PULL THE STACKER ARM PART WAY DOWN WHILE THE CARDS ARE BEING READ.

*** MODEL M200 ***

DEFLECT THE CARDS WITH YOUR HAND WHILE THEY ARE BEING READ.

TEST 45: READ CHECK ERROR TEST

INSERT A MUTILATED CARD AS THE FIRST CARD IN THE INPUT HOPPER. THEN TYPE RESET AND <CR> (CR)

LOAD THE INPUT HOPPER AND PRESS RESET
CDR IS NOW ONLINE

TEST 46 SKIPPED IF M200 READER
TEST 47: OFFLINE READ ERROR TEST

PRESS STOP AND TYPE <CR> (CR)

*

EXAMPLE 6.21
DSDZA - DZ11 Diagnostic (Internal)

SMMAG CMD - DSDZA (CR)
DECSYSTEM 2020 DZ11 ASYNC. LINE MUX DIAGNOSTICS (DSDZA)
VERSION 0.1, SV=0.2, CPU#= 4711, MCV=111, MCO=0, HO=0, KASW=003740 000000

TTY SWITCH CONTROL ? - 0,S OR Y <CR> - 0 (CR)
SWITCHES = 000000 000000

MEMORY MAP =
FROM TO SIZE/K
00000000 01777777 512

SYSTEM MAP

DEVICE ADDRESS = 3760010
VECTOR = 340
BR LEVEL = 5
ACTIVE LINES BY BIT = 377
LINE PARAMETERS = 017470
END PASS 1.

EXAMPLE 6.22

Echo Test

SMMON CMD - DSDZA (CR)

DECSYSTEM 2020 DZ11 ASYNC. LINE MUX DIAGNOSTICS (DSDZA)
VERSION 0.1, SV=0.2, SV=0.1, CPU#=4097, MCV=111, MCO=0, HO=0
KASW=003740 000000

TTY SWITCH CONTROL ? - 0,S OR Y <CR> - Y (CR)

LH SWITCHES <# OR ?> - 0 (CR)

RH SWITCHES <# OR ?> - 2 (CR)

SWITCHES = 000000 000002

MEMORY MAP =

FROM	TO	SIZE/K
00000000	01777777	512

SYSTEM MAP

DEVICE ADDRESS = 3760010

VECTOR = 340

BR LEVEL = 5

ACTIVE LINES BY BIT = 377

LINE PARAMETERS = 017070

TEST NO. (1 - 33 OCTAL) = 33 (CR)

STARTING ECHO TEST IF BAUD WAS NOT

SPECIFIED THE DEFAULT WILL BE 9600

DO YOU WANT TO SEQUENCE THROUGH

THE LINES ONE AT A TIME. Y OR N <CR> - N (CR)

DO YOU WISH TO ECHO TEST THE NEXT DZ11. Y OR N <CR> - Y (CR)

END PASS 1.

EXAMPLE 6.23
DSDUA - KMC11 Diagnostic

SMMAG CMD - DSDUA (CR)

DSDUA DECSYSTEM 2020 DUP-11 DIAGNOSTICS
VERSION 0.1, SV=0.2, CPU#=4711, MCV=111, MCO=0, HO=0, KASW=003740 000000

TTY SWITCH CONTROL ? - 0,S OR Y <CR> - 0 (CR)
SWITCHES = 000000 000000

'COMMAND MODE' IS INDICATED WHEN THE PROGRAM TYPES
AN "*" AT THE LEFT SIDE OF THE TERMINAL. TO RE-START
THE ONCE ONLY DIALOG FROM 'COMMAND MODE' TYPE "&".
IS THE DUP-11 UNIT #1?
Y OR N <CR> - Y (CR)

DO YOU WANT A MAP OF THE DUP-11 STATUS ?
Y OR N <CR> - Y (CR)

IS THE H325 TURN AROUND CONNECTER IN PLACE ?
Y OR N <CR> - Y (CR)
* INITIAL DUP STATUS MAP *

UNIBUS ADAPTER IS #03
DUP11 IS #01

RXCSR :000000 000000
RXDBUF:000000 000000
TXCSR :000000 000200
TXDBUF:000000 000000
UASTAT:000000 000001

TYPE ? TO GET FORMAT ON (TERMINAL), OR % TO GET SUMMARY OF CONTROLLER
TESTS, (SEE TEXT FILE FOR CONTROL OF SUMMARY OUTPUT DEVICE SELECTION.)

*A (CR)

STARTING *BASIC REGISTER TESTING*

*ACCESSING REGISTER:000003760300

*ACCESSING REGISTER:000003760302

*ACCESSING REGISTER:000003760304

*ACCESSING REGISTER:000003760306

STARTING *REGISTER DISTURB TESTING*

STARTING *INTERNAL MAINTENANCE MODE (TRANSMITTER) TESTING*

STARTING *INTERNAL MAINTENANCE MODE (RECEIVER) TESTING*

STARTING *SYSTEM & EXTERNAL MAINTENANCE* TESTING

END PASS 1.

EXAMPLE 6.24
DSKMA - KMC11 Diagnostic

SMMAG CMD - DSKMA (CR)

DSKMA DECSYSTEM 2020 KMC11 DIAGNOSTICS
VERSION 0.1, SV=0.2, CPU#=4711, MCV=111, MCO=0, HO=0, KASW=003740 000000

TTY SWITCH CONTROL ? - 0,S OR Y <CR> - 0 (CR)
SWITCHES = 000000 000000

MEMORY MAP =
FROM TO SIZE/K
00000000 01777777 512

'COMMAND MODE' IS INDICATED WHEN THE PROGRAM
TYPES AN "*" AT THE LEFT SIDE OF THE TERMINAL. TO RE-START
FROM 'COMMAND MODE' TYPE "&".
TYPE ? TO GET FORMAT ON (TERMINAL),
OR % TO GET SUMMARY OF CONTROLLER TESTS.

*A (CR)
STARTING REGISTER ACCESS & W-R TESTING
STARTING MICRO PROCESSOR IBUS REG TESTS
STARTING NPR TESTING
STARTING MAIN MEMORY TESTING
STARTING ALU TESTING
STARTING JUMP(I) TESTING MICRO CODE WILL BE MODIFIED
END PASS 1.

CHAPTER 7 REPORTING PROCEDURES

7.1 INTRODUCTION

The job of installation is not complete until the reports are generated. The reports form an important part of the customer history file, and the feedback to regional and corporate quality control is essential to maintaining a check on the quality of installation and pinpointing problem areas when they arise.

7.2 LARS REPORT FORM

The Labor Acceptance Reporting System (LARS) form is the primary method of reporting and may not be substituted by any other form. However, in some instances another installation feedback form may be necessary.

Accuracy is essential when writing LARS forms which are used to gather data for statistics. Therefore, the installer should be familiar with the LARS manual (EK-LARS-FS-00X). This manual has a chapter specifically on installation and how to apply the various codes not usually used during normal PM or on fault-finding calls. Several examples are included for clarification.

Figure 7-1 is a sample LARS form used on a typical DECSYSTEM-2020 installation. To create a valid LARS data base for statistical analysis, the following rules should be applied when filling in blanks.

1. Assigned Person
 - a. The assigned person should use all necessary installation codes and complete the MATERIAL USED and COMMENTS section.
 - b. Unassigned person. This person should duplicate the assigned person's coding if he is plainly assisting on the same device, except for the MATERIALS USED section which he will leave blank and only write in the COMMENTS section: "assisting." However, the unassigned person working on a separate device has the responsibility for reporting this activity.
2. Product Line - There are four LCG product lines and the appropriate designation should be used for a particular system.
 - a. PL66 - Commercial System Group
 - b. PL67 - Education Systems Group
 - c. PL73 - Federal Systems Group (Government/Scientific)
 - d. PL74 - Engineering Systems Group
3. System Type - Enter 2020 in this box to indicate a KS10 based system.
4. System Serial Number - Ensure that the system serial number entered is identical to the CPU serial number.



CUSTOMER NAME
EQUIPMENT LOCATION (CITY AND STATE)

REPORT NO.

1922853

PAGE OF

BADGE NUMBER
MACHINE C.C.
SUB C.C.

ARE YOU THE ASSIGNED PERSON ON CALL? (Y OR N)

CALL COMPLETED? (Y OR N)

LAST NAME
TRAVEL HOURS
REQUEST TIME
DAY MONTH YEAR

PROD. LINE
SYSTEM TYPE
SYSTEM SERIAL NUMBER
START DATE MONTH YEAR

DEC NUMBER (Installation Only)
STOP TIME
DAY MONTH YEAR

ACTIVITY
REPAIR TIME
DEC OPTION

DEC OPTION SER. NO.
MODULE / FAIL AREA / FCO

AUTHORIZED TESTS

TOTAL HOURS

LABOR HOURS PER HOUR

SALES CODE (CIRCLE ONE)

RENTAL DEPOSIT INSTALL PER CALL OTHER

LABOR HOURS PER HOUR

TOTAL LABOR COSTS
TOTAL MATERIAL COST
TRAVEL COST

LINE ITEM	QTY.	CLASS	DEC PART NUMBER B-3-C	VARIATION	T	PART DESCRIPTION VENDOR PART NO.	AMOUNT
TOTAL MATERIAL COST							

CUSTOMER (BILL TO ADDRESS)
STREET
CITY
STATE
ZIP

LABOR HOURS PER HOUR

TOTAL LABOR COSTS
TOTAL MATERIAL COST
TRAVEL COST

SUB TOTAL (ALL SHADED AREAS)
LABOR TAX
MATERIAL TAX

TOTAL

CUSTOMER P.O. NUMBER
BRANCH APPROVAL

CUSTOMER ACKNOWLEDGES RECEIVING THE MATERIALS AND SERVICES INDICATED ON THE FACE OF THIS REPORT AND AGREES TO THE TERMS AND CONDITIONS SET FORTH ON THE REVERSE SIDE OF THIS REPORT.
AUTHORIZED SIGNATURE OF CUSTOMER
PRINT SIGNATURE NAME

BRANCH COPY

Figure 7-1 LARS Report Form

MR-1968

5. DEC Option - Errors can often occur when filling in this box. When working on a 2020 system, use the following option designators.

SYS	Entry for normal system installation(s)
KS10-AA	(60 Hz) for CPU activity
KS10-AB	(50 Hz) for CPU activity
RM03	
RP06	
TU45	
TM02	
UBA	
DZ11	
RH11	
LP20	
LP05	
MS10	

When a variant for the above options exists, as in the KS10, please include it.

6. Activity Codes

NORAM - The new system installation code N should be used from the start of installation until completion of all DIGITAL standard diagnostics (i.e., completion of Chapter 8 of this manual). All activity for the next 90 days, including the hardware and software acceptance periods, shall be booked under code W.

Other Areas - If a day 1 contract after acceptance exists, then the new system installation code (N) should be used from delivery of the system until customer acceptance.

Add-Ons - An add-on should be booked to code N from the start of installation until customer acceptance.

7. Type of Call - Installation code I should be used for all hardware installation.
8. MODULE/FAIL AREA/FCO - This area should contain pertinent data or comments to complement the action code and installation code. If additional comment is necessary, then the COMMENTS section of the LARS form may be used. However, the primary information area should be the MODULE/FAIL AREA/FCO portion.

7.3 DECSYSTEM-2020 INSTALLATION REPORT

The quality assurance group within LCG Corporate Support will selectively include this form with some system shipments. Its purpose is to gain complete installation profiles on one summary sheet and to receive written feedback on the appended device sheets. If such a form is received it should be completed and returned, in the preaddressed envelope provided, to LCG Corporate Quality Assurance.

The report is preceded by some instructions on how to fill out the sections which are not self-explanatory.

7.4 DAILY LOG

To assist in the detailed completion of the above forms, a daily installation activity log should be maintained by the installation supervisor/engineer. If several people are involved in the installation, their daily activity should be noted by the responsible installation engineer to ensure that all work is logged.

7.5 LCG INSTALLATION WARRANTY COSTS SUMMARY FORM

The following descriptions outline the details to be completed in each section of the installation warranty activity form. Refer to Figure 7-2 which is a *sample* of this form.

1. Section 1

- a. Customer – This is the customer name, which is used to reference the system.
- b. System Serial No. – The serial number of the CPU of the system.
- c. Branch – The branch responsible for the system.
- d. Cost Center – This is the cost center of the branch responsible for the system; for example, 7A3.
- e. Product Line (top right-hand corner) – This is the LCG product line which has shipped the system. The four product lines are:

Commercial Systems Group – Product Line 66

Education Systems Group – Product Line 67

Federal Systems Group (Government/Scientific) – Product Line 73

Engineering Systems Group – Product Line 74

2. Section 2

- a. Delivery of System – The day, month, and year of the actual physical delivery of the equipment to the site, whether the site was ready or not. The DIGITAL standard for writing dates is: 15 OCT 76.
- b. Hardware Acceptance – The day, month, and year of the date the system passed the DIGITAL specified hardware acceptance; i.e., before handing over for software installation or before any other customer, or government hardware/software acceptance tests.
- c. Date of Contract – The first day on which the system or add-on equipment is to be covered by a DIGITAL Field Service Maintenance Contract.

3. Section 3

- a. Names of Engineers, Badge Numbers, and Cost Centers – This information is required on *all* the engineers who were concerned with the new system or add-on equipment either in pre-sales visits to the customer, time spent with salespersons, site planning, installation, etc., up to the date the system or add-on was delivered.
- b. Pre-Sales Hours – Any time spent concerned with the delivery or the installation of the new equipment before the actual delivery of that equipment.
- c. Installation Hours – Time spent by the engineers from the date of delivery until the date of hardware acceptance.

- d. Software Installation Hours – Time spent on site by the engineers during the installation of software; i.e., from the date of hardware acceptance until the system is taken over by the customer. This means to the date of contract or until the date of beginning a customer or government prolonged acceptance test with the system being used normally by the customer.
- e. Unusual Installation Hours – This is the period after the completion of software installation during which there may be a customer or government acceptance period, or a reluctance on the part of the customer to sign the field service contract.

When figures are entered in the Unusual Installation Hours column, a brief note on the reasons why it was necessary to record unusual hours should be entered; for example, "system subject to CCA acceptance trial."

4. Section 4

List Options Delivered with Serial Nos. – This section provides a record of the equipment on site; it also serves as a check on the LCG equipment data base.

5. Section 5

List any missing items under the appropriate headings. Missing cosmetic items holding up the acceptance of the system should be noted here.

6. Section 6

Physical Condition of System – A very brief note on the physical condition of the system, paying particular attention to damage rather than the expected good condition; for example, CPU door bent in transit, or door paint scratched. In the event that there was no damage, state "No damage."

7. Section 7

Spares – A brief statement, as appropriate, describing the availability of spares at the time of installation.

8. Section 8

Condition of Site – A brief statement outlining the readiness of the three major site parameters; i.e., physical condition, electrical, and environmental status.

9. Section 9

Installation Faults – Complete this section under the four columns and add extra sheets if necessary. Components or modules which were "dead-on-arrival" should be marked with DOA. Production and quality control consider this information very valuable.

7.6 INSTALLATION/ACCEPTANCE REPORT

Accurate, detailed, and timely installation data is necessary to improve the DECSYSTEM-2020. With this information it will be possible to detect reoccurring problems. Once a problem is identified it will be corrected. This process will contribute to easier and faster installation of future systems.

The form shown in Figure 7-3 is the vehicle for providing the needed information. It should be completed and returned within five days after the hardware acceptance date. The form should be returned to:

Field Service Product Support
MR1-1/S35
Attention: Installation Department

SHEET 2

INSTALLATION AND ACCEPTANCE REPORT

CUSTOMER: _____ SER. #: _____ SYSTEM TYPE: _____

LOC./CC: _____ PREPARED BY: _____ TELE #: _____

DELIVERY DATE: _____ INST. DATE: _____ INST. FINISH: _____

INST. HOURS: _____ SYSTEM REV. LEVEL: _____

INSTALLATION					
CONDITION OF SYSTEM: GOOD ___ FAIR ___ POOR ___					
	NO	YES		NO	YES
1) SITE PREP INCOMPLETE:			11) VOLTAGE ADJ. NEEDED:		
2) SHIPPING DAMAGE:			12) INCORRECT DIAGNOSTIC		
3) PACKING DAMAGE:			VERSIONS:		
4) PAPERWORK INCOMPLETE:			13) ERRORS DURING DIAG. RUN:		
5) DOCUMENTATION INCOMPLETE:			14) HARDWARE PROBLEMS:		
6) ACCESSORIES INCOMPLETE:			15) PROBLEMS UNDETECTED		
7) HARDWARE INCOMPLETE:			BY DIAGNOSTICS:		
8) SYSTEM INTERCONNECTION			16) ADJUSTMENT PROBLEMS:		
PROBLEMS:			17) SOFTWARE PROBLEMS:		
9) PRE-POWER PROBLEMS:			18) ENVIRONMENTAL PROBLEMS:		
10) POWER-UP PROBLEMS:			19) D.O.A. SPARES:		

IF YOU HAVE ANSWERED "YES" TO ANY OF THE ABOVE QUESTIONS -- PLEASE DESCRIBE BRIEFLY ON THE FOLLOWING PAGE.

HARDWARE ACCEPTANCE

DEFINITIONS: KL-BASED SYSTEMS: RUN 72-HOUR KLAB ACCEPTANCE FILE (OR EQUIVALENT)

KS-BASED SYSTEMS: RUN 48-HOURS USER ENVIRONMENTAL TEST PACKAGE.

A) START TIME -- DATE: _____

B) FINISH TIME -- DATE: _____

C) # OF CRASHES/RETRIES: _____

D) HOURS ACCEPTANCE: _____

E) PROBLEM DESCRIPTION (IF ANY): _____

FOLD, STAPLE AND RETURN

MR-1970

Figure 7-3 DECSYSTEM-2020 Installation Report