

# ARCNET Tutorial

# ARCNET®—Embedded Network, Industrial LAN or Fieldbus?

ARCNET was originally classified as a local area network or LAN. A LAN is defined as a group of nodes that communicate to one another over a geographically-limited area usually within one building or within a campus of buildings. That was the intent of ARCNET when it was originally introduced as an office automation LAN by Datapoint Corporation in the late 1970s. Datapoint envisioned a network with distributed computing power operating as one larger computer. This system was referred to as ARC (attached resource computer) and the network, that connected these resources, was called ARCNET.

ARCNET's use as an office automation network has diminished; however, ARCNET continues to find success in the industrial automation industry because its performance characteristics are well suited for control. ARCNET has proven itself to be very robust. ARCNET also is fast, provides deterministic performance and can span long distances making it a suitable fieldbus technology.

The term fieldbus is used in the industrial automation industry to signify a network consisting of computers, controllers and devices mounted in the "field". ARCNET is an ideal fieldbus. Unlike office automation networks, a fieldbus must deliver messages in a time predictable fashion. ARCNET's token-passing protocol provides this timeliness. Fieldbus messages are generally short. ARCNET packet lengths are variable from 0 to 507 bytes with little overhead and, coupled with ARCNET's high data rate, typically 2.5 Mbps, yields quick responsiveness to short messages. Fieldbuses must be rugged. ARCNET has built-in CRC-16 (cyclic redundancy check) error checking and supports several physical cabling schemes including fiber optics. Finally there must be low software overhead. ARCNET's data link protocol is self-contained in the ARCNET controller chip. Network functions such as error checking, flow control and network configuration are done automatically without software intervention.

APPLICATION
PRESENTATION
SESSION
TRANSPORT
NETWORK
DATA LINK
PHYSICAL

In terms of the International Organization of Standards OSI (Open Systems Interconnect) Reference Model, ARCNET provides the Physical and Data Link layers of this model. In other words, ARCNET provides for the successful transmission and reception of a data packet between two network nodes. A node refers to an ARCNET controller chip and cable transceiver connected to the network. Nodes are assigned addresses called MAC (medium access control) IDs and one ARCNET network can have up to 255 uniquely assigned nodes.

### Deterministic Performance

The key to ARCNET's performance and its attractiveness as a control network is its token-passing protocol. In a token-passing network, a node can only send a message when it receives the "token." When a node receives the token it becomes the momentary master of the network; however, its mastery is short lived. The length of the message that can be sent is limited and, therefore, no one node can dominate the network since it must relinquish control of the token. Once the message is sent, the token is passed to another node allowing it to become the momentary master. By using token passing as the mechanism for mediating access of the network by any one node, the time performance of the network becomes predictable or deterministic. In fact, the worst case time that a node takes to deliver a message to another node can be calculated. Industrial networks require predictable performance to ensure that controlled events occur when they must. ARCNET provides this predictability.

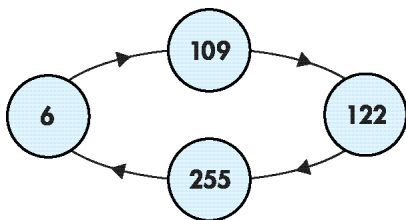
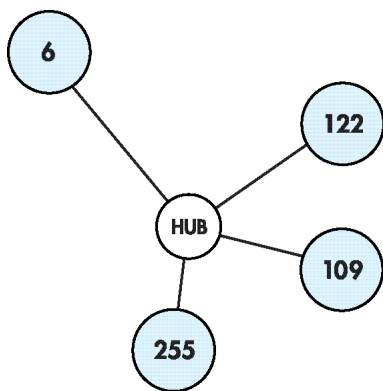

### Logical Ring

A token (ITT—Invitation to Transmit) is a unique signaling sequence that is passed in an orderly fashion among all the active nodes in the network. When a particular node receives the token, it has the sole right to initiate a transmission sequence or it must pass the token to its logical neighbor. This neighbor, which can be physically located anywhere on the network, has the next highest address to the node with the token. Once the token is passed, the recipient (likewise) has the right to initiate a transmission. This token-passing sequence continues in a logical ring fashion serving all nodes equally. Node addresses must be unique and can range from 0 to 255 with 0 reserved for broadcast messages.

For example, assume a network consisting of four nodes addressed 6, 109, 122 and 255. Node assignments are independent of the physical location of the nodes on the network. Once the network is configured, the token is passed from one node to the node with the next highest node address even though another node may be physically closer. All nodes have a logical neighbor and will continue to pass the token to their neighbor in a logical ring fashion regardless of the physical topology of the network.

### Directed Messages

In a transmission sequence, the node with the token becomes the source node and any other node selected by the source node for communication becomes the destination node. First the source node inquires if the destination node is in a position to accept a transmission by sending out a Free Buffer Enquiry (FBE). The destination node responds by returning an Acknowledgement

(ACK) meaning that a buffer is available or by returning a Negative Acknowledgement (NAK) meaning that no buffer is available. Upon an ACK, the source node sends out a data transmission (PAC) with either 0 to 507 bytes of data (PAC). If the data was properly received by the destination node as evidenced by a successful CRC test, the destination node sends another ACK. If the transmission was unsuccessful, the destination node does nothing, causing the source node to timeout. The source node will, therefore, infer that the transmission failed and will retry after it receives the token on the next token pass. The transmission sequence terminates and the token is passed to the next node. If the desired message exceeds 507 bytes, the message is sent as a series of packets—one packet every token pass. This is called a fragmented message. The packets are recombined at the destination end to form the entire message.

### **Broadcast Messages**

ARCNET supports a broadcast message, which is an unacknowledged message to all nodes. Instead of sending the same message to individual nodes one message at a time, this message can be sent to all nodes with one transmission. Nodes that have been enabled to receive broadcast messages will receive a message that specifies node 0 as the destination address. Node 0 does not exist on the network and is reserved for this broadcast function. No ACKs or NAKs are sent during a broadcast message making broadcast messaging fast.

### **Automatic Reconfigurations**

Another feature of ARCNET is its ability to reconfigure the network automatically if a node is either added or deleted from the network. If a node joins the network, it does not automatically participate in the token-passing sequence. Once a node notices that it is never granted the token, it will jam the network with a reconfiguration burst that destroys the token-passing sequence. Once the token is lost, all nodes will cease transmitting and begin a timeout sequence based upon their own node address. The node with the highest address will timeout first and begin a token pass sequence to the node with the next highest address. If that node does not respond, it is assumed not to exist. The destination node address is incremented and the token resent. This sequence is repeated until a node responds. At that time, the token is released to the responding node and the address of the responding node is noted as the logical neighbor of the originating node. The sequence is repeated by all nodes until each node learns its logical neighbor. At that time the token passes from neighbor to neighbor without wasting time on absent addresses.

If a node leaves the network the reconfiguration sequence is slightly different. When a node releases the token to its logical

neighbor, it continues to monitor network activity to ensure that the logical neighbor responded with either a token pass or a start of a transmission sequence. If no activity was sensed, the node that passed the token infers that its logical neighbor has left the network and immediately begins a search for a new logical neighbor by incrementing the node address of its logical neighbor and initiating a token pass. Network activity is again monitored and the incrementing process and resending of the token continues until a new logical neighbor is found. Once found, the network returns to the normal logical ring routine of passing tokens to logical neighbors.

With ARCNET, reconfiguration of the network is automatic and quick without any software intervention.

### Unmatched Cabling Options

ARCNET is the most flexibly cabled network. It supports bus, star and distributed star topologies. In a bus topology, all nodes are connected to the same cable. The star topology requires a device called a hub (passive or active) which is used to concentrate the cables from each of the nodes. The distributed star (all nodes connect to an active hub with all hubs cascaded together) offers the greatest flexibility and allows the network to extend to greater than four miles (6.7 km) without the use of extended timeouts. Media support includes coaxial, twisted-pair and glass fiber optics.

## NIMs and Hubs

### Network Interface Modules

Each ARCNET node requires an ARCNET controller chip and a cable transceiver that usually reside on a network interface module (NIM). NIMs also contain bus interface logic compatible with the bus structure they support. These network adapters are removable and are, therefore, termed “modules.” ARCNET NIMs are available for all the popular commercial bus structures. NIMs differ in terms of the ARCNET controller they incorporate and the cable transceiver supported.

### ARCNET Controllers

The heart of any NIM is an ARCNET controller chip that forms the basis of an ARCNET node. Datapoint Corporation developed the original ARCNET node as a discrete electronics implementation, referring to it as a resource interface module or RIM. Standard Microsystems Corporation (SMSC) provided the first large-scale integration (LSI) implementation of the technology. Since then, other chip manufacturers were granted licenses to produce RIM chips. Today, SMSC and its subsidiary Toyo Microsystems Corporation (TMC) provide the leadership in new ARCNET chip designs.

ARCNET Controllers	
Model	Description
90C26	First generation controller
90C65	XT bus interface
90C98A	XT bus interface
90C126	XT bus interface
90C165	XT bus interface
90C66	AT bus interface
90C198	AT bus interface
20010	Microcontroller interface
20019	Microcontroller interface
20020	Microcontroller interface
20022	Microcontroller interface
20051	Integral microcontroller
20051+	Integral microcontroller

### Use of Hubs

Hubs facilitate cabling by interconnecting multiple NIMs and, in most cases, they exercise no control over the network. The primary function of a hub is to provide a convenient method of expanding a network. There are two types of hubs that can perform this task—a passive hub or an active hub.

**Passive Hubs**—Passive hubs are inexpensive, require no power and their sole purpose is to match line impedances, which they do with resistors. These hubs usually have four ports to connect four coaxial star transceivers. One of the disadvantages of these hubs is that they limit the network to 200 feet and each segment of the network to 100 feet. Also, unused ports must be terminated with a 93 ohm resistor for proper operation. Passive hubs are used on small (four nodes or less) coaxial star networks.

**Active Hubs**—Active hubs are essentially electronic repeaters. Although they require power, active hubs support all cabling options, support longer distances than passive hubs, provide isolation and guard against cabling faults and reflections. These are the hubs which are used to cable distributed star networks.

Unused ports on an active hub need not be terminated. Unlike passive hubs, active hubs do not attenuate signals and can be cascaded. A cable failure will affect only one port on an active hub. Active hubs are available as either internal or external devices. Internal hubs reside inside a computer that also has a NIM, while external hubs are stand-alone devices.

Active hubs can be configured as two port devices as well. A link is a two port device with differing cable options on each port allowing for the transition of one medium type to another such as coaxial to fiber conversion. A repeater is a two-port device of the same cable option.

## Topologies

### Multiple Topologies

Topology refers to the arrangement of cables, NIMs and hubs within a network. With ARCNET, there are several choices. Once the topology is specified, the selection of transceivers can proceed.

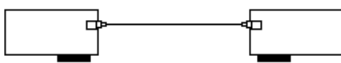

**Point-To-Point**—In the point-to-point connection, only two NIMs are used. This is the simplest of networks. Each NIM effectively terminates the other NIM; therefore, no hub is required.

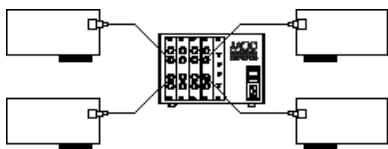

**Star**—The star connection requires hubs. Each NIM connects to one point on the hub that effectively terminates the connected NIM. Since only one NIM is connected to any one hub port, faults in a cable or at a node can be easily isolated. Cabling a facility is often easier with a star topology.

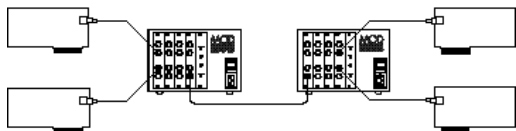

**Distributed Star (Tree)**—If several active hubs are used, a distributed star topology can be implemented. This topology is the most flexible cabling method available in ARCNET LANs since both node-to-hub and hub-to-hub connections are supported. Two or more active hubs, each supporting a cluster of connected nodes, are linked together by a “home run” cable.

The distributed star topology helps reduce cabling costs since each node connects to a local hub, thereby eliminating the need to run each node’s cable over to one wiring location. Like the star configuration, nodes are isolated from one another.

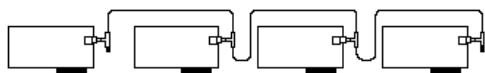

**Bus**—In the bus configuration, NIMs equipped with high impedance transceivers or EIA-485 drivers must be used. Using RG-62/u coaxial cable and BNC “tees,” or twisted-pair cable, several NIMs can be connected without the use of a hub. Termination is provided by the installation of a resistive terminator at both ends of the cable segment. The advantage of this configuration is that no hub is required. The disadvantage is that one node failure could disrupt the complete network. Also, cabling distances are less than the star or point-to-point connection.

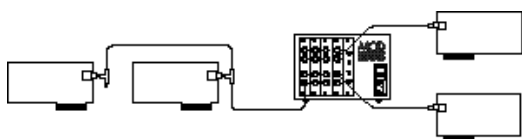

**Star/Bus**—To bridge a bus topology to a star requires an active hub. In this case, the active hub acts as both a terminator for the bus and a repeater for the network. Remove the passive terminator from one end of the bus and connect that end to one port on the active hub. Other ports on the active hub can now be used for other bus or star connections.

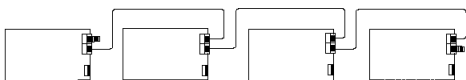

**Daisy-Chain**—Daisy chaining of NIMs requires two connectors or a single connector with redundant connections per NIM. Internally the two connections are bussed together and, therefore, do not truly represent a daisy-chain connection but that of a bus. Daisy chaining is best used with RJ-11 connectors. The unused connectors at each end of the daisy-chain can then be used with RJ-11 style terminators.

**Multidrop**—A multidrop topology is a variation of the bus topology where a short “drop” cable from the tee connection is allowed. There has not been any study on the effects and limitation of drop cables so this topology is not allowed.

**Ring**—ARCNET does not allow for a ring or a loop connection. Unreliable operation of the network will be experienced if a loop is implemented or if a distributed star topology is violated by introducing a loop connection back to any one node.

---

## Transceivers

### Transceiver Options

Various types of transceivers are available depending upon the topology and cable selected. Usually a suffix is appended to the model number of the product to identify which transceiver exists with that product. This practice is utilized on both active hub and network interface modules.

**Coaxial Star**—Typically, ARCNET is cabled with RG-62/u coaxial cable (with BNC connectors) in a star topology, each NIM connects directly to a port on an active or passive hub. Alternatively, RG-59/u coaxial cable can be used, but at a cost of reduced distances between a node and a hub. Overall, coaxial cable offers good performance, good noise immunity, low propagation delay, low signal attenuation, sufficient ruggedness and low cost. The coaxial star configuration also provides the longest coaxial distance and simplified troubleshooting.

**Coaxial Bus**—RG-62/u coaxial cable can be used in a bus configuration using BNC tee connectors with passive terminators at each end of the cable. Although hubs are not required, cabling options are restricted and troubleshooting is much more difficult. There is a minimum distance between adjacent nodes. Coaxial bus is used when reliable coaxial cable communication is required in a hubless system when shorter distances are involved.

**Twisted-Pair Star**—Unshielded twisted-pair wiring such as IBM Type 3 (#24 or #22 AWG solid copper twisted-pair cable or telephone wiring) can be used. BALUNs are required at both the hub and NIM to use this cable. Some twisted-pair NIMs and hubs have internal BALUNs, so external BALUNs are not needed. Twisted-pair is convenient to install. However, its attenuation exceeds coaxial, its noise immunity is less, and its maximum length between a node and a hub is lower. RJ-11 connectors are often used with this cable.

**Twisted-Pair Bus**—The convenience of twisted-pair wiring can be used in a bus configuration without the use of BALUNs. Dual RJ-11 jacks are provided so modules can be wired in a “daisy-chain” fashion even though electrically they are connected as a bus. Distances are limited as well as node count. Passive



terminators are inserted in unused jacks at the far end of the segment. For small hubless systems this approach is attractive.

**Glass Fiber Optics**—Duplex glass, multimode fiber optic cable uses either SMA or ST™ connectors and is available in three sizes measured in microns: 50/125, 62.5/125 and 100/140. Larger core sizes launch more energy allowing longer distances. The industry appears to have selected 62.5/125 as the preferred size. This core size, operating with 850 nm transceivers, provides long distances, reasonable cost, immunity to electrical noise, lightning protection and data security. Glass fiber optic cable is used in hazardous areas and interbuilding cabling on campus installations or whenever metallic connections are undesirable. Connectors can be either SMAs or STs. The STs look like a small BNC and are more tolerant to abuse than SMA. ST connectors have become more popular than the traditional SMA connector.

For very long distances up to 14 km, single mode fiber optics operating at 1300 nm is recommended. Cable attenuation is much less at 1300 nm than at 850 nm.

**DC Coupled EIA-485**—One popular cabling standard in industrial installations is EIA-485. A single twisted-pair supports several nodes over a limited distance. Screw terminal connections or twin RJ-11 jacks are provided so that the modules can be wired in a “daisy-chain” fashion. EIA-485 offers a hubless solution, but with limited distance and low common mode breakdown voltage.

**AC Coupled EIA-485**—The EIA-485 transformer coupled option provides the convenience of EIA-485 connectivity, but with a much higher common mode breakdown voltage. Distances and node count are reduced from the DC coupled EIA-485 option. The AC coupled option is insensitive to phase reversal of the single twisted-pair that connects the various nodes but may not operate over the full range of data rates of the newer ARCNET controllers.

## Cable

Once the topology and transceiver are specified, the cable can be selected. There are basically three choices in cabling: coaxial, twisted-pair and fiber optic. Each type has its advantages and when using active hubs all three types of cabling can be mixed within one network—an example of ARCNET’s extreme flexibility.

**Coaxial Cable**—RG-62u was the original choice for cabling ARCNET systems, and is recommended over RG-59/u if possible. RG-62/u (93 ohm) is a better impedance match to the coaxial transceiver and has less attenuation than RG-59/u (75 ohm) yielding greater distances. Standard BNC connectors and tees are

used. Coaxial cable is relatively inexpensive and provides the highest propagation factor compared to other alternatives.

***Twisted-Pair***—Unshielded twisted-pair cabling can be used with several transceivers including those for EIA-485. We recommend IBM type 3 (although other unshielded twisted-pair cable with similar characteristics will also work). Twisted-pair cable is inexpensive and convenient to use and easy to terminate. However, twisted-pair cable has much greater attenuation than coaxial cable and, therefore, has limited distance capability.

***Fiber Optics***—Fiber offers the greatest distance but requires more attention to its application. There are many varieties of cables and cable pairs. The use of 62.5/125 duplex cable for conventional installations and single mode for long distances is suggested. For indoor applications tight buffering is recommended and for outdoor applications loose buffering is recommended. Study the attenuation figures for the specified fiber to ensure that it is within the available power budget. Fiber optics can span the greatest distance, but has a lower propagation factor than coaxial cable. It may be necessary to calculate the resulting signal delay to ensure it is within ARCNET limits.

#### **Electrical Code**

Cable installations must comply with both federal and local ordinances. Plenum-rated (within air distribution systems) and riser-rated (between floors) cables are available, but at a higher cost, to meet the requirements of the National Electric Code (NEC). Consult the relevant documents for applicability when installing an ARCNET network.

## **Coaxial Cable Offers Good Price/Performance**

---

The original ARCNET specification called for RG-62/u coaxial cable as the medium between hubs and NIMs. With the desire to eliminate hubs, the bus transceiver was developed but RG-62/u coaxial cable remained as the specified cable. Therefore, there are two transceivers: coaxial star for distributed star systems and coaxial bus for hubless systems.

#### **P1, P2 Signaling**

All ARCNET controller chips develop two signals called P1 and P2 that drive the coaxial transceiver (sometimes referred to as the hybrid). Both P1 and P2 are negative true signals of 100 nanoseconds in duration with P2 immediately following P1 when operating at the default 2.5 Mbps data rate. These signals occur when an ARCNET controller transmits a logic “1.” If a logic “0” is

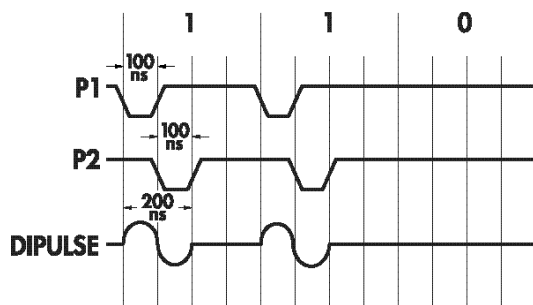

to be transmitted, no pulses are sent and the line remains idle. The sum of P1 and P2 is 200 nanoseconds; however, one signaling interval of ARCNET requires 400 nanoseconds. The remaining 200 nanoseconds are absent of signaling. A center-tapped transformer is wired to two drivers connected to P1 and P2. When P1 is received by the transceiver, the coaxial cable is driven in a positive direction for the duration of the pulse. When P2 is received by the transceiver, the coaxial cable is driven in a negative direction for the duration of the pulse. The resulting signal is called a dipulse that approximates a single sine wave. Since this all occurs over a 200 nanosecond interval, the waveshape appears as a 5 MHz signal instead of 2.5 MHz which is what we would expect with ARCNET. Therefore, cable attenuation calculations should be made at 5 MHz instead of 2.5 MHz. Since the dipulse has no DC component, transformer operation is simplified.

#### Star vs. Bus

The coaxial star transceiver and the coaxial bus transceiver both receive P1 and P2 signals and generate dipulse signals. However, the star transceiver represents a low impedance (approximately 93 ohms) at all times while the bus transceiver represents a high impedance when idle allowing for multiple transceivers to be attached to a common bus. Since the two transceivers have a similar appearance, it is important to distinguish one from another. The following practice is recommended for identification purposes. For star transceivers, use black bodied BNC connectors on the printed-circuit board. For bus transceivers, use white.

The capabilities of the two transceivers differ significantly. The star transceiver can drive 2000 feet (610 m) of RG-62/u cable while the bus can only drive 1000 feet (305 m). However, the bus transceiver can support eight nodes on a single segment. Connections between nodes are made with BNC tee connectors and coaxial cables of at least six feet (2 m) in length. Passive termination is required at the ends of bus segments. The isolation of the two transceivers is typically 1000 volts DC.

## Twisted-Pair—Inexpensive and simple to use

Twisted-pair is also a popular cabling technology. It is inexpensive and easy to terminate. However, it has much higher attenuation than coaxial cable limiting its use to shorter distances. Frequently, modular jacks and plugs are used to interconnect segments. Twisted-pair cable can be used with conventional coaxial star transceivers if a BALUN is used between the cable and the transceiver. A MUX LAB 10070 is recommended for use as an external BALUN. It has a male BNC connector at one end and a RJ-11 jack at the other, and it must be used only with coaxial star

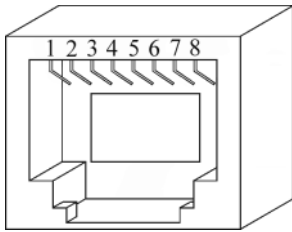

Modular Connector Pin Assignments					
4-Contacts		6-Contacts		8-Contacts	
Pin	Usage	Pin	Usage	Pin	Usage
1		1		1	
2	LINE-	2		2	
3	LINE+	3	LINE-	3	
4		4	LINE+	4	LINE-
		5		5	LINE+
		6		6	
				7	
				8	

transceivers. For convenience, some vendors provide a product that eliminates the need for external BALUNs. The twisted-pair star transceiver incorporates an internal BALUN along with a coaxial star transceiver together as one unit. Simply connect to the provided RJ-11 jack. When using BALUNs, only star and distributed star topologies are supported. No phase reversal of the wiring is allowed. Many modular plug patch cables invert the wiring. To test for this, hold both ends of the cable side by side with the retaining clips facing the same direction. The color of the wire in the right-most position of each plug must be the same if there is no inversion of the cable. If this is not the case, the cable is inverted.

### Twisted-Pair Bus

For hubless systems, twisted-pair bus transceivers can be used. Since modular jacks are used and a bus connection is required, two jacks, internally wired together, are provided on each NIM. Field connections are then made in a daisy-chain fashion to each successive NIM. The remaining end jacks are then plugged with passive terminators. A modular plug terminator is available for this use. Each daisy-chain cable must not invert the signals and must be at least six feet long for reliable operation.

Hubs can be used to extend twisted-pair bus segments. Use a twisted-pair star hub port in place of the passive terminator at one end of the segment. Connect this last port on the NIM to the twisted-pair star port on the hub using an “inverted” modular plug cable. This is necessary since the BALUN in the twisted-pair star port creates a signal inversion that is not compatible with the twisted-pair bus port. The interconnecting inverted cable “rights” the signal. Connect the second twisted-pair bus segment in a similar fashion using an additional twisted-pair star port.

### Data Rate Selection

Conventional ARCNET NIMs communicate only at a 2.5 Mbps rate. Newer generation COM20019, COM20020, COM20022, COM20051 ARCNET controllers have a prescaler that allows communication at other speeds. Although lower data rates facilitate longer bus segments, variable speed hub electronics are required to service these rates. Of course, for hubless systems this is not a problem. Data rates down to 19 kbps are possible with the 20019 controller and as high as 10 Mbps with the 20022. Do not change the data rate on systems with dipulse transceivers since the transceiver is tuned to 2.5 Mbps and can only operate at that data rate.

### Backplane Mode

The COM20019, COM20020, COM20022, COM20051 ARCNET controller family offers additional interfaces not available in earlier

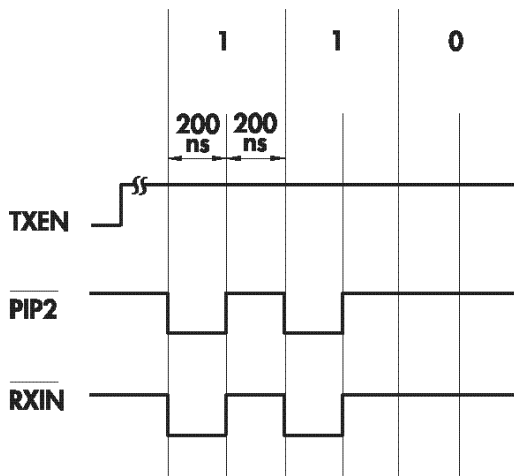

generation controllers. Upon power up, the chips default to conventional ARCNET mode where P1 and P2 signals are generated to develop the required dipulse signal. However, if backplane mode is programmed into these chips, the P1 signal is stretched into a 200-nanosecond signal and P2 becomes a clock. The sense of the receiver pin (RXin) is inverted so that it may be tied directly to the negative true P1. In the simplest configuration, the P1 and RXin pins of all the controllers that are to communicate to one another are tied together using a single pull-up resistor. The bus segment must remain extremely short limiting this configuration to applications of several nodes communicating within one instrument. However, the distances can be extended significantly if driver and receiver electronics are inserted between the P1 signal and RXin. A logical choice would be EIA-485 due to the popularity of the standard. To implement a party line EIA-485 requires one additional signal called TXEN that is generated by the newer chips. This signal is ignored in conventional dipulse mode and unavailable on earlier ARCNET controllers.

## EIA-485—A popular industrial standard

EIA-485 standard supports multimaster operation and is, therefore, suitable for use with ARCNET in either backplane or non-backplane modes. Non-backplane mode implementations require an extended P1 signal and the generation of TXEN. Two EIA-485 implementations are supported on ARCNET, DC-coupled and AC-coupled. The capabilities of each approach are different.

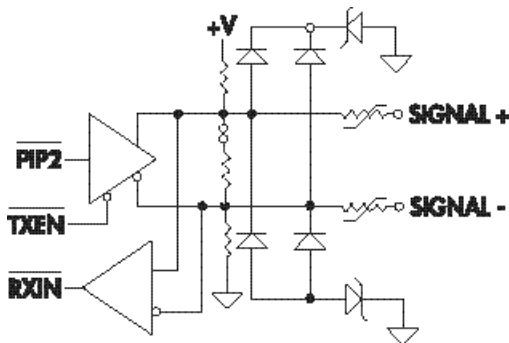

### DC Coupled 485

The original EIA-485 specification deals with the problem of data transmission over a balanced transmission line in a party-line configuration. With ARCNET, any node can transmit; therefore, multiple drivers and receivers share a common twisted-pair cable. EIA-485 does not specify a data link protocol and, therefore, a means must be provided that ensures only one driver has access to the medium at any one time. ARCNET provides its own medium access control (MAC), and it is used to successfully implement the EIA-485 network.

Standard Microsystems Corporation has made recommendations on how to implement EIA-485 with ARCNET. They studied reflections, signal attenuation and DC loading. Since EIA-485 does not specify a modulation method or cabling, rules need to be developed for ARCNET based EIA-485 networks.

In order to reduce reflections, it is necessary to terminate the cable in its characteristic impedance. Since the driver can be located anywhere along the network, a terminator must be supplied at

both ends of the cable. It is recommended that unshielded or shielded twisted-pair cable with characteristic impedance of 100 to 120 ohms be used. Therefore, matching terminators must reside at each end of the segment.

Only one driver is enabled at any one time in an operating network; however, there are times when no drivers are operational causing the twisted-pair cable to float. Noise and reflections along the line can cause the various receivers to incorrectly detect data creating data errors. These receivers need to be biased into their “off” state to ensure reliable operation. Decreasing the bias resistance improves immunity to reflections but can load the drivers excessively. Also, the amount of bias required increases with the number of receivers on the line. Since differential receivers are used, both pull-up and pull-down resistors are required to properly bias the receivers. Through experimentation, SMSC recommends an optimal biasing resistor of 810 ohms. It is recommended that this resistance be distributed over two modules—each located at the ends of a segment in order to simplify the cabling rules. The modules at the ends of the segment will be strapped for biasing resistors and a line terminator while all other modules will have no biasing or termination. Since two modules are being used to supply bias, their resistors will be increased to 1600 ohms. With this approach, a total of 17 nodes can share a single segment up to 900 feet (274 m) in length.

Although differential line drivers and receivers are used, this fact does not remove the need for a common ground among all the nodes. A cold water pipe connection is a possibility. The common mode voltage experienced by any one node should not exceed  $\pm 7$  volts. A good grounding system would ensure that this requirement is met.

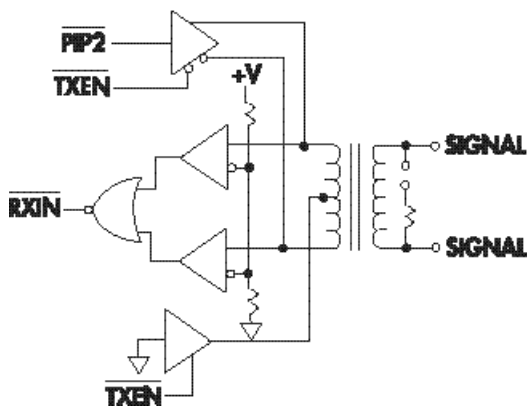

#### AC Coupled EIA-485

One method to achieve a much higher common mode rating is to transformer couple the EIA-485 connection. SMSC has developed such an approach achieving a common mode rating of 1000 volts DC. This implementation does not require biasing resistors, as does the DC coupled approach; however, line terminators must still be applied at each end of the cable segment. The AC coupled EIA-485 approach has the additional advantage that connections to each node are insensitive to phase reversal. This is because the symbol on the cable reverses polarity on successive logic “1”s. Polarity of the wiring need not be observed. However, this implementation is rated at 13 nodes maximum over 700 feet (213 m) of cable.

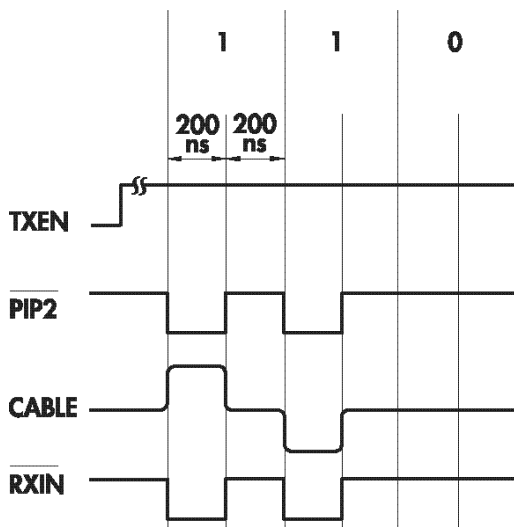

Extending bus segments beyond the 700 or 900 foot (213–274 m) limit is possible with the introduction of active hubs.

AC coupled design may not operate over all data rates so the vendor specifications should be studied.

#### Termination

A benefit of using active hubs is that no passive-termination is required at each port nor must unused ports be terminated. Only bus segments of either coaxial or twisted-pair cabling require termination. Termination for twisted-pair cable includes EIA-485. In general, passive termination equal to the characteristic impedance of the cable needs to be applied at each end of the bus segment. If one end of the bus segment attaches to a port on an active hub, no termination is required at that end.

For RG-62/u cable, use a 93 ohm terminator attached to a BNC tee connector. For twisted-pair cable, use a matching terminator that plugs into the unused RJ-11 connector at each end of the bus segment. If no RJ-11 connector exists, use a discrete resistor attached to screw terminals or with some NIMs—an onboard terminator can be invoked by inserting a jumper.

## Applying Fiber Optics to Achieve a Robust Design

The use of fiber optics in LANs, such as ARCNET, has increased due to the inherent advantages of using fiber. High data rates can be maintained without electromagnetic or radio frequency interference (EMI/RFI). Longer distances can be achieved over that of copper wiring. For the industrial/commercial user, fiber offers high-voltage isolation, intrinsic safety and elimination of ground loops in geographically large installations. ARCNET will function with no difficulty over fiber optics as long as some simple rules are followed.

There are varying types of fiber optic cabling, but basically the larger size fiber (in diameters of 50, 62.5 and 100 microns for conventional installations) is recommended. With this size fiber, multimode operation will be experienced requiring the use of graded index fiber. Transceivers operating at 850 nm wavelength offer a good performance/cost tradeoff.

A duplex cable is required since each fiber optic port consists of a separate receiver and transmitter which must be cross-connected to the separate receiver and transmitter at the distant end. Only star and distributed star topologies are supported.

For distances beyond 3 km, single mode fiber optics used with 1300 nm transceivers is recommended. With this approach, segment lengths up to 14 Km can be realized.

### Optical Power Budget

When specifying a fiber optic installation, attention must be paid to the available optical power budget. The power budget is the ratio of the light source strength to the light receiver sensitivity expressed in dB. This value must be compared to the link loss budget that is based upon the optical cable and optical connectors. The link loss budget must be less than the power budget. The difference is called the power margin which provides an indication of system robustness.

Optical Power Budget (25°C)		
Fiber Size		
(microns)	850 nm-dBm	1300 nm-dBm
Single mode	N/A	13.0
50/125	6.6	21.0
62.5/125	10.4	22.0
100/140	15.9	N/A
200/230PCS	9.4	N/A

Minimum Transmitter Output Power (25°C)			
Fiber Size	NA	Xmit Power	Xmit Power
(microns)	(Numerical)	850 nm-dBm	1300 nm-dBm
	Aperture		
Single mode	N/A	N/A	-22.0
50/125	0.200	-18.8	-14.0
62.5/125	0.275	-15.0	-13.0
100/140	0.300	-9.5	N/A
200/230PCS	0.400	-16.0	N/A

Minimum Receiver Sensitivities (25°C)		
Fiber Size	Sensitivity	Sensitivity
(microns)	850 nm-dBm	1300 nm-dBm
Single mode	N/A	-35.0
50/125	-25.4	-35.0
62.5/125	-25.4	-35.0
100/140	-25.4	-35.0
200/230 PCS	-25.4	N/A

Transmitter power is typically measured at one meter of cable and, therefore, includes the loss due to at least one connector. The outputs vary so each device should be tested to ensure that a minimum output power is achieved. The output power also varies with core sizes. In general, larger cores launch more energy.

Receiver sensitivity also varies so tests should be run to determine the least sensitive receiver. The difference between the weakest transmitter and least sensitive receiver is the worst case power budget that should be specified. Realized power budgets will exceed this value since the probability of the worst case transmitter being matched with the worst case receiver is remote. However, it is recommended to use the stated power budgets for each core size.

### Link Loss Budget

The cable manufacturer usually specifies the fiber optic cable attenuation for different wavelengths of operation. Use this figure to determine the maximum distance of the fiber link. It is necessary to include losses due to cable terminations. Connectors usually create a loss of from 0.5 to 1 dB. For example, assume a 1500 meter run of 62.5 cable that the manufacturer specifies as having an attenuation of 3.5 dB per 1000 meters. The cable loss will be 5.25 dB. Assuming two connector losses of 0.5 dB each, the link loss budget would be 6.25 dB which is within the 10.4 dB power budget specified. The 5.15 dB difference represents a high degree of margin. A 3 dB margin is what is typically recommended.

### Overdrive

Overdrive occurs when too little fiber optic cable is used resulting in insufficient attenuation. To correct this condition, a jumper is typically removed in each fiber optic transceiver to reduce the gain



## Calculating Permissible Segment Lengths

---

sufficiently to allow for a zero length of fiber optic cable to be installed between a transmitter and receiver. This is potentially a problem with 100 micron cable.

A segment is defined as any portion of the complete ARCNET cabling system isolated by one or more hub ports. On a hubless or bus system, the complete ARCNET cabling system consists of only one segment with several nodes, however, a system with hubs has potentially many segments. An ARCNET node is defined as a device with an active ARCNET controller chip requiring an ARCNET device address. Active and passive hubs do not utilize ARCNET addresses and, therefore, are not nodes. Each segment generally supports one or more nodes but in the case of hub-to-hub connections, there is the possibility that no node exists on that segment.

The permissible cable length of a segment depends upon the transceiver used and the type of cable installed. The following table provides guidance on determining the constraints on cabling distances as well as the number of nodes allowed per bus segment.

The maximum segment distances were based upon nominal cable attenuation figures and worst case transceiver power budgets. Assumptions were noted.

When approaching the maximum limits, a link loss budget calculation is recommended.

When calculating the maximum number of nodes on a bus segment, do not count the hub ports that terminate the bus segment as nodes. However, do consider the maximum length of the bus segment to include the cable attached to the hub ports.

Several bus transceivers require a minimum distance between nodes. Adhere to this minimum since unreliable operation can occur.

ARCNET's data link protocol is fully described in ANSI/ATA 878.1

**Permissible Cable Lengths and Nodes Per Segment**

Transceiver Description	Cable	Connectors	Cable Length		Max Nodes Bus Segment	Notes
			Min	Max		
coaxial star	RG-62/u	BNC	0	2000ft/610m	N/A	5.5 dB/1000ft max
coaxial star	RG-59/u	BNC	0	1500ft/457m	N/A	7.0 dB/1000ft max
coaxial bus	RG-62/u	BNC	6ft/2m <sup>1</sup>	1000ft/305m	8	5.5 dB/1000ft max
duplex fiber optic (850 nm)	50/125	SMA or ST	0	3000ft/915m	N/A	4.3 dB/km max
duplex fiber optic (850 nm)	62.5/125	SMA or ST	0	6000ft/1825m	N/A	4.3 dB/km max
duplex fiber optic (850 nm)	100/140	SMA or ST	0 <sup>2</sup>	9000ft/2740m	N/A	4.0 dB/km max
duplex fiber optic (1300 nm)	single mode	ST	0	46000ft/14000m	N/A	0.5 dB/km max
duplex fiber optic (1300 nm)	50/125	ST	0 <sup>2</sup>	32800ft/10000m	N/A	1.5 dB/km max
duplex fiber optic (1300 nm)	62.5/125	ST	0 <sup>2</sup>	35000ft/10670m	N/A	1.5 dB/km max
twisted-pair star	IBM type 3	RJ-11	0	330ft/100m	N/A	uses internal BALUNs
twisted-pair bus	IBM type 3	RJ-11, screw	6ft/2m <sup>1</sup>	400ft/122m	8	
DC coupled EIA-485	IBM type 3	RJ-11, screw	0	900ft/274m	17	DC coupled
AC coupled EIA-485	IBM type 3	RJ-11, screw	0	700ft/213m	13	transformer isolated

<sup>1</sup> This represents the minimum distance between any two nodes or between a node and a hub.

<sup>2</sup> May require a jumper change to achieve this distance.

**Data Link Layer**

Local Area Network: Token Bus (2.5 Mbps) and copies are available from the ATA office. ARCNET is properly classified as a token bus technology since a token is the primary means of mediating access to the cable. It operates under the source/destination model since the destination of the message must be identified during a transmission. The term bus implies that each ARCNET node is capable of monitoring all the traffic on the network regardless of destination. This is important when the network is being reconfigured or the detection of a lost token is to be determined. Even when hubs are being used, it is important that all nodes on the network are capable of monitoring all the traffic on the network in order for ARCNET's data link layer to function properly.

Conventional ARCNET operates at 2.5 Mbps and much of the timing information presented assumes that speed. At this speed, a signal element on the medium must occur within 400 ns. For a logic 1 the symbol is a dipulse. For a logic 0 there is the absence of a dipulse. Putting symbols together creates basic symbol units.

**Basic Symbol Units**

Basic symbol units are the elements used to construct basic frames and reconfiguration bursts.

**<SD>**—Starting Delimiter

1 1 1 1 1 1 (6 symbols)

All ARCNET frames begin with six logic 1s.

This is referred to as the Alert Burst.

**<RSU>**—Reconfiguration Symbol Unit

1 1 1 1 1 1 1 1 0 (9 symbols)

**<ISU>**—Information Symbol Unit

1 1 0 d0 d1 d2 d3 d4 d5 d6 d7 (11 symbols)

Each information unit contains 8 bits of data and a 3-bit preamble 1 1 0. The definition and value of the data are as follows:

**<SOH>**—Start of Header 0x01

Used to identify a packet

**<ENQ>**—Enquiry 0x85

Used to identify a request for a free buffer

**<ACK>**—Acknowledgement 0x86

Used to identify acceptance

**<NAK>**—Negative Acknowledgement 0x15

Used to identify non-acceptance

**<EOT>**—End of Transmission 0x04

Used to identify a token pass to the logical neighbor.

**<NID>**—Next Node Identification 0x01 to 0xFF

Used to identify the next node in the token loop. The NID is the logical neighbor of the node with the token.

**<SID>**—Source Node Identification 0x01 to 0xFF

Used to identify the source node of a packet transmission.

**<DID>**—Destination Node Identification 0x00 to 0xFF

Used to identify the destination node of a transmission request or a packet transmission.

**<CP>**—Continuation Pointer 0x03 to 0xFF

Used to identify the length of packet. In short packet mode (0 to 252 bytes), the CP requires only one ISU. In long packet mode (256 to 507 bytes), the CP requires two ISUs.

**<SC>**—System Code 0x00 to 0xFF

Used to identify a high level protocol. System codes generally require one ISU but two ISU system codes exist. System codes have been assigned by Datapoint Corporation. The ARCNET Trade Association has a list of system code assignments.

**<...DATA...>**—Data

Contains the user data. The number of ISUs can range from 0 to 252 in short packet mode and 256 to 507 in long packet mode. Packets which contain 253, 254 or 255 ISUs cannot be sent. Packets of this size are called exception packets and must be padded with null data and sent as a long packet.

**<FCS>**—Frame Check Sequence 0x00 to 0xFFFF

Contains the appended cyclic redundancy check (CRC-16) for the packet sent. Two ISUs are required.

Invitation to Transmit (ITT)		
SD	6 bits = 2.4	μs
EOT	11 bits = 4.4	
NID	11 bits = 4.4	
NID	11 bits = 4.4	
	15.6	μs

Free Buffer Enquiry (FBE)		
SD	6 bits = 2.4	μs
ENQ	11 bits = 4.4	
DID	11 bits = 4.4	
DID	11 bits = 4.4	
	15.6	μs

Acknowledgment (ACK)		
SD	6 bits = 2.4	μs
ACK	11 bits = 4.4	
	6.8	μs

Negative Acknowledgment (NAK)		
SD	6 bits = 2.4	μs
NAK	11 bits = 4.4	
	6.8	μs

Short Packet (PAC)		
SD	6 bits = 2.4	μs
SOH	11 bits = 4.4	
SID	11 bits = 4.4	
DID	11 bits = 4.4	
DID	11 bits = 4.4	
CP	11 bits = 4.4	
SC	11 bits = 4.4	
*n Characters	nx11 bits = 4.4 n	
FCS	22 bits = 8.8	
	37.6	
	+ 4.4 n	μs

\*1 less than the number of bytes following CP

Long Packet (PAC)		
SD	6 bits = 2.4	μs
SOH	11 bits = 4.4	
SID	11 bits = 4.4	
DID	11 bits = 4.4	
DID	11 bits = 4.4	
CP	22 bits = 8.8	
SC	11 bits = 4.4	
*n Characters	nx11 bits = 4.4 n	
FCS	22 bits = 8.8	
	42.0	
	+ 4.4 n	μs

\*1 less than the number of bytes following CP

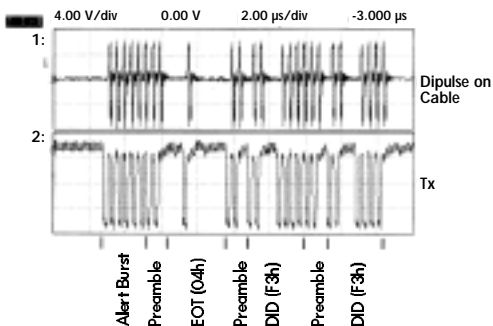

### Frame Format

There are two frame formats with ARCNET. The basic frame format provides control and information between the nodes while the reconfiguration burst is unique to the reconfiguration process. Frames are constructed by putting together basic symbol units.

### Basic Frames

There are only five basic frames in the ARCNET data link layer protocol. The five basic frames are as follows:

**ITT**—Invitation to Transmit (token)

<SD><EOT><NID><NID>

**FBE**—Free Buffer Enquiry

<SD><ENQ><DID><DID>

**ACK**—Acknowledgement

<SD><ACK>

**NAK**—Negative Acknowledgement

<SD><NAK>

**PAC**—Packet

<SD><SOH><SID><DID><DID><CP><SC><...DATA...><FCS>

There are a few things to notice with these five frames. When passing the token, the NID is sent twice. Likewise, the DID is sent twice when requesting a transmission or sending a packet. The source of an ACK or NAK is not identified. It is implied to come from the destination node. The only time the source node is identified is during a packet transmission. It is not sent during an FBE. It is implied that an FBE comes from the source node.

### System Codes

The byte immediately following the continuation pointer in every ARCNET packet must be a system code that acts as a protocol identifier. This allows a number of protocols using independent message formats to coexist on a single physical network. Every packet must have a system code even if no nodes support multiple protocols to allow more than one node type on the network.

System code 0x80 is reserved for general-purpose diagnostic use. Any node can send a packet with system code 80 at any time. Any node receiving a packet with system code 80 ignores the packet.

System codes for different operating systems and manufacturers have been assigned by Datapoint Corporation.

### Reconfiguration Burst

The reconfiguration burst is a special frame only used in the reconfiguration process. It is a jam signal of sufficient length to destroy any activity occurring on the network ensuring that all nodes are aware that a reconfiguration of the network will take place.

#### RECON—Reconfiguration Burst

<RSU><RSU>...<RSU> 765 RSUs

## Deterministic Transmission Times

### Delay Constants

Since ARCNET uses a token passing means to arbitrate station access to the medium, the time it takes to transmit messages is predictable. In order to make these calculations, it is necessary to understand certain delays inherent in the ARCNET controller and the cable used to interconnect the various stations. The delays due to the ARCNET controller are scalable to the data rate used. The delays at 5 Mbps are half as much as the delays at 2.5 Mbps. The delays due to cabling are not scalable. What follows are the delays for conventional ARCNET operating at 2.5 Mbps.

#### Tta—Turnaround Time

The ARCNET controller chip has a response time of about 12.6µs. This is the time between the end of a received transmission and the start of a response to that transmission.

#### Tpt—Medium Propagation, Token Pass to Logical Neighbor

The medium propagation time is the time it takes for the transmission of a symbol from one point to the receipt of the same symbol at another point. The medium propagation constant varies with the type of media used. In the case of coaxial cable use 4 ns/m; for fiber optics use 5 ns/m; and for twisted-pair use 5.5 ns/m. Therefore the length of the medium between transmitter and receiver must be known or approximated for calculation purposes. Sometimes an average length is used to simplify calculations. The parameter Tpt refers to the time it takes for a symbol to travel from the node with the token to its logical neighbor. For standard timeouts Tpt should not exceed 31µs. Remember that this is the one way propagation time.

#### Tpm—Medium Propagation, Source Node to Destination Node

Since transmissions can occur between any two nodes, the time it takes for a symbol to travel from the source of the transmission to the destination must be known. Use the same propagation constants as above but determine the distance between the source

Token pass				
ITT	15.6	µs		
Tta	12.6		+	Tpt
	28.2	µs	+	Tpt

Token pass and short packet of n data bytes (successfully delivered)				
ITT	15.6	µs		
Tta	12.6		+	Tpt
FBE	15.6			
Tta	12.6		+	Tpm
ACK	6.8			
Tta	12.6		+	Tpm
PAC	37.6		+	4.4n
Tta	12.6		+	Tpm
ACK	6.8			
Tta	12.6		+	Tpm
	145.4	µs		
			+	4.4n
			+	Tpt
			+	4Tpm

Token pass and packet (destination node receiver inhibited)				
ITT	15.6	µs		
Tta	12.6		+	Tpt
FBE	15.6			
Tta	12.6		+	Tpm
NAK	6.8			
Tta	12.6		+	Tpm
	75.8	µs		
			+	Tpt
			+	2Tpm

**Token pass and short packet of n data bytes (broadcast)**

ITT	15.6	$\mu\text{s}$		
Tta	12.6		+	Tpt
PAC	37.6		+	4.4n
Tbd	15.6			
	81.4	$\mu\text{s}$		
			+	4.4n
			+	Tpt

**Token pass and short packet of n data bytes (lost ACK)**

ITT	15.6	$\mu\text{s}$		
Tta	12.6		+	Tpt
FBE	15.6			
Tta	12.6		+	Tpm
ACK	6.8			
Tta	12.6		+	Tpm
PAC	37.6		+	4.4n
Trp	75.6			
Trc	2.0			
	191.0	$\mu\text{s}$		
			+	4.4n
			+	Tpt
				2Tpm

**Token pass and packet (inactive destination)**

ITT	15.6	$\mu\text{s}$		
Tta	12.6		+	Tpt
FBE	15.6			
Trp	75.6			
Trc	2.0			
	121.4	$\mu\text{s}$		
			+	Tpt

**Token pass and packet (no response)**

ITT	15.6	$\mu\text{s}$		
Trp	75.6			
Trc	2.0			
	93.2	$\mu\text{s}$		

node and the destination node. For standard timeouts, Tpm should not exceed  $31\mu\text{s}$ .

**Tpd—Broadcast Delay Time**

Broadcast delay time is the time that elapses from the end of a transmitted broadcast packet until the start of a token pass. At standard timeouts this time is about  $15.6\mu\text{s}$ .

**Trp—Response Timeout**

Response timeout is the maximum time a transmitting node will wait for a response. It is approximately equal to two times the maximum medium propagation delay of  $31\mu\text{s}$  plus the turnaround delay of the ARCNET controller chip. If the response time is exceeded, the transmitting node will assume the destination node is not on the network. The response timeout is about  $75.6\mu\text{s}$  and it scales with extended timeouts.

**Trc—Recovery Time**

This is the time that elapses from the end of a response timeout until the start of a token pass. Trc is about  $2\mu\text{s}$ .

**Tac—Timer Activity Timeout**

The timer activity timeout represents the maximum amount of time that the network can experience no activity. If this time is exceeded, a reconfiguration sequence is initiated. The Tac is approximately  $82.4\mu\text{s}$ .

**Calculating Transaction Times**

With a knowledge of delay constants and the times required to send different ARCNET frames, calculating transaction times for various transmissions is possible. Precise calculations require a knowledge of the propagation delay constant of the cable as well as the distance between any two nodes that are communicating. This could be complex. A more simplified approach would be to approximate the network by modeling it as a star topology with one central hub. All cable segments would be set equal with the network diameter matching that of the network being modeled. This would mean that the two propagation times (Tpt, Tpm) would be equal and would not change as a function of which two nodes were communicating. Using this model the token loop time can be easily calculated.

With the above information, the time it takes to make a complete loop of the network can be calculated. Assume there were eight

## Calculating Token Loop Time

active nodes each connected to a central hub port with 85 meters of coaxial cable. The cable distance between any two nodes would be 170 meters. Therefore, the two propagation delays would be equal. Assume that the hub delay is 320 ns.

$$T_{pt} = T_{pm} = 170(4) + 320 = 1.0\mu\text{s}$$

Each token pass would take 29.2 $\mu\text{s}$ . The total token pass time for all eight nodes would be 233.6 $\mu\text{s}$

Now assume that one node successfully transmits a 100 byte message while all other nodes simply pass the token. The time required to pass the token and complete a short packet (100 byte) transmission would be as follows:

$$\begin{aligned} \text{Token pass and short packet} &= 145.4 + 4.4(100) + T_{pt} + 4T_{pm} \\ &= 145.4 + 440 + 1 + 4 = 590.4\mu\text{s} \end{aligned}$$

Couple this time with seven other token passes (204.4 $\mu\text{s}$ ) yields a token loop time of 794.8 $\mu\text{s}$ .

Other combinations of events can be similarly calculated.

## Extending ARCNET's Distance

### Extended Timeouts

Originally ARCNET was specified to have a four mile (6.7 km) maximum distance limitation which could be achieved with eleven segments of RG-62/u coaxial cable and ten active hubs. The resulting 22,000 feet (6.7km—slightly more than four miles) represented the worst-case distance between two extreme nodes. Actually, the distance constraint has more to do with time delay. With standard timeouts, the round trip propagation delay between any two nodes plus the turnaround time (the time for a particular ARCNET node to start sending a message in response to a received message which is 12.6  $\mu\text{s}$ ) shall not exceed the response timeout of 75.6  $\mu\text{s}$ . This means that the one-way propagation delay shall not exceed 31  $\mu\text{s}$  which is approximately what 22,000 feet (6.7km) of coaxial cable and ten hubs represent. For the vast majority of systems, this is not an issue; however, when considering a fiber optic system a delay budget calculation should be performed to determine if extended timeouts are required.

ET2	ET1	Response Time ( $\mu\text{s}$ )	Idle Time ( $\mu\text{s}$ )	Reconfig Time (ms)
0	0	1209.6	1318.4	1680
0	1	604.8	659.2	1680
1	0	302.4	329.6	1680
1	1	75.6	82.4	840

There are four possible timeouts that can be selected using register bits ET1 and ET2 in the ARCNET controller chip. It must be

remembered that all ARCNET nodes in the network must be set for the same timeout settings. Upon power-up, all ARCNET controllers assume the standard timeout of 75.6  $\mu$ s (ET1=ET2=1). Besides the response time, extended timeouts affect the idle time (the time a node waits before incrementing the next ID counter during a reconfiguration) and the reconfiguration time (the time a node waits before initiating a reconfiguration burst). The accompanying table (based upon a 2.5 Mbps data rate) shows the relationship.

Component	Delay (ns)
Passive hub	10/hub
Active hub	320/hub
RG-62/u cable	4/meter
RG-59/u cable	4/meter
IBM type 3 cable	5.5/meter
Single mode fiber	5/meter
50/125 fiber cable	5/meter
62.5/125 fiber cable	5/meter
100/140 fiber cable	5/meter

### Delay Budget

Every attempt should be made to ensure that the ARCNET system functions with the standard or default timeouts. This would simplify the installation and maintenance of the network since all ARCNET controllers default to the lesser timeout setting upon power-up without any software intervention.

Use the accompanying chart to sum all the delays encountered between the two geographically furthest nodes. Include the delays resulting from both hubs and cables. Notice that the propagation delay for coaxial cable is less than for fiber optic cabling. If the total amount of one-way direction delay for the worst case situation exceeds 31  $\mu$ s, then the timeouts must be extended.

## Software and Standards

### OSI Model

The Open Systems Interconnection (OSI) model describes the various layers of services that may be required in order for two or more nodes to communicate to one another. ARCNET conforms to the physical layer and the medium access control portion of the data link layer as defined by IEEE. All layers above the data link layer collectively are called the protocol stack and the number of services available or used by differing applications vary. The software required to bind a network interface module to a protocol stack is called a driver and many different drivers exist for ARCNET. Drivers require an understanding of the specific ARCNET controllers and should be independent of the protocol above it. The customer has many options.

APPLICATION	
PRESENTATION	
SESSION	
TRANSPORT	
NETWORK	
DATA LINK	Logical Link Control Medium Access Control
PHYSICAL	

APPLICATION	
Data Link — ARCNET	
Physical — ARCNET	

***Collapsed Stack or Null Stack***—The application layer is tied directly to the data link layer. The protocol is provided by the application itself. Customers usually select this proprietary approach when speed of execution is critical and connectivity to other systems is of little interest. A custom driver is written for this implementation. This is a very popular approach for embedded networking.



**Control Link**—SMSC developed IEEE 802.2 services which provide logical link control (LLC) above the MAC sub-layer. This is of interest to some customers.

**NetBIOS**—ATA endorsed session level software adhering to IBM and Microsoft standards. Used with several peer-to-peer network operating systems and, frequently, the interface to ARCNET systems. NetBIOS may also be added on top of TCP/IP and IPX/SPX.

**NetBEUI**—The NetBIOS Extended User Interface is both a NetBIOS interface and protocol. This standard is frequently found in Microsoft networks.

APPLICATION
Transport — TCP
Network — IP
Data Link — ARCNET
Physical — ARCNET

**TCP/IP**—These protocols from the Internet world are becoming increasingly popular. TCP functions as the transport layer and IP functions at the network layer. These protocols provide ARCNET connectivity to the Internet.

APPLICATION
Transport — SPX
Network — IPX
Data Link — ARCNET
Physical — ARCNET

**IPX/SPX**—Internetworking standard developed by Novell and supported by Microsoft derived from the Xerox Network System (XNS). Used with Novell's NetWare. Microsoft's version is called NWLINK.

**NDIS**—Network Driver Interface Specification developed by Microsoft and 3Com. Used with Windows for Workgroups, Windows 95, 98 and Windows NT. This is a driver specification which allows an ARCNET card to bind to either NetBEUI, IPX/SPX or TCP/IP or any other protocol for which an NDIS compatible protocol driver has been written. NDIS 4.0 is a 32-bit driver standard and is used with Windows 95B and NT 4.0

**ODI**—Open Data-link Interface developed by Novell and supported by Microsoft. Used with Novell's NetWare but can operate on Microsoft platforms beginning with Windows for Workgroups 3.11.

When installing ARCNET adapters make sure the proper driver is available from either the adapter supplier or the equipment OEM who specifies the ARCNET adapter.



Contemporary Controls was instrumental in creating the ARCNET Trade Association (ATA)

in 1987. The ATA was formed for the dual purpose of developing working standards for ARCNET and promoting the use of ARCNET as a viable networking technology. The ATA is recognized by the American National Standards Institute (ANSI) as a standards development body and was instrumental in achieving ANSI recognition of the ARCNET standard with ANSI/ATA 878.1 Local Area Network: Token Bus (2.5 Mbps). The ATA has been working on other standards that would simplify the implementation of ARCNET in various industries. The ATA remains as a worldwide clearing house for information regarding ARCNET technology.

### ARCNET Trade Association

The ATA has a standards committee that has developed or is developing ARCNET related standards. Besides endorsing an ARCNET NetBIOS, the ATA is involved with three standards:

- **ANSI/ATA 878.1 Local Area Network: Token Bus (2.5 Mbps)**  
This approved standard defines the basic ARCNET technology, as well as recommending certain practices that increase reliability and interoperability.
- **ATA 878.2 ARCNET Packet Fragmentation Standard**  
This proposed standard addresses the problem of handling data packets that exceed the maximum number of characters that can be sent in one ARCNET transmission. The data packet is fragmented into manageable ARCNET frames that are recombined at the destination node. The standard is based upon RFC 1201.
- **ATA 878.3 Encapsulation Protocol Standard**  
This proposed standard defines a method in which industry standard master/slave protocols can be encapsulated into ARCNET allowing for multimaster operation.

## References

**ARCNET Designer's Handbook**, Document 61610,  
*Datapoint Corporation, 1983*

**ARCNET Cabling Guide**, Document 51087,  
*Datapoint Corporation, 1988*

**ARCNET Factory LAN Primer**,  
*Contemporary Control Systems, Inc., 1987*

**RS-485 Cabling Guidelines for the COM 20020**,  
Technical Note 7-5, Revision E,  
*Standard Microsystems Corporation, May 1994*

**ARCNET's Already Flexible Physical Layer Enhanced with Several EIA-485 Variants**,  
George Thomas, *Fieldcomms USA, June 1997*

**Microsoft Developer Network CD**,  
*Microsoft Corporation, January 1998*

