

CONTROL DATA® BE102 MAGNETIC TAPE TRANSPORT

**THEORY OF OPERATION
DIAGRAMS
WIRE LISTS**

CONTROL DATA
CORPORATION

CUSTOMER ENGINEERING MANUAL

40860800		RECORD of REVISIONS	
REVISION	NOTES		
A	Manual Released. Engineering Change Order 8326 incorporated in original printing.		
(12-1-67)			
B	Manual Reprinted. Publications Change Order 8772 incorporating the following:		
(2-7-68)	Engineering Change Orders 1287, 1312, 1314, 1320 and 1394 affecting pages 1-1, 1-4 thru 1-9, 1-13, 1-21, 1-25, 1-27, 1-29, 1-31 and 1-35.		
	Wire List Section		
	This edition obsoletes all previous editions.		
C	Engineering Change Order PE9071 incorporating the following:		
(5-10-68)	Engineering Change Orders PB1320A, PB1399, PB1423, PB1442, PB1447, PB1465, PB1576, PB1644 and PB1668.		
	Field Change Orders PB1423 and PB1447		
	Circuit Descriptions		
	Theory of Operation		
	This edition obsoletes all previous editions.		
D	This printing incorporates the following Engineering Change Orders:		
(11-1-68)	PB1321, PB1502, PB1565, PB1684, PB1859, PB1861, PB1935, PB5016, PB5048.		
	This edition obsoletes all previous editions.		
E	Engineering Change Order PE13605 revising and reprinting manual to correct errors		
(1-15-70)	included in Revision D. Engineering Change Orders PB5769, PB6069, PB6126, PB5860 are incorporated in this revision.		
	This edition obsoletes all previous editions.		
F	Manual revised incorporating editorial changes and Engineering Change Orders: PB 5240, PB 7104,		
(12-15-70)	PB 7249, PB 7304, PB 7766 affecting pages 4-11, 5-1, 5-2, 5-4 thru 5-13, 5-16 thru 5-19, 5-21, 5-23, 5-25, 5-27, 5-28, 5-29, 5-31, 9-1, 9-2, 9-3, 9-5, 9-7, 9-17, 9-19, 9-21 and 9-25. This edition obsoletes all previous editions.		
G	Manual revised to incorporate the following Engineering Change Orders: PB7920, PB8343,		
(7-4-71)	PB8671, and PB8700 affecting pages; 5-27, 5-31, 5-33, 5-35, 9-17 thru 9-25.		
H	Manual updated to incorporate Engineering Change Order PB8827 affecting page 9-16.		
(10-31-71)			
J	Manual updated to incorporate the following ECO's: PB9432, PB10290, and PB11130 affecting pages		
(10-7-72)	5-17, 9-17 thru 9-20, and deleting page 9-20.1		

FORM CA230 REV. 1-67

Pub No. 40860800
 © 1967, 1968, 1969, 1970
 by Control Data Corporation
 Printed in United States of America

Address comments concerning this manual to:

Control Data Corporation
 Technical Publications
 2621 Van Buren Avenue
 Norristown, Penna. 19401

or use Comment Sheet in the back of this manual.

FOREWORD

This manual has been prepared for customer engineers and other technical personnel directly involved with maintaining and repairing the CONTROL DATA® BE102 Magnetic Tape Transport. The applicable categories of information have been arranged in three separate books as shown below. Refer to the current Control Data Literature Catalog for the publication number and latest revision level for each book.

Section	Title
1	General Description
2	Operation
3	Installation and Checkout
6	Maintenance
4	Theory of Operation
5	Diagrams
9	Wire Lists
8	Parts Data

Information usually contained in Section 7 (Maintenance Aids) has been incorporated into other sections. There is no Section 10 (Equation Summary) for this equipment.

Additional information on the tape transport is found in the following manuals:

Crating Manual, 608 Magnetic Tape Transport

Control Data Power Supplies

Site Preparation and Installation (for appropriate system)

Refer to the Control Data Literature Catalog for publication numbers.

CONTENTS

SECTION 4. THEORY OF OPERATION		Write	5-15
Introduction	4-1	Read Circuits	5-17
Tape Drive Systems	4-1	Density	5-19
Vacuum Columns	4-1	Card Placement	5-21
Reel Drive System	4-2	Operator Panel	5-23
Capstan Drive System	4-5	Tape Deck	5-25
Pneumatic Systems	4-7	Cabling Chart	5-27
Loop Box Blower	4-7	Power Supply 1	5-29
Rotary Pump System	4-7	Power Supply 2	5-31
Cabinet Cooling	4-8	Power Supply 3	5-33
Head Assembly	4-10	Power Panel and Pneumatic Package	5-35
Power Supply	4-11	Power and Manual MC Sequence	5-36
SECTION 5. DIAGRAMS		End of Tape Marker Detection	5-36
Key to Logic	5-1	Rewind Operation	5-37
Symbol Index	5-1	Load Operation Flow Chart	5-38
Block Diagram	5-3	SECTION 9. WIRE LISTS	
Search Load Point and Fault	5-5	Description of Wire Lists	9-i
Load Point, End of Tape, Ready	5-7	Logic Chassis	9-1
Motion	5-9	Main Harness Assembly	9-17
Rewind and Unload	5-11	Power Supply Harness	9-21
Write Enable and Select	5-13	DC Panel Harness	9-27

FIGURES

4-1	Tape Path	4-2	4-4	Rotary Pump Pneumatic System	4-8
4-2	Vacuum Column Sensors	4-4	4-5	Cooling Air System	4-9
4-3	Capstan Belt Drive System	4-5	4-6	Simplified Power Distribution	4-12

TABLES

5-1	Communication Lines	5-2
-----	---------------------	-----

SECTION 4

THEORY OF OPERATION



SECTION 4

THEORY OF OPERATION

INTRODUCTION

The functional parts of the tape transport are the tape drive systems (vacuum columns, reel drive, and capstan drive), pneumatic systems (loop box and rotary pump), head assembly, cabinet cooling system, and power supply assembly.

TAPE DRIVE SYSTEMS

VACUUM COLUMNS

The vacuum columns (Figure 4-1) buffer tape and provide tape tension for maintaining tape-to-head contact and proper tape wind onto the reels. The tape loop is formed in the vacuum column by the application of vacuum under the tape and the presence of atmospheric pressure above the tape. The tape loops separate the heavy tape reels from the strip of tape directly under the head assembly. This arrangement buffers the heavy reels from the capstan drive system so that only the small mass of tape in the vacuum column need be moved. The small mass of tape is moved at a steady speed and is started or stopped rapidly. Tape is accelerated to high speed or decelerated to a complete stop within 3 milliseconds. During a forward operation, the forward capstan pulls tape from the reverse column and places it into the forward column. As tape is pulled from the reverse column, it is replaced by tape from the reverse reel above that column. As tape is placed into the forward column, slack in the tape loop is taken up by the forward reel above that column.

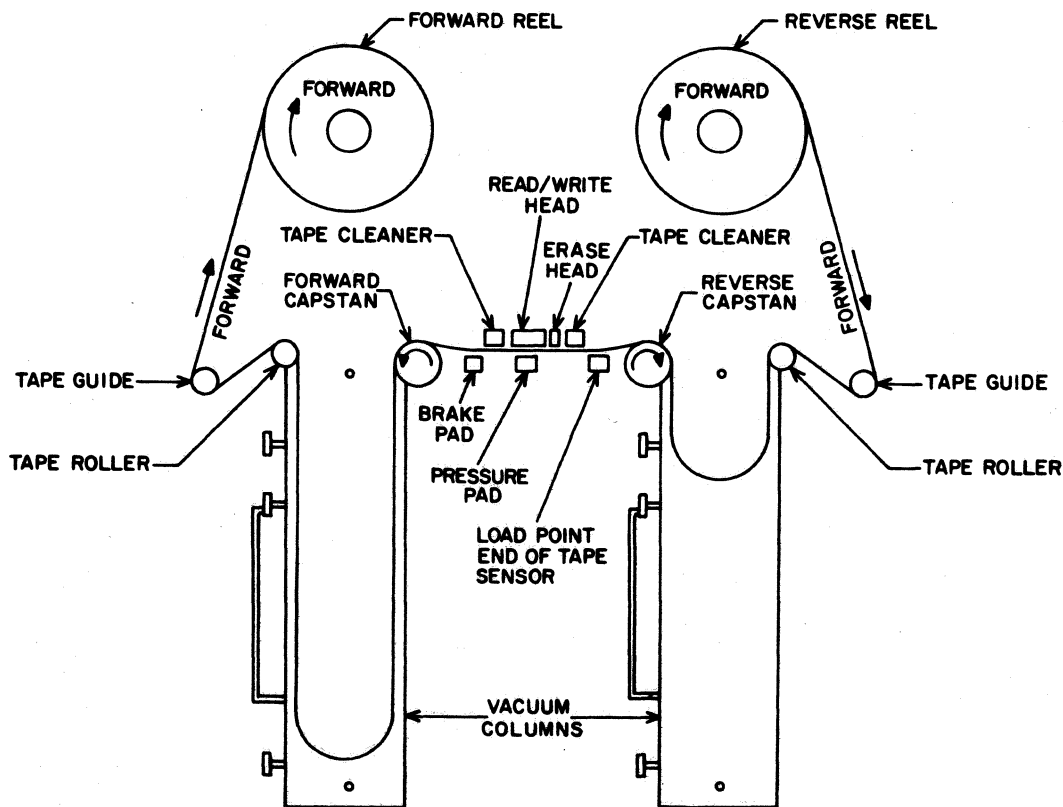

3N14

Figure 4-1. Tape Path

REEL DRIVE SYSTEM

The reel drive system removes or replaces tape in the vacuum columns as the tape is moved past the read/write heads by the capstan drive system. Identical Forward and Reverse Reel Servo circuits control the amount of tape in the vacuum columns. Each servo circuit contains a 115-vdc reel motor, reel motor brake, reel drive circuit board in the power supply, and three vacuum/pressure sensors in each vacuum column.

The reel motor is mounted on the rear of the tape deck. The reel hub on the front of the tape deck is attached to the front shaft of the reel motor. The armature of the reel motor brake is attached to the rear shaft of the reel motor and rotates with the shaft. The reel motor brake coil is fixed to the reel motor housing. To stop the reel motor, current is passed through the brake coil (motor current is off). The current through the brake coil produces a magnetic flux which attracts the brake armature to the brake

coil face. The stationary brake face contains a friction material that contacts the rotating brake armature to stop the motor shaft.

Tape position in the vacuum columns is monitored by differential pneumatic sensors (Figure 4-2). The outputs of the sensors control the reel drive motors to correctly position tape in the columns. Both columns function identically.

The sensor switch contacts are closed when there is a difference in pressure between the two ports connected to each switch. The first switch to be activated during a Load Tape operation is the Fault Differential switch. Before the tape loop is drawn past the top fault port, the vacuum sensed by the top and bottom ports is equal. This is a faulted condition which must be bypassed by the logic during the tape loading operation. As soon as the tape goes below the top fault port, this port again senses atmospheric pressure. There is now a pressure differential between the top and bottom hemispheres of the switch: pressure at the top, vacuum at the bottom. The pressure difference causes the diaphragm inside the switch to be pulled down, closing the switch contacts. The ground signal returned to the logic then indicates a Not Fault condition.

If tape moves below the bottom fault port or above the top fault port in either vacuum column, the pressure differential is destroyed. The diaphragm returns to the neutral position and opens the switch contacts. This is a Fault condition and results in the reel motors being de-energized.

The other sensors in the vacuum column detect the position of the tape loop. Their outputs are used to correctly position the tape in the columns. The servo circuit causes the reel motor to pull tape out of the column, dump it into the column, or brake according to signals supplied by the sensors. The servo drive reaction caused by various loop positions is shown in Figure 4-2.

During a Forward Tape Motion operation, the capstans are continuously pulling tape out of the reverse column and dumping it into the forward column. The reel drive servos keep the tape correctly positioned. During a high-speed rewind, however, the tape loops are positioned by interaction between the Capstan Drive circuit and the Reel Drive circuit. The reel motor brakes are disabled. The capstan drive system controls the rate that tape is dumped into the reverse column. As long as tape is above the bottom reverse sensor, the Capstan Drive circuit applies vacuum to the capstan to

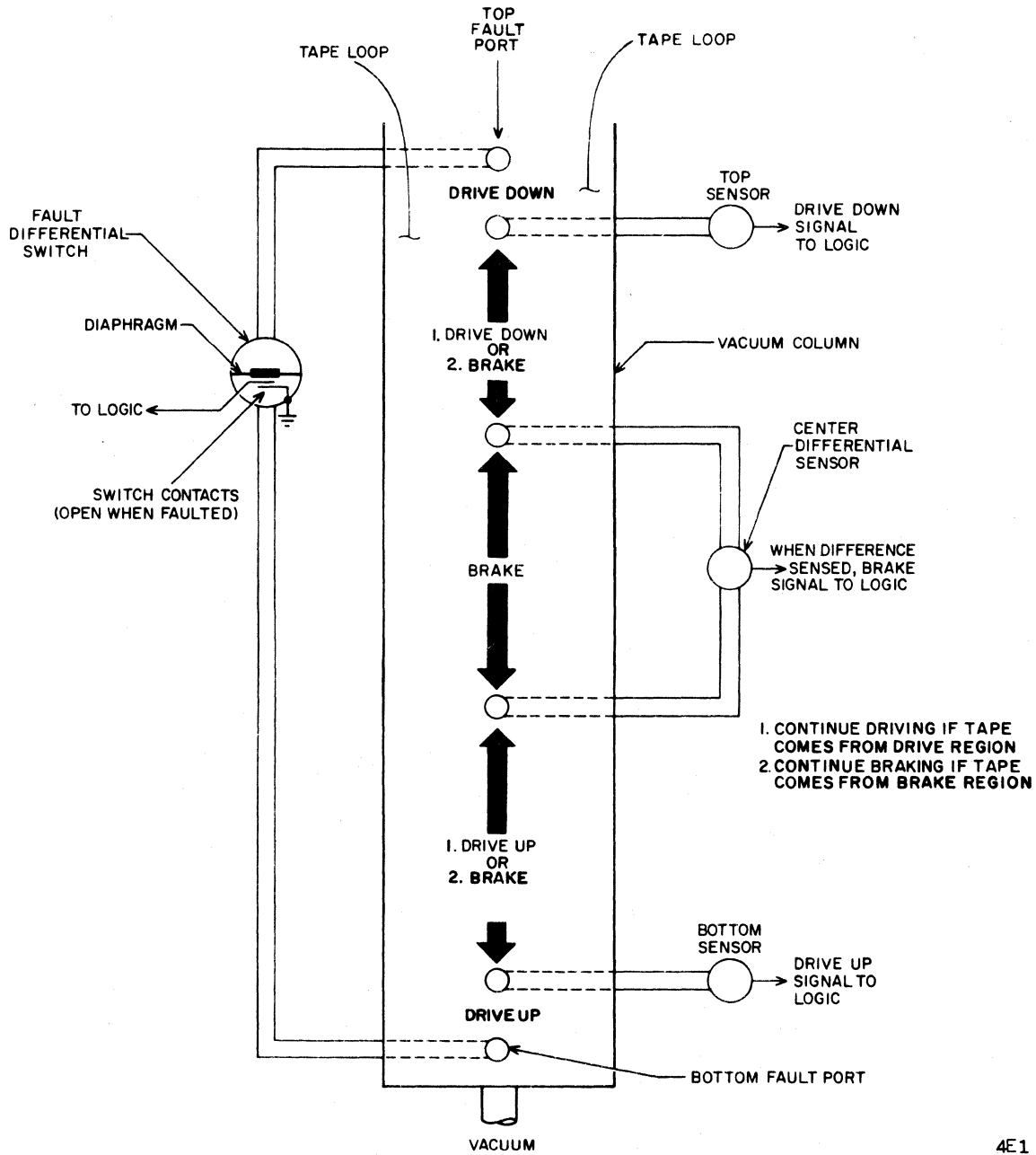

4E1

Figure 4-2. Vacuum Column Sensors

drive tape into the reverse column. At the same time, the reel motor is off. As soon as tape goes below the bottom reverse sensor, vacuum is turned off and the reel motor is turned on to pull tape out of the column. Therefore, the interaction of the Capstan Drive circuit and Reel Drive circuit results in an alternate series of pulsations about the sensor: tape drive to push the tape below the sensor, reel drive to pull it above the sensor. The same type of positioning simultaneously takes place about the upper forward sensor.

CAPSTAN DRIVE SYSTEM

The capstan drive system contains two capstans, two commutators, and a tape brake mounted behind the guide plate on the front of the tape deck. Also included in this system are two capstan valves, a brake valve, and a capstan belt drive system mounted on the rear of the tape deck. The capstan belt drive system is shown in Figure 4-3.

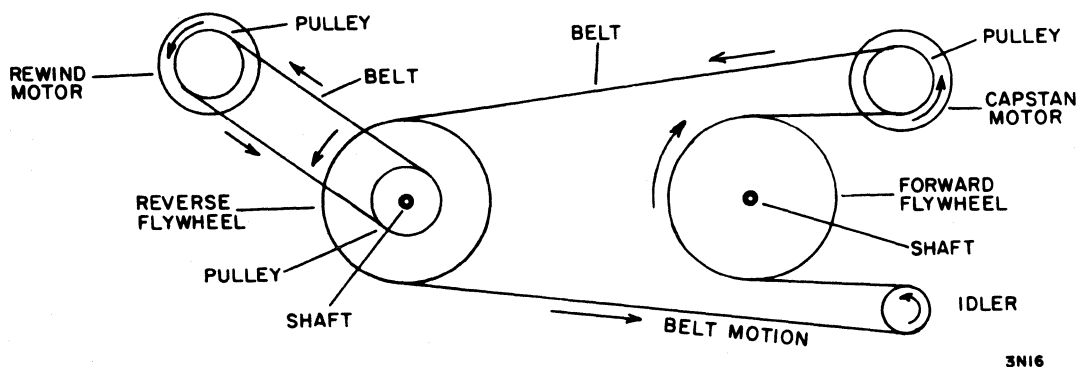

Figure 4-3. Capstan Belt Drive System

The capstan motor is used for normal forward and reverse operation. The rewind motor is used for high-speed reverse operation. The capstans are connected to the flywheel shafts and rotate in opposite directions due to the belt arrangement shown in Figure 4-3. The reverse capstan wheel rotates clockwise; the forward capstan rotates counterclockwise.

During normal operation, a clutch bearing in the reverse capstan flywheel grips the capstan shaft and the flywheel rotates the capstan. During high-speed rewind, the

higher speed of the rewind motor belt causes the reverse flywheel clutch bearing to slip so that only the pulley drives the reverse capstan.

Even though the capstan motor runs during a Rewind operation, it has no effect in rotating the reverse capstan. Fast acceleration and recovery are possible during rewind because the rewind motor does not have to rotate the heavy flywheel.

Pressure and vacuum to the capstans and brake are supplied by the manifold and controlled by pneumatic valve assemblies mounted on the rear of the tape deck. Only the vacuum line from the manifold is connected to the brake valve.

Each capstan valve assembly contains a permanent magnet, a valve nozzle, and a voice coil. The direction of current through the voice coil controls whether pressure or vacuum is gated to the capstan. With current flow in one direction, the magnetic poles of the permanent magnet and the voice coil repel the voice coil outward; the voice coil is attracted inward with current flow in the opposite direction.

The capstan wheels are hollow and fluted with a hole drilled in each groove. This permits either pressure or vacuum to be applied to the tape to repel or attract it against the capstan. In the center of each of the capstan wheels is the commutator block. The commutator block receives high vacuum or pressure from the rotary pump pneumatic system via the manifold and the capstan valves. A slot in the block routes the vacuum or pressure to the outside one-quarter of the capstan wheel. The flow of vacuum or pressure to the commutator block is controlled by the capstan valves. The capstan valves are controlled by commands from the Capstan Drive Logic circuits.

To drive tape, one of the capstans receives vacuum, drawing tape to it, while the other capstan receives air pressure to float the tape over it. To move tape forward, the forward capstan receives vacuum and tape is pulled across the heads. Reverse tape motion requires that the reverse capstan receive vacuum while the forward capstan receives pressure.

During a normal forward or reverse operation, the pneumatic brake port has no vacuum applied to it. When a motion command is terminated, the brake valve is energized and the brake port receives high vacuum. At the same time, pressure is valved to both capstan wheels. The tape is drawn to the brake port and floated over the capstan wheels. Tape motion is quickly and smoothly stopped.

PNEUMATIC SYSTEMS

The transport contains two physically and functionally separate pneumatic subsystems: the loop box blower system and the rotary pump system. The loop box blower provides the high volume of low vacuum necessary for the vacuum columns (loop boxes) and the tape scrapers. The rotary pump system provides the relatively low volume of high pressure and vacuum necessary to operate the tape brake and capstans.

LOOP BOX BLOWER

The loop box blower system consists of a blower, plenum chamber and connection hose, and the loop box vacuum columns. The blower draws air out of the vacuum columns. A vacuum gage mounted on the plenum chamber indicates the vacuum present in the system at any time.

ROTARY PUMP SYSTEM

The rotary pump system (Figure 4-4) consists of a rotary carbon vane pressure/vacuum pump and pump-drive motor, a pressure cooling coil, associated filters, gages, and relief valves, and the manifold.

The rotary carbon vane pump consists of two separate pump assemblies within a common exterior housing. The common axis shaft is belt-coupled to a drive motor which serves both units. The central rotor is bearing mounted and located off-center toward the top of the housing. Four carbon vanes ride freely in slots in the cylindrical rotor. When the rotor turns, centrifugal force causes the vanes to move out and follow the inner surface of the housing.

The dual pump forms two independent pneumatic circuits: one pressure, the other vacuum. The pressure pump draws atmospheric air through an intake muffler which limits operating sound and filters all dust and foreign particles from the incoming air. The pressurized air is passed to the cooling coil which absorbs any heat generated as a result of high compression. After cooling, the air is routed to the pressure chamber of the manifold. The manifold serves as a reservoir to eliminate pulsation that might

appear in the system. A second filtering process also takes place in the manifold. Pressure and vacuum in the manifold may be observed by gages and regulated by the manifold relief valves.

The vacuum circuit functions in a similar manner except that high vacuum is pulled on the circuit and pump exhaust is through an exhaust muffler. The vacuum circuit does not need a cooling coil.

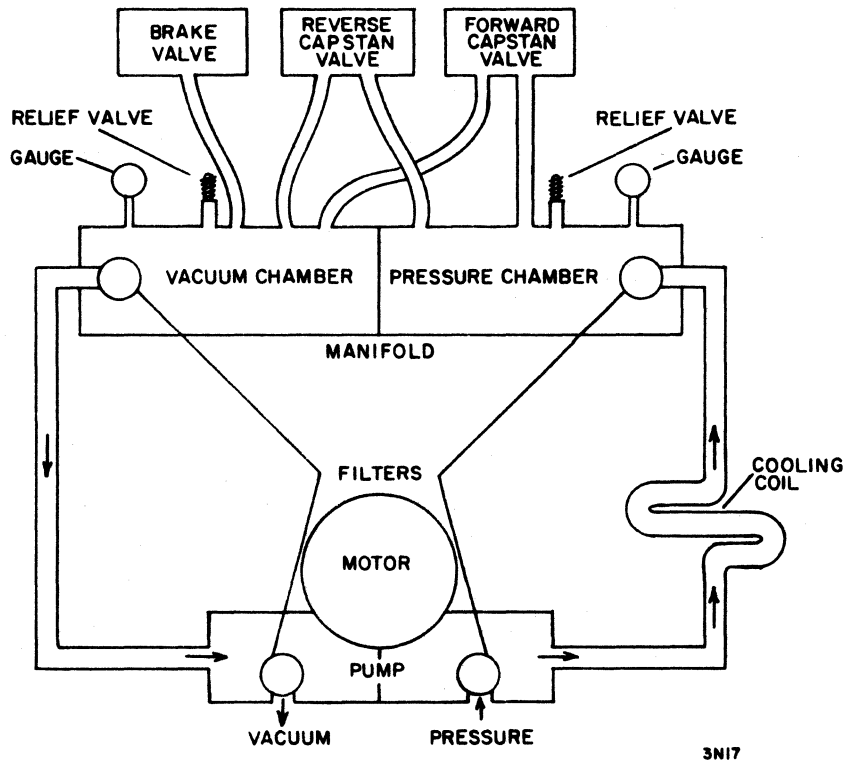

Figure 4-4. Rotary Pump Pneumatic System

CABINET COOLING SYSTEM

The cabinet cooling system (Figure 4-5) has three functions. First, it provides cooling air (directly through tubing, or by general circulation) to aid in transport heat dissipation. Second, it provides a slight internal pressure inside the transport cabinet to prevent contaminants from entering the transport. And third, it pressurizes the tape

deck to prevent contaminants from being deposited on the tape and to aid in a Load Tape operation.

The cooling motor and blower assembly is mounted at the bottom of the transport cabinet as part of the pneumatic package assembly. Cooling air is drawn through a filter in the bottom of the cabinet. The filter is removable for replacement or cleaning. The assembly should require no other maintenance. A circuit breaker on the power supply front panel prevents motor overloads. When the circuit breaker is on and power is applied to the transport, the cooling motor will be on.

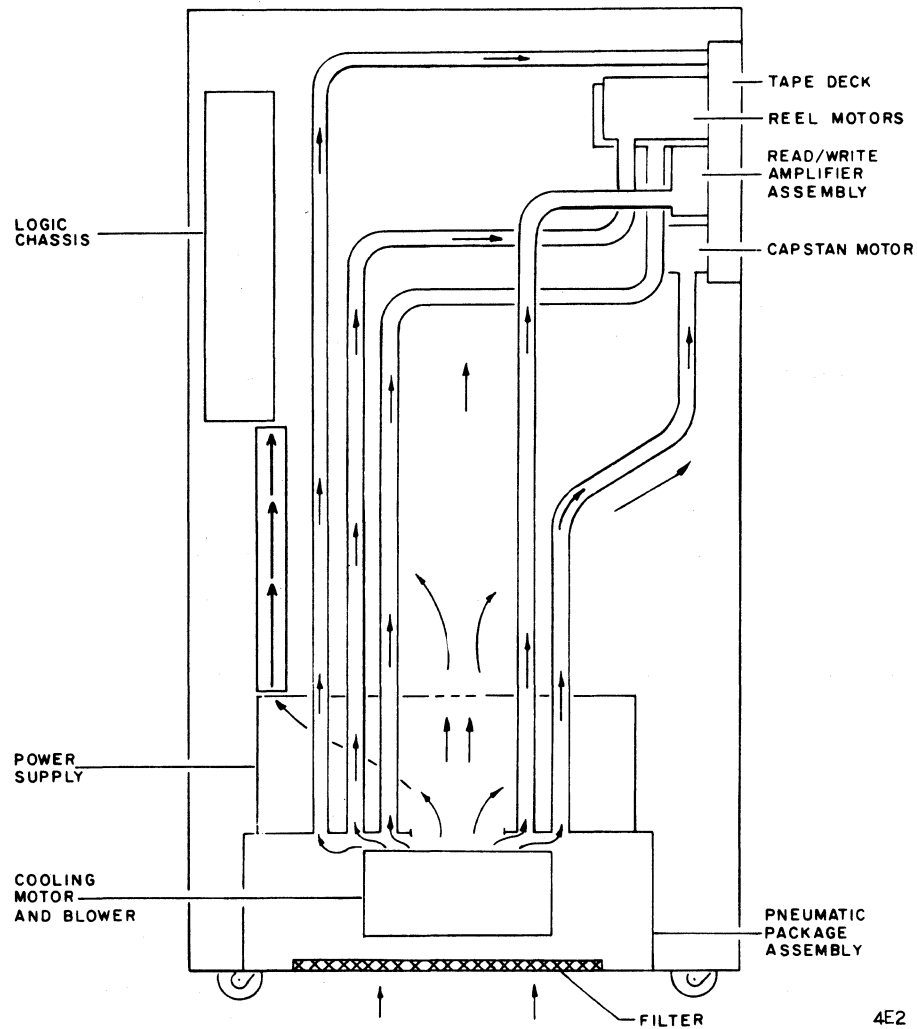

Figure 4-5. Cooling Air System

HEAD ASSEMBLY

The head assembly consists of a read/write head, erase head, and two tape cleaners. Associated with the head assembly are the preamp cards and write driver cards located in a chassis behind the tape deck and the cables which carry the signals between the preamplifiers and the logic chassis.

The head assembly contains seven write heads and seven read heads mounted side by side in such a way that tape passes first under the write heads and then under the read heads. This allows any errors in each line of recorded data to be immediately detected by the read heads. The width of each write head is slightly wider than the corresponding read head for that track. This ensures that the read head will be within the track written by the write head.

Each read or write head consists of an individual wire-wound core. As current flows through the windings in a write head, a magnetic field is induced across the write gap at the bottom of the head. As tape passes under the write head, the magnetic particles on the tape are aligned by the lines of flux across the write gap. When current flow through the coil windings reverses, the magnetic particles on the tape are realigned in the opposite direction.

As the tape passes under the read head, the direction in which the magnetic particles on the tape are aligned is sensed by the read head. This signal is amplified by the preamplifiers, then transmitted to the logic chassis for processing.

The erase head has a steady dc current through it during a Write operation. This aligns all particles on the tape in the same direction before the tape passes under the write head. Therefore, all information is erased from the tape before new information is written. During a Read operation, the erase head is turned off so prerecorded information is not lost.

The tape cleaner contacts the tape and removes all foreign particles from the tape before recording. The scraper blades dislodge any foreign material on the tape. The particles are then removed from the head area by vacuum.

The read/write surfaces are deflexed 5 degrees below the level of the top of the capstans. This holds the tape firmly against the recording surfaces of the head. The shield block assembly shields the read heads from the write heads.

POWER SUPPLY

The power supply operates from a 208-volt, 3-phase, 60-hertz, wye-connected power source. The power supply circuits are protected by circuit breakers that are accessible on the front panel of the power supply. Power is distributed within the power supply and to tape transport components by means of relay switching action. The following descriptions apply when the circuit breakers are turned on.

When the POWER switch on the operator control panel is pressed, a ground path is provided for the rectified output of transformer T3, and relay K2 is energized. Operating power is then routed through closed contacts of relay K2 to the cooling motor. The cooling blower immediately circulates cooling air throughout the tape transport. Power is also routed through the closed contacts of relay K2 to the dc power panel. Resistor R3 limits power surges during initial operation. The dc power supply outputs of +20/-20 are routed within the power supply and to tape transport components as shown in Figure 4-6. Relay K30 is immediately energized by +20 vdc from the dc power panel and ground through a closed contact of relay K2. When the POWER switch is released, relay K2 is held energized by ground through a closed contact of relay K30. Another closed contact of relay K30 allows resistor R3 to be bypassed so that full power can be applied to the dc power panel. Capacitor C30 holds ground on the line for approximately 2 seconds after relay K2 energizes to allow a Master Clear of the logic circuits. When the POWER switch on the operator control panel is pressed, ground is removed from relays K2 and K30 and power is dropped. The POWER switch has one section of momentary contacts that are closed only when the switch is held depressed and one section of alternate contacts that hold power on.

Pressing the LOAD switch on the operator panel causes Load relay K1 to be energized by -20 vdc through a transistor. Operating power is routed through TRX61, TRX62, and TRX63 to the rotary pump motor, capstan motor, loop box vacuum motor, hour meter, and the SCR circuits in the reel drive boards.

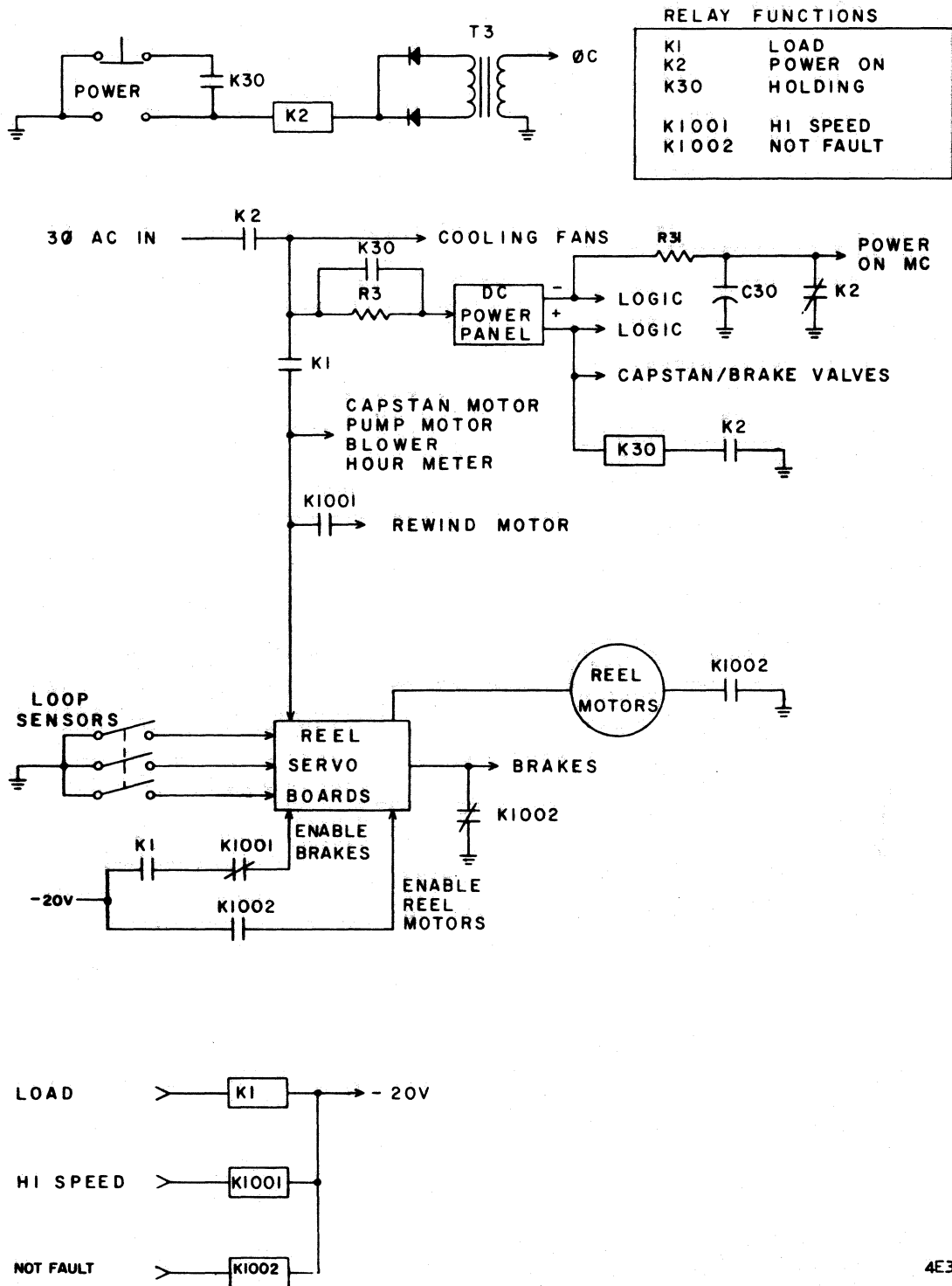

Figure 4-6. Simplified Power Distribution

Not Fault relay K1002 is energized as tape is loaded. This permits -20 vdc power to enable the reel motors and brakes to complete the loading process. At the same time, the loop box sensors are also activated so the reel motors can position the tape in the vacuum columns. The dc input and ground inputs from the loop box sensors control either of two relays in the reel servo boards. Depending upon which relay is energized, a particular SCR signal is routed through the closed contacts of the relay to the reel motor. One SCR signal causes the reel motor to turn clockwise, the other, which is of opposite polarity, drives the motor counterclockwise. If the center loop box sensor senses that tape is correctly positioned in the vacuum columns, its closing disables the reel motors by removing the dc power from the reel servo board relays. This sensor also turns on a transistor in the board which applies the reel brakes.

If a fault condition occurs, ground is removed from relay K1002 and the relay de-energizes. The opened contacts of K1002 remove -20 vdc from the reel servo board relays to disable the motors. At the same time, another set of K1002 contacts closes to ground the reel brakes inputs to turn on the brakes.

When the REWIND switch on the operator control panel is pressed, Hi Speed relay K1001 sets. An open contact of the relay removes the brake voltage from the reel servo boards to disable the brakes. Another set of K1001 contacts close, applying ac power to the rewind motor.

SECTION 5

DIAGRAMS



Logic diagrams represent a symbolic approach to electronic schematics. By using symbols to represent building block circuits, the diagram becomes easy to read if the reader understands the function of the symbols. In Control Data Corporation logic, two signals, a logical 0 ("0") and logical 1 ("1"), are the possible input or output conditions of a circuit. A circuit with an output of "1" is "up" and a circuit with an output of "0" is "down". Detailed descriptions of logic symbols and their associated building block circuit cards are contained in the appropriate printed circuit manual (1604 and 3600 Card Types). Refer to the Literature Distribution Center Catalog for the publication number and latest revision level.

STANDARD LOGIC SYMBOLS

Standard logic diagram symbols for Control Data equipment using 1604- or 3600-type cards are inverters, flip-flops, control delays, capacitive delays, inductive delays, and line drivers and receivers.

Inverters

An inverter is a logic element which provides an output that is an inversion of its input. When more than one input is provided to an inverter, "1's" take precedence over "0's" and drive the output of the inverter to "0". Because any "1" input of several inputs drives the output to a "0" an inverter may be considered an inverting OR (NOR) gate when more than one input is present.

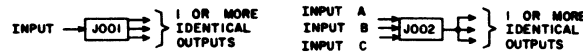

Figure 1. Inverter Symbols

Acceptable conventions for showing multiple OR inputs are given in Figure 2.



Figure 2. OR Circuit Conventions

An AND gate requires that all its inputs be "1's" in order that its output be a "1". If one or more of the inputs to an AND gate are "0" the output is a "0". Figure 3 illustrates conventions for showing AND gates feeding an inverter.



Figure 3. AND Circuit Conventions

Figure 4 illustrates a combination AND/OR input.

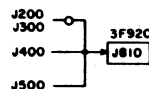

Figure 4. AND/OR Circuit Convention

KEY TO LOGIC SYMBOLS

(STANDARD 1604 OR 3600 CARD TYPES).

Flip-Flops (FF)

The flip-flop (FF) is a storage device with two stable states - designated as Set and Clear - and is composed of two or more inverters. The logic symbols (Figure 5) are formed by the combination of inverter symbols. By convention, Set inputs and outputs are shown in the upper part of the symbol and Clear inputs and outputs are shown in the lower part of the symbol.

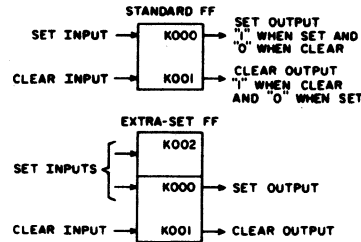

Figure 5. Flip-Flop Symbols

Figure 6 illustrates the interconnection of inverter symbols to form a flip-flop symbol. The term numbers assigned to each flip-flop are the term numbers of the internal inverters as seen by comparing the terms in Figure 5 with those in Figure 6. Notice that the Set output is the output of inverter K001, and the Clear output is the output of inverters K000 and K002.

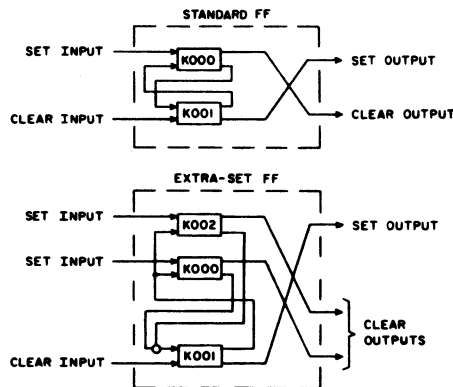

Figure 6. Internal Inverter Connections for a Flip-Flop

Control Delay

A control delay is a timing device consisting of an H term which receives the input and one or more V, Y, or N terms to provide the outputs. The H term is essentially a flip-flop with controlled feedback and occupies an entire printed circuit card. The output term(s) are inverter(s) located elsewhere on the logic chassis. The "1" outputs from a control delay are clocked pulses which are delayed one phase time from the "1" inputs. Clock inputs are not shown on the logic diagrams for any H, V, Y, or N terms; these terms, which control the start and duration of the delayed output pulses, may be found in the Equation Summary. Figure 7 illustrates two representative forms of the control delay symbol, with possible inputs and outputs labelled. Figure 8 shows the electrical connections for the two forms.

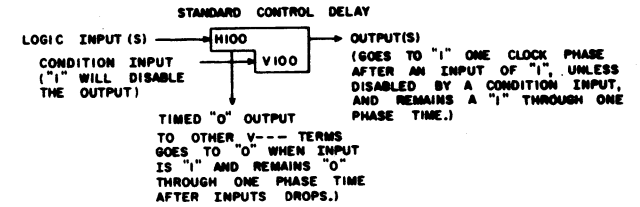

Figure 7. Control Delay Symbols

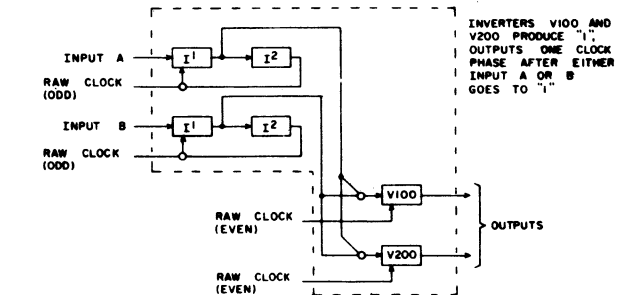
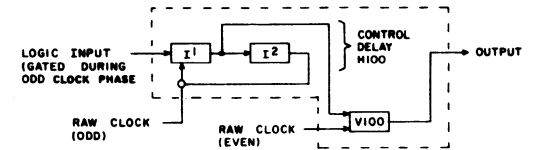

Figure 8. Electrical Connections for Control Delay

Control delays may have multiple inputs and/or multiple outputs. When a control delay has multiple output terms (i.e., more than one V, Y, or N term), each output term may have a separate conditioning input.

Capacitive Delays

A capacitive delay is used to delay the "1" input to a logic element. ("0" inputs are not affected by the delay.) Capacitive delays may be active or passive, depending upon whether or not transistors are used as part of the delaying circuit. Delay periods are checked by using a dual-trace scope connected to the input and output of the delay producing circuit. The actual connection points for the scope and probes vary for different cards and should be determined by referring to the Printed Circuit Manual.

Active delays may be recognized by the circuit letter always present as part of the card location. Pin numbers are also shown when external wiring is needed to connect the proper capacitance. In Figure 9, the pluggable delay uses this wiring to connect to capacitors on the same card. In the third example, this wiring connects to capacitors located on two separate capacitor cards.

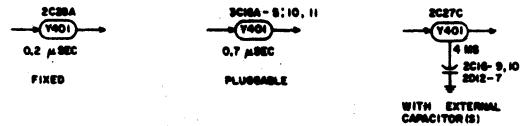

Figure 9. Active Capacitive Delays

All passive capacitive delays (Figure 10) are formed by wiring grounded capacitors, located on one or more capacitor cards, as an AND input to the affected logic element. For this reason, all passive delays show pin numbers to provide this external wiring data.



Figure 10. Passive Capacitive Delays

Capacitive delays may be adjustable or nonadjustable, depending on the card type and/or the external wiring connections on the card. When it is necessary to adjust the delay period in order to obtain specified circuit operation (usually done by varying a potentiometer in the RC network), a diagonal arrow is added to the delay symbol as shown in Figure 11.



Figure 11. Adjustable Capacitive Delays

Inductive Delays

An inductive delay is used to delay either the "1" or "0" input to a logic element or as a tapped delay line for timing of operations. The symbol for this delay is an elongated oval with a double vertical line just within the input end of the oval. When used as a tapped delay line, the inductive delay is terminated in its characteristic impedance. Inductive delays are identified

in the same manner as capacitive delays (except for the vertical lines) unless they are used as delay lines. On multi-section cards where no identifying circuit letters are present, pin numbers are shown adjacent to the input and output arrows. Figure 12 shows both kinds of inductive delays.

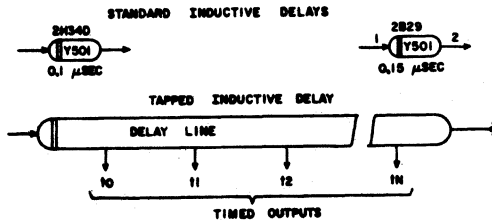

Figure 12. Inductive Delays

Line Drivers/Receivers

Voltage levels used to represent "1's" and "0's" on cables are different from those used for internal logic. The level shift to and from internal logic is made by line drivers and line receivers. These cards may be considered as inverting the signal electrically, but not logically. The letters commonly associated with these cards are L & M (1804) and R & T (3000 Series). A 3000 Series Receiver may also be used to perform a logical inversion by swapping the twisted pair wires. This usage is indicated by a circle on the input side of the symbol. In Figure 13, "1's" and "0's" have been added to clarify the logic states; they are not part of the symbol.

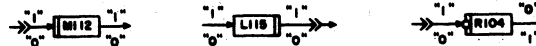

Figure 13. Typical Line Driver/Receiver Symbols

NON-LOGIC CONVENTION

The use of the double vertical bar, as shown in Figure 13, denotes a shift in signal voltage level from that used in internal logic. The double bar appears on the input or output side of the symbol, depending on which side connects to the non-logic-level signal. No particular voltage level is implied by the double bar - only that it is non-logic.

JACK ASSIGNMENTS

Each numbered term in the logic diagrams contains a jack assignment showing the physical location of that hardware element and the test point (circuit section) associated with it. For some card types, the test point letter is replaced by a pin number. For these cases, a card extender must be used in order to test that section of the card. Also, some symbols show no test point. This is because the entire card is used for one purpose (e.g. a single inverter, FF, or control delay). Figure 14 illustrates the inverter J001, with 2D12A representing its jack assignment.

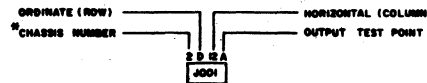

*When most or all jack assignments are located on one chassis, the chassis numbers for that chassis are omitted. All multi-chassis devices include a chassis number as part of each jack assignment.

Figure 14. Jack Assignment Scheme

CABLE IDENTIFICATION

Cable connections are represented by the MIL-STD-15 symbol and identified as to connector location and pins used, as shown in Figure 15.

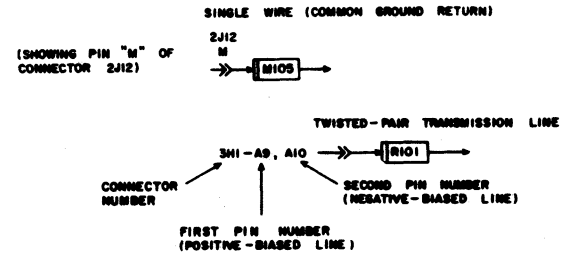

Figure 15. Cable Connections

SPECIAL LOGIC SYMBOLS

Nonstandard elements (special logic and/or non-logic elements) are represented by a special circuit symbol (generally a rectangle as shown in Figure 16). The special circuit symbol always shows the symbol designation, jack location, and the card type. Supplemental information may also be shown such as in the case of special delay cards which indicate the delay period. For detailed information refer to the specific card type in the appropriate Printed Circuit or Logic Module Manual.

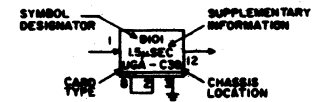

Figure 16. Symbol for Special Circuits

INPUT/OUTPUT DESIGNATIONS

Where several pages of logic are involved, a symbol index and term list (side cars) are incorporated within the manual. Also in certain instances such as special card types or on equipments for which no equation summary exists (as for peripheral devices) input and output pin numbers are indicated on each logic element as are the output destinations of the elements (Figure 17).

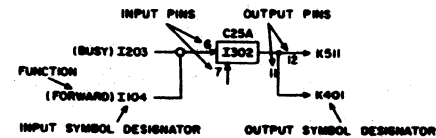

Figure 17. Input/Output Designations

SYMBOL INDEX

The Symbol Index is an alphanumeric listing of every logic symbol, along with the page number of the diagram on which that term is shown. In certain instances a term may be shown on more than one diagram. In these cases, an asterisk (*) immediately follows the additional symbols in the index.

D020	1-27
D021	1-27
D021*	1-29
D022	1-27
D022*	1-29
D023	1-27
D023*	1-29
D024	1-19
D025	1-19
E000	1-31
E001	1-31
E002	1-31

Typical Symbol Index

TERM LIST

An individual Term List is associated with each logic page. The list indicates all inputs (and in the case of peripheral devices, outputs) which are associated with that particular page of logic, but which do not originate on that page. The term list indicates the logic symbol, the chassis location of the symbol, and the diagram page on which that term is shown.

TERM	LOCATION	PAGE
A113	1J36R	1-03
A114	1J35A	1-03
A115	1J35B	1-03
J025	1E42A	1-15
J026	1E37A	1-15
J030	1E36B	1-15
J043	1B32A	1-17
J053	1D16A	1-19
J084	1F30R	1-25
J120	1D27A	1-21

Individual Term List



SYMBOL INDEX

D000	1-13	I114	1-11	K000	1-15	L100	1-7	Y001	1-13	Y514	1-17
D001	1-13	I115	1-11	K001	1-15	L101	1-7	Y002	1-13	Y520	1-17
D100	1-11	I116	1-7	K010	1-15	L102	1-7	Y003	1-13	Y521	1-17
D101	1-11	I117	1-7	K011	1-15	L200	1-19	Y010	1-15	Y522	1-17
D102	1-11	I118	1-7	K020	1-15	L210	1-19	Y020	1-15	Y523	1-17
D103	1-11	I119	1-7	K021	1-15	L220	1-19	Y030	1-15	Y524	1-17
D104	1-5	I120	1-7	K030	1-15	L400	1-9	Y040	1-15	Y530	1-17
D105	1-5	I121	1-7	K031	1-15	L500	1-17	Y050	1-15	Y531	1-17
D106	1-5	I122	1-11	K040	1-15	L501	1-17	Y080	1-15	Y532	1-17
D107	1-5	I125	1-7	K041	1-15	M000	1-15	Y100	1-5	Y533	1-17
D109	1-7	I126	1-5	K050	1-15	M010	1-15	Y101	1-5	Y534	1-17
D110	1-7	I127	1-7	K051	1-15	M020	1-15	Y102	1-5	Y540	1-17
D200	1-19	I201	1-19	K080	1-15	M030	1-15	Y103	1-11	Y541	1-17
D201	1-19	I211	1-19	K081	1-15	M040	1-15	Y104	1-11	Y542	1-17
D202	1-19	I220	1-19	K090	1-13	M050	1-15	Y105	1-11	Y543	1-17
D203	1-19	I221	1-19	K091	1-13	M080	1-15	Y106	1-7	Y544	1-17
D400	1-9	I301	1-13	K100	1-5	M090	1-15	Y107	1-7	Y550	1-17
D401	1-9	I302	1-13	K101	1-5	M091	1-13	Y108	1-7	Y551	1-17
I000	1-15	I304	1-13	K102	1-5	M092	1-13	Y109	1-7	Y552	1-17
I010	1-15	I305	1-13	K103	1-5	M093	1-13	Y110	1-7	Y553	1-17
I020	1-15	I306	1-13	K104	1-5	M100	1-5	Y111	1-7	Y554	1-17
I030	1-15	I307	1-13	K105	1-5	M101	1-5	Y112	1-5	Y580	1-17
I040	1-15	I310	1-13	K106	1-11	M102	1-5	Y113	1-11	Y581	1-17
I050	1-15	I311	1-13	K107	1-11	M103	1-5	Y114	1-11	Y582	1-17
I080	1-15	I400	1-9	K108	1-11	M104	1-5	Y200	1-19	Y583	1-17
I090	1-15	I401	1-9	K109	1-11	M105	1-5	Y210	1-19	Y584	1-17
I091	1-15	I402	1-9	K110	1-11	M106	1-5	Y220	1-19		
I092	1-15	I403	1-9	K111	1-11	M107	1-5	Y400	1-9		
I094	1-15	I404	1-9	K112	1-7	M108	1-11	Y401	1-9		
I095	1-15	I405	1-9	K113	1-7	M109	1-11	Y402	1-9		
I096	1-13	I406	1-9	K114	1-5	M110	1-11	Y403	1-9		
I097	1-13	I407	1-9	K115	1-5	M111	1-7	Y404	1-9		
I100	1-5	I408	1-9	K116	1-7	M200	1-19	Y406	1-9		
I101	1-5	I409	1-9	K117	1-7	M201	1-19	Y407	1-9		
I104	1-5	I410	1-9	K200	1-19	M210	1-19	Y500	1-17		
I105	1-5	I411	1-9	K201	1-19	M211	1-19	Y501	1-17		
I106	1-5	I412	1-9	K210	1-19	M230	1-19	Y502	1-17		
I107	1-5	I413	1-9	K211	1-19	M300	1-13	Y503	1-17		
I108	1-5	I414	1-9	K400	1-9	M400	1-9	Y504	1-17		
I110	1-5	I415	1-9	K401	1-9	M401	1-9	Y510	1-17		
I111	1-5	I416	1-9	K402	1-9	M402	1-9	Y511	1-17		
I112	1-5	I417	1-9	K403	1-9	M403	1-9	Y512	1-17		
I113	1-5	I418	1-9	L000	1-13	M404	1-9	Y513	1-17		
		I419	1-9			Y000	1-15				

TABLE 5-1. COMMUNICATION LINES

TRANSPORT TO CONTROLLER	CONNECTOR/PIN	SIGNAL FUNCTION	CONTROLLER TO TRANSPORT	CONNECTOR/PIN	SIGNAL FUNCTION	
Read Outputs	J202-A	2 ⁰ Read	Write Inputs	J201-A	Write 2 ⁰	
	J202-B	2 ¹ Read		J201-B	Write 2 ¹	
	J202-C	2 ² Read		J201-C	Write 2 ²	
	J202-D	2 ³ Read		J201-D	Write 2 ³	
	J202-E	2 ⁴ Read		J201-E	Write 2 ⁴	
	J202-F	2 ⁵ Read		J201-F	Write 2 ⁵	
	J202-H	Parity bit read		J201-G	Write parity bit	
Write Outputs	J202-M	Write Enable - File protection ring is installed, transport is ready for Write operations.		J201-R	Select Density	
	J202-N	Density reply		J201-S	Select Density	
	J202-P	Density reply		J201-K	Write Select - Enables write and verify operations	
Transport Status	J201-T	Busy - Tape is in motion		J201-H	Write Sprocket - Write information is on input lines	
	J202-L	Tape is at load point		J201-L	Move tape forward at 37-1/2 ips.	
	J202-K	End of tape marker sensed		J201-M	Move tape reverse at 37-1/2 ips.	
	J202-J	Ready and Selected - Transport is under external control.	J201-N	Rewind - Reverse tape at high speed to next load point marker.		
Other Outputs	J202-R	Tape unit address is 0	J201-P	Rewind Unload - Rewind tape at high speed to next load point marker and drop Ready signal.		
	J202-S	Tape unit address is 1	J201-X	Clears Write FF		
	J202-T	Tape unit address is 2	Select Density Codes			
	J202-U	Tape unit address is 3	J201	200	556	800
	J202-V	Tape unit address is 4	S	1	0	1
	J202-W	Tape unit address is 5	R	0	1	1
	J202-X	Tape unit address is 6				
	J202-Z	Tape unit address is 7				
J201-Y	9-TRACK I/O					
Density Reply Codes						
J202	200	556	800			
N	0	1	0			
P	0	0	1			

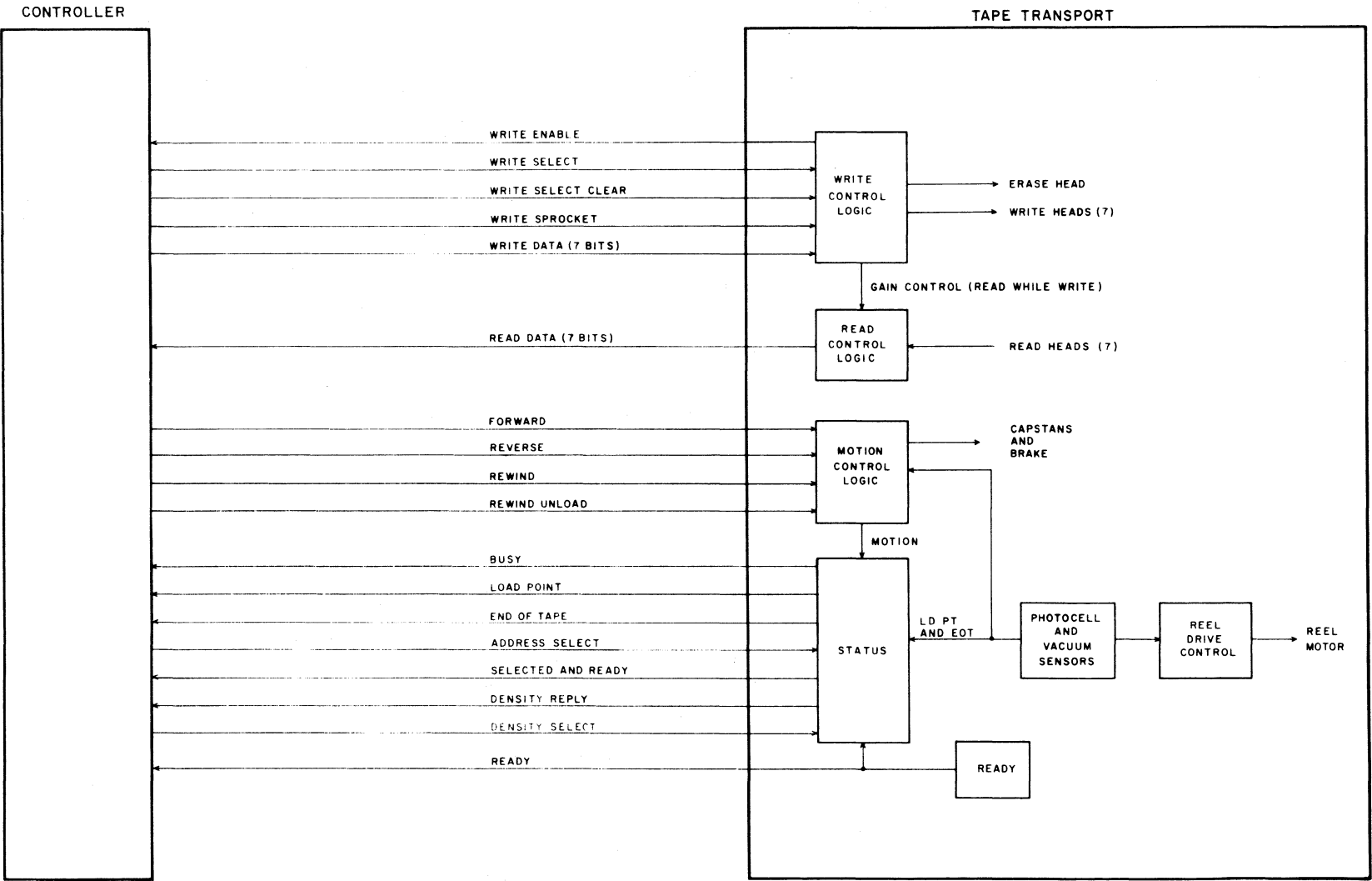

CONTROL DATA		TITLE	
CORPORATION		BLOCK DIAGRAM	
DEVELOPMENT DIVISION		PRODUCT	
		608	
SIZE	DRAWING NO	REV	
C	45712100	A	
SHEET	PAGE		
2	1-3		

TERM LOCATION PAGE

I095	C13C	1-15
I097	D12C	1-13
I114	C23A	1-11
I115	C23C	1-11
I118	B39C	1-7
I122	C38B	1-11
I125	C36C	1-7
I311	C19C	1-13
I400	D35A	1-9
I406	D41A	1-9
I412	D35C	1-9
I413	D25D	1-9
I416	D40C	1-9
I419	C26A	1-9
K090	C12A	1-13
K107	C24C	1-11
K110	C21A	1-11
K112	C21C	1-11
K119	C37C	1-7
K401	D37C	1-9
K402	D32A	1-9
K403	D32C	1-9
L102	D27C	1-7
M108	C32C	1-11
M230	C41C	1-19
Y111	R43C	1-7

SEARCH LOAD POINT CIRCUIT

The Search Load Point circuit controls the Load Tape operation after a loop of tape has been manually fed from the supply to the take-up reel under the magnetic head and the shield pad is closed. When the LOAD switch is pressed, the Set Loops FF is set and the Unloaded FF (refer to Rewind and Unload circuitry) is cleared. Clearing the Unloaded FF energizes the Load relay in the power supply. Energizing the Load relay supplies electrical power to the capstan motors, the high-vacuum pump motor, the low-vacuum motor, and the running time meter.

As the loop box vacuum motor reaches operating speed, the upper loop sensors detect vacuum and close to set the Loop Vacuum Up FF (in the Fault circuit). Setting the Loop Vacuum Up FF produces a 150-ms pulse which energizes the Fault relay. While the Fault relay is energized, the reel motors can be driven. Tape must be driven below the upper fault ports in both vacuum columns within the 150-ms pulse or the Not Fault relay will be de-energized and the reel drive motors braked. When both fault switches close, the Not Fault relay is held energized, the Loop Vacuum Up FF is cleared, and the Search Load Point FF is set.

Until now tape drive has been provided by the reel motors. When the Search Load Point FF is set, the Forward FF is set, vacuum is routed to the forward capstan, and tape is driven forward until the load point is

detected. Detecting the load point or sensing of the lower forward loop sensor clears the Set Loops FF. Two seconds later, after Set Loops has been cleared and if motion has stopped, the Search Load Point FF is cleared and the Not Local signal goes to "1". Not Local is an enabling signal which indicates the transport is ready to be placed on-line. After tape is loaded the Not Local signal remains at "1" until a Rewind operation is selected.

FAULT/CLEAR

The Fault/Clear circuit detects loop fault conditions (stopping tape motion when such faults are detected) and initializes the logic during the Power Up sequence.

The Power Up Clear and the CLEAR switches produce a signal which sets the Fault FF and clears the Set Loops and the Ready FF's. The set output of the Fault FF clears the motion FF's, stopping all motion, and clears the Rewind FF and Search Load Point FF's to initialize the logic before operation begins. When the CLEAR switch is released or the Power Up Clear signal is dropped, the Fault FF is cleared by a 5- μ sec pulse.

TERM LOCATION PAGE

I108	C27C	1-5
I112	C25C	1-5
I122	C38B	1-11
I126	D25C	1-5
I220	C40A	1-19
I304	C18C	1-13
I307	C17C	1-13
I310	C19A	1-13
I311	C19C	1-13
I400	D35A	1-9
I401	D34C	1-9
I408	D41B	1-9
I409	D41C	1-9
I410	D33D	1-9
I411	D35C	1-9
I419	C26A	1-9
K101	C31A	1-5
K102	C30A	1-5
K103	C30C	1-5
K106	C24A	1-11
K107	C24C	1-11
K108	C22A	1-11
K201	C42C	1-19
K401	D37C	1-9
K403	D32C	1-9
M110	D20B	1-11
M300	D19A	1-13

LOAD POINT

The Load Point circuit monitors the output of the load point sensor. As a load point reflective marker passes over the sensor, the output of the photocell amplifier goes to "1". If the signal remains at "1" for more than 1 ms, the circuit produces a 5- μ sec Load Point pulse which clears the Rewind, Set Loops, End of Tape and motion FF's, stopping all tape motion. At the same time, the LOAD indicator on the operator panel lights and (if the unit is on-line) a Load Point signal is sent to the controller. The LOAD indicator remains lit and the Load Point signal remains high as long as the Load Point marker is detected.

END OF TAPE

The End of Tape (EOT) circuit monitors the output of the end of tape sensor. As an EOT reflective marker passes over the sensor, the output of the photocell amplifier goes to "1". If the signal remains a "1" for more than 1 ms while tape is moving forward, the End of Tape FF is set. The End of

Tape FF is cleared when the EOT marker is detected during reverse motion. During local (off-line) operations, forward tape motion immediately stops when the EOT marker is detected. On-line operation is not interrupted when the EOT marker is detected while moving forward, but the End of Tape signal goes to "1", informing the controller that the transport is beyond the EOT. When the End of Tape FF is cleared the EOT signal goes to "0", indicating that the transport is on the usable section of the tape.

READY

The Ready circuit performs an enabling function. When the Ready FF is set, the unit may be selected by the controller and all local commands are disabled. When ready, selected, and not faulted, the Ready line informs the controller the transport is on-line. The Ready FF is cleared by a Clear signal or a Rewind Unload operation selected by the controller removing the transport from computer control.

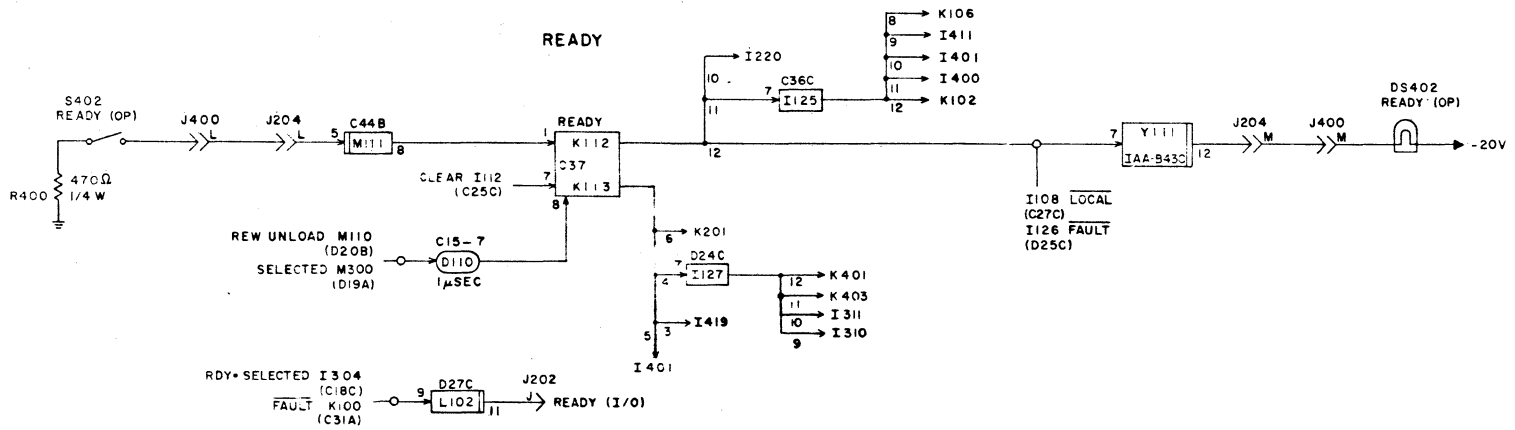
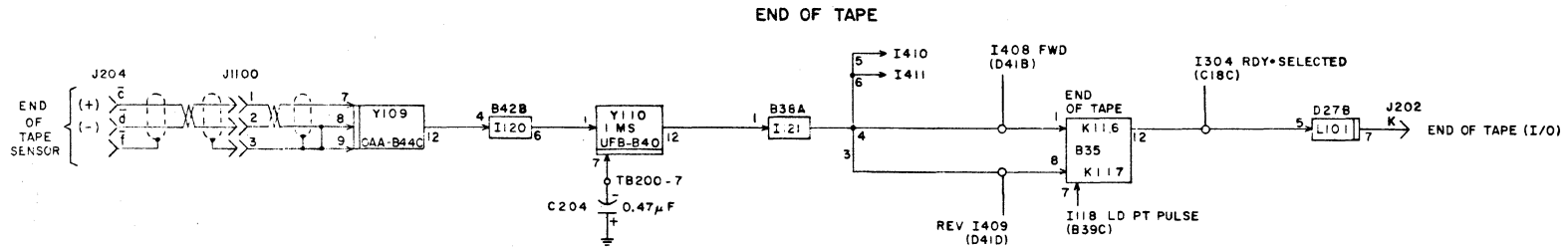
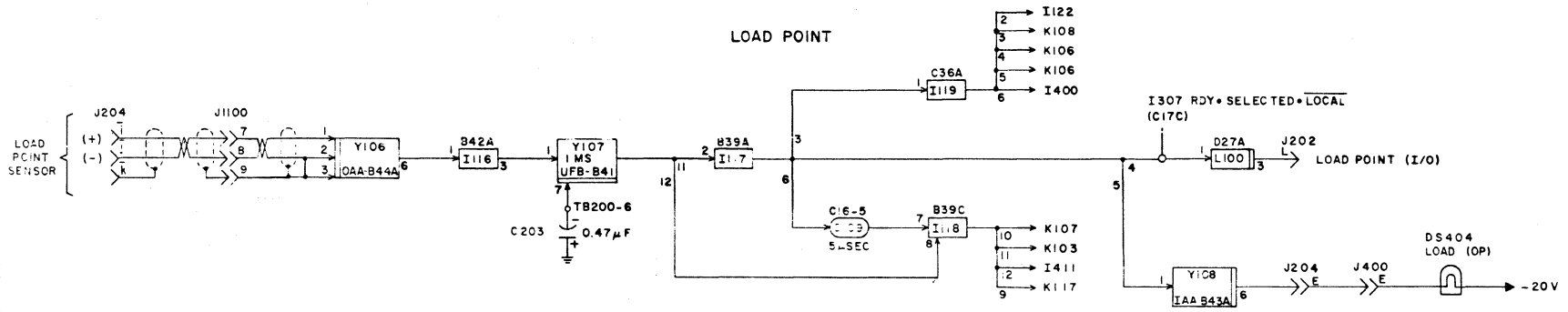

CONTROL DATA DEVELOPMENT DIVISION	TITLE LOAD POINT, END OF TAPE, READY	PRODUCT 608
	SIZE C 45712100	REV AF
SHEET 4	PAGE 1-7	

TERM LOCATION PAGE

I097	D12C	1-13
I104	R38C	1-5
I108	C27C	1-5
I113	D24A	1-5
I114	C23A	1-11
I115	C23C	1-11
I118	R39C	1-7
I119	C36A	1-7
I121	R38A	1-7
I125	C36C	1-7
I127	D24C	1-7
I304	C18C	1-13
I307	C17C	1-13
K091	C12C	1-13
K102	C30A	1-5
K105	C29C	1-5
K106	C24A	1-11
K108	C22A	1-11
K112	C37A	1-5
K116	R35A	1-7
K117	R35C	1-7
L500	R12A	1-17
I501	R12B	1-17
M100	C34A	1-5
M103	C33A	1-5
M108	C32C	1-11

MOTION CIRCUIT

The Motion circuit controls capstan tape drive. The direction of tape drive is determined by which of the capstans receives vacuum and which receives pressure. During any drive condition the tape brake does not have vacuum applied to it. However, when both motion FF's (Forward and Reverse) are cleared and a Rewind operation is not in process the tape brake receives vacuum and tape motion is stopped.

The following conditions produce forward tape drive by the capstans. Because a reverse operation is essentially similar only forward motion is considered.

Forward capstan drive is initiated by setting the Forward FF and terminated when the FF is cleared. The Forward FF is set when:

1. A Search Load Point operation is begun, the Rewind FF is cleared, and the tape is not already at load point.
2. The FORWARD switch on the rear maintenance panel is pressed and the transport is not on-line.
3. A Forward command is received from the controller and the unit is ready and selected. Note that forward motion initiated by the controller continues only when the Forward signal is present. When the Forward signal is dropped the Forward FF is cleared.
4. LOAD switch is actuated and tape is not at load point.

Motion is immediately stopped when both motion FF's are simultaneously cleared. This occurs when:

1. An End of Tape signal is received when the transport is off- and tape is moving forward. This results in a 5- μ sec pulse clear the motion FF's.
2. A fault is detected.
3. A load point is detected.

There is one special case of reverse motion which should be discussed. During a Rewind operation, the routing of vacuum to the reverse caps is determined by the position of the tape loops in the loop boxes. A high-speed motor is driving the capstan and it could easily outrun the reel drive motors if vacuum were continuously held on the capstan. Therefore, vacuum is routed to the capstan only when the tape loop is below the top forward loop sensor and above the lower reverse loop sensor. In the Reel Motor circuit, the conditions which cause capstan drive drop drive voltage to the reel motors. The conditions which drop vacuum on the reverse capstan drives the reel motors. The result is that the tape loop, during a Rewind operation, oscillates slightly above and below the top forward loop sensor and the lower reverse loop sensor.

Any motion (forward, reverse, or rewind) selected while the unit is on line produces a Busy signal to the controller. The Busy signal remains at "1" for 4 ms after the motion signals are dropped. This allows motion to completely stop before new motion is selected. During a Rewind operation the Local signal goes to "0". This holds the Busy signal at "1" until 2 seconds after the load point marker is detected at the end of the Rewind operation.

TERM LOCATION PAGE

I104	R38C	1-5
I105	D33A	1-5
I110	C26C	1-5
I118	R39C	1-7
I119	C36A	1-7
I125	C36C	1-7
I304	C18C	1-13
I401	D34B	1-9
I407	D40A	1-9
I412	C38A	1-9
I415	R42D	1-9
I417	D25A	1-9
K100	C31A	1-5
K104	C31A	1-5
K105	C29C	1-5
K113	C37C	1-7
K115	D31C	1-5
K400	D37A	1-9
M103	C33A	1-5
M105	C33C	1-5
M106	C32A	1-5
Y003	D44C	1-13
Y101	C35C	1-5

REWIND AND UNLOAD

The Rewind and Unload circuit controls the Rewind and Rewind Unload operations. A Rewind operation is initiated when the Rewind FF is set. This is done by a Rewind signal from the controller, a Rewind Unload signal from the controller (which also drops the Ready signal) or, in the off-line mode, by pressing the REWIND switch on the operator panel. If the tape is not at load point the Hi Speed FF is set by a 5- μ sec pulse when the Rewind FF is set. Tape brake vacuum is now disabled and reverse motion begins at a normal speed. If the load point is not detected within 200 ms, the Hi Speed relay is energized and the rewind motor is activated. The high-speed motor overrides the low-speed reverse capstan motor and the Rewind operation proceeds at high speed. Note that the reel motor brakes are also disabled when the 200-ms delay times out. Refer to the Motion Control circuit explanation of the high-speed reverse operation.

Tape motion continues in reverse at high speed until the load point is detected. A load point pulse clears the Rewind FF and the Hi Speed FF. The tape brake is again enabled and the Hi Speed relay is de-energized, enabling the reel motor brakes and de-energizing the rewind motor. Because of the high tape speed prior to detecting load point, the marker is carried past the sensor and must be relocated. A Search Load Point operation (initiated when the Search Load Point FF was set at the beginning of the Rewind operation) positions the marker over the sensor.

An Unload operation is initiated when the Rewind FF is set while the tape is at load point. Low speed reverse motion continues until all the tape is drawn off the forward reel. The resulting loop fault sets the Unloaded FF, which de-energizes the Load relay and drops power to the capstans, pump motor, and low pressure/vacuum motor.

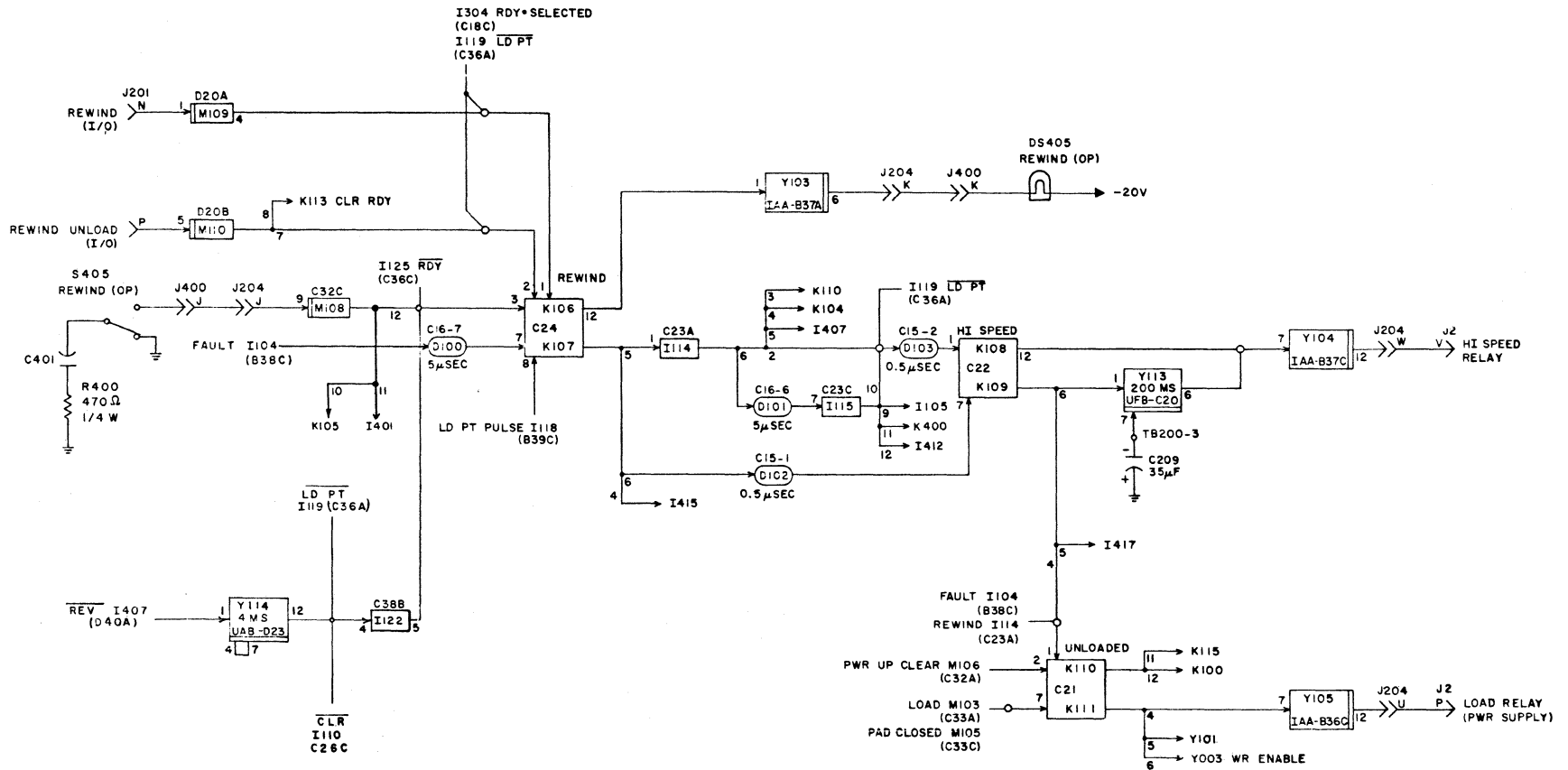

CONTROL DATA		TITLE	PRODUCT
DEVELOPMENT DIVISION		REWIND AND UNLOAD	608
		SIZE	DRAWING NO
		C	45712100
		REV	AF
		SHEET	PAGE
		6	1-11

TERM LOCATION PAGE

I090	D13A	1-15
I091	D13C	1-15
I095	C13C	1-15
I107	C25A	1-5
I127	D24C	1-7
I221	C40C	1-19
I400	D35A	1-9
I401	D34C	1-9
I407	D40A	1-9
K100	C31A	1-5
K106	C24A	1-11
K110	C21A	1-11
K113	C37C	1-7
L100	D27A	1-7
L101	D27B	1-7
L102	D27C	1-7
L201	D28B	1-19
L400	D26B	1-9
M402	D19B	1-9
Y501	A17	1-17
Y503	B09	1-17
Y511	A15	1-17
Y513	B08	1-17
Y521	A13	1-17
Y523	B07	1-17
Y531	A11	1-17
Y533	E08	1-17
Y541	A09	1-17
Y543	B05	1-17
Y551	A07	1-17
Y553	B04	1-17
Y581	A01	1-17
Y583	B01	1-17

WRITE ENABLE

The Write Enable circuit specifies the conditions which must be present for a Write operation to take place. These conditions, in their normal order of occurrence, are:

1. A write ring is installed in the tape reel.
2. The unit is Ready and Selected.
3. A Write Enable signal is on line to the controller.
4. A Write Select is received from the controller. This signal must be present throughout the Write operation.

The write ring closes the Write Enable switch, energizing the Write Enable relay (K200). This forces a "1" out of M091 and, if the unit is both Ready and Selected, places a Write Enable signal on line to the controller. The WRITE ENABLE indicator is lighted and the Write Enable solenoid is activated. The Write Enable solenoid holds the WRITE ENABLE switch arm from contacting the back of the tape reel and holds the Write Enable relay energized.

Once the Write Enable signal is present and the transport is Ready, Selected, and Not Local, a Write Select signal sets the Write FF. The outputs of the Write FF, when set, drop the constant clear that is held on the Write Data FF's (in the Write circuit) during a non-write condition and provide a reference threshold voltage to the level detector cards in the Read circuit. A "0" into Y001 in the Write Enable circuit turns on the write power transistor in the Write circuit and provides erase current to the erase head and write current to the write heads.

SELECT

The Select circuit performs an enabling function throughout the transport logic. A Select signal must be received from the controller and held on line before any other commands from the controller will be answered. The transport must be ready before a Select signal will be accepted.

The Unit Select switch is set to any of eight addresses (0-7). A +2v ("1") level signal on the line to which the switch is set selects the transport.

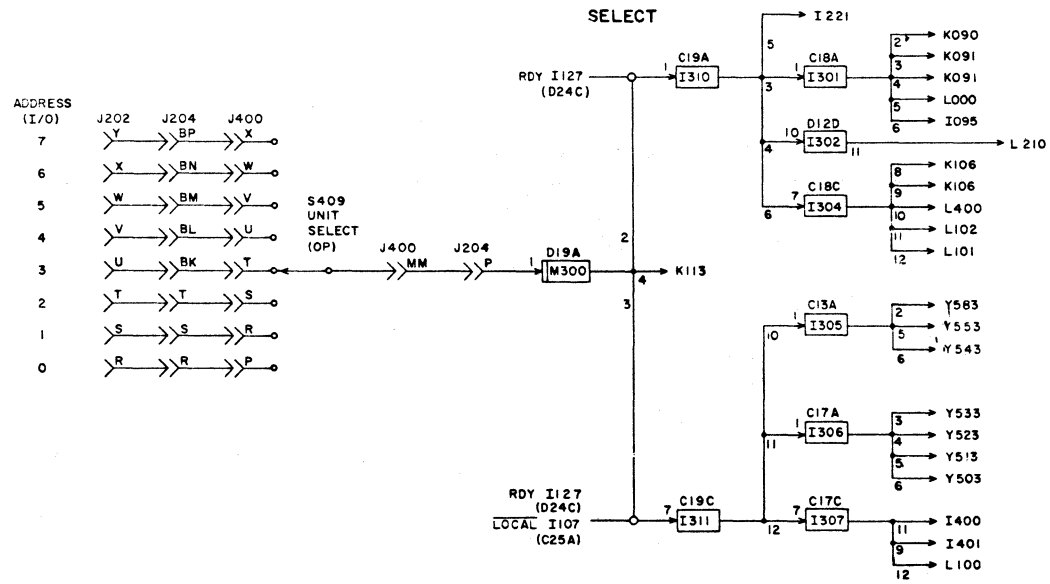
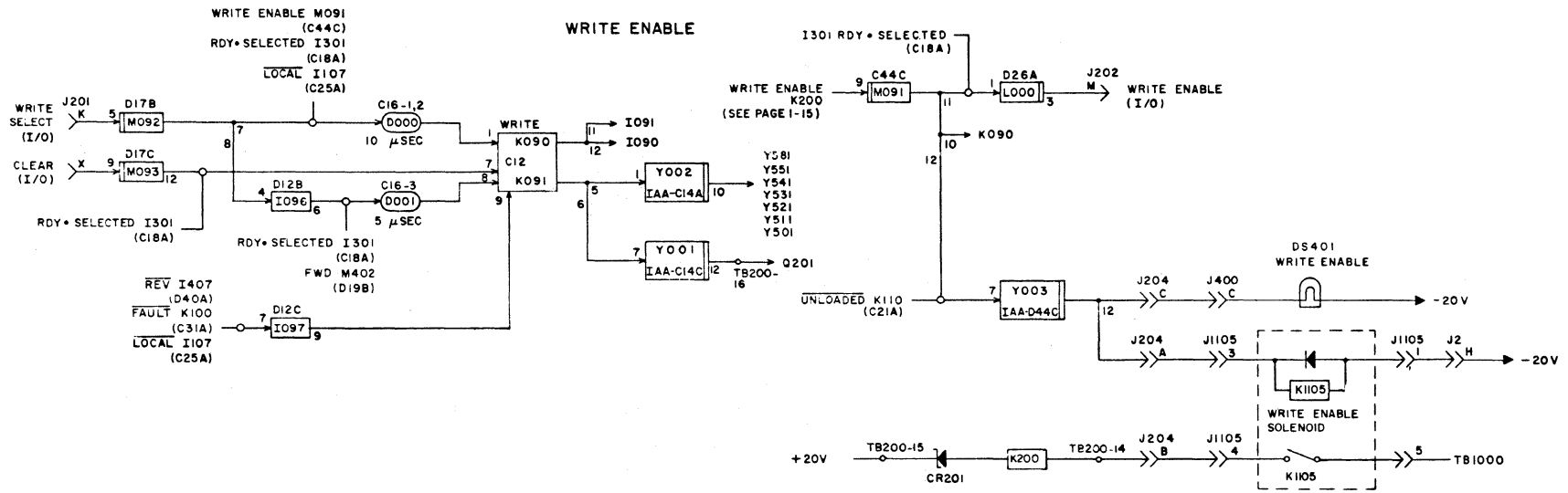

CONTROL DATA	TITLE	PRODUCT
	WRITE ENABLE AND SELECT	608
	DEVELOPMENT DIVISION	SIZE DRAWING NO
		C 45712100
	SHEET 7	PAGE 1-13

TERM LOCATION PAGE

I107	C25A	1-5
I301	C18A	1-13
K091	C12C	1-13
M091	C44C	1-13
Y001	C14C	1-13

WRITE

The Write circuit receives write data from the controller and converts it into magnetic flux changes on tape. Data is received in NRZI format on seven input lines (six information, one parity). A sprocket pulse is received with each data frame. Sprocket and data timing varies according to the density being recorded.

Prior to a Write operation and again when the Write operation stops, the Write Data FF's are held clear. A Write signal drops the clear on the Write Data FF's. A Write Enable signal turns on the write power transistor (Q201) to provide erase current and write current.

A sprocket signal from the controller accompanies each frame of data. The sprocket signal is converted to enabling pulses for the data inputs to each Write Data FF. The timing of the enabling pulses is adjusted to compensate for write head skew so a data frame is aligned vertically on the tape. A "1" information bit is recorded on the tape each time the Write Data FF changes state. When the Write Data FF changes state it realigns the magnetic particles in the tape coating. These changes in alignment are detected by the read head. Refer to Figure 5-1 for the Write circuit timing.

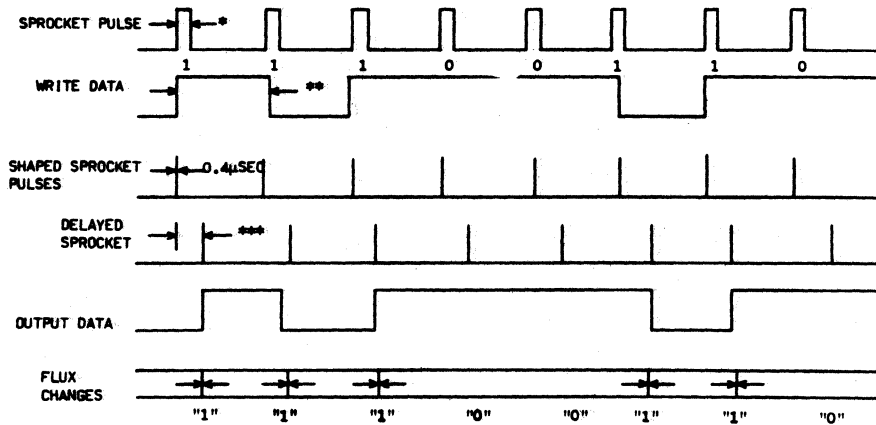

* WRITE SPROCKET PULSES $4.0\mu\text{SEC}$ minimum, $1/2$ write time maximum

** WRITE TIME $133.2\mu\text{SEC}$ at 200cpi

$47.9\mu\text{SEC}$ at 556cpi

$33.3\mu\text{SEC}$ at 800cpi

***SKEW DELAY $5.0\mu\text{SEC}$ minimum, $12\mu\text{SEC}$ maximum

(adjusted to vertically align characters in each frame)

4E4

Figure 5-1. Write Timing

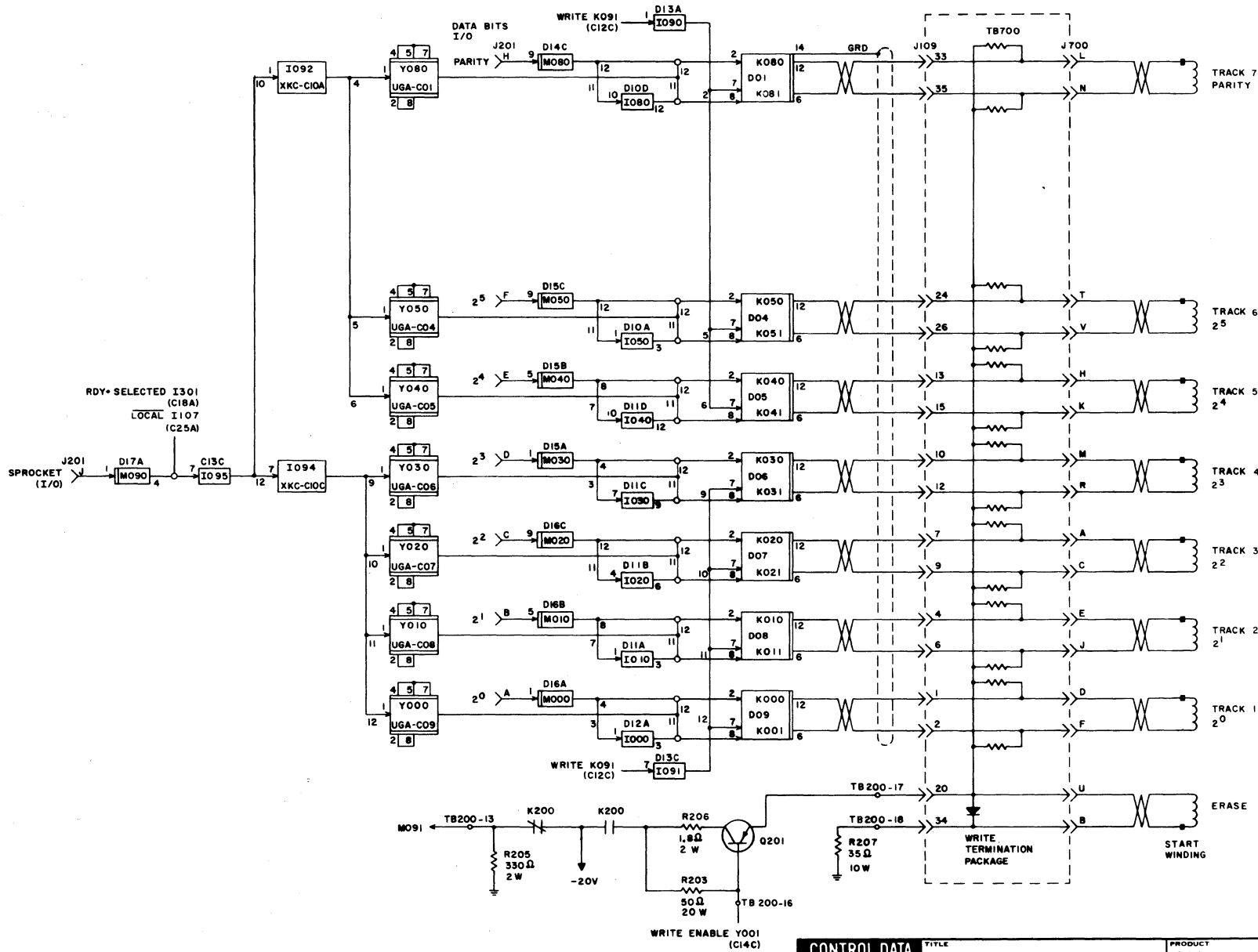

CONTROL DATA
 DEVELOPMENT DIVISION

TITLE
 WRITE

PRODUCT 608	
SIZE C	DRAWING NO. 45712100
SHEET 8	REV. AE
PAGE 1-15	

TERM LOCATION PAGE

I305	C13A	1-13
I306	C17A	1-13
K401	D37C	1-9
K403	D32C	1-9
Y002	C14A	1-13

READ

The Read circuits detect, convert, and route information from the tape to the controller. Data detected by the read heads is amplified, rectified, and compared to a reference voltage. A 3/4- μ sec "1" pulse is produced for each "1" on tape. Delay circuits electrically compensate for the electrical/mechanical skew of the recorded data (Figure 5-2). All bits in a frame are placed on the output lines within 2 μ sec of one another.

The level shift network provides the reference voltage to which the read signal is compared. The network is an emitter follower with a variable output attenuator. A zener voltage regulator in the read preamp provides 2.8-vdc bias to the base of Q20[^]. The output level is adjusted by adjusting the output resistance. This level is applied to the read level detector as an input reference voltage. Read signals which are higher than the reference are passed to the peak detector. Signals lower than the reference are blocked. This excludes random noise from being detected as data. During a Read after Write operation, a reference voltage higher than normal is used to ensure that a strong signal is recorded.

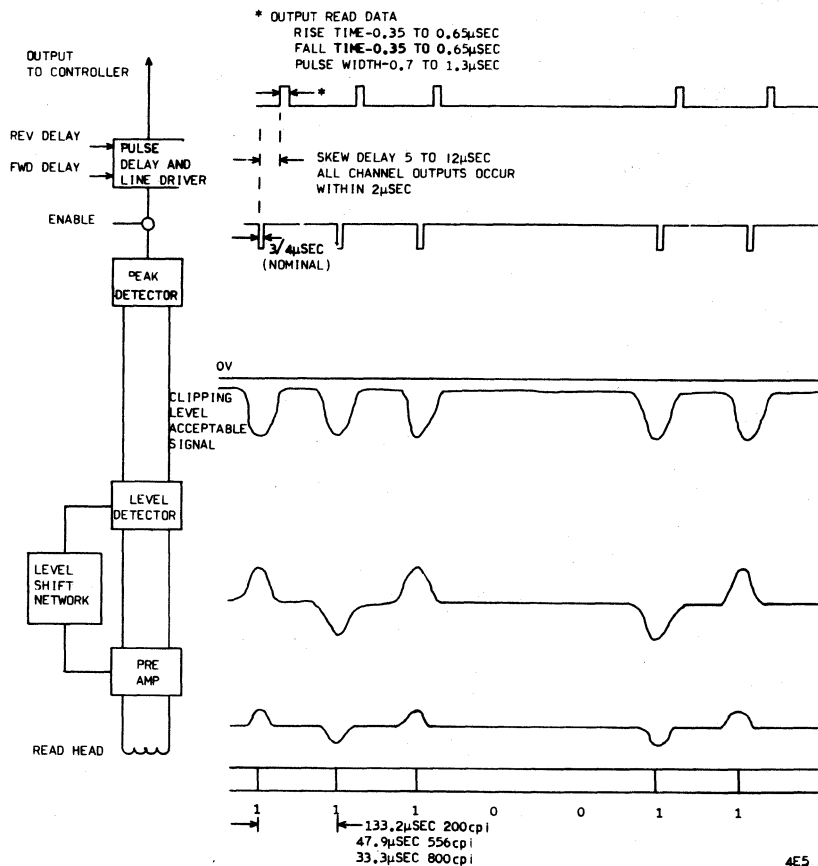
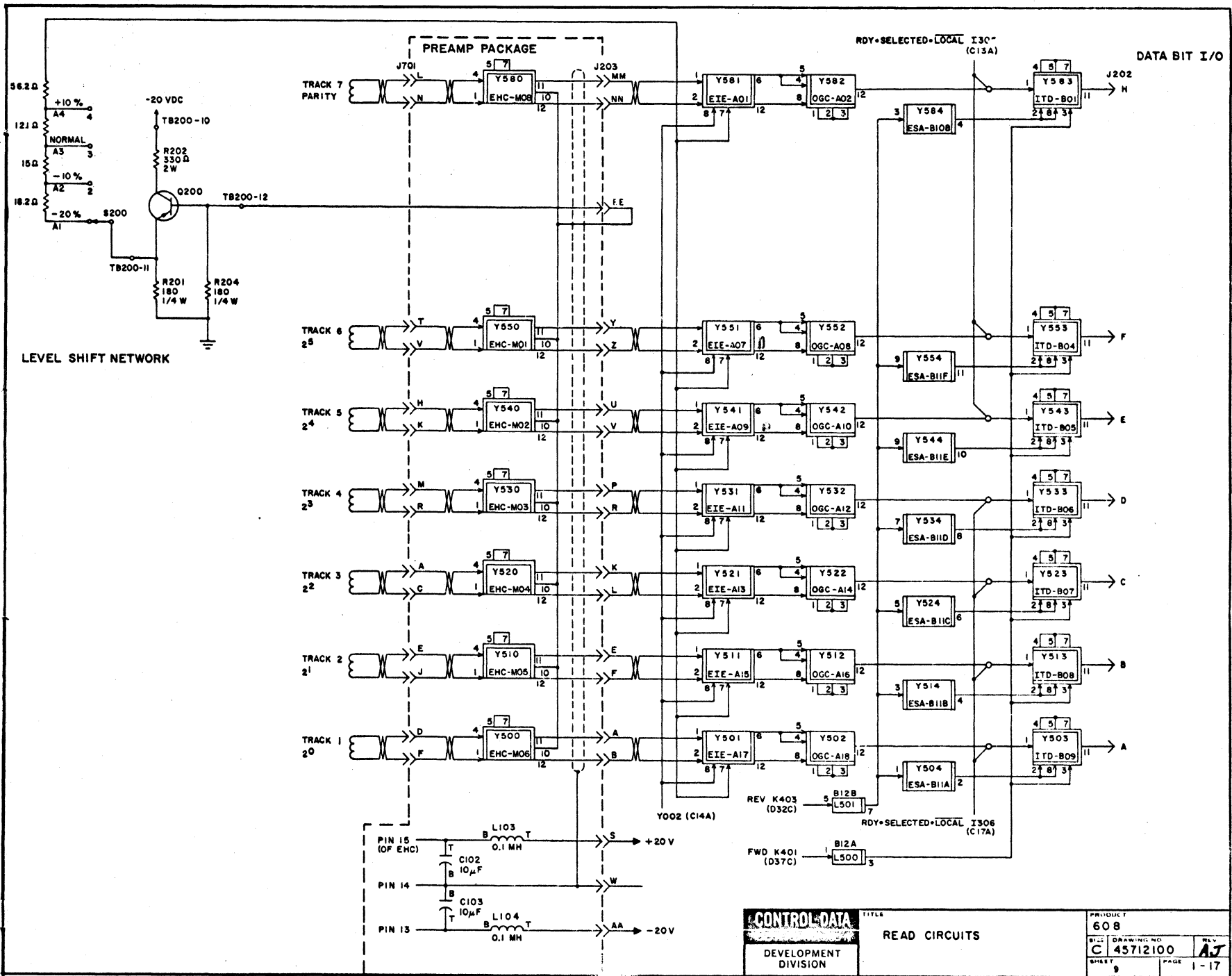

Figure 5-2. Read Timing



CONTROL-DATA		TITLE	PRODUCT
DEVELOPMENT DIVISION		READ CIRCUITS	608
BL: C	DRAWING NO: 45712100	REV: AJ	
SHEET: 9	PAGE: 1-17		

TERM LOCATION PAGE

I302	D12D	1-13
I310	C19A	1-13
K112	C37A	1-7
K113	C37C	1-7
M106	C32A	1-5

DENSITY

The Density circuit allows the operator to inform the tape controller of the character density of the tape being read. The inputs from the controller inform the operator of the density being recorded on the tape. The Power Up Clear automatically lights the 800 BPI indicator on the operator panel and sends an 800 bpi density reply to the controller.

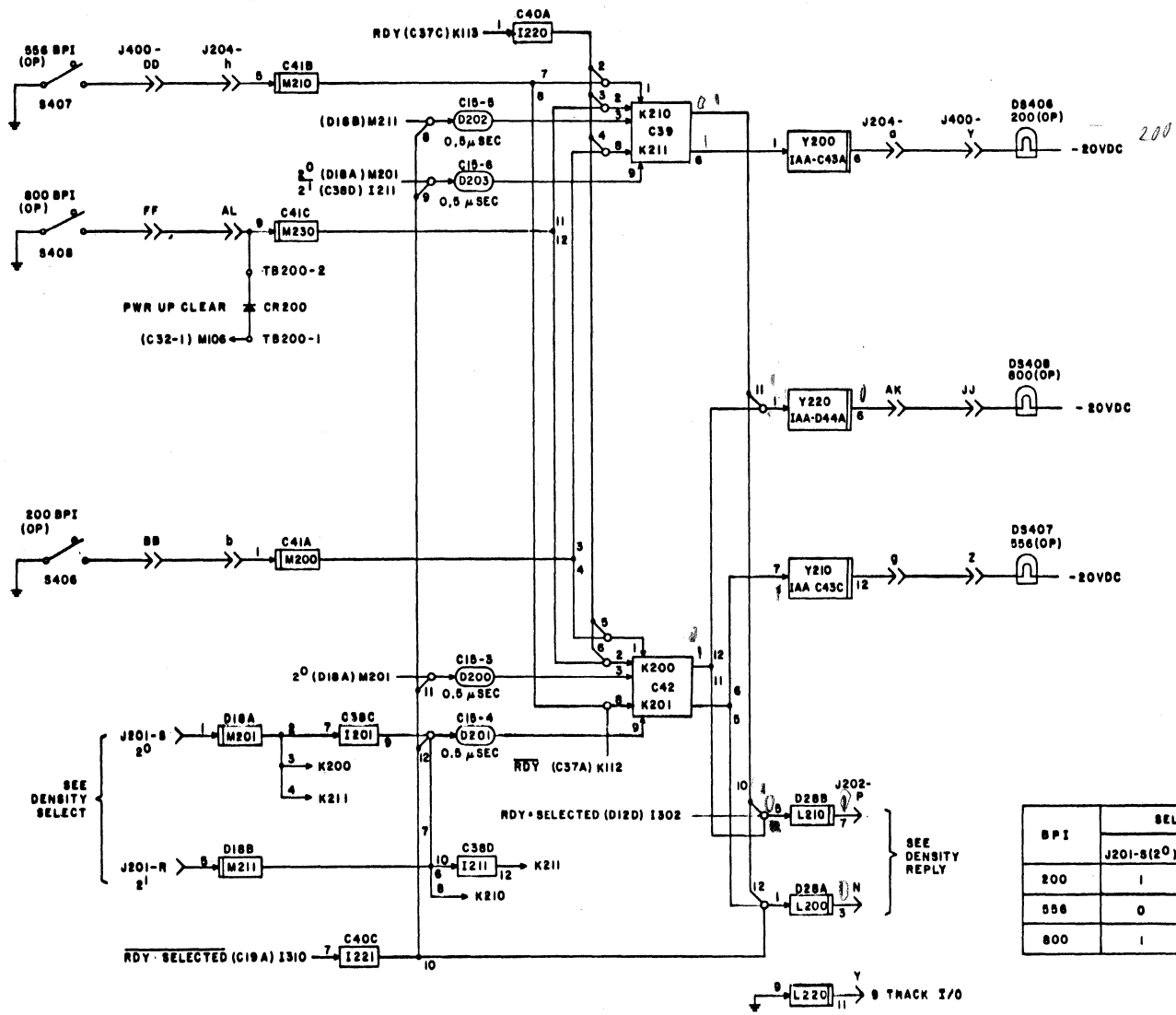

DENSITY

BPI	SELECT		REPLY	
	J201-S(2 ⁰)	J201-R(2 ¹)	J202-N	J202-P
200	1	0	0	0
556	0	1	1	0
800	1	1	0	1

CONTROL DATA CORPORATION	TITLE	PRODUCT
	DENSITY	608
	DEVELOPMENT DIVISION	SIZE DRAWING NO REV
		C 45712100 AD
		SHEET 10 PAGE 1-19



	1	2	3	4	5	6	7	8	9	10	11	12	13	14	15	16	17	18	19	20	21	22	23	24	25	26	27	28	29	30	31	32	33	34	35	36	37	38	39	40	41	42	43	44								
A	Y	Y					Y	Y	Y	Y	Y	Y	Y	Y	Y	Y	Y	Y																																		
	5	5					5	5	5	5	5	5	5	5	5	5	5	5																																		
	8	8					5	5	4	4	3	3	2	2	1	1	0	0																																		
	1	2					1	2	1	2	1	2	1	2	1	2	1	2																																		
	EZE	OBC					EZE	OBC	EZE	OBC	EZE	OBC	EZE	OBC	EZE	OBC	EZE	OBC																																		
B	Y		Y	Y	Y	Y	Y	Y	Y	Y																																										
	5		5	5	5	5	5	5	5	5																																										
	8		5	4	3	2	1	0																																												
	3		3	3	3	3	3	3																																												
	ITD		ITD	ITD	ITD	ITD	ITD	ITD	ITD	ITD	ESA	ESA	69																																							
C	Y		Y	Y	Y	Y	Y	Y	Y	Y	I	O																																								
	0		0	0	0	0	0	0	0	0	9	9																																								
	8		5	4	3	2	1	0																																												
	0		0	0	0	0	0	0	0	9	9	0																																								
	USA		USA	USA	USA	USA	USA	USA	USA	XKC	33	21	IAA	EIT	CC62-	21	21	21	UPB	32	31	21	33	21	22	21	UPB	33	33	33	87	87	87	IAA	21	32	20	33	21	87	33	IAA	87									
D	K		K	K	K	K	K	K	K	K																																										
	0		0	0	0	0	0	0	0	0																																										
	8		5	4	3	2	1	0																																												
	0		0	0	0	0	0	0	0	0																																										
	IAA		IAA	IAA	IAA	IAA	IAA	IAA	IAA	IAA	20	20	20	21	OSD	OSD	OSD	OSD	OSD	OSD	OSD	OSD	OSD	OSD	OSD	OSD	OSD	OSD	OSD	OSD	OSD	OSD	OSD	OSD	OSD	OSD	OSD	OSD	OSD	OSD	OSD	OSD	OSD	OSD	OSD	OSD	OSD	OSD	OSD	OSD	OSD	

CONTROL DATA CONTRAFLEXION	TITLE	608
	DEVELOPMENT DIVISION	CARD PLACEMENT
PROJECT	608	
SIZE	DRAWING NO	REV
C	45712100	AK
SHEET	11	PAGE
		1-21



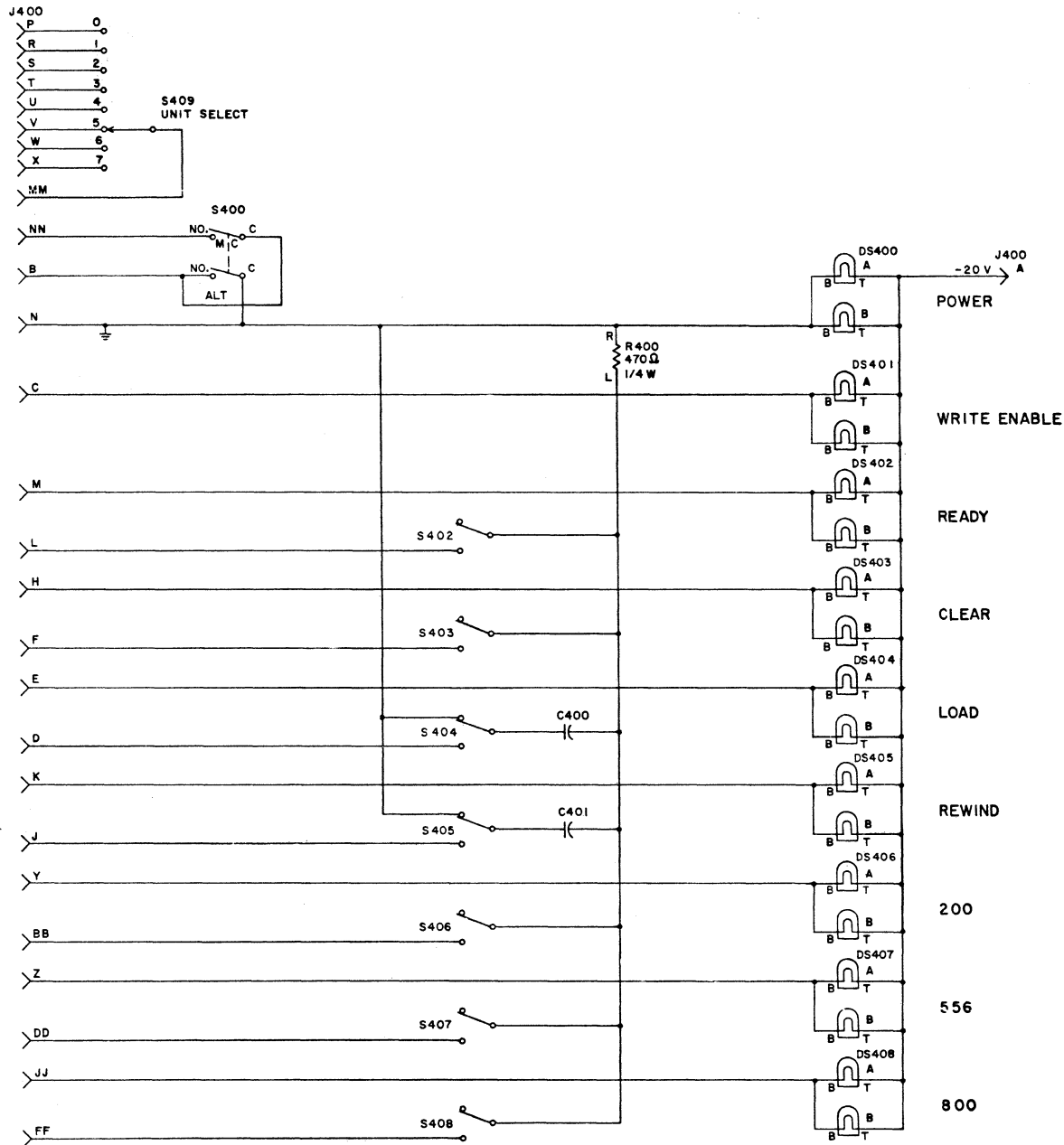

CONTROL DATA
DEVELOPMENT
DIVISION

TITLE
OPERATOR PANEL

PRODUCT 608		REV <i>AF</i>
SIZE C	DRAWING NO. 45712100	PAGE 1-23
SHEET 12		

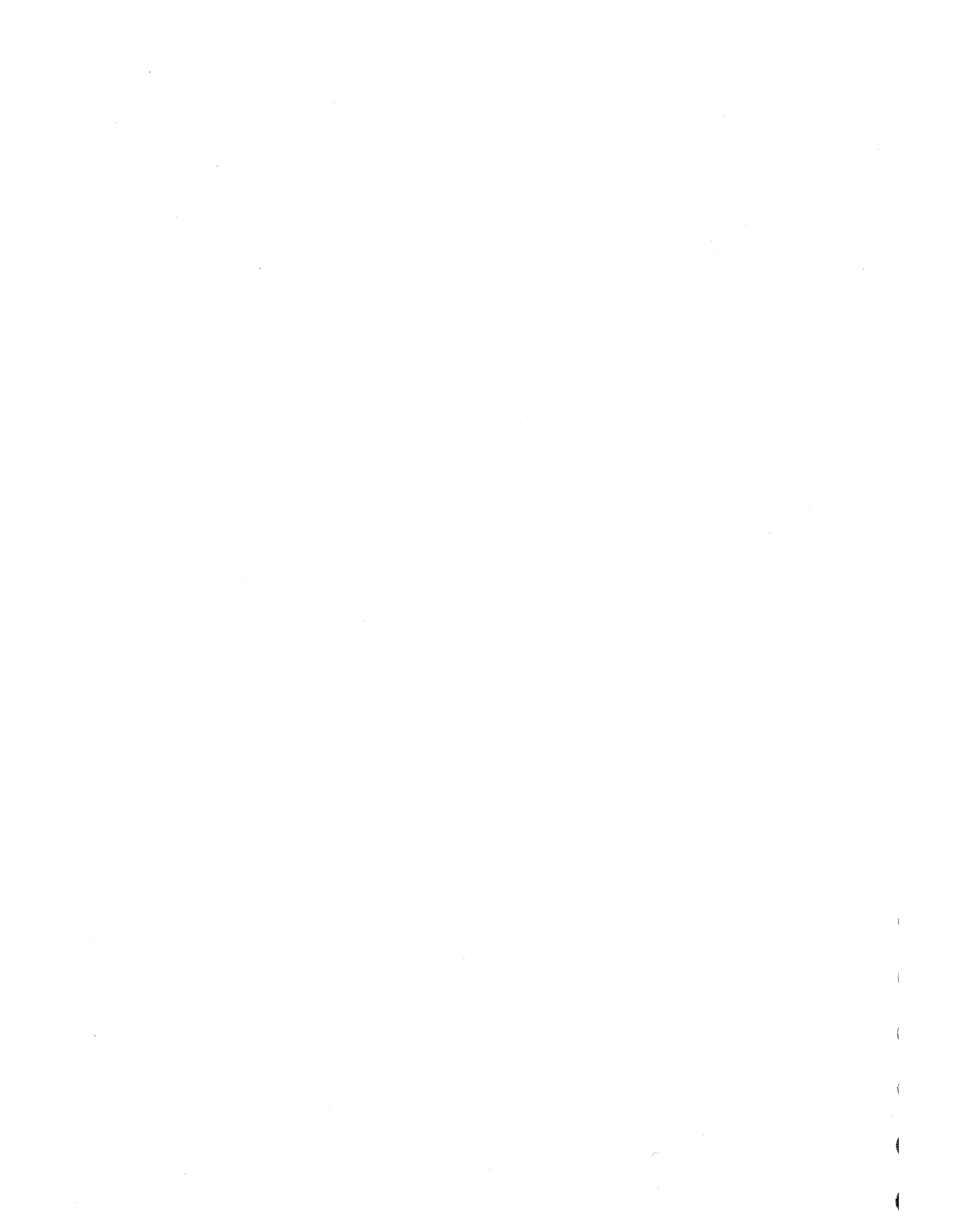

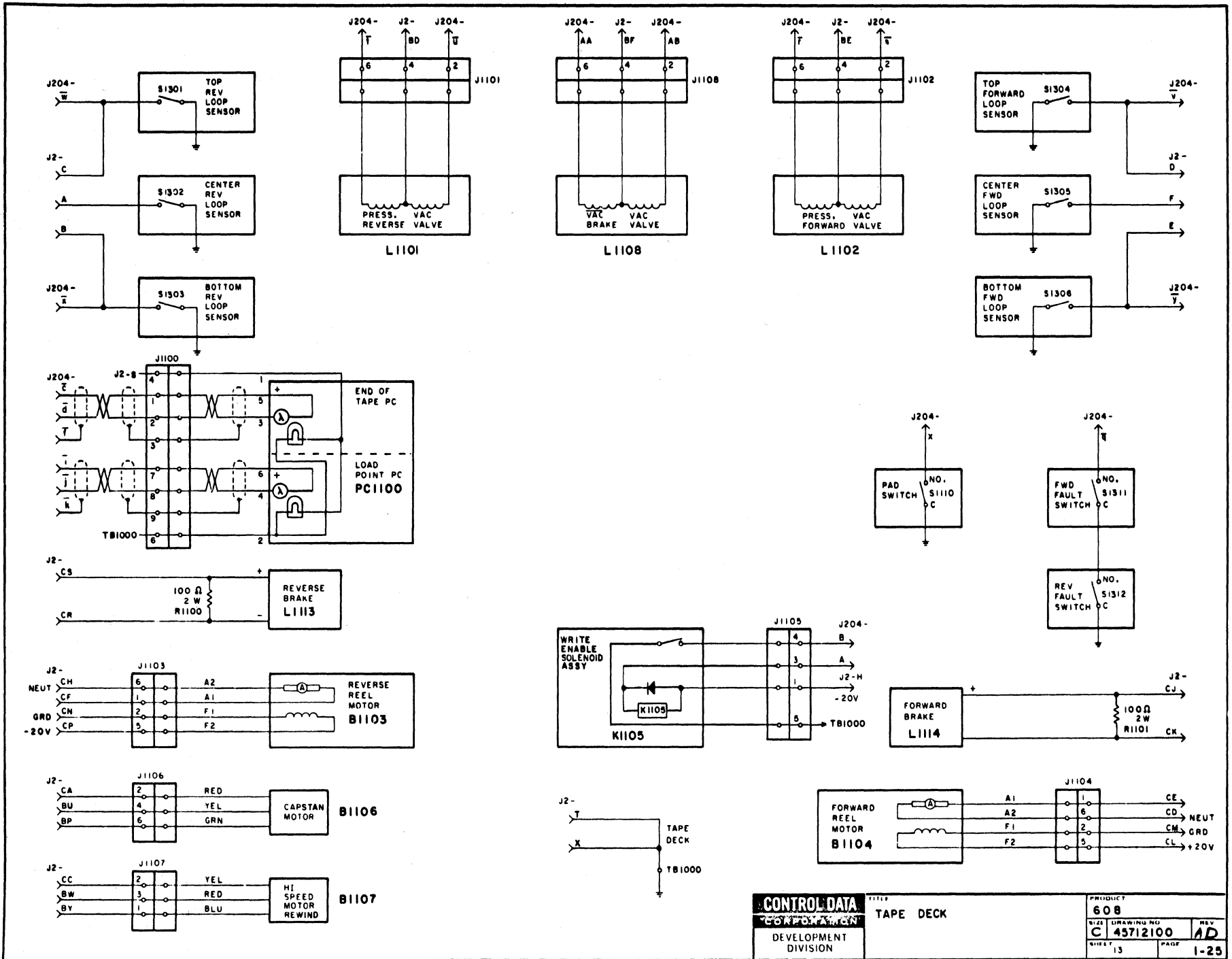

CONTROL DATA CORPORATION DEVELOPMENT DIVISION	TITLE TAPE DECK	PRODUCT 608	
	SIZE C	DRAWING NO. 45712100	REV. AD
	SHEET 13	PAGE 1-25	



J204			J204			J2			J2		
A	J1105-3	WRITE ENABLE SOLENOID	AJ	J2-M	+20V FROM PS C200 (+)	A	S1302-NO,	REV CENTER LOOP SENSOR	AJ		
B	J1105-4	WRITE ENABLE SWITCH	AK	J400-JJ	DS408 800 BPI LIGHT	B	S1303-NO,	REV BOTTOM LOOP SENSOR	AK		
C	J400-C	DS 401 WRITE ENABLE LIGHT	AL	J400-FF	S408 800 BPI SWITCH	C	S1301-NO,	REV TOP LOOP SENSOR	AL		
D	J400-D	S 404 LOAD SWITCH	AM			D	S1304-NO,	FWD TOP LOOP SENSOR	AM		
E	J400-E	DS 404 LOAD LIGHT	AN			E	S1306-NO,	FWD BOTTOM LOOP SENSOR	AN		
F	J400-F	S 403 CLEAR SWITCH	AP			F	S1305-NO,	FWD CENTER LOOP SENSOR	AP		
H	J400-H	DS 403 CLEAR LIGHT	AR			H	J1105-1	WRITE ENABLE SOLENOID-20V	AR		
J	J400-J	S 405 REWIND SWITCH	AS			J	J400-A	OPERATOR CONTROL PANEL-20V	AS		
K	J400-K	DS 405 REWIND LIGHT	AT			K	J204-AH	-20V TO LOGIC CHASSIS	AT		
L	J400-L	S 402 READY SWITCH	AU			L	J204-Z	+20V TO LOGIC CHASSIS	AU		
M	J400-M	DS 402 READY LIGHT	AV			M	J204-AJ	+20V TO LOGIC CHASSIS	AV		
N	J400-N	GRD	AW			N	J204-AF	-20V TO LOGIC CHASSIS	AW		
P	J400-MM	S409-C UNIT SELECT	AX			P	J204-U	LOAD RELAY K1	AX		
R	J400-P	S409-O UNIT SELECT	AY			R	J204-V	FAULT RELAY K1002	AY		
S	J400-R	S409-1 UNIT SELECT	AZ			S	PC1100-1	PHOTO CELL ASSY	AZ		
T	J400-S	S409-2 UNIT SELECT	BA			T	TB1000	TAPE DECK GRD	BA		
U	J2-P	LOAD RELAY K1	BB			U	J400-B	S400-NO, ALT PWR ON OP	BB		
V	J2-R	FAULT RELAY K1002	BC			V	J204-W	HI SPEED RELAY K1001	BC		
W	J2-V	HI SPEED RELAY K1001	BD			W	J204-AD	POWER ON MASTER CLEAR	BD	J1101-4	REV VALVE
X	S1110-NO,	PAD SWITCH	BE			X	TB1000	TAPE DECK GRD	BE	J1102-4	FWD VALVE
Y			BF			Y	J400-NN	S400-NO, M.C. PWR ON	BF	J1108-1	BRAKE VALVE
Z			BH			Z			BH	J507-5	PUMP MOTOR <i>δ</i> C
a	J400-Y	DS406 200 BPI LIGHT	BJ			a			BJ	J507-4	PUMP MOTOR <i>δ</i> B
b	J400-BB	S406 200 BPI SWITCH	BK	J400-T	S409-3 UNIT SELECT	b			BK	J1003-3	HOOR METER
c	J -1100-5	END OF TAPE (+)	BL	J400-U	S409-4 UNIT SELECT	c			BL	J1003-1	HOOR METER
d	J -1100-3	END OF TAPE (-)	BM	J400-V	S409-5 UNIT SELECT	d			BM	J506-3	3 <i>δ</i> BLOWER <i>δ</i> C
e	SHIELD	END OF TAPE	BN	J400-W	S409-6 UNIT SELECT	e			BN	J507-3	PUMP MOTOR <i>δ</i> A
f	J400-Z	DS407 556 BPI LIGHT	BP	J400-X	S409-X UNIT SELECT	f			BP	J1106-6	CAPSTAN MOTOR (GRN) <i>δ</i> B
g	J400-00	S407 556 BPI SWITCH	BR			g			BR	J505-3	COOLING MOTOR <i>δ</i> C
h	J -1100-6	LOAD POINT (+)	BS			h			BS	J506-2	3 <i>δ</i> BLOWER B
i	J -1100-4	LOAD POINT (-)	BT			i			BT	J506-6	1 <i>δ</i> BLOWER <i>δ</i> C
j	SHIELD	LOAD POINT	BU			j			BU	J1106-4	CAPSTAN MOTOR (YEL) <i>δ</i> C
k	S1107-1	FORWARD FMP	BV			k			BV	J505-2	COOLING MOTOR <i>δ</i> B
l	S1108-1	CLEAR FMP	BW			l			BW	J1107-3	1 <i>δ</i> REW MOTOR (RED)
m	S1109-1	REVERSE FMP	BX			m			BX	J506-5	1 <i>δ</i> BLOWER NEUT
n	S1311-NO,	FAULT SWITCH	BY			n			BY	J1107-1	1 <i>δ</i> REW MOTOR (BLU) NEUT
o	J1102-6	FORWARD VALVE (PRESS.)	BZ			o			BZ	J506-1	3 <i>δ</i> BLOWER <i>δ</i> A
p	J1102-2	FORWARD VALVE (VAC)	CA			p			CA	J1106-2	CAPSTAN MOTOR (RED) <i>δ</i> A
q	J1101-6	REVERSE VALVE (PRESS.)	CB			q			CB	J505-1	COOLING MOTOR <i>δ</i> A
r	J1101-2	REVERSE VALVE (VAC)	CC			r			CC	J1107-2	1 <i>δ</i> REW MOTOR (YEL) <i>δ</i> B
s	S1304-NO,	TOP FWD LOOP SENSOR	CD			s			CD	J1104-6	FWD REEL ARM A2 NEUT
t	S1301-NO,	TOP REV LOOP SENSOR	CE			t			CE	J1104-1	FWD REEL ARM A1
u	S1303-NO,	BOTTOM REV LOOP SENSOR	CF			u			CF	J1103-1	REV REEL ARM A1
v	S1306-NO,	BOTTOM FWD LOOP SENSOR	CH			v			CH	J1103-6	REV REEL ARM A2 NEUT
w	J2-L	+20 FROM PS C201 (+)	CJ			w			CJ	L1114-(+T)	FWD REEL BRAKE
x	J1108-6	BRAKE VALVE OPTION (VAC)	CK			x			CK	L1114-(-)B	FWD REEL BRAKE
y	J1108-2	BRAKE VALVE OPTION (VAC)	CL			y			CL	J1104-5	FWD REEL FIELD F2 +20V
aa	J2-W	POWER ON MASTER CLEAR	CM			aa			CM	J1104-2	FWD REEL FIELD F1 GRD
ab			CN			ab			CN	J1103-2	REV REEL FIELD F1 GRD
ac			CP			ac			CP	J1103-5	REV REEL FIELD F2 -20V
ad	J2-N	-20V FROM PS C201(-)	CR			ad			CR	L1113-(-)B	REV REEL BRAKE
ae	J2-K	-20V FROM PS C201(-)	CS			ae			CS	L1113-(+T)	REV REEL BRAKE
af						af					
ah						ah					

POWER ON

Power is applied to the unit by pressing the POWER switch on the operator panel. This applies a ground to J2-Y to complete the circuit through the coil of Power On relay K2 to the secondary of transformer T3. Relay K2 contacts close and power is applied to the cooling fans, to the dc power panel, and the reel motors.

When +20 vdc is available from the dc power panel, Holding relay K30 energizes. Contacts of K30 then act as holding contacts to bypass the POWER ON switch by applying ground through J2-U.

POWER ON MASTER CLEAR

Before relay K2 energizes, normally closed contacts 4B and 4C have maintained capacitor C30 at ground. This ground is applied to the logic to set up the necessary preliminary starting conditions. When -20 vdc becomes available from the dc power panel, C30 continues to hold the ground potential on J2-W until it is charged through R31. When fully charged (about 2 seconds), its negative potential represents a "1", effectively removing the Master Clear signal. Resistor R30 is a surge resistor and also provides a discharge path for C30 when power is removed.

LOAD

Load Relay K1 is energized by pressing the LOAD switch on the operator panel. This applies three-phase power to the capstan motor, hour meter, rotary pump motor, and vacuum blower.



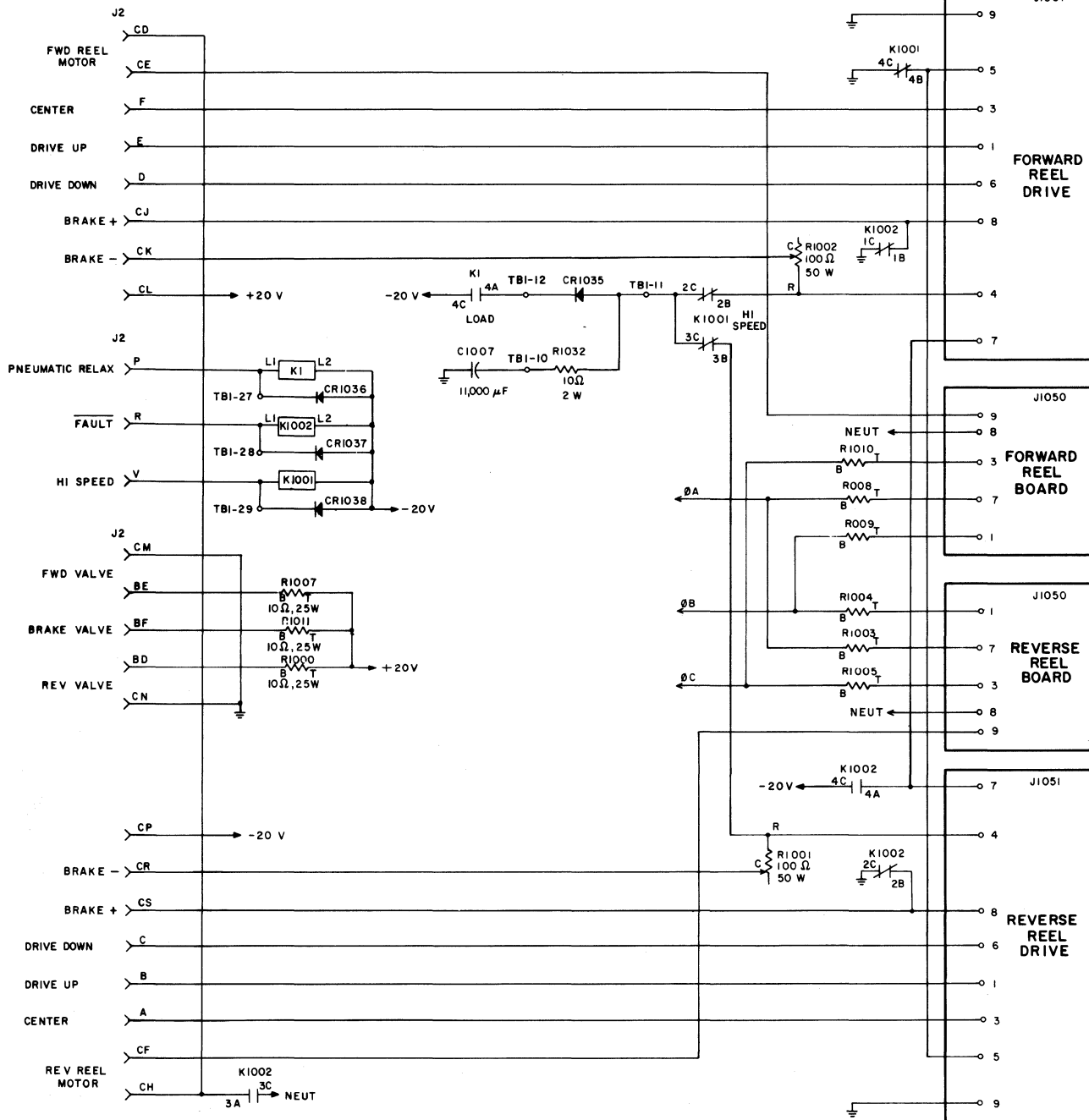
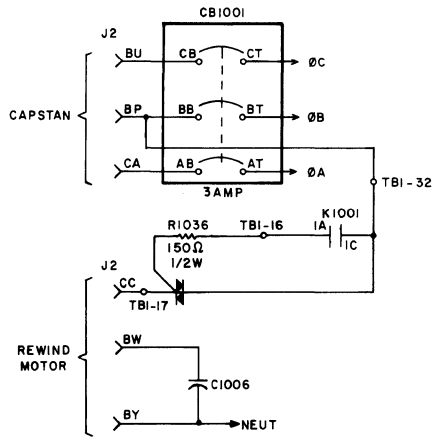

PRODUCT	608
SIZE	C
DRAWING NO.	45712100
REV.	A/S
PAGE	16
SHEET	1-31

TITLE: POWER SUPPLY 2

CORPORATION: CONTROL DATA

DEVELOPMENT DIVISION

REEL SERVO LOOP

This circuit controls the reel servo motors and brakes. They are disabled when the unit is either faulted or not loaded. With Not Fault relay K1002 de-energized, the reel brakes are grounded and the path to neutral for the three-phase power is open to turn off the reel motors.

Assume that a Drive Down condition is required for the forward reel motor. A Drive Down command is necessary whenever tape goes above the forward top loop sensor. Switch S1304 then senses vacuum and closes. This completes the circuit from ground, through S1304, through the coil of relay K50, to -20 vdc (Enable Reel Motors). Relay K50 energizes.

Prior to closing S1304, the brakes were on because PNP transistor Q50 was biased on by -20 vdc through Load relay contacts 4C and 4A. It then conducted current to energize the brakes. When S1304 closes, however, an alternate path to ground is provided through diode CR58. Transistor Q50 turns off and the brakes are released.

Simultaneously with brake release, the three sets of relay K50 contacts in the SCR circuits close. During the positive half of the phase A voltage (applied to J50-7), both the anode and gate of SCR50 are forward biased. SCR50 conducts to apply a positive dc current through the forward reel motor armature. When phase A swings negatively, the gate is broken to turn off SCR50. SCR51 and SCR52 provide the same function for

phase B and phase C, respectively. The summation of all of these currents causes the forward reel motor to drive counterclockwise to dump additional tape into the forward vacuum column.

Once relay K50 energizes, another set of its contacts serve a holding function by applying ground through contacts 4C and 4B of Hi Speed relay K1001. This provides continuing drive action even though tape goes below the forward top loop sensor causing switch S1304 to open.

When tape is driven down into the center area of the vacuum column, the forward center loop sensor senses both vacuum and pressure causing switch S1305 to close. The 20 vdc (Enable Reel Motors) then has an easier path to ground through switch S1305, and relay K50 de-energizes. Relay K50 contacts in the SCR circuits open to stop reel drive. The -20 vdc applied through contacts 4C and 4A of Load relay K1 is now applied to the base of transistor Q50 (ground path no longer available through diode CR58) and brakes are applied.

During a High-Speed Rewind operation, Hi Speed relay K1001 energizes. This disables the brakes since -20 vdc is no longer available through K1001 contacts 2C and 2B. The servo then reacts only to S1304 to dump tape into the column as needed. Ground is also removed from J51-5 so that tape is not driven below top sensor during rewind.

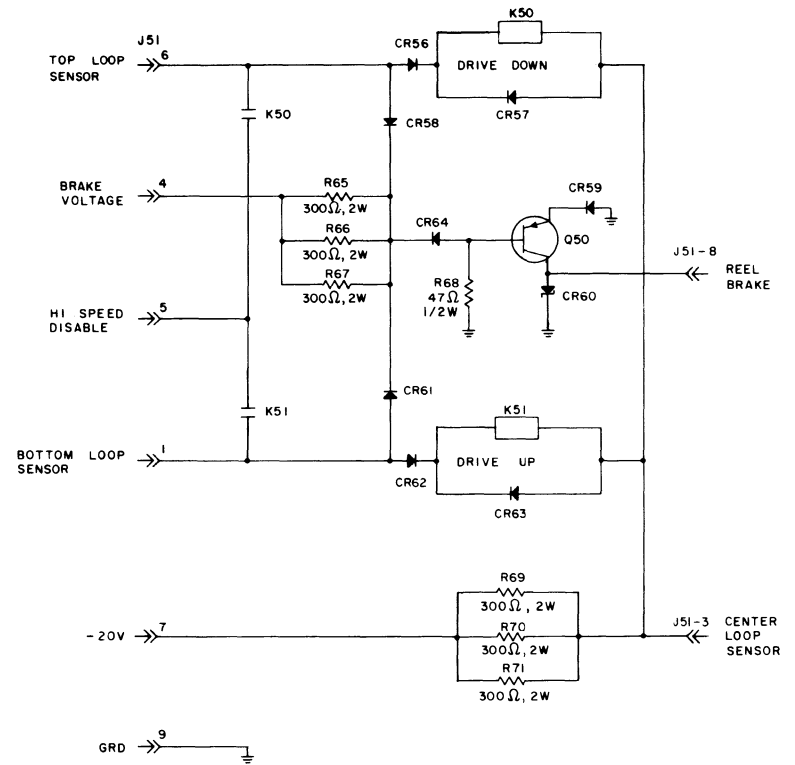
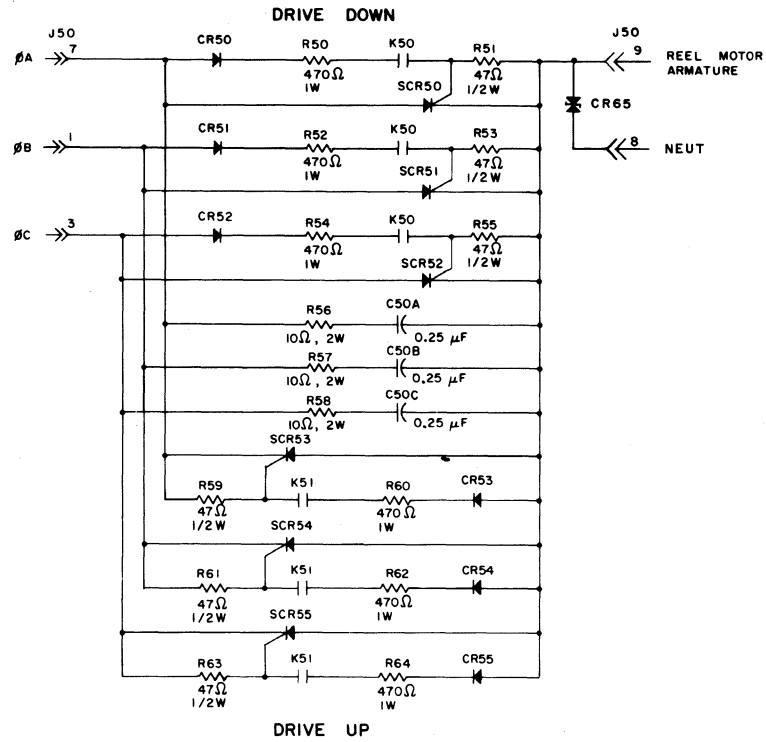

CONTROL DATA		TITLE	PRODUCT
CORPORATION		POWER SUPPLY 3	608
DEVELOPMENT DIVISION		SIZE DRAWING NO	REV
		C 45712100	AG
		SHEET 17	PAGE 1-33

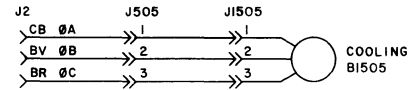
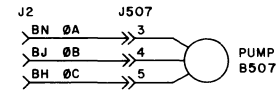
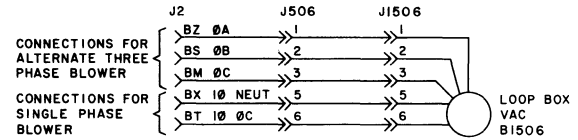
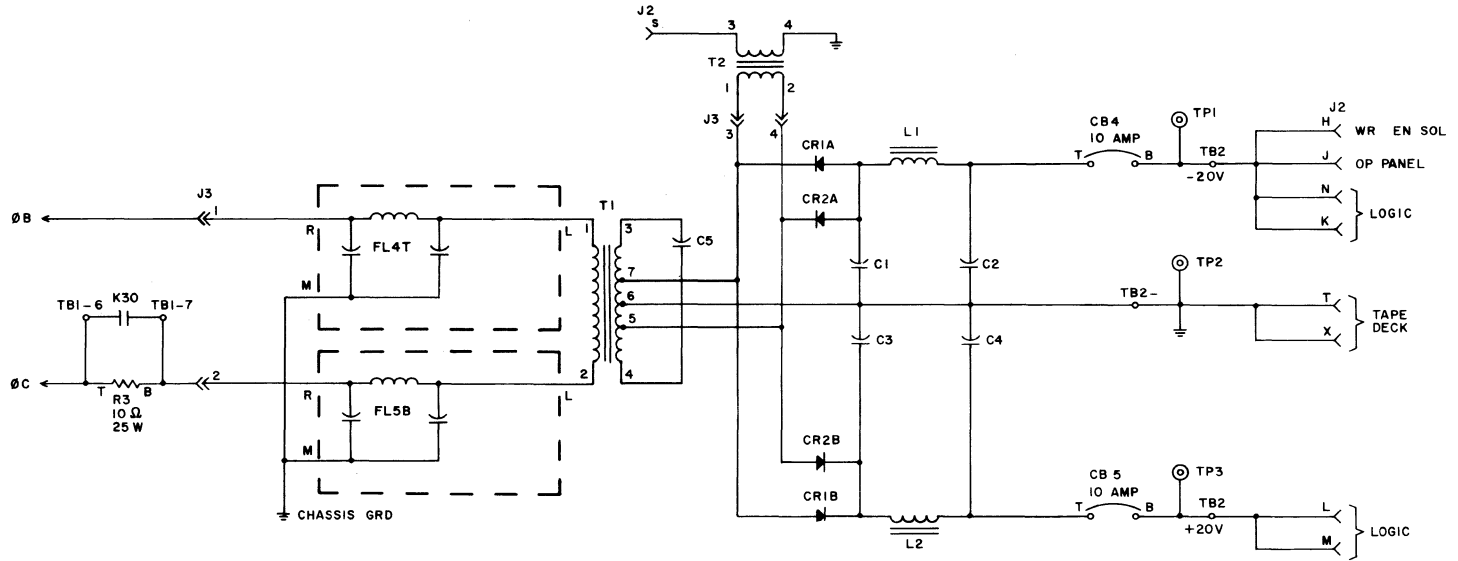

CONTROL DATA CORPORATION	TITLE	PRODUCT
	POWER PANEL & PNEUMATIC PACKAGE	608
DEVELOPMENT DIVISION	SIZE	DRAWING NO.
	C	45712100
	REV.	
	AH	
SHEET	PAGE	
18	1-35	

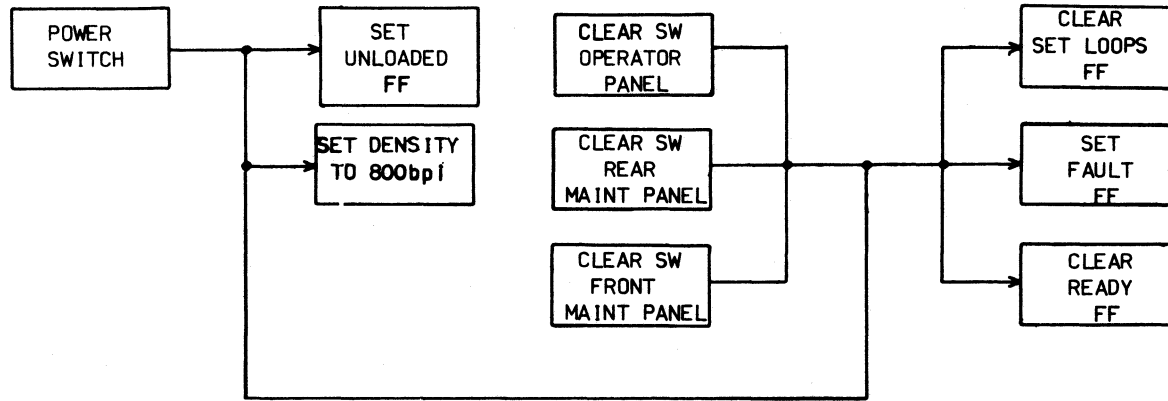

4E6

Power and Manual MC Sequence

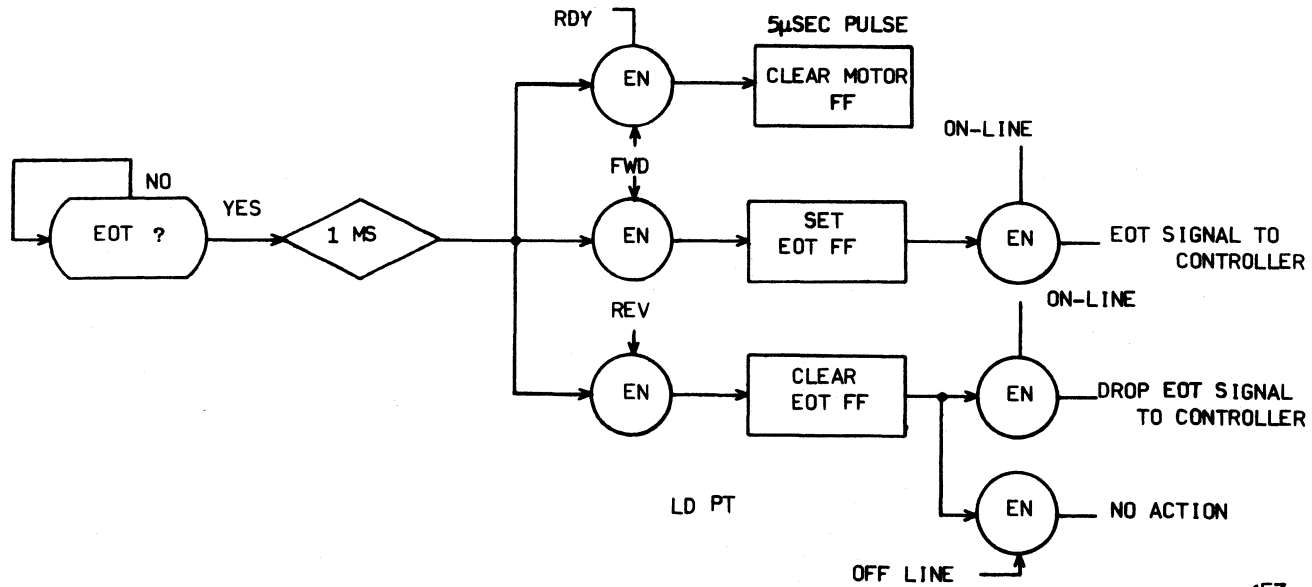

4E7

End of Tape Marker Detection

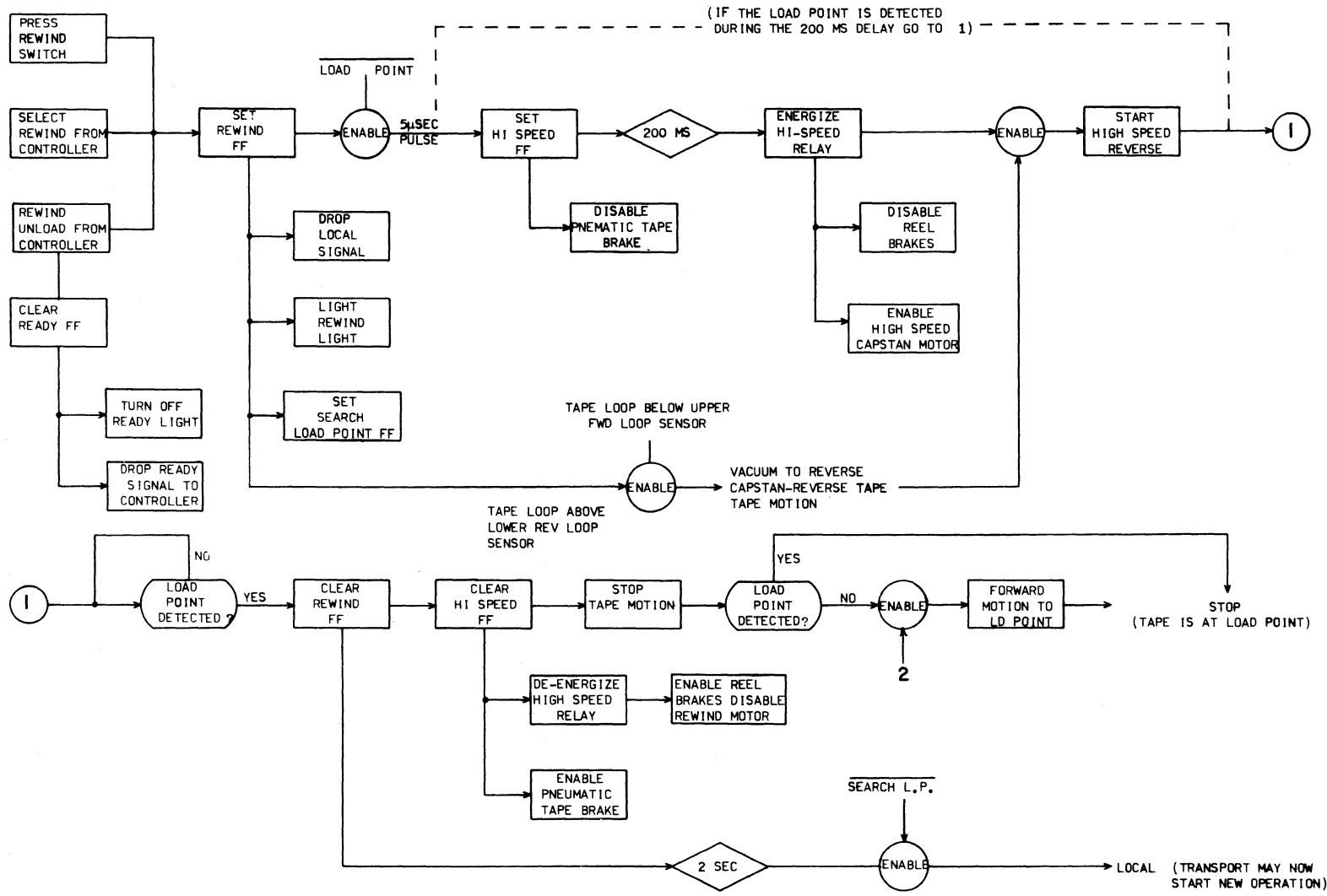

An unload operation may only be performed when the transport is not ready and at load point. Then when the REWIND button is pressed, the Rewind FF is set but the Hi Speed FF is not set. Therefore, tape motion continues at normal reverse speed until all tape is drawn off the forward reel causing a loop fault. The loop fault stops all tape motion and sets the Unloaded FF to de-energize the Load relay.

Rewind Operation

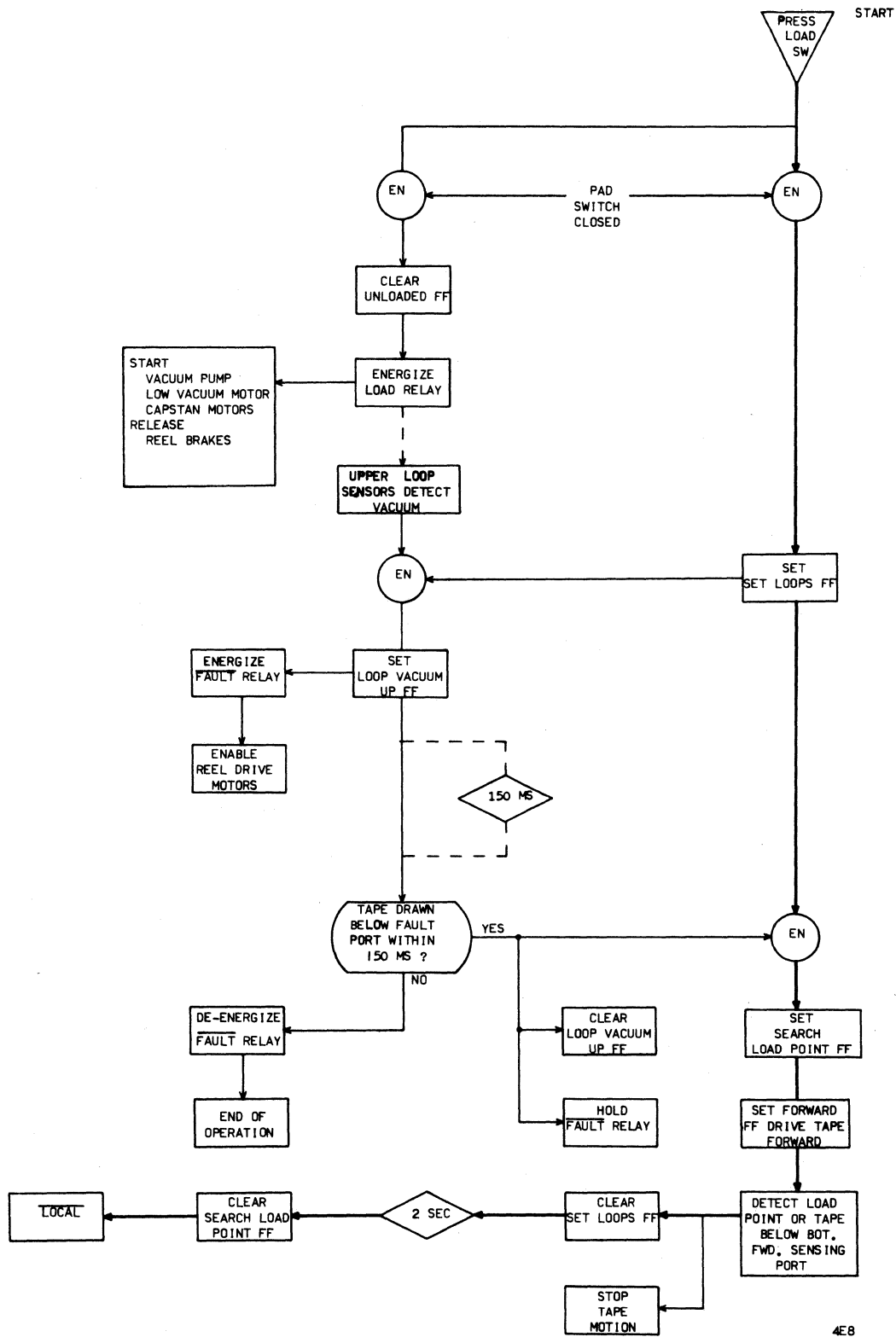

Load Operation Flow Chart

4E8

SECTION 9

WIRE LISTS

DESCRIPTION OF WIRE LISTS

The two types of wire lists are:

1. The line printer format which shows logic wiring.
2. The corporate (typed) form which shows non-logic wiring.

LOGIC WIRE LISTS

The following is an example of the logic wire lists with an identification, and an explanation of the columns.

Wire Identification	Wire Length	Wire Origin Location	Wire Origin Pin Number	Component Code	Wire Destination Location	Wire Destination Pin Number	Twisted Pair	Color Code	Change Order
K10310	06	A18	07	0	B11	04			
K10311	05	B11	04	0	B20	05			
K10312	03	B20	05	0	B22	06			
K10320	04	A18	08	0	A13	11			
600300	2T	J104	33	X	A38	12	20	4	0970
600310	25	J104	34	X	A42	06	20	4	0970
600320	25	J104	35	X	A42	12	20	4	0970
600330	58	J104	36	X	A28	09	20	4	0970
600340	15	J104	37	X	SHIELD		E	S	0970
600350	15	J104	38	X	A02	01	24 E	0	0970

Wire Identification

If the first term in this column begins with a letter, the wire originates at a logic card; the letter and the first three digits represents the logic symbol of that card. If the first term begins with a numeral, the wire originates at a point other than logic, for

example at a switch or resistor. A sequential advance in the second to the last digit indicates additional inputs to the same card.

A sequential advance in the last digit indicates the interconnections of an AND input.

K10310	}	Three input AND to K103
K10311		
K10312		
K10320		Single input OR to K103

Wire Length

This column gives the wire length in inches.

Wire Origin Location

This column locates the origin of the wire on the logic chassis. Wires having a common signal at two or more locations are interconnected in series. In the sample, the first three wires shown have a common signal. The Wire Destination Location of the first wire becomes the Wire Origin Location of the second so that the series string is from A18 to B11 to B20 to B22. Note that the first four characters of the Wire Identification terms are the same for the three wires and that the sequencing is from 10 to 11 to 12 in the last two characters.

Wire Origin Pin Number

This column identifies the origin pin or terminal of the wire.

Component Code

This column identifies the components that are located in the Wire Origin Location column. The code letters are identified as follows:

- 0 - Logic Card
- R - Miscellaneous Component (Switch, Resistor, etc.)
- X - Jack

Wire Destination Location

This column locates the destination of the wire on the logic chassis.

Wire Destination Pin Number

This column identifies the destination pin or terminal of the wire.

Wire Size

This column identifies the size (AWG) of the wire.

Twisted Pair

When two successive wires have the same letter in this column, this identifies them as a twisted pair.

Color Code

Solid colored wires are identified by a one digit number in this column. Multicolored wires are identified by a number having two or three digits. Each digit of the number identifies one of the colors. The code numbers are identified as follows:

0 - Black	2 - Red	4 - Yellow	6 - Blue	8 - Gray	S - Shield
1 - Brown	3 - Orange	5 - Green	7 - Violet	9 - White	

Change Order

This column identifies the engineering, field, or publications change order that affected and/or altered that wire.

NON-LOGIC LISTS

CONTROL DATA		WIRE LISTING								WL	DOCUMENT NO.	REV.
COMPUTER DIVISION		SHEET OF										
CONDUCTOR IDENT.	FIND NO.	GAUGE (REF.)	COLOR (REF.)	LENGTH (APPROX)	ORIGIN		DESTINATION		ACCESS FIND NO.	ACCESS FIND NO.	REMARKS	
20	29	24	993	03	X12	03	X12	09				
21	29	↑	993	03	X13	03	X13	09				
22	29		993	03	X14	03	X14	09				
23	29		993	03	X15	03	X15	09				
24	29		993	03	X16	03	X16	09				

Wire lists other than logic are on a standard corporate form. The remaining columns of the form contain information NOT normally applicable to field usage and therefore are not explained.

The other columns indicate:

- Gauge (Ref) - Size of conductor (AWG)
- Color (Ref) - Color information
- Length (Approx) - Length of conductor in inches
- Origin - Origin point of conductor
- Destination - Destination point of conductor
- Remarks - Useful comments

In multi-digit color codes, the first digit denotes base color and the remaining digits denote tracer colors. The color codes for the non-logic lists are the same as those for logic wiring.

LOGIC CHASSIS

LW45712300 608 TRANSPORT

REVISION N

-01

I00010	04	D12	01	0	D16	03	1604	PLUTO	608
I01010	04	D11	01	0	D16	07	1604	PLUTO	608
I02010	04	D11	04	0	D16	11	1604	PLUTO	608
I03010	04	D11	07	0	D15	03	1604	PLUTO	608
I04010	04	D11	10	0	D15	07	1604	PLUTO	608
I05010	04	D10	01	0	D15	11	1604	PLUTO	608
I06010	04	D10	04	0	D14	03	1604	PLUTO	608
I07010	04	D10	07	0	D14	07	1604	PLUTO	608
I08010	04	D10	10	0	D14	11	1604	PLUTO	608
I09010	04	D13	01	0	C12	12	1604	PLUTO	608
I09110	05	D13	07	0	C12	11	1604	PLUTO	608
I09210	04	C10	01	0	C13	10	1604	PLUTO	608
I09220	03	C10	03	0	C10	14	1604	PLUTO	608
I09221	03	C10	02	0	C10	08	1604	PLUTO	608
I09310	04	C11	01	0	C13	11	1604	PLUTO	608
I09320	04	C11	02	0	C11	14	1604	PLUTO	608
I09410	04	C10	07	0	C13	12	1604	PLUTO	608
I09510	04	C13	07	0	C18	06	1604	PLUTO	608
I09511	05	C18	06	0	C25	03	1604	PLUTO	608
I09512	07	C25	03	0	D17	04	1604	PLUTO	608
I09610	04	D12	04	0	D17	08	1604	PLUTO	608
I09710	09	D12	07	0	C25	05	1604	PLUTO	608
I09712	05	C25	05	0	C31	04	1604	PLUTO	608
I09713	07	C31	04	0	D40	04	1604	PLUTO	608
I10010	05	D34	01	0	D30	12	1604	PLUTO	608
I10011	02	D30	12	0	D31	12	1604	PLUTO	608
I10020	04	D34	02	0	C34	11	1604	PLUTO	608
I10030	02	D34	03	0	D34	04	1604	PLUTO	608
I10040	02	D34	04	0	D34	10	1604	PLUTO	608
I10110	03	D33	07	0	D34	06	1604	PLUTO	608
I10410	07	B38	07	0	C31	06	1604	PLUTO	608
I10510	04	D33	01	0	C33	11	1604	PLUTO	608
I10511	04	C33	11	0	C30	06	1604	PLUTO	608
I10512	05	C30	06	0	C23	09	1604	PLUTO	608
I10610	03	C27	01	0	C28	06	1604	PLUTO	608
I10611	03	C29	06	0	C27	01	1604	PLUTO	608
I10710	03	C25	01	0	C27	04	1604	PLUTO	608
I10810	02	C27	07	0	C27	05	1604	PLUTO	608
I11010	05	C26	07	0	C32	04	1604	PLUTO	608
I11020	05	C26	08	0	C32	08	1604	PLUTO	608
I11110	06	D33	04	0	C26	09	1604	PLUTO	608
I11111	06	C26	09	0	C16	03	1604	PLUTO	608
I11210	03	C25	07	0	C26	12	1604	PLUTO	608
I11310	07	D24	01	0	C27	03	1604	PLUTO	608
I11410	03	C23	01	0	C24	05	1604	PLUTO	608
I11510	02	C23	07	0	C23	06	1604	PLUTO	608
I11511	05	C23	06	0	C16	05	1604	PLUTO	608
I11610	03	B42	01	0	B44	06	1604	PLUTO	608
I11710	04	B39	01	0	B39	14	1604	PLUTO	608

PB5048
PB5048

1423

1314

I11720	04	B39	02	0	B41	11	1604	PLUTO	608	
I11810	02	B39	07	0	B39	06	1604	PLUTO	608	
I11811	12	B39	06	0	C16	05	1604	PLUTO	608	
I11820	03	B39	08	0	B41	12	1604	PLUTO	608	
I11910	05	C36	01	0	B39	03	1604	PLUTO	608	
I12010	03	B42	04	0	B44	12	1604	PLUTO	608	
I12110	04	B38	01	0	B40	12	1604	PLUTO	608	
I12210	03	C38	04	0	C36	02	1604	PLUTO	608	PB5048
I12211	06	C36	02	0	C26	10	1604	PLUTO	608	PB5048
I12212	05	C26	10	0	D23	12	1604	PLUTO	608	PB5048
I12510	03	C36	07	0	C37	11	1604	PLUTO	608	
I12610	06	D25	07	0	C31	11	1604	PLUTO	608	
I12710	10	D24	07	0	C37	04	1604	PLUTO	608	1314
I20110	10	C38	07	0	D18	02	1604	PLUTO	608	
I21110	10	C38	10	0	D18	06	1604	PLUTO	608	
I22010	04	C40	01	0	C37	10	1604	PLUTO	608	
I22110	10	C40	07	0	C19	05	1604	PLUTO	608	
I30110	02	C18	01	0	C19	03	1604	PLUTO	608	
I30210	07	D12	10	0	C19	04	1604	PLUTO	608	
I30410	02	C18	07	0	C19	06	1604	PLUTO	608	
I30510	05	C13	01	0	C19	10	1604	PLUTO	608	
I30610	04	C17	01	0	C19	11	1604	PLUTO	608	
I30710	03	C17	07	0	C19	12	1604	PLUTO	608	
I31010	06	C19	01	0	D19	02	1604	PLUTO	608	
I31011	03	D19	02	0	D24	09	1604	PLUTO	608	PB5048
I31110	05	C19	07	0	D19	03	1604	PLUTO	608	
I31111	03	D19	03	0	D24	10	1604	PLUTO	608	PB5048
I31112	05	D24	10	0	C25	06	1604	PLUTO	608	PB5048
I40010	04	D35	01	0	C36	06	1604	PLUTO	608	
I40011	05	C36	06	0	C29	12	1604	PLUTO	608	
I40020	05	D35	02	0	D43	04	1604	PLUTO	608	
I40021	06	D43	04	0	C36	11	1604	PLUTO	608	
I40022	06	C36	11	0	C27	12	1604	PLUTO	608	
I40030	08	D35	03	0	D19	06	1604	PLUTO	608	
I40031	05	D19	06	0	C17	11	1604	PLUTO	608	
I40110	06	D34	07	0	D43	08	1604	PLUTO	608	
I40111	06	D43	03	0	C36	10	1604	PLUTO	608	
I40120	08	D34	08	0	D19	11	1604	PLUTO	608	
I40121	06	D19	11	0	C17	09	1604	PLUTO	608	
I40130	05	D34	09	0	C37	05	1604	PLUTO	608	PB5048
I40131	04	C37	05	0	C32	11	1604	PLUTO	608	PB5048
I40140	02	D34	10	0	D34	14	1604	PLUTO	608	PB5048
I40210	09	D36	04	0	D19	07	1604	PLUTO	608	
I40310	09	D36	10	0	D19	12	1604	PLUTO	608	
I40410	03	D36	01	0	D35	06	1604	PLUTO	608	
I40411	07	D35	06	0	C26	05	1604	PLUTO	608	1565
I40510	03	D36	07	0	D34	12	1604	PLUTO	608	
I40610	04	D41	01	0	D37	11	1604	PLUTO	608	
I40710	06	D40	01	0	D32	12	1604	PLUTO	608	
I40720	04	D40	02	0	D40	12	1604	PLUTO	608	

I40721	10	D40	12	0	C23	05	1604	PLUTO	608	
I40810	02	D41	05	0	D41	03	1604	PLUTO	608	1423
I40910	03	D41	09	0	D40	06	1604	PLUTO	608	1423
I41010	10	D33	10	0	B38	05	1604	PLUTO	608	
I41011	12	B38	05	0	C16	12	1604	PLUTO	608	
I41110	03	D35	07	0	D33	12	1604	PLUTO	608	
I41111	04	D33	12	0	D37	12	1604	PLUTO	608	
I41112	06	D37	12	0	C36	09	1604	PLUTO	608	
I41113	06	C36	09	0	B38	06	1604	PLUTO	608	
I41120	08	D35	08	0	B38	09	1604	PLUTO	608	
I41130	08	D35	09	0	B39	12	1604	PLUTO	608	
I41210	07	C38	01	0	D35	12	1604	PLUTO	608	
I41211	08	D35	12	0	C23	12	1604	PLUTO	608	
I41212	05	C23	12	0	C16	11	1604	PLUTO	608	
I41310	08	D37	06	0	D25	10	1604	PLUTO	608	1423
I41311	04	D37	06	0	D32	06	1604	PLUTO	608	
I41312	05	D32	06	0	C27	10	1604	PLUTO	608	
I41410	09	B42	07	0	D38	12	1604	PLUTO	608	
I41510	02	B42	10	0	B42	09	1604	PLUTO	608	
I41511	11	B42	09	0	C24	04	1604	PLUTO	608	
I41512	06	C24	04	0	D32	04	1604	PLUTO	608	8193
I41513	06	D32	04	0	D37	04	1604	PLUTO	608	8193
I41610	03	D40	08	0	D43	12	1604	PLUTO	608	
I41620	07	D40	07	0	C34	03	1604	PLUTO	608	
I41710	05	D25	01	0	C22	05	1604	PLUTO	608	
I41711	07	C22	05	0	D32	05	1604	PLUTO	608	
I41712	04	D32	05	0	D37	05	1604	PLUTO	608	
I41810	02	D25	04	0	D25	03	1604	PLUTO	608	
I41910	05	C26	01	0	C33	02	1604	PLUTO	608	1565
I41911	03	C33	02	0	C37	03	1604	PLUTO	608	1565
I41920	04	C26	02	0	C26	14	1604	PLUTO	608	1565
K00010	04	D09	01	0	D09	14	1604	PLUTO	608	
K00020	04	D09	02	0	C09	12	1604	PLUTO	608	
K00021	06	C09	12	0	D16	04	1604	PLUTO	608	
K00110	05	D09	07	0	D13	12	1604	PLUTO	608	
K00120	05	D09	08	0	C09	11	1604	PLUTO	608	
K00121	04	C09	11	0	D12	03	1604	PLUTO	608	
K01010	04	D08	01	0	D08	14	1604	PLUTO	608	
K01020	04	D08	02	0	C08	12	1604	PLUTO	608	
K01021	06	C08	12	0	D16	08	1604	PLUTO	608	
K01110	04	D08	07	0	D13	11	1604	PLUTO	608	
K01120	05	D08	08	0	C08	11	1604	PLUTO	608	
K01121	05	C08	11	0	D11	03	1604	PLUTO	608	
K02010	04	D07	01	0	D07	14	1604	PLUTO	608	
K02020	04	D07	02	0	C07	12	1604	PLUTO	608	
K02021	07	C07	12	0	D16	12	1604	PLUTO	608	
K02110	05	D07	07	0	D13	10	1604	PLUTO	608	
K02120	05	D07	08	0	C07	11	1604	PLUTO	608	
K02121	05	C07	11	0	D11	06	1604	PLUTO	608	
K03010	04	D06	01	0	D06	14	1604	PLUTO	608	

K03020	04	D06	02	0	C06	12	1604	PLUTO	608
K03021	07	C06	12	0	D15	04	1604	PLUTO	608
K03110	05	D06	07	0	D13	09	1604	PLUTO	608
K03120	05	D06	08	0	C06	11	1604	PLUTO	608
K03121	06	C06	11	0	D11	09	1604	PLUTO	608
K04010	04	D05	01	0	D05	14	1604	PLUTO	608
K04020	04	D05	02	0	C05	12	1604	PLUTO	608
K04021	07	C05	12	0	D15	08	1604	PLUTO	608
K04110	05	D05	07	0	D13	06	1604	PLUTO	608
K04120	05	D05	08	0	C05	11	1604	PLUTO	608
K04121	06	C05	11	0	D11	12	1604	PLUTO	608
K05010	04	D04	01	0	D04	14	1604	PLUTO	608
K05020	04	D04	02	0	C04	12	1604	PLUTO	608
K05021	08	C04	12	0	D15	12	1604	PLUTO	608
K05110	06	D04	07	0	D13	05	1604	PLUTO	608
K05120	05	D04	08	0	C04	11	1604	PLUTO	608
K05121	05	C04	11	0	D10	03	1604	PLUTO	608
K06010	04	D03	01	0	D03	14	1604	PLUTO	608
K06020	04	D03	02	0	C03	12	1604	PLUTO	608
K06021	07	C03	12	0	D14	04	1604	PLUTO	608
K06110	06	D03	07	0	D13	04	1604	PLUTO	608
K06120	05	D03	08	0	C03	11	1604	PLUTO	608
K06121	06	C03	11	0	D10	06	1604	PLUTO	608
K07010	04	D02	01	0	D02	14	1604	PLUTO	608
K07020	04	D02	02	0	C02	12	1604	PLUTO	608
K07021	08	C02	12	0	D14	08	1604	PLUTO	608
K07110	07	D02	07	0	D13	03	1604	PLUTO	608
K07120	05	D02	08	0	C02	11	1604	PLUTO	608
K07121	06	C02	11	0	D10	09	1604	PLUTO	608
K08010	04	D01	01	0	D01	14	1604	PLUTO	608
K08020	04	D01	02	0	C01	12	1604	PLUTO	608
K08021	08	C01	12	0	D14	12	1604	PLUTO	608
K08110	07	D01	07	0	D13	02	1604	PLUTO	608
K08120	05	D01	08	0	C01	11	1604	PLUTO	608
K08121	07	C01	11	0	D10	12	1604	PLUTO	608
K09010	04	C12	01	0	C16	01	1604	PLUTO	608
K09011	02	C16	01	0	C16	02	1604	PLUTO	608
K09012	03	C16	02	0	C18	02	1604	PLUTO	608
K09013	06	C18	02	0	D17	07	1604	PLUTO	608
K09014	07	D17	07	0	C25	04	1604	PLUTO	608
K09015	10	C25	04	0	C44	10	1604	PLUTO	608
K09020	02	C12	02	0	C12	03	1604	PLUTO	608
K09021	04	C12	03	0	C12	14	1604	PLUTO	608
K09110	05	C12	07	0	C18	03	1604	PLUTO	608
K09111	07	C18	03	0	D17	12	1604	PLUTO	608
K09120	05	C12	08	0	D12	06	1604	PLUTO	608
K09121	06	D12	06	0	C16	03	1604	PLUTO	608
K09122	03	C16	03	0	C18	04	1604	PLUTO	608
K09123	06	C18	04	0	D19	08	1604	PLUTO	608
K09130	05	C12	09	0	D12	09	1604	PLUTO	608

K10010	05	C31	01	0	C25	12	1604	PLUTO	608
K10020	06	C31	02	0	D34	05	1604	PLUTO	608
K10021	10	D34	05	0	C16	10	1604	PLUTO	608
K10030	06	C31	03	0	C21	12	1604	PLUTO	608
K10110	06	C31	07	0	D33	06	1604	PLUTO	608
K10111	06	D33	06	0	C26	11	1604	PLUTO	608
K10120	03	C31	08	0	C30	11	1604	PLUTO	608
K10121	06	C30	11	0	D33	09	1604	PLUTO	608
K10130	03	C31	09	0	C31	14	1604	PLUTO	608
K10210	03	C30	01	0	C33	03	1604	PLUTO	608
K10211	03	C33	03	0	C33	10	1604	PLUTO	608
K10212	03	C33	10	0	C36	12	1604	PLUTO	608
K10220	02	C30	02	0	C30	03	1604	PLUTO	608
K10221	04	C30	03	0	C30	14	1604	PLUTO	608
K10310	07	C30	07	0	B39	11	1604	PLUTO	608
K10320	04	C30	08	0	C25	11	1604	PLUTO	608
K10330	03	C30	09	0	C33	08	1604	PLUTO	608
K10331	09	C33	08	0	C16	09	1604	PLUTO	608
K10410	04	C29	01	0	C30	12	1604	PLUTO	608
K10411	04	C30	12	0	C34	12	1604	PLUTO	608
K10420	04	C29	02	0	C23	04	1604	PLUTO	608
K10430	03	C29	03	0	C29	14	1604	PLUTO	608
K10510	06	C29	07	0	B38	12	1604	PLUTO	608
K10520	03	C29	08	0	C28	05	1604	PLUTO	608
K10521	07	D41	04	0	C29	08	1604	PLUTO	608
K10530	03	C29	09	0	C32	10	1604	PLUTO	608
K10610	05	C24	01	0	C18	08	1604	PLUTO	608
K10611	05	C18	08	0	D20	04	1604	PLUTO	608
K10612	09	D20	04	0	C36	04	1604	PLUTO	608
K10620	05	C24	02	0	C18	09	1604	PLUTO	608
K10621	05	C18	09	0	D20	07	1604	PLUTO	608
K10622	09	D20	07	0	C36	05	1604	PLUTO	608
K10630	06	C24	03	0	C32	12	1604	PLUTO	608
K10631	04	C32	12	0	C36	08	1604	PLUTO	608
K10632	03	C36	08	0	C38	05	1604	PLUTO	608
K10710	05	C24	07	0	C16	07	1604	PLUTO	608
K10711	11	C16	07	0	B38	11	1604	PLUTO	608
K10720	09	C24	08	0	B39	10	1604	PLUTO	608
K10730	03	C24	09	0	C24	14	1604	PLUTO	608
K10810	03	C22	01	0	C23	02	1604	PLUTO	608
K10811	03	C23	02	0	C23	10	1604	PLUTO	608
K10812	04	C23	10	0	C36	03	1604	PLUTO	608
K10813	09	C36	03	0	C15	02	1604	PLUTO	608
K10910	03	C22	07	0	C24	06	1604	PLUTO	608
K10911	06	C24	06	0	C15	01	1604	PLUTO	608
K11010	03	C21	01	0	C22	04	1604	PLUTO	608
K11011	03	C22	04	0	C23	03	1604	PLUTO	608
K11012	08	C23	03	0	B38	10	1604	PLUTO	608
K11020	06	C21	02	0	C32	03	1604	PLUTO	608
K11110	07	C21	07	0	C33	04	1604	PLUTO	608

1447

PB5048

1423
PB5048
1423

PB5048

8242

K11111	03	C33	04	0	C33	12	1604	PLUTO	608
K11120	03	C21	08	0	C21	14	1604	PLUTO	608
K11210	06	C37	01	0	C44	08	1604	PLUTO	608
K11220	04	C37	02	0	C37	14	1604	PLUTO	608
K11310	07	C37	07	0	C25	10	1604	PLUTO	608
K11320	09	C37	08	0	D20	08	1604	PLUTO	608
K11321	03	D20	08	0	D19	04	1604	PLUTO	608
K11322	05	D19	04	0	C15	07	1604	PLUTO	608
K11410	04	D31	01	0	C30	10	1604	PLUTO	608
K11411	04	C30	10	0	C34	04	1604	PLUTO	608
K11412	03	C34	04	0	C34	08	1604	PLUTO	608
K11413	04	C34	08	0	C16	04	1604	PLUTO	608
K11420	04	D31	02	0	D31	14	1604	PLUTO	608
K11510	07	D31	07	0	C21	11	1604	PLUTO	608
K11520	05	D31	08	0	C34	10	1604	PLUTO	608
K11610	03	B35	01	0	B38	04	1604	PLUTO	608
K11611	10	B38	04	0	D41	07	1604	PLUTO	608
K11620	03	B35	02	0	B35	14	1604	PLUTO	608
K11710	03	B35	07	0	B39	09	1604	PLUTO	608
K11720	03	B35	08	0	B38	03	1604	PLUTO	608
K11721	10	B38	03	0	D41	11	1604	PLUTO	608
K20010	03	C42	01	0	C41	04	1604	PLUTO	608
K20011	02	C41	04	0	C40	05	1604	PLUTO	608
K20020	04	C42	02	0	C41	12	1604	PLUTO	608
K20021	03	C41	12	0	C40	06	1604	PLUTO	608
K20030	03	C42	03	0	C40	11	1604	PLUTO	608
K20031	11	C40	11	0	D18	03	1604	PLUTO	608
K20032	05	D18	03	0	C15	03	1604	PLUTO	608
K20110	03	C42	07	0	C42	14	1604	PLUTO	608
K20120	02	C42	08	0	C41	08	1604	PLUTO	608
K20121	04	C41	08	0	C37	06	1604	PLUTO	608
K20130	03	C42	09	0	C40	12	1604	PLUTO	608
K20131	03	C40	12	0	C38	09	1604	PLUTO	608
K20132	10	C38	09	0	D18	07	1604	PLUTO	608
K20133	06	D18	07	0	C15	04	1604	PLUTO	608
K21010	02	C39	01	0	C40	02	1604	PLUTO	608
K21011	03	C40	02	0	C41	07	1604	PLUTO	608
K21020	02	C39	02	0	C40	03	1604	PLUTO	608
K21021	03	C40	03	0	C41	11	1604	PLUTO	608
K21030	03	C39	03	0	C40	08	1604	PLUTO	608
K21031	12	C40	08	0	C15	05	1604	PLUTO	608
K21032	06	C15	05	0	D18	08	1604	PLUTO	608
K21110	03	C39	07	0	C39	14	1604	PLUTO	608
K21120	03	C39	08	0	C40	04	1604	PLUTO	608
K21121	02	C40	04	0	C41	03	1604	PLUTO	608
K21130	02	C39	09	0	C40	09	1604	PLUTO	608
K21131	03	C40	09	0	C38	12	1604	PLUTO	608
K21132	10	C38	12	0	D18	04	1604	PLUTO	608
K21133	05	D18	04	0	C15	06	1604	PLUTO	608
K40010	02	D37	01	0	D36	02	1604	PLUTO	608

1447

1423

K40011	08	D36	02 0	C23	11	1604 PLUTO 608	1565
K40020	02	D37	02 0	D37	03	1604 PLUTO 608	
K40021	04	D37	03 0	D37	14	1604 PLUTO 608	
K40110	02	D37	07 0	D36	06	1604 PLUTO 608	
K40111	08	D36	06 0	D24	12	1604 PLUTO 608	1314
K40112	03	D24	12 0	D24	05	1604 PLUTO 608	1314
K40120	06	D37	08 0	C38	02	1604 PLUTO 608	
K40130	02	D37	09 0	D36	09	1604 PLUTO 608	
K40210	04	D32	01 0	D36	08	1604 PLUTO 608	
K40211	05	D32	01 0	C30	05	1604 PLUTO 608	PB5048
K40220	02	D32	02 0	D32	03	1604 PLUTO 608	
K40221	04	D32	03 0	D32	14	1604 PLUTO 608	
K40310	04	D32	07 0	D36	03	1604 PLUTO 608	
K40320	04	D32	08 0	D36	12	1604 PLUTO 608	
K40321	08	D36	12 0	D24	11	1604 PLUTO 608	1314
K40322	03	D24	11 0	D24	06	1604 PLUTO 608	1314
K40330	07	D32	09 0	C38	03	1604 PLUTO 608	
L00010	07	D26	01 0	C18	05	1604 PLUTO 608	
L00011	13	C18	05 0	C44	11	1604 PLUTO 608	
L10010	06	D27	01 0	C17	12	1604 PLUTO 608	
L10011	12	C17	12 0	B39	04	1604 PLUTO 608	
L10110	06	D27	05 0	C18	12	1604 PLUTO 608	
L10111	11	C18	12 0	B35	12	1604 PLUTO 608	
L10210	06	D27	09 0	C31	05	1604 PLUTO 608	
L10211	07	C31	05 0	C18	11	1604 PLUTO 608	
L20010	07	D28	01 0	C39	12	1604 PLUTO 608	
L20011	03	C39	12 0	C40	10	1604 PLUTO 608	
L20012	03	C40	10 0	C42	05	1604 PLUTO 608	
L21010	07	D28	05 0	C39	10	1604 PLUTO 608	
L21011	03	C39	10 0	C42	11	1604 PLUTO 608	
L21012	14	C42	11 0	D12	11	1604 PLUTO 608	
L22010	03	D28	09 0	D28	14	1604 PLUTO 608	8242
L40010	06	D26	05 0	C18	10	1604 PLUTO 608	
L40011	12	C18	10 0	B42	12	1604 PLUTO 608	
L50010	15	B12	01 0	D37	10	1604 PLUTO 608	8304
L50110	13	B12	05 0	D32	11	1604 PLUTO 608	8304
Y00010	04	C09	01 0	C10	12	1604 PLUTO 608	
Y00020	03	C09	02 0	C09	08	1604 PLUTO 608	
Y00030	04	C09	03 0	C09	14	1604 PLUTO 608	
Y00040	02	C09	04 0	C09	05	1604 PLUTO 608	
Y00041	02	C09	05 0	C09	07	1604 PLUTO 608	
Y00110	03	C14	07 0	C12	06	1604 PLUTO 608	
Y00210	03	C14	01 0	C12	05	1604 PLUTO 608	
Y00310	05	D44	07 0	C44	12	1604 PLUTO 608	
Y00311	11	C44	12 0	C21	06	1604 PLUTO 608	
Y01010	04	C08	01 0	C10	11	1604 PLUTO 608	
Y01020	03	C08	02 0	C08	08	1604 PLUTO 608	
Y01030	04	C08	03 0	C08	14	1604 PLUTO 608	
Y01040	02	C08	04 0	C08	05	1604 PLUTO 608	
Y01041	02	C08	05 0	C08	07	1604 PLUTO 608	

Y02010	04	C07	01 0	C10	10	1604 PLUTO	608
Y02020	03	C07	02 0	C07	08	1604 PLUTO	608
Y02030	04	C07	03 0	C07	14	1604 PLUTO	608
Y02040	02	C07	04 0	C07	05	1604 PLUTO	608
Y02041	02	C07	05 0	C07	07	1604 PLUTO	608
Y03010	04	C06	01 0	C10	09	1604 PLUTO	608
Y03020	03	C06	02 0	C06	08	1604 PLUTO	608
Y03030	04	C06	03 0	C06	14	1604 PLUTO	608
Y03040	02	C06	04 0	C06	05	1604 PLUTO	608
Y03041	02	C06	05 0	C06	07	1604 PLUTO	608
Y04010	04	C05	01 0	C10	06	1604 PLUTO	608
Y04020	03	C05	02 0	C05	08	1604 PLUTO	608
Y04030	04	C05	03 0	C05	14	1604 PLUTO	608
Y04040	02	C05	04 0	C05	05	1604 PLUTO	608
Y04041	02	C05	05 0	C05	07	1604 PLUTO	608
Y05010	05	C04	01 0	C10	05	1604 PLUTO	608
Y05020	03	C04	02 0	C04	08	1604 PLUTO	608
Y05030	04	C04	03 0	C04	14	1604 PLUTO	608
Y05040	02	C04	04 0	C04	05	1604 PLUTO	608
Y05041	02	C04	05 0	C04	07	1604 PLUTO	608
Y06010	05	C03	01 0	C11	05	1604 PLUTO	608
Y06020	03	C03	02 0	C03	08	1604 PLUTO	608
Y06030	04	C03	03 0	C03	14	1604 PLUTO	608
Y06040	02	C03	04 0	C03	05	1604 PLUTO	608
Y06041	02	C03	05 0	C03	07	1604 PLUTO	608
Y07010	05	C02	01 0	C11	06	1604 PLUTO	608
Y07020	03	C02	02 0	C02	08	1604 PLUTO	608
Y07030	04	C02	03 0	C02	14	1604 PLUTO	608
Y07040	02	C02	04 0	C02	05	1604 PLUTO	608
Y07041	02	C02	05 0	C02	07	1604 PLUTO	608
Y08010	06	C01	01 0	C10	04	1604 PLUTO	608
Y08020	03	C01	02 0	C01	08	1604 PLUTO	608
Y08030	04	C01	03 0	C01	14	1604 PLUTO	608
Y08040	02	C01	04 0	C01	05	1604 PLUTO	608
Y08041	02	C01	05 0	C01	07	1604 PLUTO	608
Y10010	04	C35	01 0	C31	12	1604 PLUTO	608
Y10110	06	C35	07 0	D33	08	1604 PLUTO	608
Y10111	05	D33	08 0	D25	09	1604 PLUTO	608
Y10112	06	D25	09 0	C21	05	1604 PLUTO	608
Y10210	06	C28	01 0	D33	03	1604 PLUTO	608
Y10220	03	C28	09 0	C28	08	1604 PLUTO	608
Y10310	09	B37	01 0	C24	12	1604 PLUTO	608
Y10410	09	B37	07 0	C22	12	1604 PLUTO	608
Y10411	03	C22	12 0	C20	06	1604 PLUTO	608
Y10510	08	B36	07 0	C21	04	1604 PLUTO	608
Y10610	02	B44	02 0	B44	03	1604 PLUTO	608
Y10710	03	B41	01 0	B42	03	1604 PLUTO	608
Y10810	04	B43	01 0	B39	05	1604 PLUTO	608
Y10910	02	B44	08 0	B44	09	1604 PLUTO	608
Y11010	03	B40	01 0	B42	06	1604 PLUTO	608

8495

Y11110	07	B43	07	0	C37	12	1604	PLUTO	608
Y11111	06	C37	12	0	C27	09	1604	PLUTO	608
Y11112	08	C27	09	0	D25	08	1604	PLUTO	608
Y11210	03	D30	01	0	D31	06	1604	PLUTO	608
Y11310	03	C20	01	0	C22	06	1604	PLUTO	608
Y11410	08	D23	01	0	D40	03	1604	PLUTO	608
Y11420	02	D23	04	0	D23	07	1604	PLUTO	608
Y20010	04	C43	01	0	C39	06	1604	PLUTO	608
Y21010	02	C43	07	0	C42	06	1604	PLUTO	608
Y22010	04	D44	01	0	C42	12	1604	PLUTO	608
Y22011	03	C42	12	0	C39	11	1604	PLUTO	608
Y40010	02	D42	01	0	D41	02	1604	PLUTO	608
Y40020	03	D42	04	0	D42	10	1604	PLUTO	608
Y40110	03	D39	01	0	D40	05	1604	PLUTO	608
Y40120	03	D39	04	0	D39	10	1604	PLUTO	608
Y40210	02	D42	07	0	D41	06	1604	PLUTO	608
Y40220	02	D42	10	0	D42	14	1604	PLUTO	608
Y40310	03	D39	07	0	D41	12	1604	PLUTO	608
Y40320	03	D39	10	0	D39	14	1604	PLUTO	608
Y40410	08	D25	11	0	D38	01	1604	PLUTO	608
Y40420	02	D38	04	0	D38	07	1604	PLUTO	608
Y40610	03	D29	01	0	D25	02	1604	PLUTO	608
Y40620	03	D29	04	0	D29	10	1604	PLUTO	608
Y40710	03	D29	07	0	D25	06	1604	PLUTO	608
Y40720	02	D29	10	0	D29	14	1604	PLUTO	608
Y50210	02	A18	01	0	A18	02	1604	PLUTO	608
Y50211	02	A18	02	0	A18	03	1604	PLUTO	608
Y50220	02	A18	04	0	A18	05	1604	PLUTO	608
Y50221	02	A18	05	0	A17	06	1604	PLUTO	608
Y50230	03	A18	08	0	A17	12	1604	PLUTO	608
Y50310	06	B09	01	0	A18	12	1604	PLUTO	608
Y50311	07	A18	12	0	C17	06	1604	PLUTO	608
Y50320	03	B09	02	0	B09	08	1604	PLUTO	608
Y50321	04	B09	08	0	E11	02	1604	PLUTO	608
Y50330	02	B09	04	0	B09	05	1604	PLUTO	608
Y50331	02	B09	05	0	B09	07	1604	PLUTO	608
Y50410	03	B11	01	0	E12	07	1604	PLUTO	608
Y51210	02	A16	01	0	A16	02	1604	PLUTO	608
Y51211	02	A16	02	0	A16	03	1604	PLUTO	608
Y51220	02	A16	04	0	A16	05	1604	PLUTO	608
Y51221	02	A16	05	0	A15	06	1604	PLUTO	608
Y51230	03	A16	08	0	A15	12	1604	PLUTO	608
Y51310	06	B08	01	0	A16	12	1604	PLUTO	608
Y51311	07	A16	12	0	C17	05	1604	PLUTO	608
Y51320	03	B08	02	0	B08	08	1604	PLUTO	608
Y51321	03	B08	08	0	E11	04	1604	PLUTO	608
Y51330	02	B08	04	0	B08	05	1604	PLUTO	608
Y51331	02	B08	05	0	B08	07	1604	PLUTO	608
Y51410	02	B11	03	0	E11	01	1604	PLUTO	608
Y52210	02	A14	01	0	A14	02	1604	PLUTO	608

PB5048
PB5048
8304

1423

Y52211	02	A14	02	0	A14	03	1604	PLUTO	608
Y52220	02	A14	04	0	A14	05	1604	PLUTO	608
Y52221	02	A14	05	0	A13	06	1604	PLUTO	608
Y52230	03	A14	08	0	A13	12	1604	PLUTO	608
Y52310	02	B07	01	0	A14	12	1604	PLUTO	608
Y52311	07	A14	12	0	C17	04	1604	PLUTO	608
Y52320	03	B07	02	0	B07	08	1604	PLUTO	608
Y52321	04	B07	08	0	B11	06	1604	PLUTO	608
Y52330	02	B07	04	0	B07	05	1604	PLUTO	608
Y52331	02	B07	05	0	B07	07	1604	PLUTO	608
Y52410	02	B11	05	0	B11	03	1604	PLUTO	608
Y53210	02	A12	01	0	A12	02	1604	PLUTO	608
Y53211	02	A12	02	0	A12	03	1604	PLUTO	608
Y53220	02	A12	04	0	A12	05	1604	PLUTO	608
Y53221	02	A12	05	0	A11	06	1604	PLUTO	608
Y53230	02	A12	08	0	A11	12	1604	PLUTO	608
Y53310	05	B06	01	0	A12	12	1604	PLUTO	608
Y53311	08	A12	12	0	C17	03	1604	PLUTO	608
Y53320	03	B06	02	0	B06	08	1604	PLUTO	608
Y53321	04	B06	08	0	B11	08	1604	PLUTO	608
Y53330	02	B06	04	0	B06	05	1604	PLUTO	608
Y53331	02	B06	05	0	B06	07	1604	PLUTO	608
Y53410	02	B11	07	0	B11	05	1604	PLUTO	608
Y54210	02	A10	01	0	A10	02	1604	PLUTO	608
Y54211	02	A10	02	0	A10	03	1604	PLUTO	608
Y54220	02	A10	04	0	A10	05	1604	PLUTO	608
Y54221	02	A10	05	0	AC9	06	1604	PLUTO	608
Y54230	03	A10	08	0	A09	12	1604	PLUTO	608
Y54310	05	B05	01	0	A10	12	1604	PLUTO	608
Y54311	08	A10	12	0	C13	06	1604	PLUTO	608
Y54320	03	B05	02	0	B05	08	1604	PLUTO	608
Y54321	04	B05	08	0	B11	10	1604	PLUTO	608
Y54330	02	B05	04	0	B05	05	1604	PLUTO	608
Y54331	02	B05	05	0	B05	07	1604	PLUTO	608
Y54410	02	B11	09	0	B11	07	1604	PLUTO	608
Y55210	02	A08	01	0	A08	02	1604	PLUTO	608
Y55211	02	A08	02	0	A08	03	1604	PLUTO	608
Y55220	02	A08	04	0	A08	05	1604	PLUTO	608
Y55221	02	A08	05	0	A07	06	1604	PLUTO	608
Y55230	03	A08	08	0	A07	12	1604	PLUTO	608
Y55310	04	B04	01	0	A08	12	1604	PLUTO	608
Y55311	08	A08	12	0	C13	05	1604	PLUTO	608
Y55320	03	B04	02	0	B04	08	1604	PLUTO	608
Y55321	05	B04	08	0	B11	11	1604	PLUTO	608
Y55330	02	B04	04	0	B04	05	1604	PLUTO	608
Y55331	02	B04	05	0	B04	07	1604	PLUTO	608
Y56210	02	A06	01	0	A06	02	1604	PLUTO	608
Y56211	02	A06	02	0	A06	03	1604	PLUTO	608
Y56220	02	A06	04	0	A06	05	1604	PLUTO	608
Y56221	02	A06	05	0	A05	06	1604	PLUTO	608

Y56230	03	A06	08	0	A05	12	1604	PLUTO	608
Y56310	04	B03	01	0	A06	12	1604	PLUTO	608
Y56311	08	A06	12	0	C13	04	1604	PLUTO	608
Y56320	03	B03	02	0	B03	08	1604	PLUTO	608
Y56321	05	B03	08	0	B11	12	1604	PLUTO	608
Y56330	02	B03	04	0	B03	05	1604	PLUTO	608
Y56331	02	B03	05	0	B03	07	1604	PLUTO	608
Y57210	02	A04	01	0	A04	02	1604	PLUTO	608
Y57211	02	A04	02	0	A04	03	1604	PLUTO	608
Y57220	02	A04	04	0	A04	05	1604	PLUTO	608
Y57221	02	A04	05	0	A03	06	1604	PLUTO	608
Y57230	03	A04	08	0	A03	12	1604	PLUTO	608
Y57310	04	B02	01	0	A04	12	1604	PLUTO	608
Y57311	08	A04	12	0	C13	03	1604	PLUTO	608
Y57320	03	B02	02	0	B02	08	1604	PLUTO	608
Y57321	05	B02	03	0	B10	02	1604	PLUTO	608
Y57330	02	B02	04	0	B02	05	1604	PLUTO	608
Y57331	02	B02	05	0	B02	07	1604	PLUTO	608
Y57410	03	B10	01	0	B11	09	1604	PLUTO	608
Y58110	03	A01	07	0	A03	07	1604	PLUTO	608
Y58111	03	A03	07	0	A05	07	1604	PLUTO	608
Y58112	03	A05	07	0	A07	07	1604	PLUTO	608
Y58113	03	A07	07	0	A09	07	1604	PLUTO	608
Y58114	03	A09	07	0	A11	07	1604	PLUTO	608
Y58115	03	A11	07	0	A13	07	1604	PLUTO	608
Y58116	03	A13	07	0	A15	07	1604	PLUTO	608
Y58117	03	A15	07	0	A17	07	1604	PLUTO	608
Y58120	03	A01	08	0	A07	08	1604	PLUTO	608
Y58121	04	A07	08	0	A09	08	1604	PLUTO	608
Y58122	03	A09	08	0	A11	08	1604	PLUTO	608
Y58123	03	A11	08	0	A13	08	1604	PLUTO	608
Y58124	03	A13	08	0	A15	08	1604	PLUTO	608
Y58125	03	A15	08	0	A17	08	1604	PLUTO	608
Y58126	08	A17	08	0	C14	06	1604	PLUTO	608
Y58210	02	A02	01	0	A02	02	1604	PLUTO	608
Y58211	02	A02	02	0	A02	03	1604	PLUTO	608
Y58220	02	A02	04	0	A02	05	1604	PLUTO	608
Y58221	02	A02	05	0	A01	06	1604	PLUTO	608
Y58230	03	A02	08	0	A01	12	1604	PLUTO	608
Y58310	03	B01	01	0	A02	12	1604	PLUTO	608
Y58311	09	A02	12	0	C13	02	1604	PLUTO	608
Y58320	03	B01	02	0	B01	08	1604	PLUTO	608
Y58321	05	B01	03	0	B10	04	1604	PLUTO	608
Y58330	02	B01	03	0	B02	03	1604	PLUTO	608
Y58331	02	B02	03	0	B03	03	1604	PLUTO	608
Y58332	02	B03	03	0	B04	03	1604	PLUTO	608
Y58333	02	B04	03	0	B05	03	1604	PLUTO	608
Y58334	02	B05	03	0	B06	03	1604	PLUTO	608
Y58335	02	B06	03	0	B07	03	1604	PLUTO	608
Y58336	02	B07	03	0	B08	03	1604	PLUTO	608

Y58337	02	B08	03	O	B09	03	1604	PLUTO	608			
Y58338	03	B09	03	O	B12	03	1604	PLUTO	608			
Y58340	02	B01	04	O	B01	05	1604	PLUTO	608			
Y58341	02	B01	05	O	B01	07	1604	PLUTO	608			
Y58410	02	B10	03	O	B10	01	1604	PLUTO	608			
100010	10	J201A	A	X	D16	01	1604	PLUTO	608	24	4	8193
100011	10	J201B	A	X	D16	01	1604	PLUTO	608	24	4	8193
100110	10	J201A	B	X	D16	05	1604	PLUTO	608	24	4	8193
100111	10	J201B	B	X	D16	05	1604	PLUTO	608	24	4	8193
100210	10	J201A	C	X	D16	09	1604	PLUTO	608	24	4	8193
100211	10	J201B	C	X	D16	09	1604	PLUTO	608	24	4	8193
100310	10	J201A	D	X	D15	01	1604	PLUTO	608	24	4	8193
100311	10	J201B	D	X	D15	01	1604	PLUTO	608	24	4	8193
100410	10	J201A	E	X	D15	05	1604	PLUTO	608	24	4	8193
100411	10	J201B	E	X	D15	05	1604	PLUTO	608	24	4	8193
100510	10	J201A	F	X	D15	09	1604	PLUTO	608	24	4	8193
100511	10	J201B	F	X	D15	09	1604	PLUTO	608	24	4	8193
100610	10	J201A	H	X	D14	09	1604	PLUTO	608	24	4	8193
100611	10	J201B	H	X	D14	09	1604	PLUTO	608	24	4	8193
100710	10	J201A	J	X	D17	01	1604	PLUTO	608	24	4	8193
100711	10	J201B	J	X	D17	01	1604	PLUTO	608	24	4	8193
100310	10	J201A	K	X	D17	05	1604	PLUTO	608	24	4	8193
100811	10	J201B	K	X	D17	05	1604	PLUTO	608	24	4	8193
100910	09	J201A	L	X	D19	05	1604	PLUTO	608	24	4	8193
100911	09	J201B	L	X	D19	05	1604	PLUTO	608	24	4	8193
101010	09	J201A	M	X	D19	09	1604	PLUTO	608	24	4	8193
101011	09	J201B	M	X	D19	09	1604	PLUTO	608	24	4	8193
101110	10	J201A	N	X	D20	01	1604	PLUTO	608	24	4	8193
101111	10	J201B	N	X	D20	01	1604	PLUTO	608	24	4	8193
101210	09	J201A	P	X	D20	05	1604	PLUTO	608	24	4	8193
101211	09	J201B	P	X	D20	05	1604	PLUTO	608	24	4	8193
101310	10	J201A	R	X	D18	05	1604	PLUTO	608	24	4	8193
101311	10	J201B	R	X	D18	05	1604	PLUTO	608	24	4	8193
101410	10	J201A	S	X	D18	01	1604	PLUTO	608	24	4	8193
101411	10	J201B	S	X	D18	01	1604	PLUTO	608	24	4	8193
101510	06	J201A	T	X	D26	07	1604	PLUTO	608	24	4	8193
101511	07	J201B	T	X	D26	07	1604	PLUTO	608	24	4	8193
101610	04	J201A	U	X	J201B	0U	1604	PLUTO	608	24	4	8193
101710	04	J201A	V	X	J201B	0V	1604	PLUTO	608	24	4	8193
101810	04	J201A	W	X	J201B	0W	1604	PLUTO	608	24	4	8193
101910	10	J201A	X	X	D17	09	1604	PLUTO	608	24	4	8193
101911	10	J201B	X	X	D17	09	1604	PLUTO	608	24	4	8193
102010	06	J201A	Y	X	D28	11	1604	PLUTO	608	24	4	8193
102011	07	J201B	Y	X	D28	11	1604	PLUTO	608	24	4	8193
102110	10	J201A	Z	X	D14	01	1604	PLUTO	608	24	4	8193
102111	10	J201B	Z	X	D14	01	1604	PLUTO	608	24	4	8193
102210	10	J201A	1A	X	D14	05	1604	PLUTO	608	24	4	8193
102211	10	J201B	1A	X	D14	05	1604	PLUTO	608	24	4	8193
102310	06	J201A	1B	X	D27	14	1604	PLUTO	608	24	4	8193
102311	06	J201B	1B	X	D30	14	1604	PLUTO	608	24	4	8193

102410	18	J202A	A X	B09	11	1604	PLUTO	608	24	4	8193
102411	18	J202B	A X	B09	11	1604	PLUTO	608	24	4	8193
102510	18	J202A	B X	B08	11	1604	PLUTO	608	24	4	8193
102511	18	J202B	B X	B08	11	1604	PLUTO	608	24	4	8193
102610	19	J202A	C X	B07	11	1604	PLUTO	608	24	4	8193
102611	19	J202B	C X	B07	11	1604	PLUTO	608	24	4	8193
102710	19	J202A	D X	B06	11	1604	PLUTO	608	24	4	8193
102711	19	J202B	D X	B06	11	1604	PLUTO	608	24	4	8193
102810	20	J202A	E X	B05	11	1604	PLUTO	608	24	4	8193
102811	20	J202B	E X	B05	11	1604	PLUTO	608	24	4	8193
102910	20	J202A	F X	B04	11	1604	PLUTO	608	24	4	8193
102911	20	J202B	F X	B04	11	1604	PLUTO	608	24	4	8193
103010	21	J202A	H X	B01	11	1604	PLUTO	608	24	4	8193
103011	21	J202B	H X	B01	11	1604	PLUTO	608	24	4	8193
103110	10	J202A	J X	D27	11	1604	PLUTO	608	24	4	8193
103111	10	J202B	J X	D27	11	1604	PLUTO	608	24	4	8193
103210	10	J202A	K X	D27	07	1604	PLUTO	608	24	4	8193
103211	10	J202B	K X	D27	07	1604	PLUTO	608	24	4	8193
103310	10	J202A	L X	D27	03	1604	PLUTO	608	24	4	8193
103311	10	J202B	L X	D27	03	1604	PLUTO	608	24	4	8193
103410	10	J202A	M X	D26	03	1604	PLUTO	608	24	4	8193
103411	10	J202B	M X	D26	03	1604	PLUTO	608	24	4	8193
103510	09	J202A	N X	D28	03	1604	PLUTO	608	24	4	8193
103511	09	J202B	N X	D28	03	1604	PLUTO	608	24	4	8193
103610	09	J202A	P X	D28	07	1604	PLUTO	608	24	4	8193
103611	09	J202B	P X	D28	07	1604	PLUTO	608	24	4	8193
103710	14	J202A	R X	J204	OR	1604	PLUTO	608	24	4	8193
103711	14	J202B	R X	J204	OR	1604	PLUTO	608	24	4	8193
103810	14	J202A	S X	J204	OS	1604	PLUTO	608	24	4	8193
103811	14	J202B	S X	J204	OS	1604	PLUTO	608	24	4	8193
103910	14	J202A	T X	J204	OT	1604	PLUTO	608	24	4	8193
103911	14	J202B	T X	J204	OT	1604	PLUTO	608	24	4	8193
104010	14	J202A	U X	J204	BK	1604	PLUTO	608	24	4	8193
104011	14	J202B	U X	J204	BK	1604	PLUTO	608	24	4	8193
104110	14	J202A	V X	J204	BL	1604	PLUTO	608	24	4	8193
104111	14	J202B	V X	J204	BL	1604	PLUTO	608	24	4	8193
104210	14	J202A	W X	J204	BM	1604	PLUTO	608	24	4	8193
104211	14	J202B	W X	J204	BM	1604	PLUTO	608	24	4	8193
104310	14	J202A	X X	J204	BN	1604	PLUTO	608	24	4	8193
104311	14	J202B	X X	J204	BN	1604	PLUTO	608	24	4	8193
104410	14	J202A	Y X	J204	BP	1604	PLUTO	608	24	4	8193
104411	14	J202B	Y X	J204	BP	1604	PLUTO	608	24	4	8193
104510	20	J202A	Z X	B03	11	1604	PLUTO	608	24	4	8193
104511	20	J202B	Z X	B03	11	1604	PLUTO	608	24	4	8193
104610	20	J202A	1A X	B02	11	1604	PLUTO	608	24	4	8193
104611	20	J202B	1A X	B02	11	1604	PLUTO	608	24	4	8193
104710	05	J202A	1B X	D38	14	1604	PLUTO	608	24	4	8193
104711	05	J202B	1B X	D40	14	1604	PLUTO	608	24	4	8193
200010	10	J204	A X	D44	12	1604	PLUTO	608	24	4	8193
200110	19	J204	B X	TE200	14	1604	PLUTO	608	24	4	8193

200210	10	J204	C X	D44	12	1604	PLUTO	608	24	4	8193
200310	11	J204	D X	C33	01	1604	PLUTO	608	24	4	8193
200410	07	J204	E X	B43	06	1604	PLUTO	608	24	4	8193
200510	11	J204	F X	C32	05	1604	PLUTO	608	24	4	8193
200610	10	J204	H X	C35	06	1604	PLUTO	608	24	4	8193
200710	11	J204	J X	C32	09	1604	PLUTO	608	24	4	8193
200810	09	J204	K X	B37	06	1604	PLUTO	608	24	4	8193
200910	07	J204	L X	C44	05	1604	PLUTO	608	24	4	8193
201010	07	J204	M X	E43	12	1604	PLUTO	608	24	4	8193
201110	06	J204	N X	B44	14	1604	PLUTO	608	24	4	8193
201210	17	J204	P X	D19	01	1604	PLUTO	608	24	4	8193
201310	09	J204	U X	B36	12	1604	PLUTO	608	24	4	8193
201410	10	J204	V X	C35	12	1604	PLUTO	608	24	4	8193
201510	09	J204	W X	B37	12	1604	PLUTO	608	24	4	8193
201610	11	J204	X X	C33	09	1604	PLUTO	608	24	4	8193
201710	07	J204	1A X	C43	06	1604	PLUTO	608	24	4	8193
201810	07	J204	1B X	C41	01	1604	PLUTO	608	24	4	8193
201910	07	J204	1C X	B44	07	1604	PLUTO	608	20A	2	8193
202010	07	J204	1D X	B44	08	1604	PLUTO	608	20A	0	8193
202110	07	J204	1E X	B44	09	1604	PLUTO	608	A	S	8193
202210	07	J204	1G X	C43	12	1604	PLUTO	608	24	4	8193
202310	08	J204	1H X	C41	05	1604	PLUTO	608	24	4	8193
202410	07	J204	1I X	B44	01	1604	PLUTO	608	20B	2	8193
202510	07	J204	1J X	E44	02	1604	PLUTO	608	20B	0	8193
202610	07	J204	1K X	E44	03	1604	PLUTO	608	B	S	8193
203010	07	J204	1Q X	C34	09	1604	PLUTO	608	24	4	8193
203110	10	J204	1R X	D42	12	1604	PLUTO	608	20	4	8193
203210	10	J204	1S X	D42	06	1604	PLUTO	608	20	4	8193
203310	11	J204	1T X	D39	12	1604	PLUTO	608	20	4	8193
203410	11	J204	1U X	D39	06	1604	PLUTO	608	20	4	8193
203510	10	J204	1V X	C34	01	1604	PLUTO	608	24	4	8193
203610	10	J204	1W X	C34	05	1604	PLUTO	608	24	4	8193
203710	09	J204	1X X	D43	09	1604	PLUTO	608	24	4	8193
203810	11	J204	1Y X	C33	05	1604	PLUTO	608	24	4	8193
203910	09	J204	1Z X	C200	POS	1604	PLUTO	608	16	2	8193
204010	14	J204	AA X	D29	12	1604	PLUTO	608	20	4	8193
204110	14	J204	AB X	D29	06	1604	PLUTO	608	20	4	8193
204310	11	J204	AD X	C32	01	1604	PLUTO	608	24	4	8193
204410	15	J204	AF X	C201	NEG	1604	PLUTO	608	16	6	8193
204510	15	J204	AH X	C201	NEG	1604	PLUTO	608	16	6	8193
204610	12	J204	AJ X	C200	POS	1604	PLUTO	608	16	2	8193
204710	09	J204	AK X	D44	06	1604	PLUTO	608	24	4	8193
204810	08	J204	AL X	C41	09	1604	PLUTO	608	24	4	8193
300010	16	TB200	01 R	C32	01	1604	PLUTO	608	24	4	8193
300110	19	TB200	02 R	C41	09	1604	PLUTO	608	24	4	8193
300210	11	TB200	03 R	C20	07	1604	PLUTO	608	24	4	8193
300310	13	TB200	04 R	C28	07	1604	PLUTO	608	24	4	8193
300410	12	TB200	19 R	D30	07	1604	PLUTO	608	24	4	8193
300510	18	TB200	06 R	E41	07	1604	PLUTO	608	24	4	8193
300610	18	TB200	07 R	E40	07	1604	PLUTO	608	24	4	8193

300710	22	TB200	08	R	S201	03	1604	PLUTO	608	24	4	8495
300711	22	TB200	08	R	S201	04	1604	PLUTO	608	24	4	8495
300810	22	TB200	09	R	S203	03	1604	PLUTO	608	24	4	8193
300811	22	TB200	09	R	S203	04	1604	PLUTO	608	24	4	8193
300910	04	TB200	10	R	D10	13	1604	PLUTO	608	20	6	8193
301010	23	TB200	11	R	S200	0C	1604	PLUTO	608	24	4	8193
301210	15	TB200	13	R	C44	09	1604	PLUTO	608	24	4	8193
301310	05	TB200	15	R	D21	15	1604	PLUTO	608	20	2	8304
301410	08	TB200	16	R	C14	12	1604	PLUTO	608	24	4	8193
400010	17	J203	A	X	A17	01	1604	PLUTO	608	24A	0	8193
400110	17	J203	B	X	A17	02	1604	PLUTO	608	24A	4	8193
400210	18	J203	E	X	A15	01	1604	PLUTO	608	24B	0	8193
400310	18	J203	F	X	A15	02	1604	PLUTO	608	24B	4	8193
400410	19	J203	K	X	A13	01	1604	PLUTO	608	24C	0	8193
400510	19	J203	L	X	A13	02	1604	PLUTO	608	24C	4	8193
400610	20	J203	P	X	A11	01	1604	PLUTO	608	24D	0	8193
400710	20	J203	R	X	A11	02	1604	PLUTO	608	24D	4	8193
400810	18	J203	S	X	A17	15	1604	PLUTO	608	16	2	8193
400910	20	J203	U	X	A09	01	1604	PLUTO	608	24E	0	8193
401010	20	J203	V	X	A09	02	1604	PLUTO	608	24E	4	8193
401110	18	J203	W	X	A17	14	1604	PLUTO	608	16	0	8193
401210	21	J203	Y	X	A07	01	1604	PLUTO	608	24F	0	8193
401310	21	J203	Z	X	A07	02	1604	PLUTO	608	24F	4	8193
401410	18	J203	AA	X	A17	13	1604	PLUTO	608	16	6	8193
401510	22	J203	CC	X	A05	01	1604	PLUTO	608	24G	0	8193
401610	22	J203	DD	X	A05	02	1604	PLUTO	608	24G	4	8193
401620	29	J203	EE	X	TB200	12	1604	PLUTO	608	24	4	8193
401710	23	J203	HH	X	A03	01	1604	PLUTO	608	24H	0	8193
401810	23	J203	JJ	X	A03	02	1604	PLUTO	608	24H	4	8193
401910	24	J203	MM	X	A01	01	1604	PLUTO	608	24I	0	8193
402010	24	J203	NN	X	A01	02	1604	PLUTO	608	24I	4	8193
402110	91	J1700	1	X	D09	12	1604	PLUTO	608	24A	0	1287
402210	91	J1700	2	X	D09	06	1604	PLUTO	608	24A	4	1287
402310	91	J1700	4	X	D08	12	1604	PLUTO	608	24B	0	1287
402410	91	J1700	6	X	D08	06	1604	PLUTO	608	24B	4	1287
402510	90	J1700	7	X	D07	12	1604	PLUTO	608	24C	0	1287
402610	90	J1700	9	X	D07	06	1604	PLUTO	608	24C	4	1287
402710	90	J1700	10	X	D06	12	1604	PLUTO	608	24D	0	1287
402810	90	J1700	12	X	D06	06	1604	PLUTO	608	24D	4	1287
402910	90	J1700	13	X	D05	12	1604	PLUTO	608	24E	0	1287
403010	90	J1700	15	X	D05	06	1604	PLUTO	608	24E	4	1287
403110	89	J1700	24	X	D04	12	1604	PLUTO	608	24F	0	1287
403210	89	J1700	26	X	D04	06	1604	PLUTO	608	24F	4	1287
403310	89	J1700	27	X	D03	12	1604	PLUTO	608	24G	0	1287
403410	89	J1700	29	X	D03	06	1604	PLUTO	608	24G	4	1287
403510	89	J1700	30	X	D02	12	1604	PLUTO	608	24H	0	1287
403610	89	J1700	32	X	D02	06	1604	PLUTO	608	24H	4	1287
403710	89	J1700	33	X	D01	12	1604	PLUTO	608	24J	0	1287
403810	89	J1700	35	X	D01	06	1604	PLUTO	608	24J	4	1287
403910	95	J1700	20	X	TB200	17	1604	PLUTO	608	20	4	1287

404010	95	J1700	34	X	TB200	18	1604	PLUTO	608	20	4	1287
404020	06	J1700SHD		X	D12	GND	1604	PLUTO	608	24	0	1380
404110	18	S202	01	R	C32	05	1604	PLUTO	608	24	980	8827
404210	14	S201	02	R	A44	14	1604	PLUTO	608	24	940	8827
404310	14	S202	03	R	A43	14	1604	PLUTO	608	24	940	8827
404410	14	S203	02	R	A42	14	1604	PLUTO	608	24	940	8827
404510	16	D43	01	R	S201	01	1604	PLUTO	608	24	960	8827
404610	15	D43	05	R	S203	01	1604	PLUTO	608	24	950	8827
404710	18	A17	07	R	S200	A5	1604	PLUTO	608	24	4	8193
500000	28	A44	15	R	C200	POS	1604	PLUTO	608	20	2	8193
500001	21	A18	15	R	C200	POS	1604	PLUTO	608	20	2	8193
500002	12	A01	15	R	C200	POS	1604	PLUTO	608	20	2	8193
500003	25	B44	15	R	C200	POS	1604	PLUTO	608	20	2	8193
500004	22	B12	15	R	C200	POS	1604	PLUTO	608	20	2	8193
500005	07	B01	15	R	C200	POS	1604	PLUTO	608	20	2	8193
500006	22	C44	15	R	C200	POS	1604	PLUTO	608	20	2	8193
500007	15	C22	15	R	C200	POS	1604	PLUTO	608	20	2	8193
500008	05	C01	15	R	C200	POS	1604	PLUTO	608	20	2	8193
500009	28	D44	15	R	C200	POS	1604	PLUTO	608	20	2	8193
500010	21	D22	15	R	C200	POS	1604	PLUTO	608	20	2	8193
500011	07	D01	15	R	C200	POS	1604	PLUTO	608	20	2	8193
500100	31	A44	13	R	C201	NEG	1604	PLUTO	608	20	6	8193
500101	25	A18	13	R	C201	NEG	1604	PLUTO	608	20	6	8193
500102	15	A01	13	R	C201	NEG	1604	PLUTO	608	20	6	8193
500103	28	B44	13	R	C201	NEG	1604	PLUTO	608	20	6	8193
500104	25	B12	13	R	C201	NEG	1604	PLUTO	608	20	6	8193
500105	12	B01	13	R	C201	NEG	1604	PLUTO	608	20	6	8193
500106	22	C44	13	R	C201	NEG	1604	PLUTO	608	20	6	8193
500107	18	C22	13	R	C201	NEG	1604	PLUTO	608	20	6	8193
500108	07	C01	13	R	C201	NEG	1604	PLUTO	608	20	6	8193
500109	22	D44	13	R	C201	NEG	1604	PLUTO	608	20	6	8193
500110	15	D22	13	R	C201	NEG	1604	PLUTO	608	20	6	8193
500111	05	D01	13	R	C201	NEG	1604	PLUTO	608	20	6	8193

MAIN HARNESS ASSEMBLY



CONTROL DATA		VALLEY FORGE DIVISION NORRISTOWN, PA.			TITLE WIRE LISTING						WL	DOCUMENT NO. 49422000	REV. J
SHEET 2 OF													
CONDUCTOR IDENT.	FIND NO.	GAUGE (REF.)	COLOR (REF.)	LENGTH (APPROX)	ORIGIN		ACCESS. FIND NO.	DESTINATION		ACCESS. FIND NO.	REMARKS		
A 1	28	20	4	80	J204	A	8	J1105	3	16			
A 2	28	20	4	80		B	8	J1105	4	16			
A 3	38	24	4	60		C	7	J400	C	7			
A 4						D			D				
A 5						E			E				
A 6						F			F				
A 7						H			H				
A 8						J			J				
A 9						K			K				
A 10						L			L				
A 11	38	24	4			M	7		M	7			
A 12	29	20	0			N	8		N	8			
A 13	38	24	4			P	7		MM	7			
A 14						R			P	7			
A 15						S		J400	R	7			
A 16						U		P2	P	2			
A 17						V		P2	R	2			
A 18						W		P2	V	2			
A 19	38	24	4	60	J204	X	7	S1110	NO	20			

CONTROL DATA		VALLEY FORGE DIVISION NORRISTOWN, PA.			TITLE WIRE LISTING						WL	DOCUMENT NO. 49422000	REV. K
SHEET 3 OF													
CONDUCTOR IDENT.	FIND NO.	GAUGE (REF.)	COLOR (REF.)	LENGTH (APPROX)	ORIGIN		ACCESS. FIND NO.	DESTINATION		ACCESS. FIND NO.	REMARKS		
A 20	28	20	4	60	J204	Y	8	P2	AA	3	SPARE		
A 21	38	24	4	60	J204	1A	7	J400	Y	7			
A 22	38	24	4	60		1B	7	J400	BB	7			
A 23B	43	20	2	60		1C	8	J1100	1	16			
A 24B			0			1D	8	J1100	2	16			
A 25		SHIELD				1E	8	J1100	3	16			
A 26	38	24	4	60		1G	7	J400	Z	7			
A 27	38	24	4	60		1H	7	J400	DD	7			
A 28C	43	20	2	60		1I	8	J1100	7	16			
A 29C			0			1J	8	J1100	8	16			
A 30		SHIELD			J204	1K	8	J1100	9	16			
31													
32													
A 33													
A 34	28	20	4	50	J204	1Q	8	S1311	NO	19			
A 35				50		1R		J1102	6	16			
A 36				50		1S		J1102	2				
A 37				66		1T		J1101	6				
A 38	28	20	4	66	J204	1U	8	J1101	2	16			

CONTROL DATA		VALLEY FORGE DIVISION		TITLE		WIRE LISTING		WL		DOCUMENT NO.	REV.
		NORRISTOWN, PA.								49422000	K
										SHEET 4 OF	
CONDUCTOR IDENT.	FIND NO.	GAUGE (REF.)	COLOR (REF.)	LENGTH (APPROX)	ORIGIN		ACCESS. FIND NO.	DESTINATION		ACCESS. FIND NO.	REMARKS
A 39	28	20	4	66	J204	1V	8	S1304	NO	19	
A 40	28	20	4	52	J204	1W	8	S1301	NO	19	
A 41	28	20	4	80	J204	1X	8	S1303	NO	19	
A 42	28	20	4	92	J204	1Y	8	S1306	NO	19	
A 43	35	16	2	60	J204	1Z	9	P2	L	4	
A 44	28	20	4	60	J204	AA	8	J1108	6	16	
A 45	28	20	4	60	J204	AB	8	J1108	2	16	
46											
A 47	38	24	4	60	J204	AD	7	P2	W	2	
48											
A 49	34	16	6	60	J204	AE	9	P2	N	4	
A 50	34	16	6			AH	9	P2	K	4	
A 51	35	16	2			AJ	9	P2	M	4	
A 52	38	24	4			AK	7	J400	JJ	7	
A 53	38	24	4			AL	7		FF	7	
A 54	28	20	4			BD	8		AA	8	SPARE
A 55	38	24	4			BA	7		HH	7	
A 56	38	24	4			T	7		S	7	
A 57	38	24	4	60	J204	AW	7	J400	LL	7	

CONTROL DATA		VALLEY FORGE DIVISION		TITLE		WIRE LISTING		WL		DOCUMENT NO.	REV.
		NORRISTOWN, PA.								49422000	J
										SHEET 5 OF	
CONDUCTOR IDENT.	FIND NO.	GAUGE (REF.)	COLOR (REF.)	LENGTH (APPROX)	ORIGIN		ACCESS. FIND NO.	DESTINATION		ACCESS. FIND NO.	REMARKS
58											
59											
60											
61											
62											
A 63	38	24	4	60	J204	BK	7	J400	T	7	
A 64						BL			U		
A 65						BM			V		
A 66						BN			W		
A 67	38	24	4	60	J204	BP	7	J400	X	7	
68											
69											
70											
71											
A 72	38	24	4	60	J204	CP	7	J400	KK	7	
A 73	38	24	4	60	J204	CN	7	J400	EE	7	
A 74	44				E200			E00			
A 75	28	20	4	52	P2	A	3	S1302	NO	19-22	7
A 76	28	20	4	68	P2	B	3	S1303	NO	19	

CONTROL DATA	VALLEY FORGE DIVISION NORRISTOWN, PA.	TITLE	WIRE LISTING	WL	DOCUMENT NO.	REV.
					49422000	K
SHEET 6 OF						

CONDUCTOR IDENT.	FIND NO.	GAUGE (REF.)	COLOR (REF.)	LENGTH (APPROX)	ORIGIN		ACCESS. FIND NO.	DESTINATION		ACCESS. FIND NO.	REMARKS
A 77	28	20	4	48	P2	C	3	S1301	NO	19	
A 78	28	20	4	68	P2	D	3	S1304	NO	19	
A 79	28	20	4	88	P2	E	3	S1306	NO	19	
A 80	28	20	4	72	P2	F	3	S1305	NO	19-22	△7
A 81	30	20	6	75	P2	H	3	J1105	L	15	
A 82	30	20	6	76	P2	J	3	J100	A	8	
A 83	28	20	4	50	P2	S	3	J100	4	16	
A 84	33	16	0	60	P2	T	4	TB1000		18	
A 85	38	24	4	60	P2	U	2	J100	B	7	
A 86	33	16	0	60	P2	X	4	TB1000		18	
A 87	38	24	4	60	P2	Y	2	J100	NN	7	
A 88	28	20	4	50	P2	1F	3	L1109	B	15-22	△7
A 89	30	20	6	30	P2	1D	3	L1109	T	15-22	△7
A 90	28	20	4	76	P2	1M	3	J400	CC	8	SPARE
91											
92											
B 93	28	20	4	70	P2	AX	3	S1124	T	17-21	△7
B 94	28	20	4	70	P2	AY	3	S1124	B	17-21	△7
B 95	28	20	4	85	P2	AZ	3	S1123	T	17-21	△7

CONTROL DATA	VALLEY FORGE DIVISION NORRISTOWN, PA.	TITLE	WIRE LISTING	WL	DOCUMENT NO.	REV.
					49422000	K
SHEET 7 OF						

CONDUCTOR IDENT.	FIND NO.	GAUGE (REF.)	COLOR (REF.)	LENGTH (APPROX)	ORIGIN		ACCESS. FIND NO.	DESTINATION		ACCESS. FIND NO.	REMARKS
B 96	28	20	4	85	P2	BA	3	S1123	B	17-21	△7
97											
98											
B 99	28	20	4	82	P2	BD	3	J1101	4	16	
B100	28	20	4	80	P2	BE	3	J1102	4	16	
B101	28	20	4	80	P2	BF	3	J1108	4	16	
A102											
B103M	41	16	3	68		BH	4	J507	5	13	
B104M			2			BJ		J507	4	13	
B105M			0			BN		J507	3	13	
B106N	40	16	9	50		BK		J1003	T	18-27	
B107N			0			BL		J1003	B	18-27	
B108P	41	16	3	67		BM		J506	3	13	
B109P			2			BS			2		
B110P			0			BZ			1		
B111P	40	16	0	67		BT			6		
B112R			9			BX		J506	5	13	
B113S	42	16	9	85		BY		J1107	1	15	
B114S			4		P2	BW	4	J1107	3	15	

CONTROL DATA	VALLEY FORGE DIVISION NORRISTOWN, PA.	TITLE		WL	DOCUMENT NO.	REV.
		WIRE LISTING			49422000	K
SHEET 8 OF						

CONDUCTOR IDENT.	FIND NO.	GAUGE (REF.)	COLOR (REF.)	LENGTH (APPROX)	ORIGIN		ACCESS. FIND NO.	DESTINATION		ACCESS. FIND NO.	REMARKS
B115S			0		P2	CC	4	J1107	2	15	
B116T	41	16	3	72	P2	BU	4	J1106	4	15	
B117T			2		P2	BP	4	J1106	6	15	
B118T			0		P2	CA	4	J1106	2	15	
119											
120											
B121U	41	16	3	66	P2	BR	4	J505	3	13	
B122U			2		P2	BV	4	J505	2	13	
B123U			0		P2	CB	4	J505	1	13	
124											
B125	32	16	4	75	P2	CD	4	J1104	6	15	
B126	32	16	4	75	P2	CE	4	J1104	1	15	
B127	32	16	4	87		CF	4	J1103	1	15	
B128	32	16	4	87		CH	4	J1103	6	15	
B129	28	20	4	81		CJ	3	L1114	T	19	
B130	28	20	4	81		CK	3	L1114	B	19/48	
B131	28	20	4	92		CR	3	L1113	T	19/48	
B132	28	20	4	92		CS	3	L1113	B	19	
B133	35	16	2	75	P2	CL	4	J1104	5	15	

CONTROL DATA	VALLEY FORGE DIVISION NORRISTOWN, PA.	TITLE		WL	DOCUMENT NO.	REV.
		WIRE LISTING			49422000	K
SHEET 9 OF 9						

CONDUCTOR IDENT.	FIND NO.	GAUGE (REF.)	COLOR (REF.)	LENGTH (APPROX)	ORIGIN		ACCESS. FIND NO.	DESTINATION		ACCESS. FIND NO.	REMARKS
B134	33	16	0	75	P2	CM	4	J1104	2	15	
B135	33	16	0	87	P2	CN	4	J1103	2	15	
B136	34	16	6	87	P2	CP	4	J1103	5	15	
137											
138											
139											
140											
A141	28	20	4	30	S1311	C	19	S1312	NO	19	
A142	29	20	0	30	TB1000		20	S1312	C		
A143				12				S1301	C		
A144				36				S1303	C		
A145				30				S1304	C		
A146				52				S1306	C	19	
A147				15				S1302	C	19-22	7
A148				30				S1305	C	19-22	7
A149				30				J1100	6	16	
A150				20				S1110	C	20	
A151	29	20	0	30	TB1000		20	J1105	5	16	
152											

POWER SUPPLY HARNESS



DWN	L. PINCHBE	11-4-70	TITLE	VALLEY FORGE DIVISION	WIRE LIST POWER SUPPLY HARNESS	PREFIX	DOCUMENT NO.	REV
CHKD	D. McNamee	11-4-70				WL	49889800	B
ENG								
MEG								
APPR			FIRST USED ON					
Q.A.	R. Z. Moore	11-4-70	CODE IDENT	05875	PLUTO TRANSPORT		SHEET	1 of 10

SHEET REVISION STATUS										REVISION RECORD					
10	9	8	7	6	5	4	3	2	1	REV	ECO	DESCRIPTION	DRFT	DATE	APP
A	A	A	A	A	A	A	A	A	A	A	PB7920	RELEASED	L.P.	11-4-70	R.L.L.
B	B	B	B	B	B	B	B	B	B	B	PB8343	ADDED NOTE 5, CHNGD SHT2-10	PMD	3/8-71	ES

NOTES: 1. DETACHED LISTS
A. PL 49419001.
2. FOR MECH ASSY SEE 49419001.
3. RING TERMINAL TO BE TERMINATED ON MTG SCREW OF GND BLOCK ASSY.

4. AUXILIARY LETTER DESIGNATION IN CONDUCTOR IDENTIFICATION COLUMN INDICATES SEPARATE WIRE GROUPING FOR HARNESS.

 GROUND TERMINATES AT GND BLK ASSY.

DETACHED LISTS

VALLEY FORGE DIVISION NORRISTOWN, PA.	TITLE	WIRE LISTING	WL	DOCUMENT NO.	49889800	REV.	B
			SHEET 2 OF				

CONDUCTOR IDENT.	FIND NO.	GAUGE (REF.)	COLOR (REF.)	LENGTH (APPROX)	ORIGIN		ACCESS. FIND NO.	DESTINATION		ACCESS. FIND NO.	REMARKS
1 A	21	20	4		J2	A	6	LP1051	3	28	
2 A	21					B	6	LP1051	1		
3 A	21					C	6	LP1051	6		
4 A	21					D	6	RP1051	6		
5 A	21					E	6	RP1051	1		
6 A	21	20	4			F	6	RP1051	3	28	
7 A	17	24	6			H	7	TB2	-20	9	
8 A	19	16	6			J	5	TB2	-20	8	
9 A	19	16	6			K	5	TB2	-20	8	
10 A	25	16	2			L	5	TB2	+20	8	
11 A	25	16	2			M	5	TB2	+20	8	
12 A	19	16	6			N	5	TB2	-20	8	
13 A	20	24	4			P	7	TB1	27	9.47	
14 A	20	24	4			R	7	TB1	28	9.47	
15 A	21	20	4			S	6	T2	3	29	
16 A	15	16	0			T	5	GND	8		
17 A	20	24	4			U	7	TB1	5	9.47	
18 A	20	24	4			V	7	TB1	29	9.47	
19 A	20	24	4		J2	W	7	TB1	24	9.47	

CONTROL DATA		VALLEY FORGE DIVISION		TITLE		WL		DOCUMENT NO.		REV.
		NORRISTOWN, PA.		WIRE LISTING				49889800		B
SHEET 3 OF										

CONDUCTOR IDENT.	FIND NO.	GAUGE (REF.)	COLOR (REF.)	LENGTH (APPROX)	ORIGIN		ACCESS. FIND NO.	DESTINATION		ACCESS. FIND NO.	REMARKS
20 A	15	16	0		J2	X	5		GND	8	△
21 A	20	24	4		J2	Y	7	TB1	4	9.47	
22 B	20	24	4		TB1	4	9.47	CB1	3D	29	
23 A	20	24	4		TB1	2	9.47	K2	L2	14	
24 A	20	24	4		TB1	1	9.47	T3	3	29	
25 A	20	24	4		TB1	3	9.47	T3	5	29	
26 A	4	24	0		T3	4	29		GND	9	△
27 A	20	24	4		TB1	24	9.47	K2	4B	14	
28 A	24	20	2		TB1	9	9.47	TB2	+20	9	
29 A	18	20	6		TB1	25	9.47	TB2	-20	9	
30 A	15	16	0		TB1	38	8.47		GND	8	△
31 A	20	24	4		TB1	8	9.47	K2	4A	14	
32 A	15	16	0		K2	4C	45		GND	8	△
33 A	21	20	4		TB2	NEU	9	T3	1	29	
34 B	21	20	4		FL3	R	13	T3	2	29	
35 A	17	24	6		K1002	L2	14	TB2	-20	9	
36 A	17	24	6		K1001	L2	14	TB2	-20	9	
37 A	17	24	6		K1	L2	14	TB2	-20	9	
38 A	20	24	4		K1	L1	14	TB1	27	9.47	

CONTROL DATA		VALLEY FORGE DIVISION		TITLE		WL		DOCUMENT NO.		REV.
		NORRISTOWN, PA.		WIRE LISTING				49889800		B
SHEET 4 OF										

CONDUCTOR IDENT.	FIND NO.	GAUGE (REF.)	COLOR (REF.)	LENGTH (APPROX)	ORIGIN		ACCESS. FIND NO.	DESTINATION		ACCESS. FIND NO.	REMARKS
39 A	20	24	4		K1002	L1	14	TB1	28	9.47	
40 A	20	24	4		K1001	L1	14	TB1	29	9.47	
41 A	22	16	4		TB1	7	8.47	J3	2	31	
42 A	22	16	4		TB1	7	8.47	R3	B	29	
43 A	39	12	6		C2	NEG	12 B	CB4	T	12	
44 A	39	12	2		C4	POS	12	CB5	T	12	
45 A	38	12	6		CB4	B	12	TB2	-20	35	
46 A	39	12	2		CB5	B	12	TB2	+20	35	
47 A	15	16	0		TP	GND	29		GND	8	△
48 A	20	24	4		CB4	5B	14	K2	L1	14	
49 A	20	24	4		CB4	3D	14	CB5	5B	14	
50 A	21	20	4		J3	3	41	T2	1	29	
51 A	21	20	4		J3	4	41	T2	2	29	
52 A	16	20	0		T2	4	29		GND	9	△
53 A	19	16	6		TP	-20	29	TB2	-20	8	
54 A	25	16	2		TP	+20	29	TB2	+20	8	
55 A	43				FL3	GND FRAME			GND		△
56 B	21	20	4		J2	CS	6	K1002	2B	13	
57 B	21	20	4		J2	CR	6	K1001	C	29	

CONTROL DATA		VALLEY FORGE DIVISION NORRISTOWN, PA.		TITLE WIRE LISTING							WL		DOCUMENT NO. 49889800	REV. B
SHEET 5 OF														
CONDUCTOR IDENT.	FIND NO.	GAUGE (REF.)	COLOR (REF.)	LENGTH (APPROX)	ORIGIN		ACCESS. FIND NO.	DESTINATION		ACCESS. FIND NO.	REMARKS			
58 B	19	16	6		J2	CP	5	TB2	-20	8				
59 B	15	16	0		↑	CN	5		GND	8	△	S		
60 B	15	16	0			CM	5		GND	8	△	S		
61 B	25	16	2			CL	5	TB2	+20	8				
62 B	21	20	4			CK	6	R1002	C	29				
63 B	21	20	4			CJ	6	K1002	1B	13				
64 B	22	16	4			CH	5	K1002	3A	45				
65 B	22	16	4			CF	5	LJ1050	9	27				
66 B	22	16	4			CE	5	RJ1050	9	27				
67 B	22	16	4			CD	5	K1002	3A	45				
68 B	21	20	4			CC	6	TB1	17	9, 47				
69 B	22	16	4			CB	5	CB1	AB	45				
70 B	22	16	4			CA	5	CB1001	AB					
71 B	22	16	4			CZ	5	CB3	AB	45				
72 B	22	16	4			BX	5	TB2	NEUT	8				
73 B	21	20	4			BY	6	TB2	NEUT	9				
74 B	21	20	4			BW	6	C1006	POS	10				
75 B	22	16	4			BV	5	CB1	BB	45				
76 B	22	16	4		J2	BV	5	CB1001	CB					

CONTROL DATA		VALLEY FORGE DIVISION NORRISTOWN, PA.		TITLE WIRE LISTING							WL		DOCUMENT NO. 49889800	REV. B
SHEET 6 OF														
CONDUCTOR IDENT.	FIND NO.	GAUGE (REF.)	COLOR (REF.)	LENGTH (APPROX)	ORIGIN		ACCESS. FIND NO.	DESTINATION		ACCESS. FIND NO.	REMARKS			
77 B	22	16	4		J2	BT	5	R2	T	29				
78 B	22	16	4		↑	BS	5	CB3	BB	45				
79 B	22	16	4			BR	5	CB1	CB	45				
80 B	22	16	4			BP	5	CB1001	BB	45				
81 B	22	16	4			BN	5	CB3	AB	45				
82 B	22	16	4			BM	5	CB3	CB	45				
83 B	22	16	4			BL	5	CB3	AT	45				
84 B	22	16	4			BK	5	TB2	NEUT	8				
85 B	22	16	4			BJ	5	CB3	BB	45				
86 B	22	16	4			BH	5	CB3	CB	45				
87 B	21	20	4			BF	6	R1011	B	29				
88 B	21	20	4		↓	BE	6	R1007	B	29				
89 B	21	20	4		J2	BD	6	R1006	B	29				
90 B	21	20	4		RP1051	S	28	K1002	1B	13				
91 B	21	20	4		LP1051	8	28	K1002	2B	13				
92 B	16	20	0		LP1051	9	28		GND	9	△	S		
93 B	21	20	4		LP1051	7	28	K1002	4A	13				
94 B	21	20	4		LP1051	5	28	K1001	4B	13				
95 B	21	20	4		RP1051	4	28	K1001	2B	13				

CONTROL DATA		VALLEY FORGE DIVISION		TITLE		WL		DOCUMENT NO.		REV.	
		NORRISTOWN, PA.		WIRE LISTING				49889800		B	
SHEET 7 OF											
CONDUCTOR IDENT.	FIND NO.	GAUGE (REF.)	COLOR (REF.)	LENGTH (APPROX)	ORIGIN		ACCESS. FIND NO.	DESTINATION		ACCESS. FIND NO.	REMARKS
96 B	16	20	0		K1002	1C	13		GND	9	△
97 B	22	16	4		RJ1050	7	27	R1008	T	29	
98 B	22	16	4		RJ1050	3	27	R1010	T	29	
99 B	22	16	4		RJ1050	1	27	R1009	T	29	
100 B	22	16	4		LJ1050	1	27	R1004	T	29	
101 B	22	16	4		LJ1050	3	27	R1005	T	29	
102 B	22	16	4		LJ1050	7	27	R1003	T	29	
103 B	16	20	0		K1002	2C	13		GND	9	△
104 B	21	20	4		LP1051	4	28	K1001	3B	13	
105 B	21	20	4		RP1051	5	28	K1001	4B	13	
106 B	21	20	4		RP1051	7	28	K1002	4A	13	
107 B	16	20	0		RP1051	9	28		GND	9	△
108 B	16	20	0		K1001	4C	13		GND	9	△
109 B	18	20	6		K1002	4C	13	TB2	-20	9	
110 B	21	20	4		R1002	R	29	K1001	2B	13	
111 B	21	20	4		R1001	R	29	K1001	3B	13	
112 B	22	16	4		R1004	B	29	K2	2A	45	
113 B	22	16	4		R1005	B	29	K2	3A	45	
114 B	22	16	4		R1003	B	29	K2	1A	45	

CONTROL DATA		VALLEY FORGE DIVISION		TITLE		WL		DOCUMENT NO.		REV.	
		NORRISTOWN, PA.		WIRE LISTING				49889800		B	
SHEET 8 OF											
CONDUCTOR IDENT.	FIND NO.	GAUGE (REF.)	COLOR (REF.)	LENGTH (APPROX)	ORIGIN		ACCESS. FIND NO.	DESTINATION		ACCESS. FIND NO.	REMARKS
115 B	22	16	4		R1009	B	29	K2	2A	45	
116 B	22	16			R1010	B	29	K2	3A	45	
117 B	22	16			R1008	B	29	K2	1A	45	
118 B	23	12			CB2	AB	12	FL1	L	12	
119 B	22	16			CB3	AT	45	CB1001	AT	45	
120 B	23	12			K1	1A	12	CB3	AT	12	
121 B	23	12			CB2	BB	12	FL2	L	12	
122 B	22	16			CB3	BT	45	CB1001	BT	45	
123 B	23	12			K1	2A	12	CB3	BT	12	
124 B	23	12			CB2	CB	12	FL3	L	12	
125 B	22	16			CB3	CT	45	CB1001	CT	45	
126 B	23	12			K1	3A	12	CB3	CT	12	
127 B	22	16			K1002	3C	45	TB2	NEUT	8	
128 B	22	16			K2	1A	45	CB1	AT	45	
129 B	22	16			K2	2A	45	CB1	BT	45	
130 B	22	16			K2	2C	45	J3	1	31	
131 B	22	16			TRX63	RT	46	R1005	B	29	
132 B	22	16			K2	3A	45	TB1	6	8, 47	
133 B	22	16	4		TB1	6	8, 47	CB1	CT	45	

VALLEY FORGE DIVISION NORRISTOWN, PA.				TITLE WIRE LISTING							WL		DOCUMENT NO. 49889800	REV. B
SHEET 9 OF														
CONDUCTOR IDENT.	FIND NO.	GAUGE (REF.)	COLOR (REF.)	LENGTH (APPROX)	ORIGIN		ACCESS. FIND NO.	DESTINATION		ACCESS. FIND NO.	REMARKS			
134 B	22	16	4		R5	CW	44	CB3	AB	45				
135 B	22	16			R5	C	44	R2	B	29				
136 B	22	16			TRX61	LT	46	R1003	B	29				
137 B	22	16			TRX62	RB	46	R1004	F	29				
138 B	23	12			FL1	R	12	K2	1C	12				
139 B	23	12			FL2	R	12	K2	2C	12				
140 B	23	12			FL3	R	12	K2	3C	12				
141 B	22	16			CB1001	BF	45	K1001	1C	45				
142 B	22	16			K1001	1C	13	TB1	32	8.47				
143 B	20	24	4		K1001	1A	14	TB1	16	9.47				
144 B	24	20	2		R1007	T	29	TB2	+20	9				
145 B	24	20	2		R1011	T	29	TB2	+20	9				
146 B	24	20	2		R1006	T	29	TB2	+20	9				
147 B	21	20	4		TB1	11	9.47	K1001	2C	13				
148 B	21	20	4		TB1	11	9.47	K1001	3C	13				
149 B	21	20	4		TB1	10	9.47	C1007	NEUT	13				
150 B	18	20	6		K1	4C	13	TB2	-20	9				
151 B	16	20	0		C1007	POS	13		CM	9			5	
152 B	21	16	4		K2	T	29	CB1	CT	45				

VALLEY FORGE DIVISION NORRISTOWN, PA.				TITLE WIRE LISTING							WL		DOCUMENT NO. 49889800	REV. B
SHEET 10 OF 10														
CONDUCTOR IDENT.	FIND NO.	GAUGE (REF.)	COLOR (REF.)	LENGTH (APPROX)	ORIGIN		ACCESS. FIND NO.	DESTINATION		ACCESS. FIND NO.	REMARKS			
153 B	21	20	4		K1	4A	13	TB1	12	9.47				
154 B	21	20	4		C1006	NEUT	10	TB2	NEUT	9				
155 B	21	20	4		DS1	L	9	FL3	R	13				
156 B	21	20	4		DS1	R	9	TB2	NEUT	9				
157 B	22	16	4		TRX61	RC	46	K1	1A	45				
158 B	22	16	4		TRX62	1C	46	K1	2A	45				
159 B	22	16	4		TRX63	1C	46	K1	3A	45				
160 B	22	16	4		TRX61	LR	46	K1	1C	45				
161 B	22	16	4		TRX62	RT	46	K1	2C	45				
162 B	22	16	4		TRX62	RB	46	K1	3C	45				
163 B	23	12	4		FL6	R	12	TB2	NEUT	35				
164 B	20	24	4		CB1	5B	29	CB5	3D	29				
165 B	21	20	4		LJ1050	8	27	TB2	NEUT	8				
166 B	21	20	4		RJ1050	8	27	TB2	NEUT	8				

DC PANEL HARNESS



MINNEAPOLIS, MINNESOTA		TITLE WIRE LIST - HARNESS ASSEMBLY (DC PANEL)	WL	DOCUMENT NO. 45741300	REV. B
		PRODUCT PLUTO TRANSPORT	SHEET 1 OF 2		

REVISION STATUS OF SHEETS				REVISIONS						
1	2			REV.	ECO	DESCRIPTION	DRFT	DATE	CHKD	APPR
A	A			A		RELEASED				
B	B			B	PE8119	SEE CO	W.L.	6-15-67		

NOTES:
 1. DETACHED LISTS:
 A. PL 457412CO
 2. FOR MECH. ASSY SEE
 DWG NO. 45741200.

MINNEAPOLIS, MINNESOTA		TITLE WIRE LISTING	WL	DOCUMENT NO. 45741300	REV. B
			SHEET 2 OF 2		

CONDUCTOR IDENT.	FIND NO.	GAUGE (REF.)	COLOR (REF.)	LENGTH (APPROX)	ORIGIN		ACCESS. FIND NO.	DESTINATION		ACCESS. FIND NO.	REMARKS
1	4	16	4		J3	1	6	FL4T	R	2	
2	4	16			J3	2	6	FL5B	R	2	
3	4	16			J3	3	6	T1	7	2	
4	4	16			J3	4	6	T1	5	2	
5	5	12			C3	POS	3	CR2	LB	3	
6	5	12			CR1	RB		C1	NEG		
7	5	12			CR1	RT		CR2	LB		
8	5	12			CR2	LT		CR1	RB		
9	5	12			CR1	L		T1	7		
10	5	12			FL4T	L		T1	1		
11	5	12			FL5B	L		T1	2		
12	5	12	4		CR2	R	3	T1	5	3	

COMMENT SHEET

MANUAL TITLE CONTROL DATA-BE102 608 MAGNETIC TAPE TRANSPORT
Customer Engineering Manual

PUBLICATION NO. 40860800 REVISION J

FROM: NAME: _____
BUSINESS
ADDRESS: _____

COMMENTS:

This form is not intended to be used as an order blank. Your evaluation of this manual will be welcomed by Control Data Corporation. Any errors, suggested additions or deletions, or general comments may be made below. Please include page number references and fill in publication revision level as shown by the last entry on the Record of Revision page at the front of the manual. Customer engineers are urged to use the TAR.

CUT ALONG LINE

FORM CA231 REV. 1-67

NO POSTAGE STAMP NECESSARY IF MAILED IN U. S. A.

FOLD ON DOTTED LINES AND STAPLE

FOLD

FOLD

FIRST CLASS
PERMIT NO. 876
NORRISTOWN, PENNA.

BUSINESS REPLY MAIL
NO POSTAGE STAMP NECESSARY IF MAILED IN U.S.A.

POSTAGE WILL BE PAID BY
CONTROL DATA CORPORATION
2621 VAN BUREN AVENUE
NORRISTOWN, PENNSYLVANIA 19401

ATTN:TECHNICAL PUBLICATIONS DEPT.

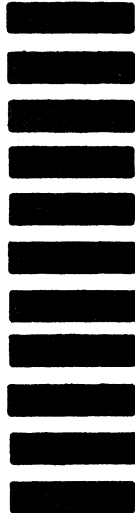

CUT ALONG LINE

FOLD

FOLD